

LED Driver with Average-Mode Constant Current Control

General Description

The FP7127 is an average current mode control LED driver IC operating in a constant off-time mode. FP7127 does not produce a peak-to-average error, and therefore greatly improves accuracy, line and load regulation of the LED current without any need for loop compensation or high-side current sensing. The output LED current accuracy is $\pm 2\%$.

PWM dimming input is provided that accepts an external control TTL compatible signal. The output current can be programmed by an internal 250mV reference.

Features

- Fast Average Current Control
- Low-side adjustable current sense
- PWM dimming
- Thermal shutdown
- Short circuit protection
- Under voltage lockout
- Requires Few External Components for Operation
- Internal 100V/300mΩ N-MOSFET

Applications

- DC/DC LED driver applications
- LED Street Lighting
- Automotive
- Desk lights and room lighting
- MR16 LED spotlight
- LED backlighting
- Constant-current regulators

Typical Application Circuit

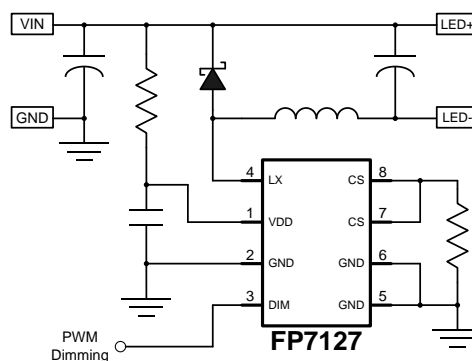

This datasheet contains new product information. Advanced Analog Technology reserves the rights to modify the product specification without notice. No liability is assumed as a result of the use of this product. No rights under any patent accompany the sales of the product.

LED Driver with Average-Mode Constant Current Control

Function Block Diagram

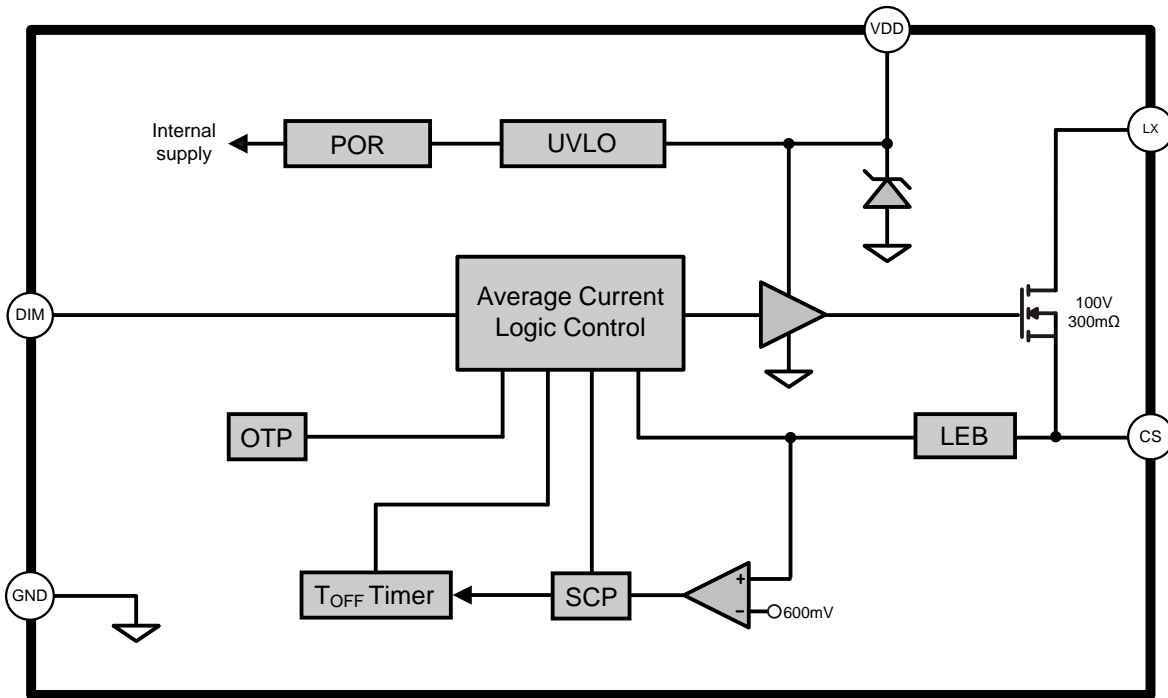

Pin Descriptions

SOP-8L(EP)

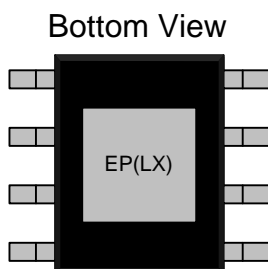
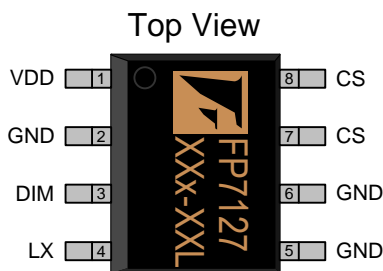

Name	No.	I / O	Description
VDD	1	P	This is the power supply pin for all internal circuits.
GND	2	P	Ground return for all internal circuitry.
DIM	3	I	This pin is the linear & PWM dimming input of the IC.
LX	4	I	Power switch
GND	5	P	Ground return for all internal circuitry. Must be connected to pin 2.
GND	6	P	Ground return for all internal circuitry. Must be connected to pin 2.
CS	7	O	This pin is the current sense pin.
CS	8	O	This pin is the current sense pin.
EP(LX)	9	I	Power switch

This datasheet contains new product information. Advanced Analog Technology reserves the rights to modify the product specification without notice. No liability is assumed as a result of the use of this product. No rights under any patent accompany the sales of the product.

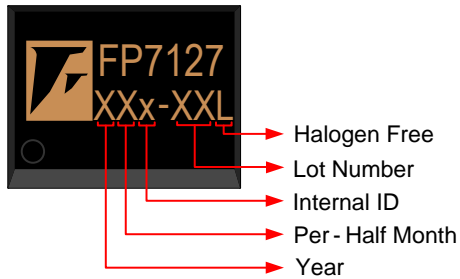
LED Driver with Average-Mode Constant Current Control**Marking Information**

Halogen Free: Halogen free product indicator

Lot Number: Wafer lot number's code

Internal ID: Internal Identification Code

Per-Half Month: Production period indicator in half month time unit

For Example : A → First Half Month of January

B → Second Half Month of January

C → First Half Month of February

D → Second Half Month of February

Year: Production year's last digit

Ordering Information

Part Number	Ambient Operating Temperature	Junction Operating Temperature	Package	MOQ	Description
FP7127XR-G1	-25°C ~ +85°C	-25°C ~ +125°C	SOP-8L(EP)	2500 EA	Tape & Reel

Absolute Maximum Ratings

Parameter	Symbol	Conditions	Min.	Typ.	Max.	Unit
Power Supply Voltage	V_{DD}	V_{DD} to GND	-0.3		16	V
CS, DIM			-0.3		5.5	V
Internal MOS V_{DS} Breakdown Voltage	V_{LX}		100			V
Allowable Power Dissipation	P_D	SOP-8L(EP) $T_A \leq +25^\circ\text{C}$			1500	mW
Junction to Ambient Thermal Resistance	θ_{JA}				60	$^\circ\text{C} / \text{W}$
Operating Temperature			-25		+85	$^\circ\text{C}$
Storage Temperature	T_S	SOP-8L(EP)	-40		+150	$^\circ\text{C}$
SOP-8L Lead Temperature		(soldering, 10 sec)			+260	$^\circ\text{C}$

IR Re-flow Soldering Curve

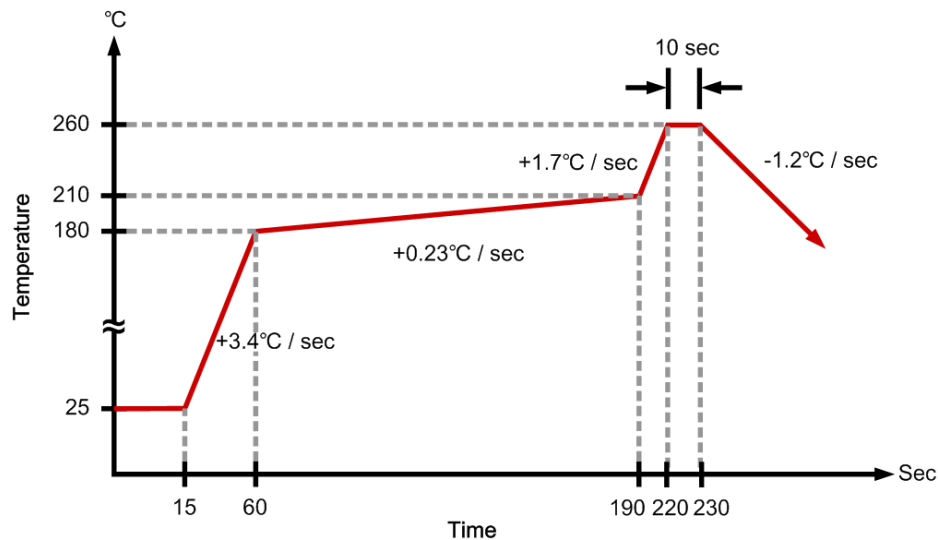

This datasheet contains new product information. Advanced Analog Technology reserves the rights to modify the product specification without notice. No liability is assumed as a result of the use of this product. No rights under any patent accompany the sales of the product.

Rev. 0.61

Recommended Operating Conditions

Parameter	Symbol	Conditions	Min.	Typ.	Max.	Unit
Supply Voltage	VDD		8		12	V
Ambient Operating Temperature			-25		+85	°C
Junction Operating Temperature			-25		+125	°C

DC Electrical Characteristics (VDD=12V, T_A = 25°C, unless otherwise noted)

Parameter	Symbol	Conditions	Min.	Typ.	Max.	Unit
Power supply						
VDD clamp voltage	V _{DD(clamp)}	I _{IN(clamp)} =2mA	11	12.8	14	V
Operation current	I _{IN(operation)}	VDD=11V、V _{CS} =0V、DIM=5V		0.5		mA
VDD under voltage lockout threshold	UVLO	VDD rising		11.1		V
VDD under voltage lockout hysteresis	Δ UVLO			3.7		V
PWM Dimming						
Pin DIM input low voltage	V _{EN(lo)}	VDD = 12V			0.75	V
Pin DIM input high voltage	V _{EN(hi)}	VDD = 12V	2.5			V
Average Current Sense Logic						
Current sense reference voltage	V _{CS}		245	250	255	mV
Minimum on-time	T _{ON(min)}	CS=V _{CS} + 30mV		0.5		us
Minimum off-time	T _{OFF(min)}	CS=0V		0.5		us
Short Circuit Protection						
Hiccup threshold voltage	V _{CS}			600		mV
Short circuit hiccup time	T _{HICCUP}			1.2		ms
Minimum on-time (short circuit)	T _{ON(min)}	CS=5V			200	ns
Internal MOSFET						
Drain-Source Breakdown Voltage	BV _{DSS}	V _{GS} =0V, I _D =250uA	100			V
Drain-Source Leakage Current	I _{DSS}	V _{DS} =80V, V _{GS} =0V, T _J =25°C			1	uA
Static Drain-Source On-Resistance ²	R _{DS(ON)}	I _D =1A			300	mΩ
Thermal Protection						
Thermal shutdown	OTP	VDD=12V		160		°C

Function Description

Input Voltage Regulator

The FP7127 can be powered directly from its VDD pin and can work from 8 - 12V DC at its VDD pin. This voltage is used to power the IC and any external resistor dividers needed to control the IC. The VDD pin must be bypassed by a low ESR capacitor to provide a low impedance path for the high frequency current of the internal driver. The recommended input resistor value is summarized below:

Input Voltage	Input Resistor	VDD Capacitors
12V	100Ω	10uF
24V	2kΩ	10uF
48V	6kΩ	10uF
72V	10 kΩ	10uF
85V	14 kΩ	10uF

Average Current Control

The LED current is detected using a sense resistor at the CS pin. The feedback operates in a fast open-loop mode. No compensation is required., output current is programmed simply as:

$$I_{LED}(A) = \frac{0.25V}{R_{CS}(\Omega)}$$

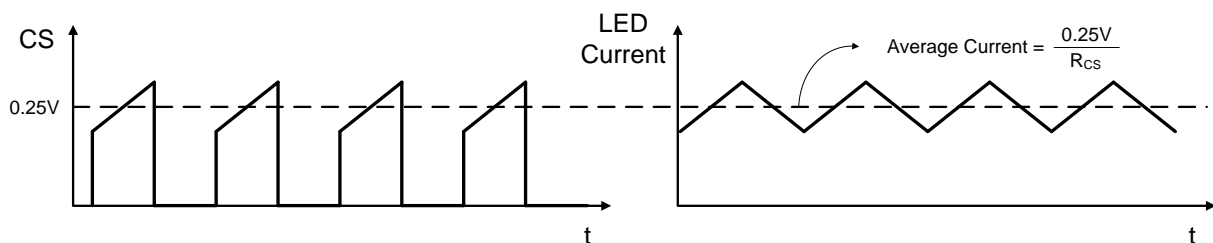

The above equations are only valid for continuous conduction of the output inductor. It is a good practice to design the inductor such that the switching ripple current in it is 15% of its average peak-to-peak, full load, DC current.

Output Short Circuit Protection

The short circuit protection comparator trips when the voltage at CS exceeds 0.6V. When this occurs, the GATE off-time $T_{HICCUP} = 1.2ms$ is generated to prevent stair-casing of the inductor current and potentially its saturation due to insufficient output voltage.

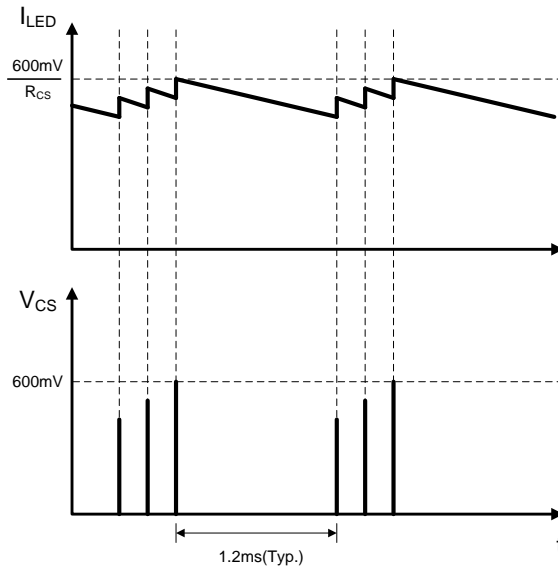

PWM Dimming

FP7127 operate in fast open-loop response of average-current control loop. The rising and falling edges are limited by the current slew rate in the inductor. The first switching cycle is terminated upon reaching the 275mV level at CS. The circuit is further reaching its steady-state within 1 switching cycles regardless of the switching frequency.

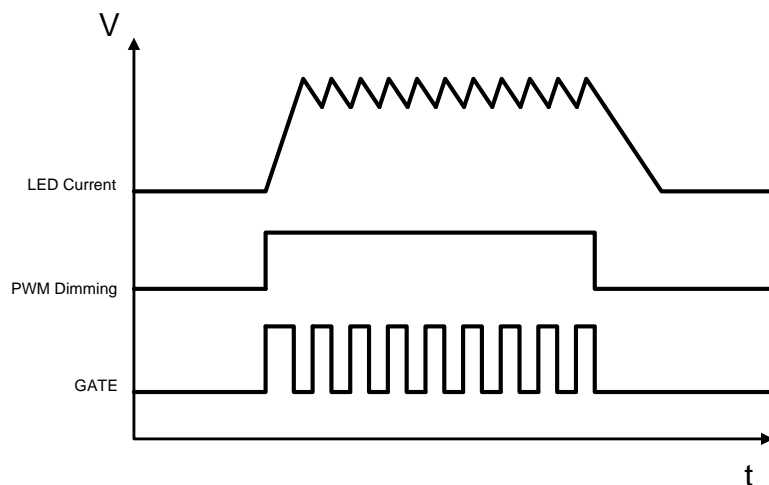

Application Curves

※ $V_{IN}=70V$, LED=52V, Inductor=120uH, $T_A = 25^\circ C$, unless otherwise noted

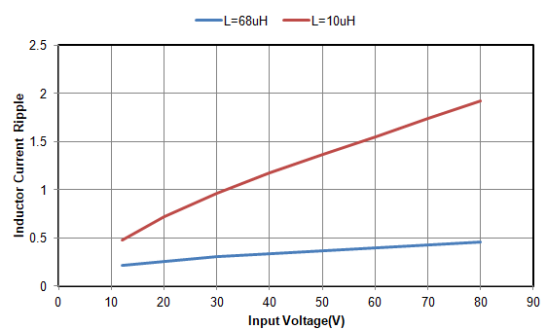
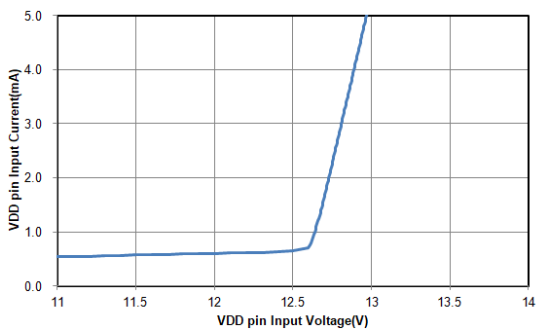
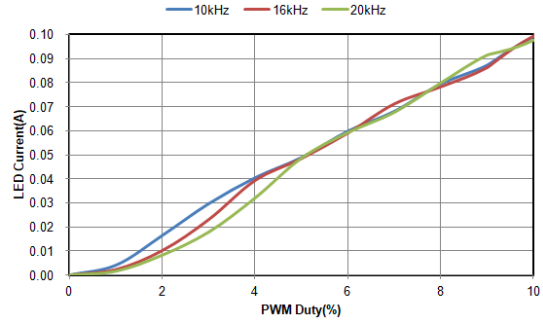
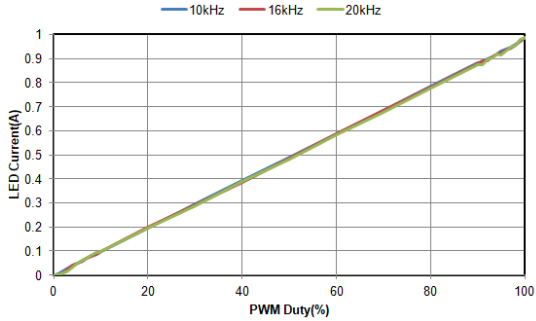
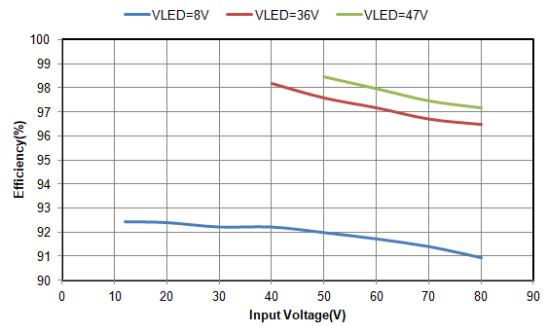
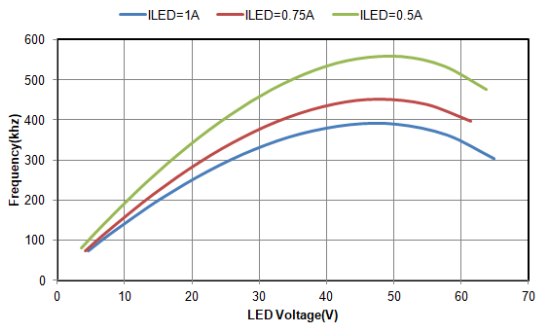
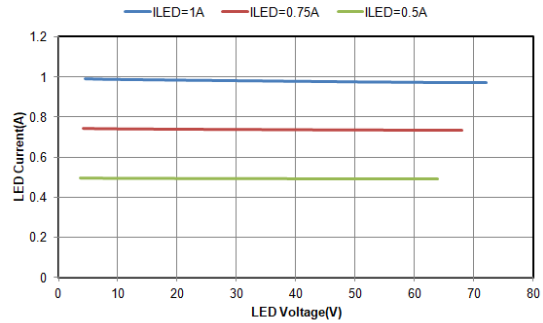
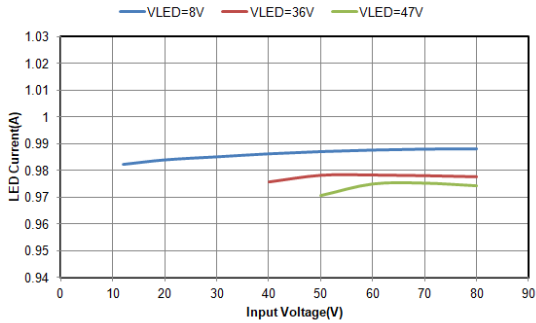

This datasheet contains new product information. Advanced Analog Technology reserves the rights to modify the product specification without notice. No liability is assumed as a result of the use of this product. No rights under any patent accompany the sales of the product.

※ $V_{IN}=70V$, $V_{LED}=52V$, Inductor=68uH, $T_A = 25^{\circ}C$, unless otherwise noted

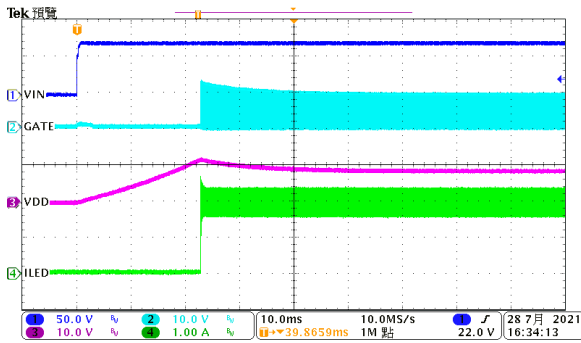

Power ON

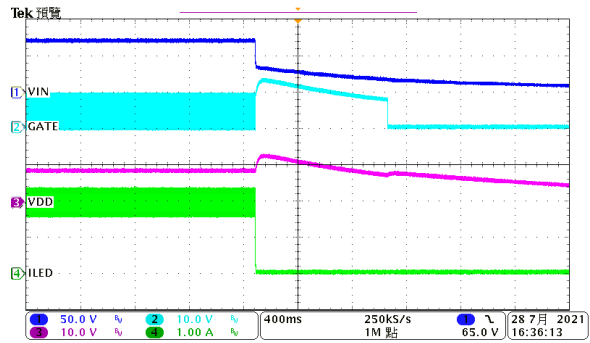

Power OFF

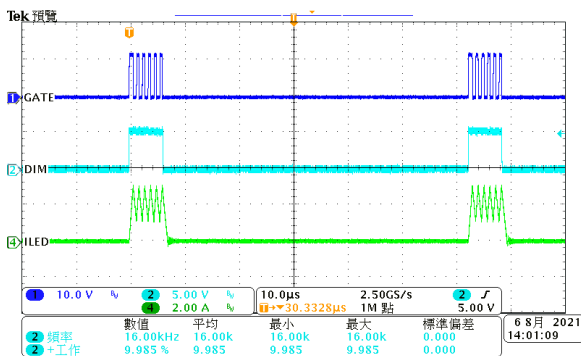

Dimming Duty=10%

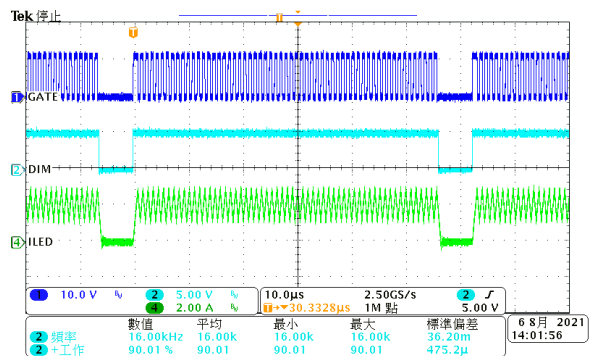

Dimming Duty=90%

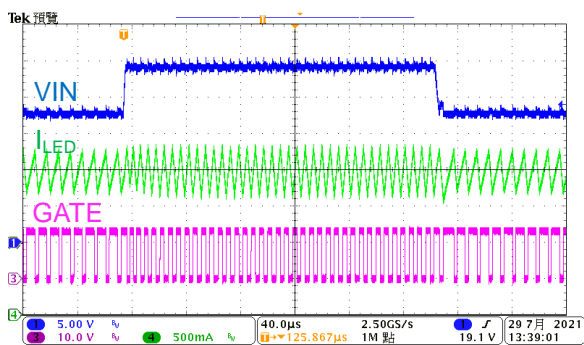

Input-Voltage Transient Response

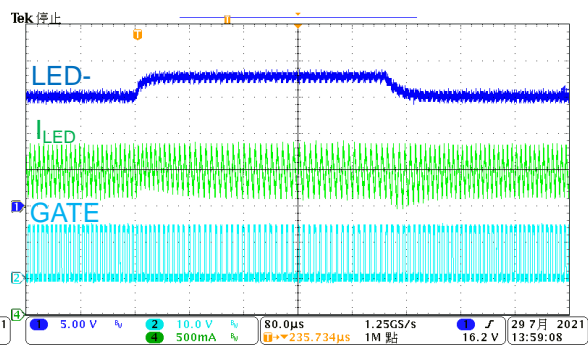

Output-Voltage Transient Response

This datasheet contains new product information. Advanced Analog Technology reserves the rights to modify the product specification without notice. No liability is assumed as a result of the use of this product. No rights under any patent accompany the sales of the product.

Suggested Layout

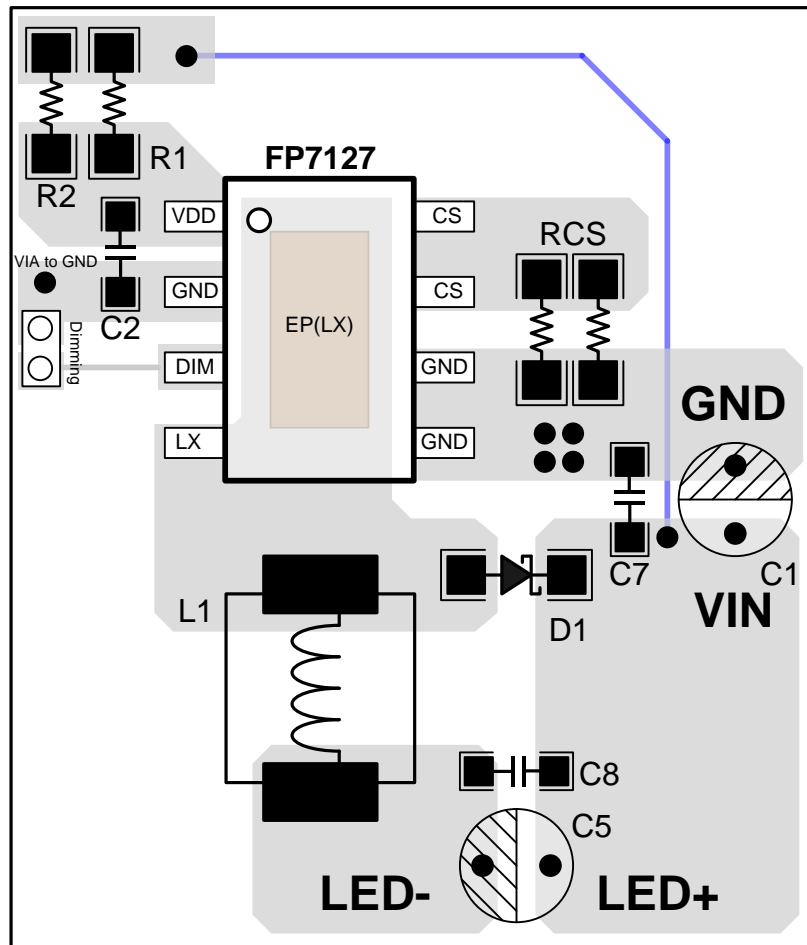

1. The power traces, consisting of the GND trace, the LX trace and the V_{IN} trace should be kept short, direct and wide.
2. Place C2 nearby VDD pin as closely as possible to maintain input voltage steady and filter noise.
3. CS pin are the sensitive nodes. Please keep it away from switching node.
4. The GND of the RCS、C1 and IC's GND pin should be connected close and together directly to a ground plane. GND should pour copper as large area as possible.
5. The V_{IN} of the D1 and C1 should be connected close and together directly.

Typical Application Circuit

- Input voltage range = 58V ~ 72V
- Output LED voltage = 52V
- Output LED current = 1A

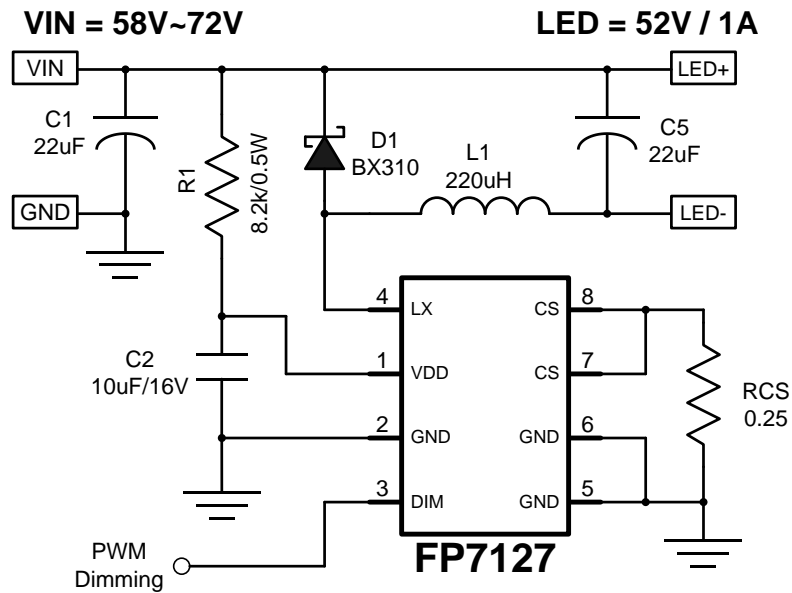

- Input voltage range = 48V
- Output LED voltage = 3V~42V
- Output LED current = 0.25A

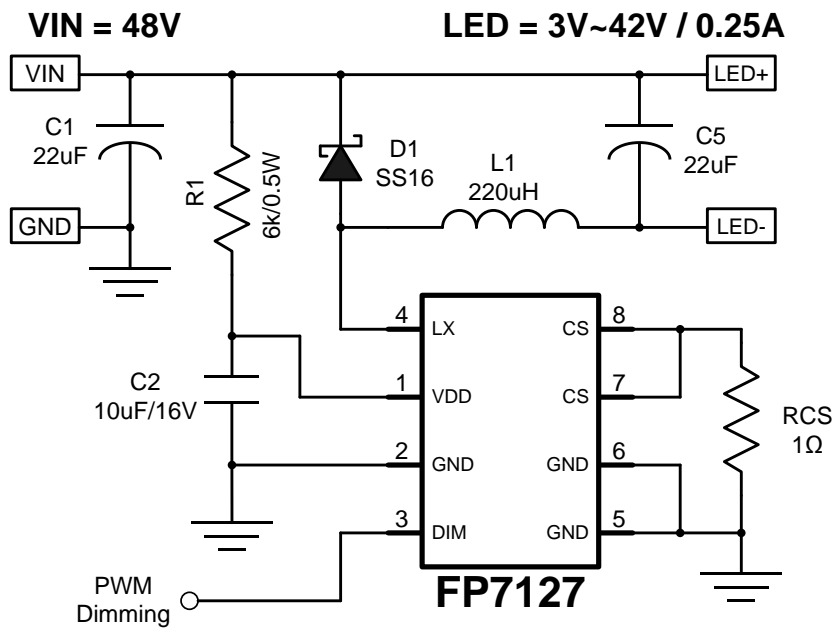

Package Outline

SOP-8L (EP)

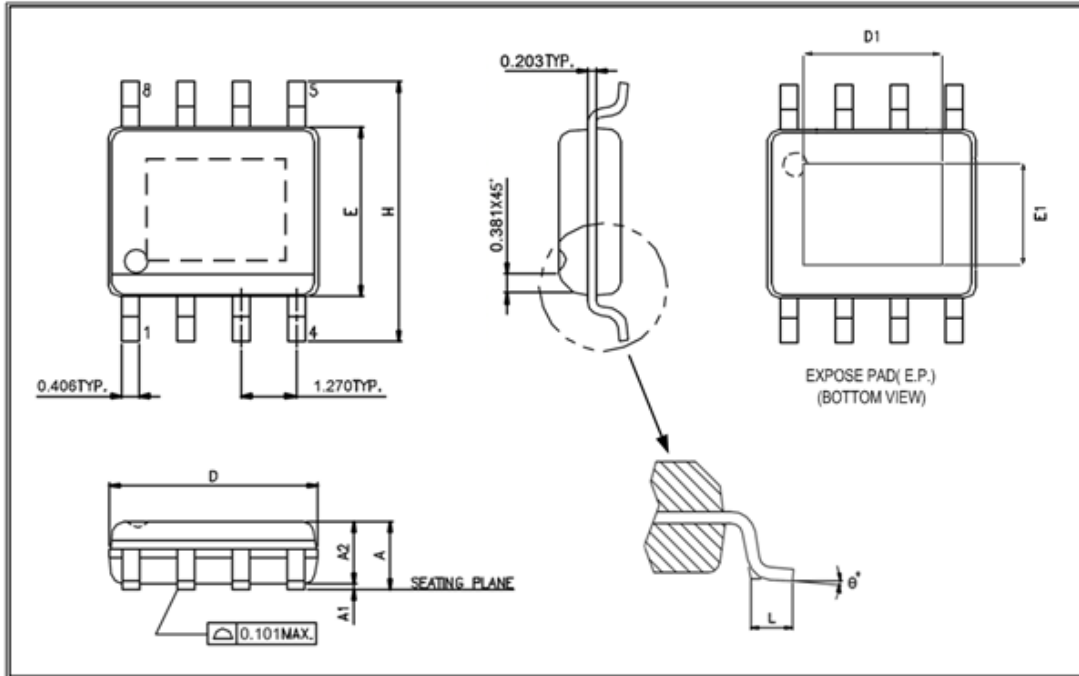

UNIT: mm

Symbols	Min. (mm)	Max. (mm)
A	1.30	1.70
A1	0	0.15
A2	1.25	1.55
D	4.70	5.10
E	3.80	4.00
H	5.80	6.20
L	0.40	1.27

Exposed PAD Dimensions:

Symbols	Min. (mm)	Max. (mm)
D1	2.60	3.45
E1	1.90	2.56

Note:

1. Package dimensions are in compliance with JEDEC outline: MS-012 AA.
2. Dimension "D" does not include molding flash, protrusions or gate burrs.
3. Dimension "E" does not include inter-lead flash or protrusions.