



Features

- Small Single MOSFETs
- $V_{DS} = -30\text{ V}$, $I_D = -4.1\text{ A}$
 $R_{DS(on)} < 60\text{ m}\Omega$ @ $V_{GS} = -10\text{ V}$
 $R_{DS(on)} < 85\text{ m}\Omega$ @ $V_{GS} = -4.5\text{ V}$
- Trench LV MOSFET Technology

Mechanical Characteristics

- SOT-23 Package
- Marking : Making Code
- RoHS Compliant

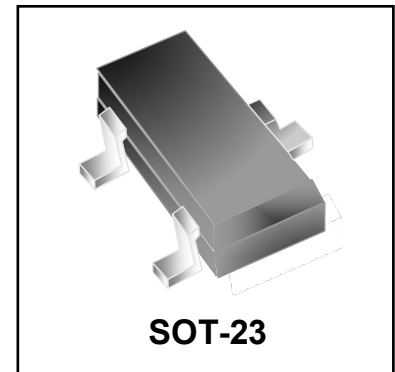

Schematic & PIN Configuration

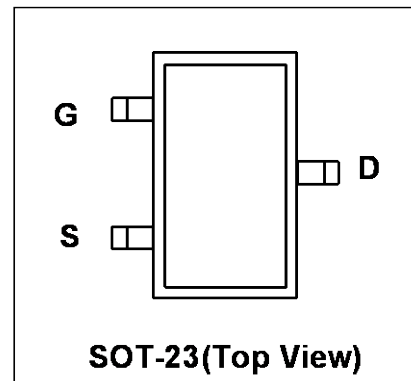
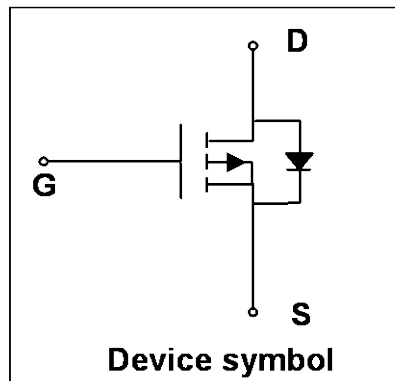

Absolute Maximum Rating ($T_A = 25^\circ\text{C}$ unless otherwise noted)

Parameter	Symbol	Value	Units
Drain-Source Voltage	V_{DS}	-30	V
Gate-Source Voltage	V_{GS}	± 20	V
Continuous Drain Current	I_D	-4.1	A
$T_A = 25^\circ\text{C}$			
Pulsed Drain Current ¹	I_{DM}	-16	A
Power Dissipation	P_D	1.2	W
$T_A = 25^\circ\text{C}$			
Junction and Storage Temperature Range	T_J, T_{STG}	-55 to +150	$^\circ\text{C}$

Thermal Characteristics

Parameter	Symbol	Value	Units
Thermal Resistance from Junction to Ambient ²	$R_{\theta JA}$	104	$^\circ\text{C/W}$

**Electrical Characteristics (T_J=25°C unless otherwise noted)**

Parameter	Symbol	Conditions	Min.	Typ.	Max.	Unit
Static Characteristics						
Drain-Source Breakdown Voltage	V_{(BR)DSS}	V _{GS} = 0V, I _D = -250μA	-30	-	-	V
Zero Gate Voltage Drain Current	I_{DSS}	V _{DS} = -30V, V _{GS} = 0V	-	-	-1	μA
Gate-Source Leakage	I_{GSS}	V _{DS} = 0V, V _{GS} = ±20V	-	-	±100	nA
Gate-Source Threshold voltage	V_{GS(th)}	V _{DS} = V _{GS} , I _D = -250μA	-1	-1.5	-2.5	V
Drain-Source on-State Resistance ³	R_{DS(on)}	V _{GS} = -10V, I _D = -4.1A	-	42	60	mΩ
		V _{GS} = -4.5V, I _D = -3A	-	54	85	
Dynamic Characteristics⁴						
Input Capacitance	C_{iss}	V _{GS} = 0V , V _{DS} = -15V, f = 1.0MHz	-	530	-	pF
Output Capacitance	C_{oss}		-	70	-	
Reverse Transfer Capacitance	C_{rss}		-	56	-	
Switching Characteristics⁴						
Total Gate Charge	Q_g	V _{GS} = -10V, V _{DS} = -15V, I _D = -4.1A	-	6.8	-	nC
Gate-Source Charge	Q_{gs}		-	1.0	-	
Gate-Drain Charge	Q_{gd}		-	1.4	-	
Turn-on Delay Time	t_{d(on)}	V _{GS} = -10V, V _{DS} = -15V , R _L = 15Ω,R _{GEN} = 2.5Ω	-	14	-	ns
Rise Time	t_r		-	61	-	
Turn-off Delay time	t_{d(off)}		-	19	-	
Fall Time	t_f		-	10	-	
Source-Drain Body Diode Characteristics						
Diode Forward Voltage ³	V_{SD}	I _S = -4.1A, V _{GS} = 0V	-	-	-1.2	V
Continuous Source Current	I_S		-	-	-4.1	A

Notes:

1. Repetitive Rating: Pulse width limited by maximum junction temperature.
2. Surface mounted on FR4 board using 1 square inch pad size, 1oz single-side copper.
3. Pulse Test: Pulse width≤300μs, duty cycle≤2%.
4. Guaranteed by design, not subject to product.



Typical Characteristics

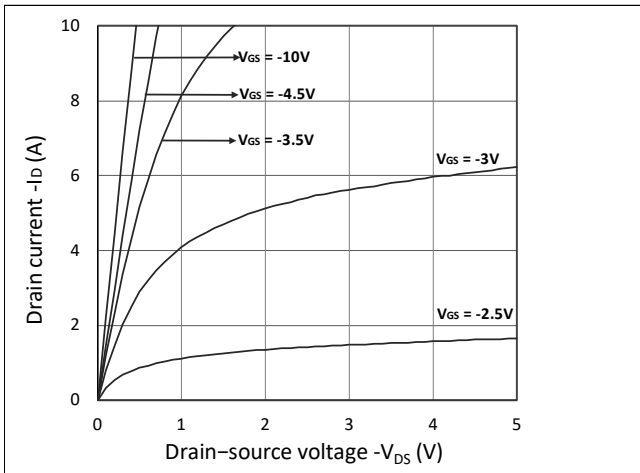

Figure 1. Output Characteristics

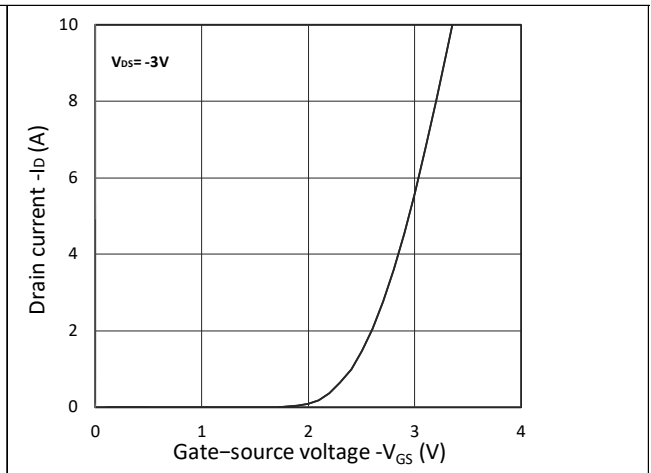

Figure 2. Transfer Characteristics

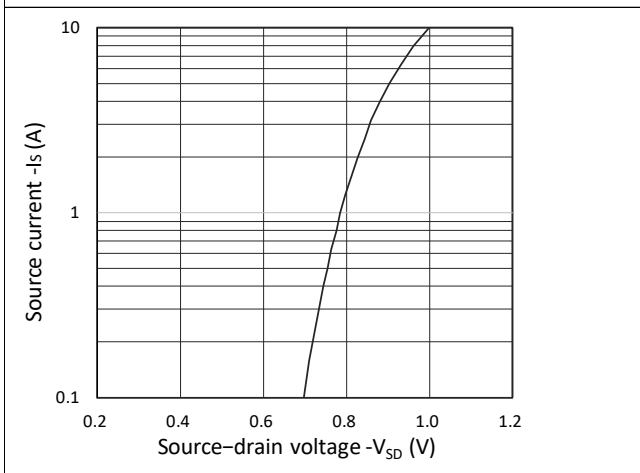

Figure 3. Forward Characteristics of Reverse

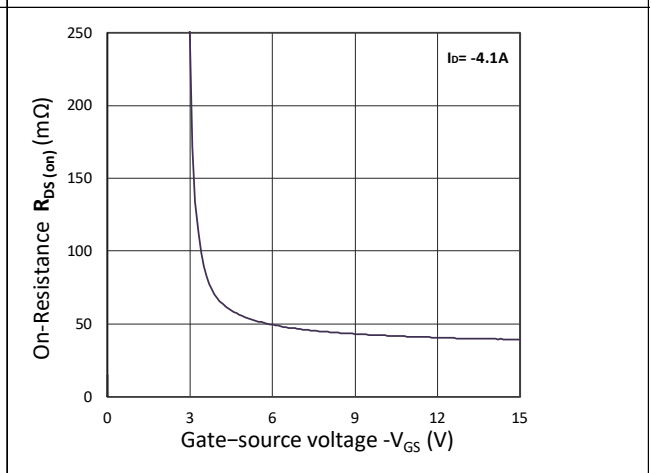

Figure 4. $R_{DS(on)}$ vs. V_{GS}

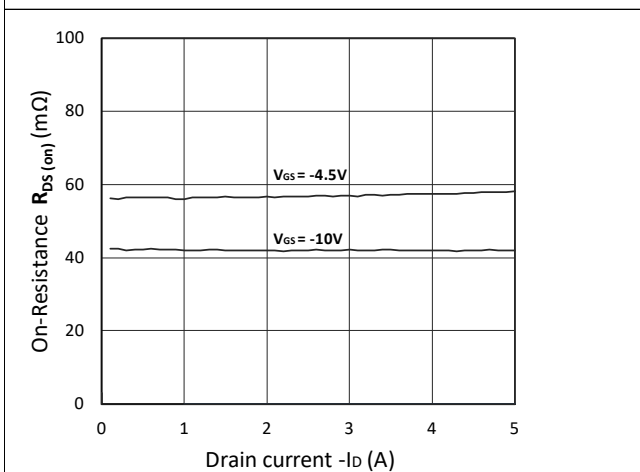

Figure 5. $R_{DS(on)}$ vs. I_D

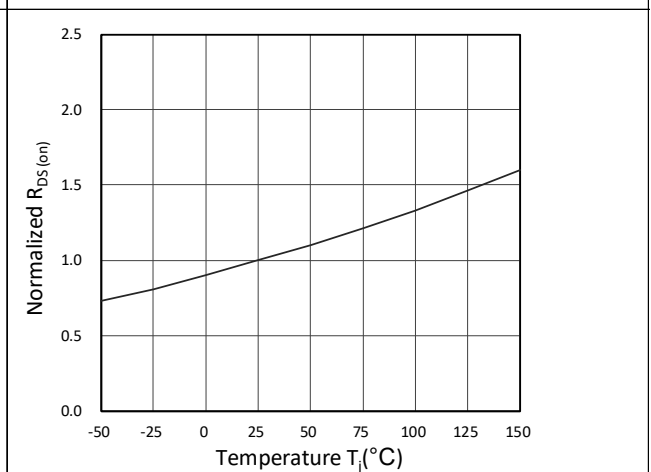

Figure 6. Normalized $R_{DS(on)}$ vs. Temperature

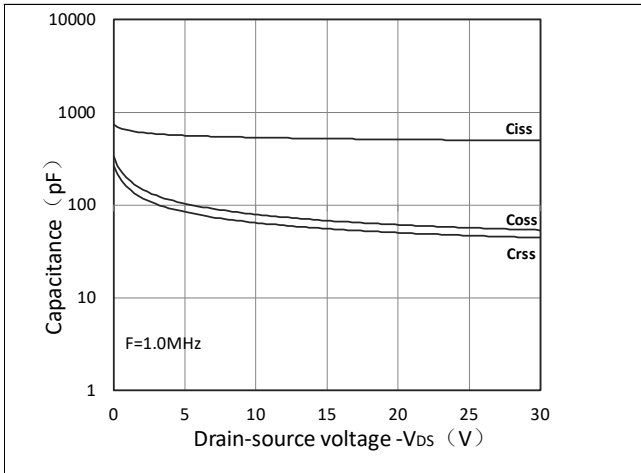

Figure 7. Capacitance Characteristics

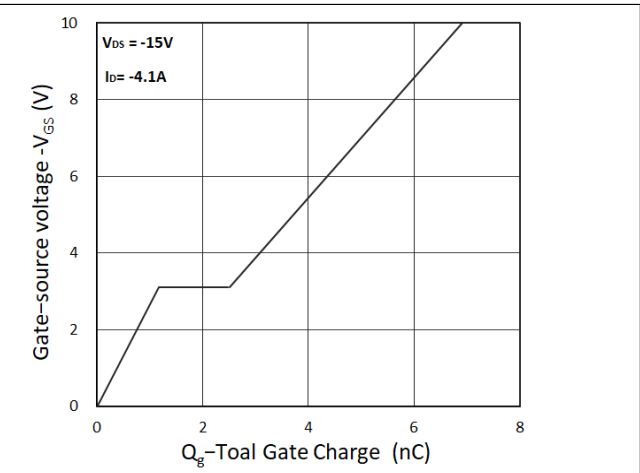

Figure 8. Gate Charge Characteristics



Outline Drawing – SOT-23

PACKAGE OUTLINE

SOT-23

DIMENSIONS

SYMBOL	MILLIMETER		INCHES	
	MIN	MAX	MIN	MAX
A	0.90	1.15	0.035	0.045
A1	0.00	0.10	0.000	0.004
b	0.30	0.50	0.012	0.020
c	0.08	0.15	0.003	0.006
D	2.80	3.00	0.110	0.118
E	2.25	2.55	0.089	0.100
E1	1.20	1.40	0.047	0.055
e	0.95 BSC		0.037BSC	
e1	1.80	2.00	0.071	0.079
L	0.55REF		0.022REF	
θ	0°	8°	0°	8°

DIMENSIONS		
DIM	INCHES	MILLIMETERS
M	0.080	2.02
C	0.032	0.80
Z	0.111	2.82
e	0.037 BSC	0.95 BSC
e1	0.075 BSC	1.90 BSC
b	0.032	0.80

Notes

1. Dimensioning and tolerances per ANSI Y14.5M, 1985.
2. Controlling Dimension: Inches
3. Pin 3 is the cathode (Unidirectional Only).
4. Dimensions are exclusive of mold flash and metal burrs.

Marking Codes

Part Number	WD3407
Marking Code	

Package Information

Qty: 3k/Reel