

### SOT-23-3

$V_{(BR)DSS}$	$R_{DS(on)Typ}$	$I_D Max$
30V	27mΩ@10V	5.8A
	29mΩ@4.5V	

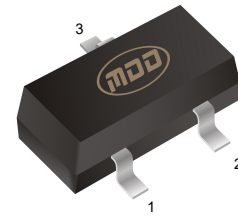

1. Gate
2. Source
3. Drain

### Features

High dense cell design for extremely low RDS(ON)  
Exceptional on-resistance and maximum DC current capability

### Application

- Load Switch for Portable Devices
- DC/DC Converter

### Marking

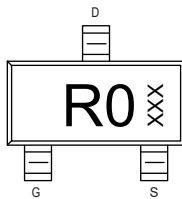

XXX:Date Code

### Equivalent Circuit

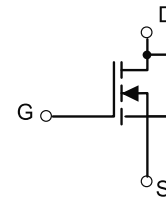

### Absolute Maximum Ratings ( $T_A=25^\circ\text{C}$ unless otherwise noted)

Parameter	Symbol	Value	Unit
Drain-Source Voltage	$V_{DS}$	30	V
Gate-Source Voltage	$V_{GS}$	±12	V
Continuous Drain Current	$I_D$	5.8	A
Pulsed Drain Current (Note 1)	$I_{DM}$	23	A
Power Dissipation(Note 2)	$P_D$	1.5	W
Thermal Resistance from Junction to Ambient(Note 2)	$R_{\theta JA}$	100	$^\circ\text{C}/\text{W}$
Junction Temperature and Storage Temperature	$T_J, T_{stg}$	-50 ~150	$^\circ\text{C}$

Notes: Stresses exceeding Maximum Ratings may damage the device. Maximum Ratings are stress ratings only. Functional operation above the Recommended Operating Conditions is not implied. Extended exposure to stresses above the Recommended Operating Conditions may affect device reliability.



**Ta = 25°C unless otherwise specified**

Symbol	Parameter	Condition	Min	Typ	Max	Unit
$V_{(BR)DSS}$	Drain-Source Breakdown Voltage	$V_{GS}=0V, I_D=250\mu A$	30	--	--	V
$I_{DSS}$	Drain-Source Leakage Current	$V_{DS}=24V, V_{GS}=0V$	--	--	1	$\mu A$
$I_{GSS}$	Gate-Source Leakage Current	$V_{GS}=\pm 12V, V_{DS}=0V$	--	--	$\pm 100$	nA
$V_{GS(TH)}$	Gate Threshold Voltage	$V_{DS}=V_{GS}, I_D=250\mu A$	0.5	0.8	1.2	V
$R_{DS(ON)}$	Drain-Source On-State Resistance(Note 3)	$V_{GS}=10V, I_D=5.8A$	--	27	32	m $\Omega$
		$V_{GS}=4.5V, I_D=5A$	--	29	35	m $\Omega$
		$V_{GS}=2.5V, I_D=4A$	--	34	45	m $\Omega$

### Dynamic Electrical Characteristics

Symbol	Parameter	Condition	Min	Typ	Max	Unit
$C_{iss}$	Input Capacitance	$V_{DS}=15V$ $V_{GS}=0V$ $f=1MHz$	--	635	--	pF
$C_{oss}$	Output Capacitance		--	135	--	pF
$C_{rss}$	Reverse Transfer Capacitance		--	40	--	pF
$Q_g$	Total Gate Charge	$V_{DS}=15V$	--	10.5	--	nC
$Q_{gs}$	Gate Source Charge	$V_{GS}=4.5V$	--	1.6	--	nC
$Q_{gd}$	Gate Drain Charge	$I_D=5A$	--	2.7	--	nC

### Switching Characteristics

Symbol	Parameter	Condition	Min	Typ	Max	Unit
$t_{d(on)}$	Turn on Delay Time	$V_{DS}=15V$ $V_{GS}=4.5V$ $I_D=5A$ $R_G=3.3\Omega$	--	7.5	--	ns
$t_r$	Turn on Rise Time		--	18	--	ns
$t_{d(off)}$	Turn Off Delay Time		--	36	--	ns
$t_f$	Turn Off Fall Time		--	5	--	ns

### Source Drain Diode Characteristics

Symbol	Parameter	Condition	Min	Typ	Max	Unit
$I_{SD}$	Source drain current(Body Diode)	$T_A=25^\circ C$	--	--	1.5	A
$V_{SD}$	Drain-Source Diode Forward Voltage	$I_S=3A, V_{GS}=0V$	--	0.82	1.2	V

- Notes:**
- 1.Pulse width limited by maximum allowable junction temperature
  - 2.The value of  $P_D$  &  $R_{\theta JA}$  is measured with the device mounted on 1 in<sup>2</sup> FR-4 board with 2oz.Copper, double sided, in a still air environment with  $T_a=25^\circ C$ .
  - 3.Pulse test ; Pulse width $\leq 300\mu s$ , duty cycles $\leq 2\%$

### Typical Characteristics

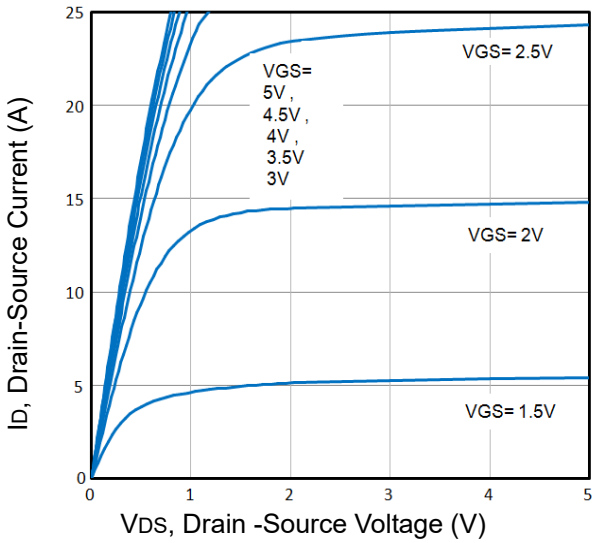

**Fig1.** Typical Output Characteristics

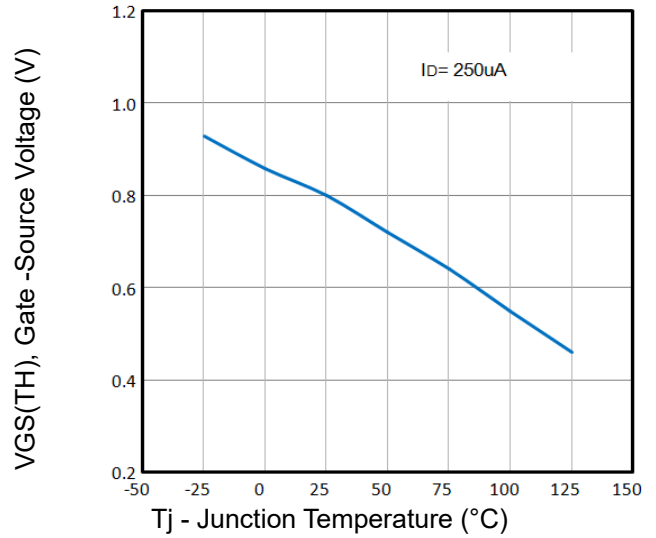

**Fig2.** Normalized Threshold Voltage Vs. Temperature

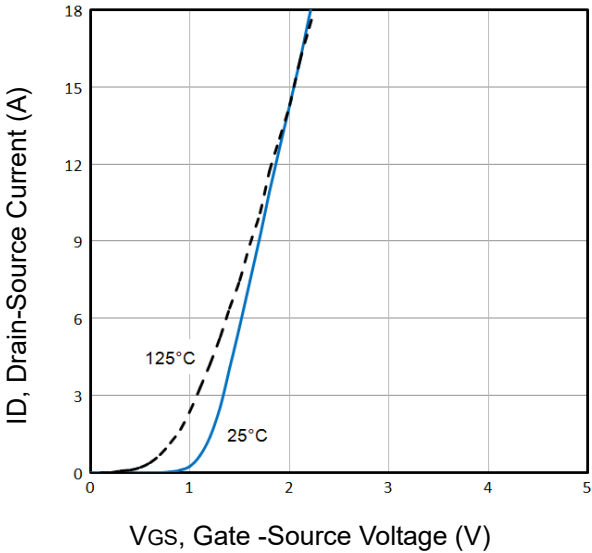

**Fig3.** Typical Transfer Characteristics

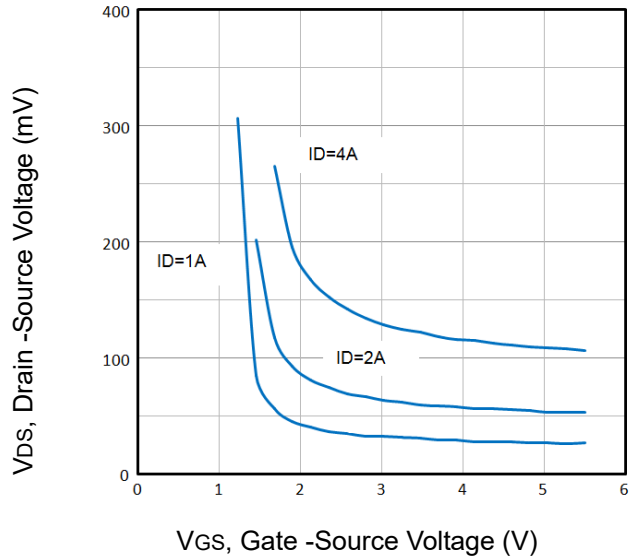

**Fig4.** Drain-Source Voltage vs Gate-Source Voltage

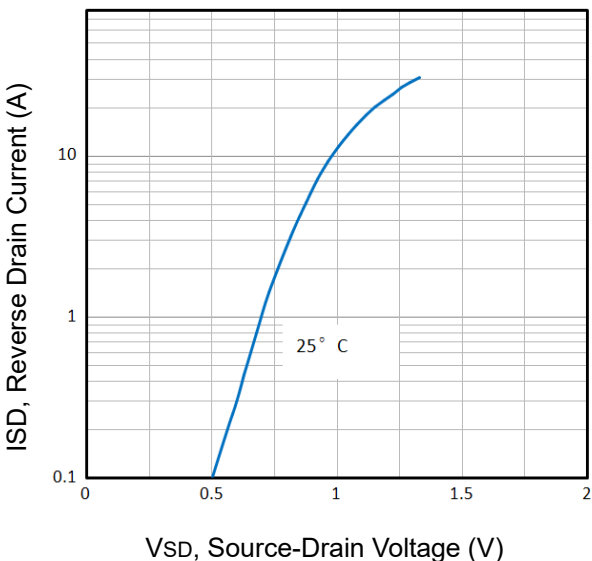

**Fig5.** Typical Source-Drain Diode Forward Voltage

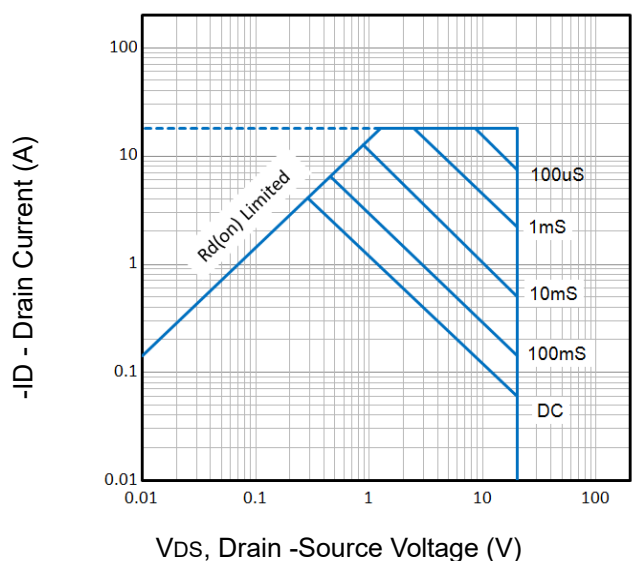

**Fig6.** Maximum Safe Operating Area

The curve above is for reference only.

### Typical Characteristics

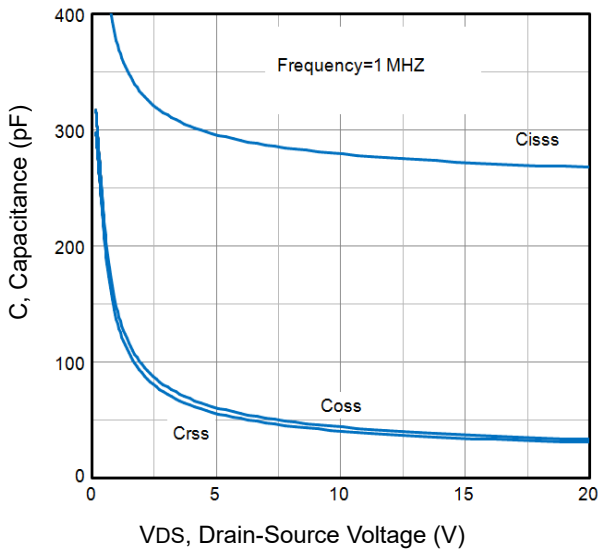

**Fig7.** Typical Capacitance Vs. Drain-Source Voltage

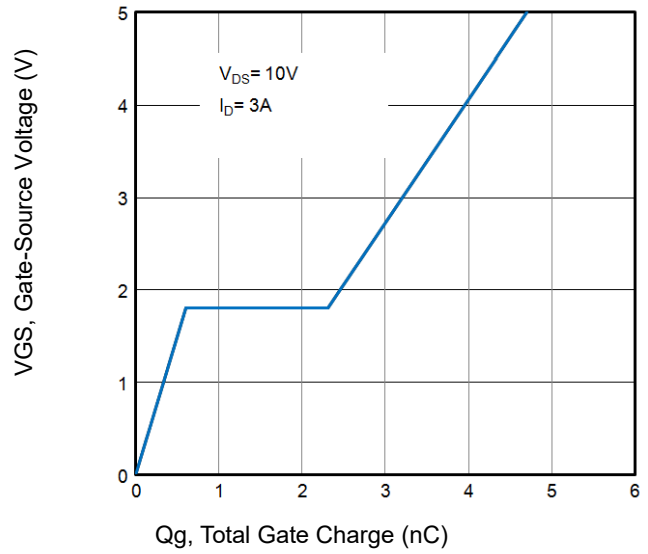

**Fig8.** Typical Gate Charge Vs. Gate-Source Voltage

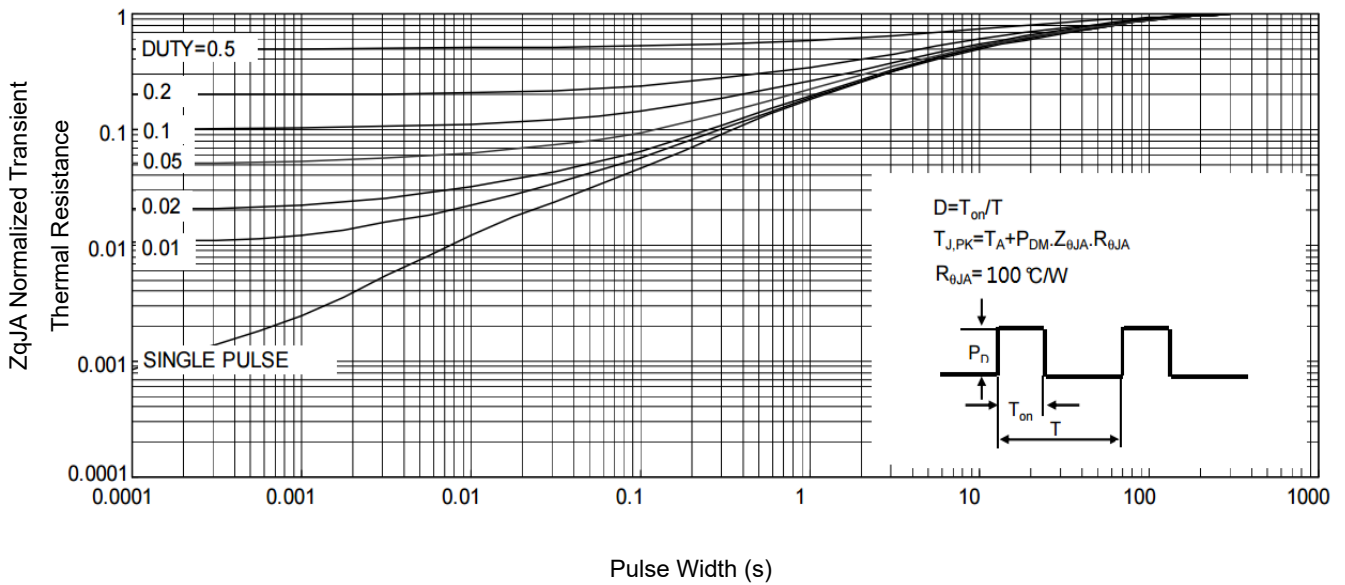

**Fig9.** Normalized Maximum Transient Thermal Impedance

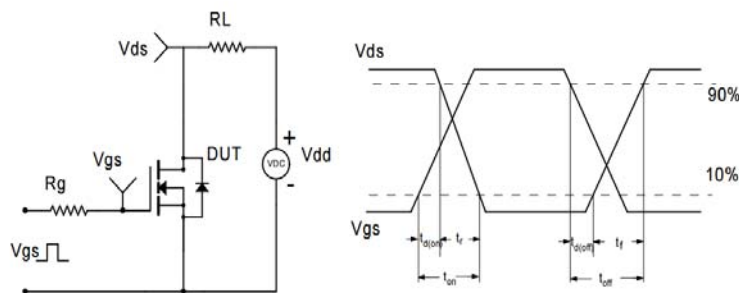
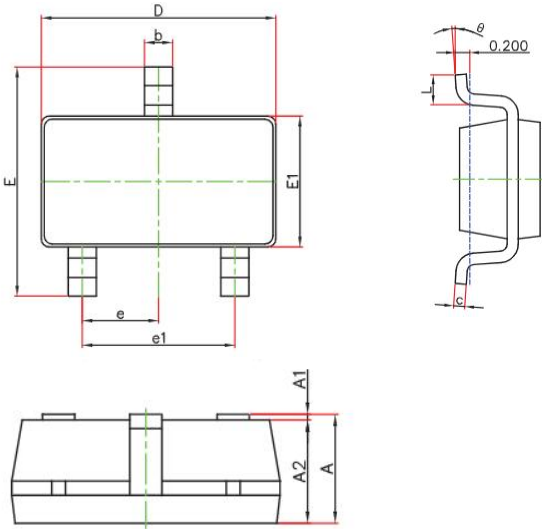

**Fig10.** Switching Time Test Circuit and waveforms

The curve above is for reference only.

### Outline Drawing

#### SOT-23-3 Package Outline Dimensions



Symbol	Dimensions In Millimeters		Dimensions In Inches	
	Min.	Max.	Min.	Max.
A	1.050	1.250	0.041	0.049
A1	0.000	0.100	0.000	0.004
A2	1.050	1.150	0.041	0.045
b	0.300	0.500	0.012	0.020
c	0.100	0.200	0.004	0.008
D	2.820	3.020	0.111	0.119
E1	1.500	1.700	0.059	0.067
E	2.650	2.950	0.104	0.116
e	0.950(BSC)		0.037(BSC)	
e1	1.800	2.000	0.071	0.079
L	0.300	0.600	0.012	0.024
θ	0°	8°	0°	8°

### Suggested Pad Layout

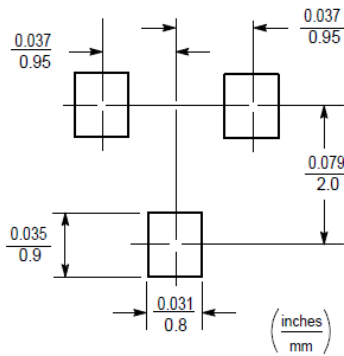

**Note:**

1. Controlling dimension: in/millimeters.
2. General tolerance:  $\pm 0.05\text{mm}$ .
3. The pad layout is for reference purposes only.