

SURFACE MOUNT SCHOTTKY BARRIER RECTIFIER

SS12 THRU SS110

FEATURES

- Low Turn-on Voltage
- Fast Switching
- PN Junction Guard Ring for Transient and ESD Protection
- Designed for Surface Mount Application
- Classification 94V-O

Mechanical Data

- Case: SOD-123FL, Molded Plastic
- Terminals: Plated Leads Solderable per MIL-STD-202, Method 208
- Polarity: Cathode Band
- Weight: 0.017 grams (approx.)

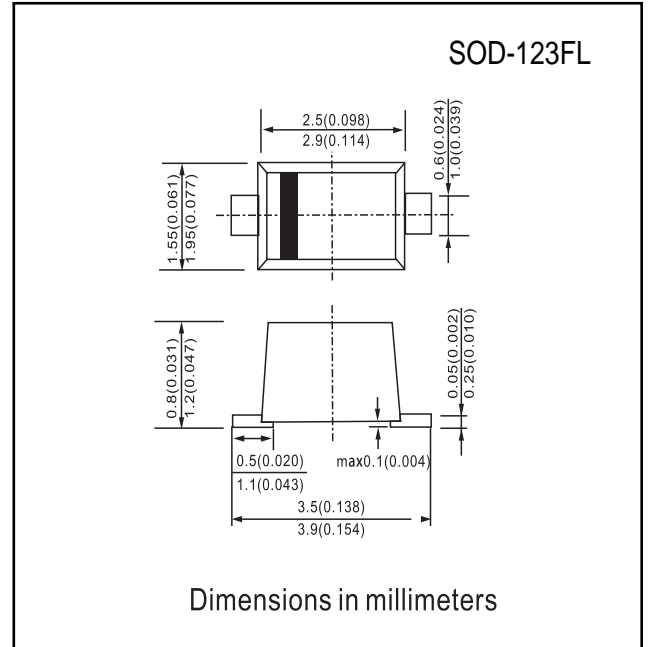

MAXIMUM RATINGS AND ELECTRICAL CHARACTERISTICS

Maximum Ratings @ $T_A=25^\circ\text{C}$ unless otherwise specified

Characteristic	Symbol	SS12	SS14	SS16	SS18	SS110	UNIT
Peak Repetitive Reverse Voltage	V_{RRM}						V
Working Peak Reverse Voltage	V_{RWM}	20	40	60	80	100	
DC Blocking Voltage	V_R						
Forward Continuous Current (Note 1)	I_F	1.0					A
Non-Repetitive Peak Forward Surge Current 8.3ms Single half sine-wave superimposed on rated load (JEDEC Method)	I_{FSM}	25					A
Power Dissipation (Note 1)	P_d	450					mW
Operating and Storage Temperature Range	T_j, T_{STG}	-65 to +125					$^\circ\text{C}$

Electrical Characteristics @ $T_A=25^\circ\text{C}$ unless otherwise specified

Characteristic	Symbol	DSK12	DSK14	DSK16	DSK18	DSK110	UNIT
Forward Voltage Drop @ $I_F = 1.0\text{A}$	V_{FM}	0.45	0.55	0.55	0.70	0.85	V
Peak Reverse Leakage Current @ V_{RRM}	I_{RM}	500					μA
Typical Junction Capacitance	C_j	50					pF

Note: 1. Valid provided that terminals are kept at ambient temperature.

SURFACE MOUNT SCHOTTKY BARRIER RECTIFIER SS12 THRU SS110

RATINGS AND CHARACTERISTIC CURVES SS12 THRU SS110

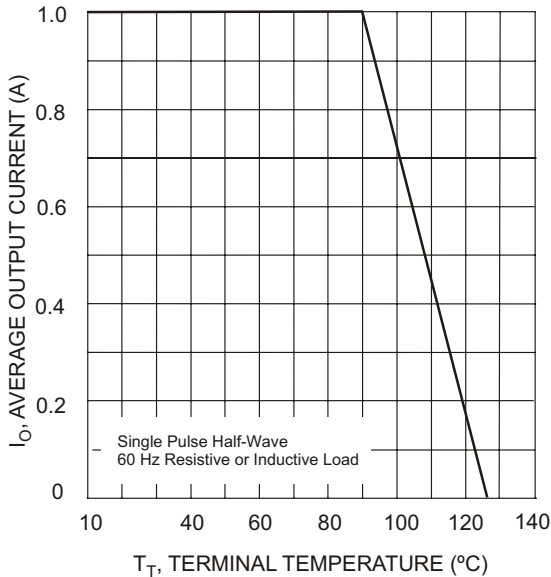

Fig. 1 Forward Current Derating Curve

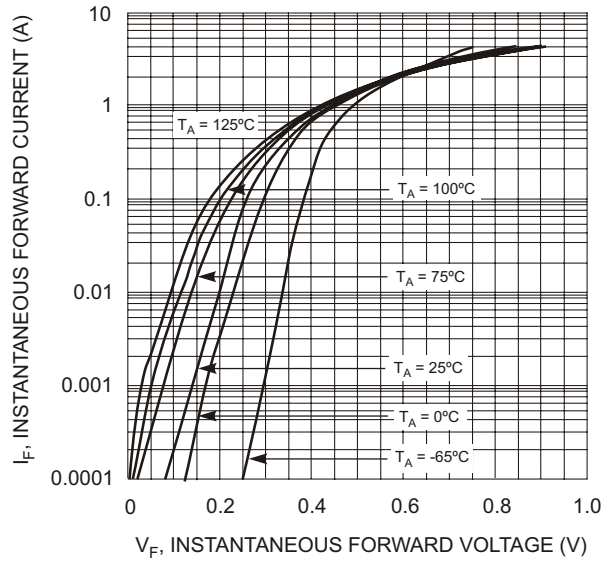

Fig. 2 Typical Forward Characteristics

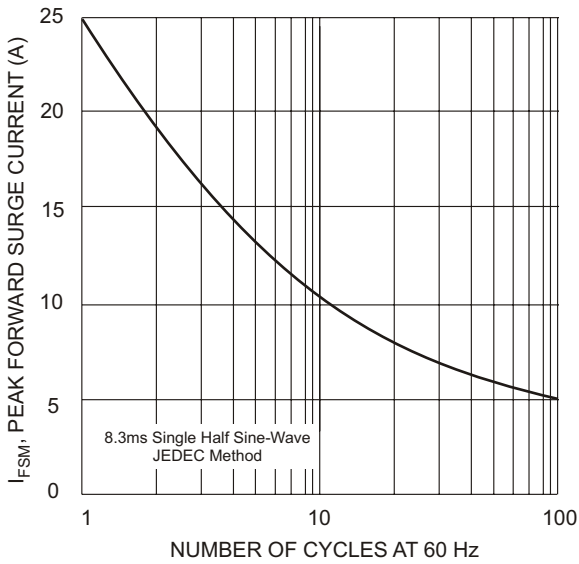

Fig. 3 Maximum Non-Repetitive Peak Fwd Surge Current

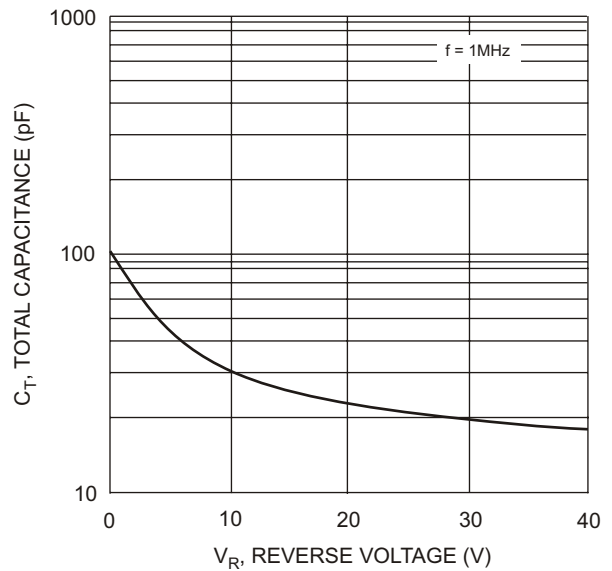

Fig. 4 Typical Total Capacitance