

编号	SCTF202305027
日期	2023/5/4
版本	A02



# 承认书

## SPECIFICATION FOR APPROVAL

客户名称 Customer Name:	立创商城
供应商物料名称 Part Name:	石英晶体谐振器
产品描述 Description:	TF2012 32.768KHz/6pF
供应商物料料号 Part NO.:	DXTF201232768D20F
供应商名称 Supplier Name :	深圳市星通时频电子有限公司

PLEASE CONFIRM OUR SPECIFICATION. 敬请确认规格书之内容。

CUSTOMER APPROVAL 客户审批		
物料代号 PART NO. _____		
使用于机型 USED IN MODEL: _____		
工程部	品质部	采购部

(敬请承认后返回一份，谢谢!)

SUPPLIER APPROVAL 供应商审批		
DGN.制表人	CKD. 校对	APPD. 审核、签章
吴丽红	李良	胡华才

<b>Revision Record</b>				
Rev.	Revise page 修订页	Revise contents 修订内容	Rev. Date 修订日期	Reviser 修订人
A02	N/A	Initial released.	2022/4/1	Martin.Hu

SHENZHEN SCTF ELECTRONICS CO., LTD		
DATE	Specification of quartz crystal 石英晶体谐振器规格书	Page:
2023/5/4	P/N: DXTF201232768D20F Spec.NO.: SCTF202305027	2

## ■ QUARTZ CRYSTAL UNIT SPECIFICATION

Crystal Unit Spec:

N0.	Item	Symb.	Electrical spec.	Notes
1	Product Type 产品型号	-	TF2012	
2	Nominal Frequency 标称频率	f	32.768kHz	
3	Operating Temperature 工作温度范围	T <sub>use</sub>	-40~85℃	
4	Storage Temperature Range 存储温度	T <sub>stg</sub>	-40~105℃	
5	Oscillation Mode 振荡模式	-	Fundamental	
6	Frequency Tolerance 常温频差	f <sub>tol</sub>	±20ppm	at 25℃±3℃
7	Turnover Temperature 拐点温度	T <sub>i</sub>	25℃±5℃	
8	Parabolic curvature constant 频率温度系数	B	-0.042 PPM/(Δ℃) <sup>2</sup> MAX	Over Operating Temp. Range (Reference 25℃)
9	Drive Level 激励功率	DL	0.5 μW Max.	See the 2.1
10	Load Capacitance 负载电容	CL	6pF	See the 2.2
11	Effective Resistance R <sub>r</sub> 谐振电阻	RR	80kΩ Max.	
12	Motional Capacitance C <sub>1</sub> 动态电容	C <sub>1</sub>	4.6fF Tye.	
13	Shunt Capacitance C <sub>0</sub> 静电容	CO	1.1 pF Tye.	
14	Quality Factor 品质因素	Q	13000 Min	
15	Aging 老化率	f <sub>age</sub>	±3 ppm	25℃, 1st Year
16	Others其他	ROHS		

Notes:

2.1 Drive Level (DL)

0.5 μW Max.

(If Drive Level is too high, that may cause crystal resonator abnormal oscillation or damaged the main body of quartz.)

2.2 Loading capacitance (CL) : 6pF

(The total circuit load capacitance should be equal to the crystal (CL) values, too large or too small load, will result in frequency drift.)

SHENZHEN SCTF ELECTRONICS CO. , LTD		
DATE	Specification of quartz crystal 石英晶体谐振器规格书	Page:
2023/5/4	P/N: DXTF201232768D20F Spec.NO.: SCTF202305027	3

## ■ PRODUCT STRUCTURE & MARKING

### ◆ Product Structure 产品结构

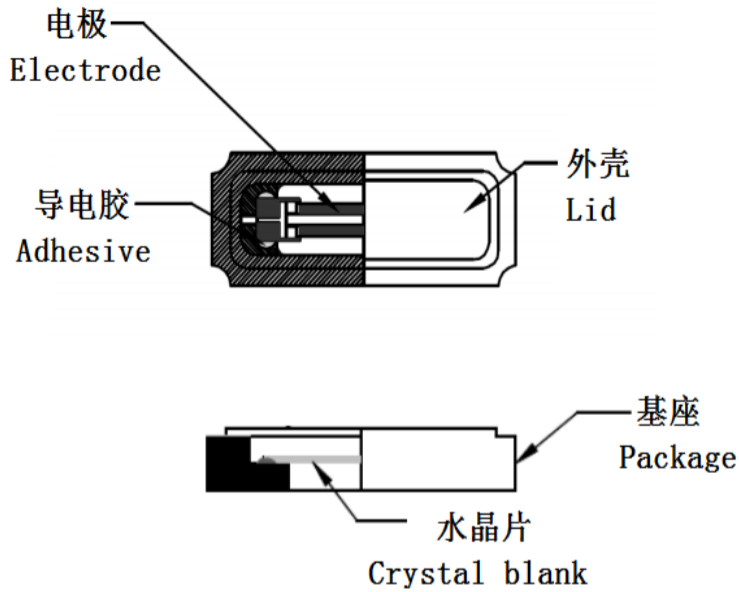

### ◆ Marking 印字

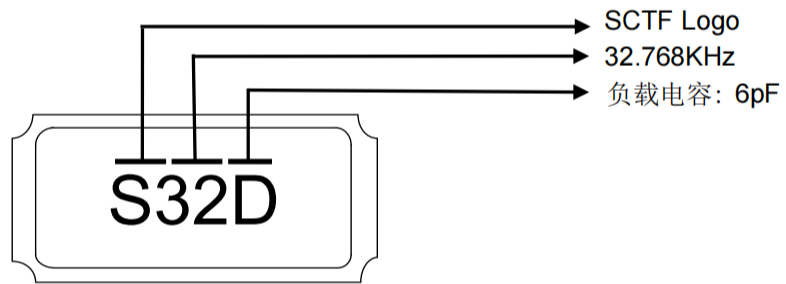

#### 1. 超声波清洗或者焊接 Ultrasonic cleaning or welding

恶劣的超声波清洗或超声波焊接可能会影响和损坏石英晶体元件。如果您对晶体元件进行了超声波清洗，请一定在使用前确认晶体元件是否受到了影响和损坏。

Crystal units may be affected and destroyed at worst by supersonic cleaning or supersonic welding. Please be sure to check if your cleaning and welding process affects any damage to crystal units before using.

#### 2. 手工焊建议条件 Recommended conditions for manual welding

温度:  $350 \pm 10^\circ\text{C}$ , 时间: 3 秒 Max, 次数: 2 次 Max. Temperature:  $350 \pm 10^\circ\text{C}$ , Time: 3 sec max, Re-solder times: twice max.

SHENZHEN SCTF ELECTRONICS CO., LTD		
DATE	Specification of quartz crystal 石英晶体谐振器规格书	Page:
2023/5/4	P/N: DXTF201232768D20F Spec.NO.: SCTF202305027	4

## ■ DIMENSIONS

产品尺寸 (Product size)

Units (单位): mm(毫米)

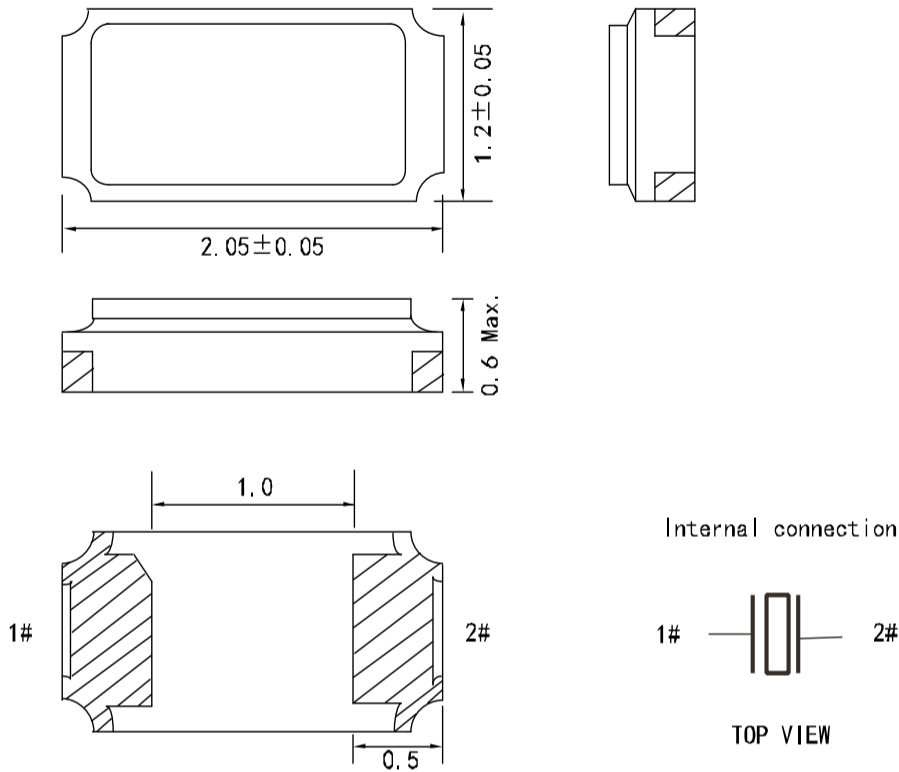

焊盘尺寸 (Pad size)

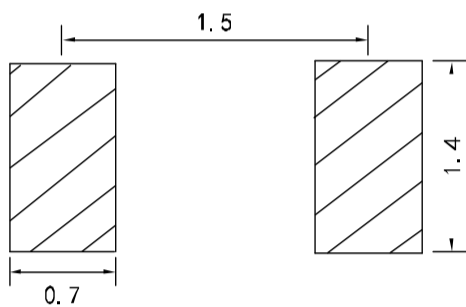

\*建议勿在晶体底部设计信号线。

SHENZHEN SCTF ELECTRONICS CO. , LTD		
DATE	Specification of quartz crystal 石英晶体谐振器规格书	Page:
2023/5/4	P/N: DXTF201232768D20F Spec.NO.: SCTF202305027	5

## REFLOW PROFILES

Profile Feature	Sn-Pb Eutectic Assembly	Pb-Free Assembly
Preheat/Soak		
● Temperature Min ( $T_s$ min)	100 °C	150 °C
● Temperature Max ( $T_s$ max)	150 °C	200 °C
● Time ( $T_s$ min to $T_s$ max)	60-120 seconds	60-120 seconds
Ramp-up rate ( $T_L$ to $T_p$ )	3 °C/second max.	3 °C/second max.
Time maintained above		
● Liquidous temperature ( $T_L$ )	183 °C	217 °C
● Time ( $t_L$ ) maintained above $T_L$	60-150 seconds	60-150 seconds
Peak package body temperature ( $T_p$ )	235 °C	260 °C
Time within 5 °C of the specified classification temperature ( $T_p$ )	20 seconds	30 seconds
Ramp-down rate ( $T_p$ to $T_L$ )	6 °C/second max.	6 °C/second max.
Time 25 °C to peak temperature	6 minutes max.	8 minutes max.
<b>Suggest reflow times</b>	<b>2 Times max.</b>	

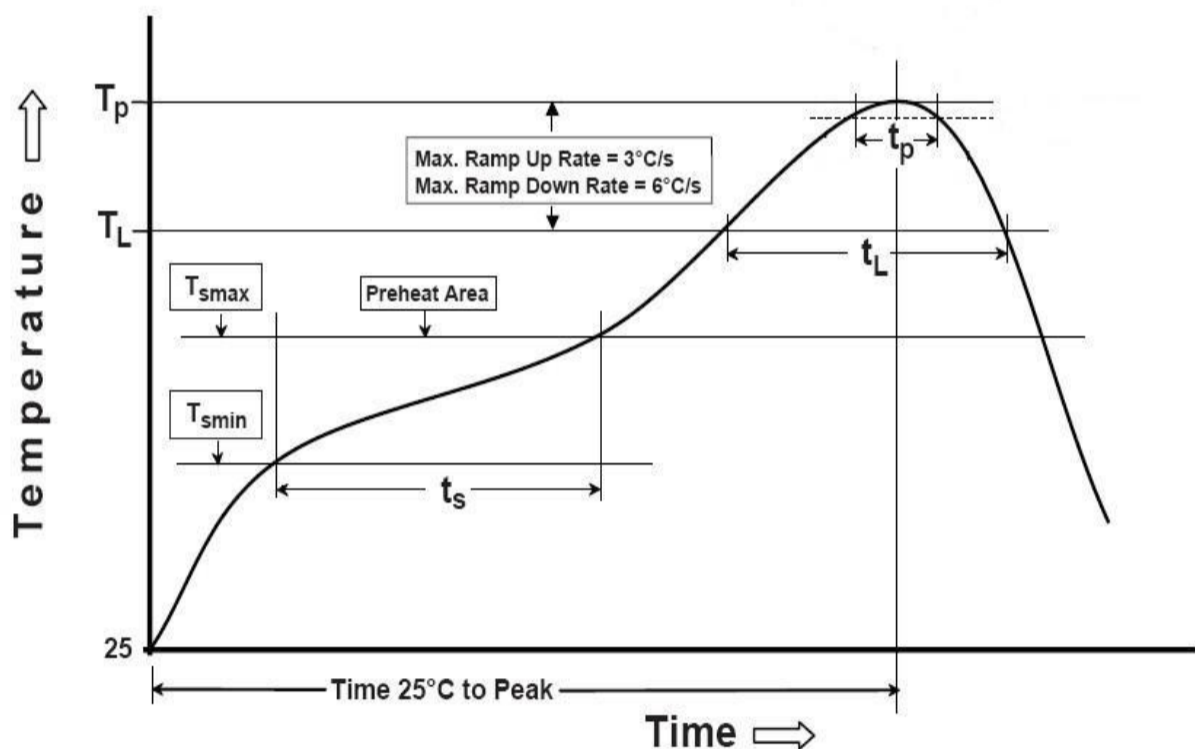

SHENZHEN SCTF ELECTRONICS CO., LTD

DATE	Specification of quartz crystal 石英晶体谐振器规格书	Page:
2023/5/4	P/N: DXTF201232768D20F Spec.NO.: SCTF202305027	6

## RELIABILITY SPECIFICATION

序号 NO.	项目 ITEM	条件 CONDITIONS	合格标准 BASIS OF VERDICT
1	跌落 DROP	150cm高处自由跌落到水泥地板上,3次 High:150cm;cement floor;3 times.	$\Delta FL \leq \pm 20 \text{ppm}$ $\Delta RR \leq RR(\text{max}) * 10\%$
2	振动 VIBRATION	频率 Frequency:10~57.7Hz;幅度 Amplitude: $\pm 0.75 \text{mm}$ 频率Frequency:57.7Hz~500Hz;加速度幅度acceleration rate:98m/s <sup>2</sup> 周期 Cycle time:10-500-10Hz: 15min 振动方向 Direction:X,Y, Z 振动时间 Duration: 每个方向2小时 2 h/direction.	$\Delta FL \leq \pm 10 \text{ppm}$ $\Delta RR \leq RR(\text{max}) * 10\%$
3	温度变化 TEMPERATURE SHOCK	-40°C $\pm 2^\circ\text{C}$ (30min) $\leftrightarrow$ 85°C $\pm 2^\circ\text{C}$ (30min);循环10次 -40°C $\pm 2^\circ\text{C}$ (30min) $\leftrightarrow$ 85°C $\pm 2^\circ\text{C}$ (30min);For 10 cycles	$\Delta FL \leq \pm 10 \text{ppm}$ $\Delta RR \leq RR(\text{max}) * 10\%$
4	湿热 HUMIDITY	温度:40°C $\pm 2^\circ\text{C}$ ;湿度90-95%;时间:96小时 Temp:40°C $\pm 2^\circ\text{C}$ ;Humidity:90-95%;Times:96h	$\Delta FL \leq \pm 10 \text{ppm}$ $\Delta RR \leq RR(\text{max}) * 10\%$
5	低温 COLD RESISTANCE	温度:-40°C $\pm 2^\circ\text{C}$ ;时间:96小时 Temp:-40°C $\pm 2^\circ\text{C}$ ;Times:96h	$\Delta FL \leq \pm 10 \text{ppm}$ $\Delta RR \leq RR(\text{max}) * 10\%$
6	高温 HEAT RESISTANCE 1	温度:125°C $\pm 2^\circ\text{C}$ ;时间:96小时 Temp:125°C $\pm 2^\circ\text{C}$ ;Times:96h	$\Delta FL \leq \pm 10 \text{ppm}$ $\Delta RR \leq RR(\text{max}) * 10\%$
7	回流焊 REFLOW	150°C $\pm 5^\circ\text{C}$ 保持120s后升到260°C $\pm 5^\circ\text{C}$ 保持10s, 升温 and 保温 时间小于200s, 常温放置1~2h后测定 Keep 150 °C $\pm 5^\circ\text{C}$ 120s and then rose to 260 °C $\pm 5^\circ\text{C}$ for 10s, warming and holding time is less than the 200s, placed at room temperature 1 ~ 2h after test	$\Delta FL \leq \pm 20 \text{ppm}$ $\Delta RR \leq RR(\text{max}) * 10\%$
8	老化 AGING	温度:85°C;时间:30天 Temp:85°C;Times:30days	$\Delta FL \leq \pm 5 \text{ppm}$ $\Delta RR \leq RR(\text{max}) * 10\%$
9	气密性 LEAKAGE	氦气(0.6~0.65MPa):10分钟 He(0.6~0.65MPa):10min	$\leq 3 * 10^{-9} \text{Pa} \cdot \text{m}^3/\text{s}$
10	焊接 SOLDER	温度:235°C $\pm 5^\circ\text{C}$ Temp:235°C $\pm 5^\circ\text{C}$	浸锡率大于90% Soldering tin rate greater than 90%
11	折板弯曲试验 TERMINAL STRENGTH	弯曲度: 3mm,保持时间: 5sec,速度: 0.5mm/sec Bending: 3mm, Hold time: 5sec, Speed: 0.5mm/sec	$\Delta FL \leq \pm 10 \text{ppm}$ $\Delta RR \leq RR(\text{max}) * 10\%$
12	折板推力试验 STICKING TENDENCY	荷重: 10N, 保持时间: 10 秒, 治具: R0.5(制品侧边位置) Load: 10N, Hold time: 10 seconds, Fixture: R0.5 (product side position)	$\Delta FL \leq \pm 10 \text{ppm}$ $\Delta RR \leq RR(\text{max}) * 10\%$
13	本体荷重试验 ELEMENT ASSEMBLY STRENGTH	荷重: 10N, 保持时间: 10 秒, 治具: R0.5(制品中心位置) Load: 10N, Hold time: 10 seconds, Fixture: R0.5 (product center position)	$\Delta FL \leq \pm 10 \text{ppm}$ $\Delta RR \leq RR(\text{max}) * 10\%$

### SHENZHEN SCTF ELECTRONICS CO. , LTD

DATE	Specification of quartz crystal 石英晶体谐振器规格书	Page:
2023/5/4	P/N: DXTF201232768D20F Spec.NO.: SCTF202305027	7

## PACKAGE

Units (单位): mm(毫米)

### ◆ Tape dimensions

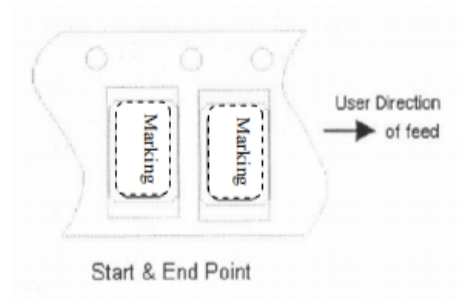
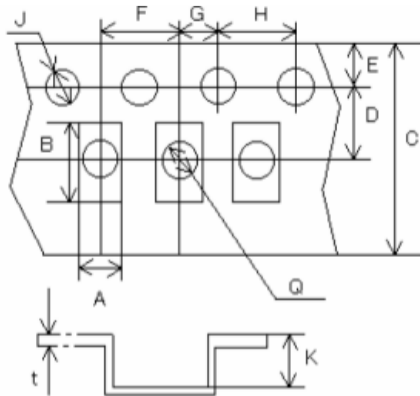

A	B	C	D	E	F	G	H	J	K	t
1.4	2.3	8.0	3.5	1.75	4.0	2.0	4.0	1.5	0.75	0.25

备注 REMARK:

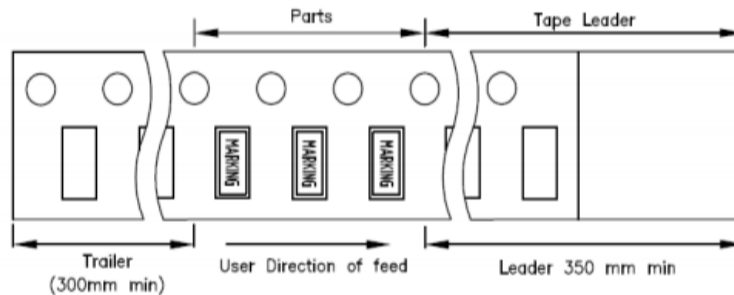

### ◆ Real dimensions

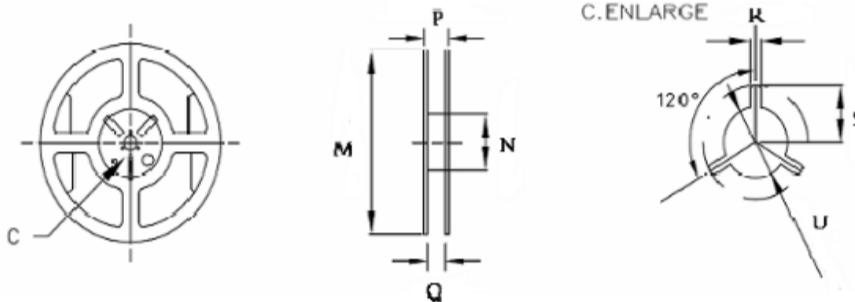

M	N	P	Q	R	S	U
178	60.2	11.5	8.0	2.5	11.0	13.0

圆卷 Reel: 3000 pcs/Reel

Notes:

储存温度说明 Storage temperature description

储存温度仅适用于产品，而包装材料储存温度 5℃~40℃。

Storage Temperature is only for the product itself, the temperature for the packing material is 5℃~40℃.

SHENZHEN SCTF ELECTRONICS CO., LTD		
DATE	Specification of quartz crystal 石英晶体谐振器规格书	Page:
2023/5/4	P/N: DXTF201232768D20F Spec.NO.: SCTF202305027	8