

NO.	ECN NO.	DESCRIPTION	REV.	DRAW	DATE
1		新版发行	A0	廖振纲	20200728

ELECTRICAL SPECIFICATIONS@25°C UNLESS OTHERWISE NOTED:

- 1.Turn Ratio(+/-2%):1CT:1CT
- 2.Inductance OCL:
350uH Min @100KHz 0.1V DC BIAS 8mA
- 3.Insertion Loss:
-1.0dB Max @1.0-100MHz
- 4.Return Loss:
-20dB Min @1-30MHz
-16dB Min @30-60MHz
-12dB Min @60-80MHz
- 5.Cross talk:
-40dB Min @1-30MHz
-35dB Min @30-80MHz
- 6.Common Mode Rejection:
-35dB Min @1-100MHz
-20dB Min @50-150MHz
- 7.HIPOT TEST:1500Vrms 1mA.Max
- 8.DC CURRENT /
VOLTAGE RATING - PSE PINS: 600mA MAX
@54V DC (CONTINUOUS) 30W

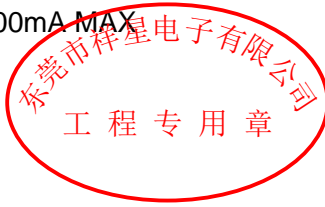

SCHEMATICS:

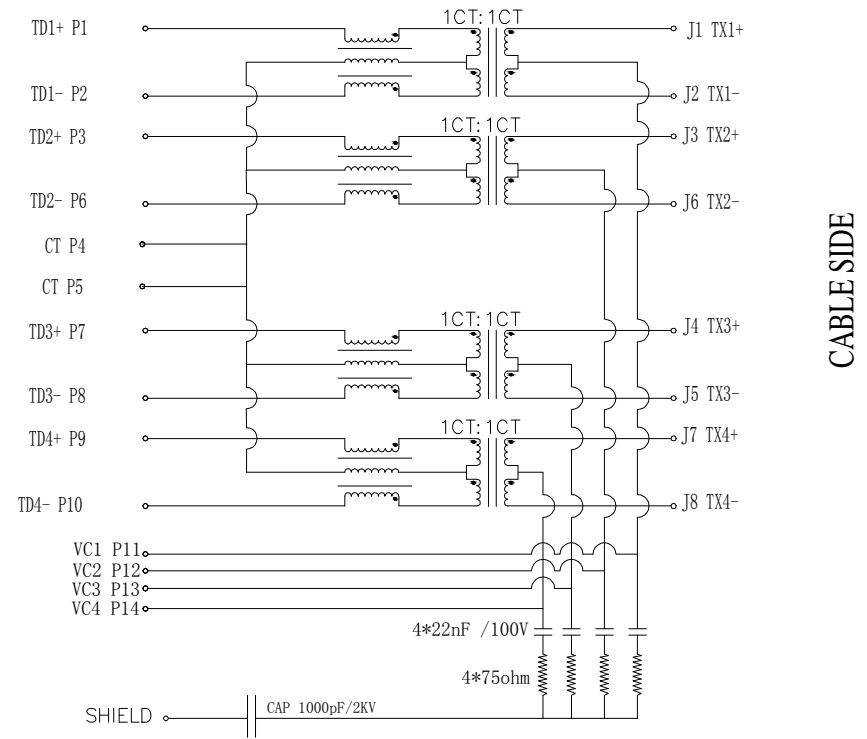

未注公差 TOLERANCE UNLESS OTHERWISE SPECIFIED			E-NETTR 东莞市祥星电子有限公司 DONGGUANG XIANGXING ELECTRONICS CO., LTD Miss yang:13694998066 Mr Li:15013501940 TEL:0769-86384669 FAX:0769-81813600 Http://www.e-nettr.com xxing.guang@163.com		
比例 SCALE		角法 PROJ.	设计 DESIGN	品号 ITEM NO.	300514
张数 SHEET	2/2	纸张 SIZE	A4	品名 TITLE	GR04M1HXS014
单位 UNIT	mm	版本 REV.	A0	规格 DESC.	