

承 认 书

SPECIFICATION FOR APPROVAL

SN-LT3030GAKA40KG-Z

宁波协源光电科技股份有限公司

Ningbo Shining Opto Electronics Co;Ltd.

Company Name:	NSO	
	Prepared by:	Approval by:
Confirmed By Customer:		

Feature

- △ Viewing angle:120 deg
- △ The materials of the LED dice is InGaN
- △ 3.2mm×3.0mm×0.6mm
- △ Pb-free
- △ RoHS compliant lead-free soldering compatible
- △ ESD protection

Package Outline

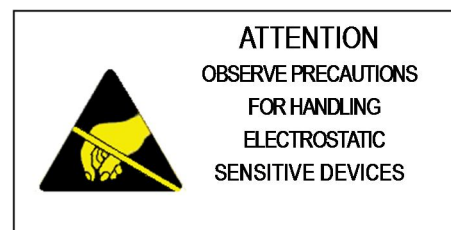
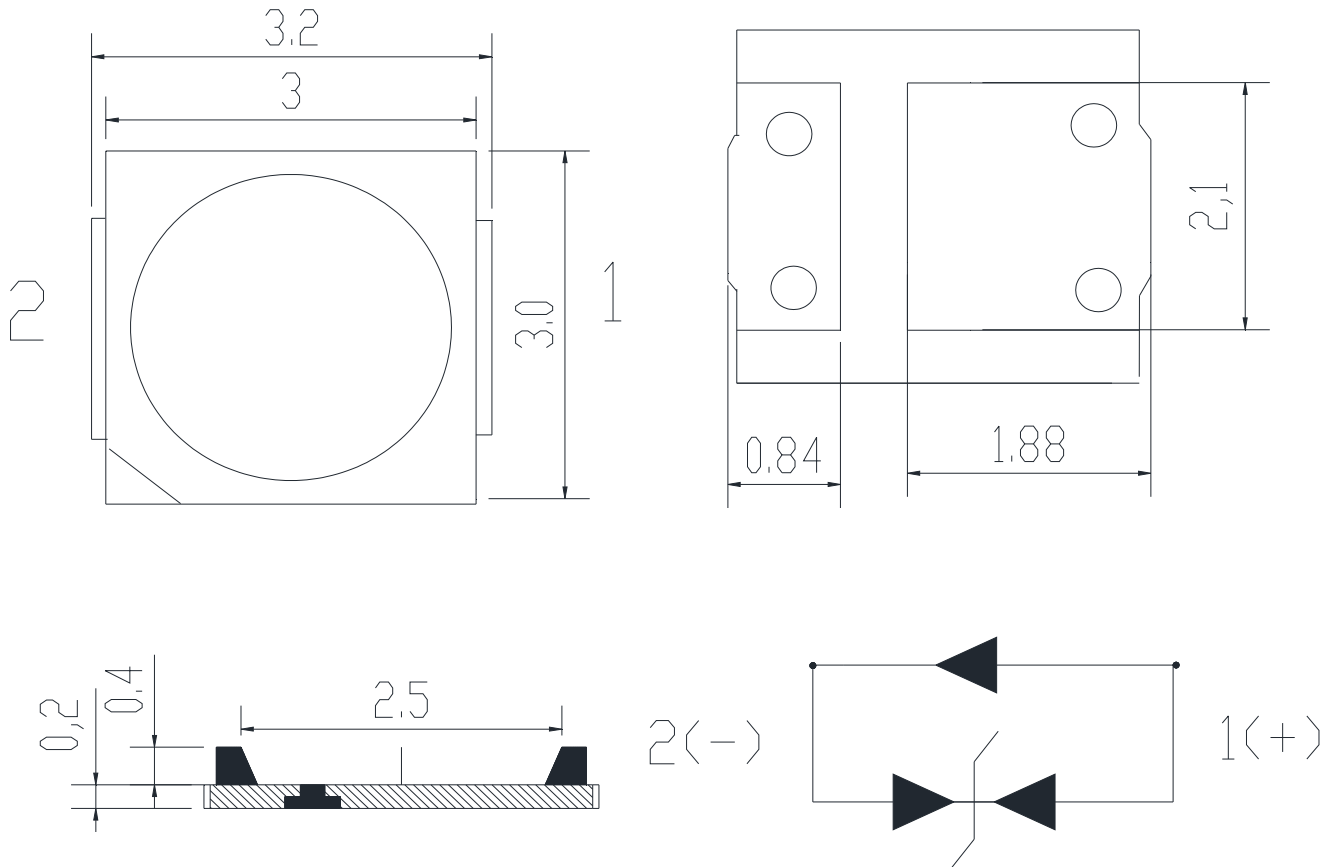

NOTES:

1. All dimensions are in millimeters ;
2. Tolerances are ± 0.2 mm unless otherwise noted.

Absolute maximum ratings at Ta=25°C

Parameter	Symbol	Value	Unit
Forward current	I _f	350	mA
Reverse voltage	V _r	5	V
Operating temperature range	T _{op}	-35 ~+85	°C
Storage temperature range	T _{stg}	-40~+95	°C
Pulse Forward Current (Pulse Width ≦ 1 msec. and Duty ≦ 1/10)	I _{fp}	1000	mA
Electrostatic Discharge HBM	ESD	Class 3A JESD22-A114	V

Electro-optical characteristics at Ta=25°C

Parameter	Test Condition	Symbol	Value			Unit
			Min.	Typ.	Max.	
Forward voltage	I _f =350mA	V _f	2.8	--	3.6	V
Luminous intensity	I _f =350mA	Φ	130	--	155	lm
Viewing angle at 50% I _v	I _f =350mA	2θ 1/2	--	120	--	Deg
Reverse current	V _r =5V	I _r	--	--	10	μA

NOTE: (Tolerance: Φ±15%, V_f ±0.1V, X/ Y ±0.015)

Forward voltage range

Forward Voltage Unit: V @350mA		
Bin Code	MIN	MAX
VF12	2.8	2.9
VF13	2.9	3.0
VF14	3.0	3.1
VF15	3.1	3.2
VF16	3.2	3.3
VF17	3.3	3.4
VF18	3.4	3.5
VF19	3.5	3.6

Luminous intensity range

Luminous intensity Unit: lm @350mA		
Bin Code	MIN	MAX
C58	130	134
C59	134	138
C60	138	142
C61	142	146
C62	146	150
C63	150	155

Chromaticity range

BIN	X	Y	BIN	X	Y	BIN	X	Y
40D 3700-3800K	0.386	0.3693	40G 3800-4200K	0.3688	0.3589	40H 4200-4300K	0.3657	0.3568
	0.3953	0.4011		0.3751	0.3883		0.3714	0.3858
	0.4005	0.4044		0.3953	0.4011		0.3751	0.3883
	0.3904	0.3719		0.386	0.3693		0.3688	0.3589

Chromaticity Bin

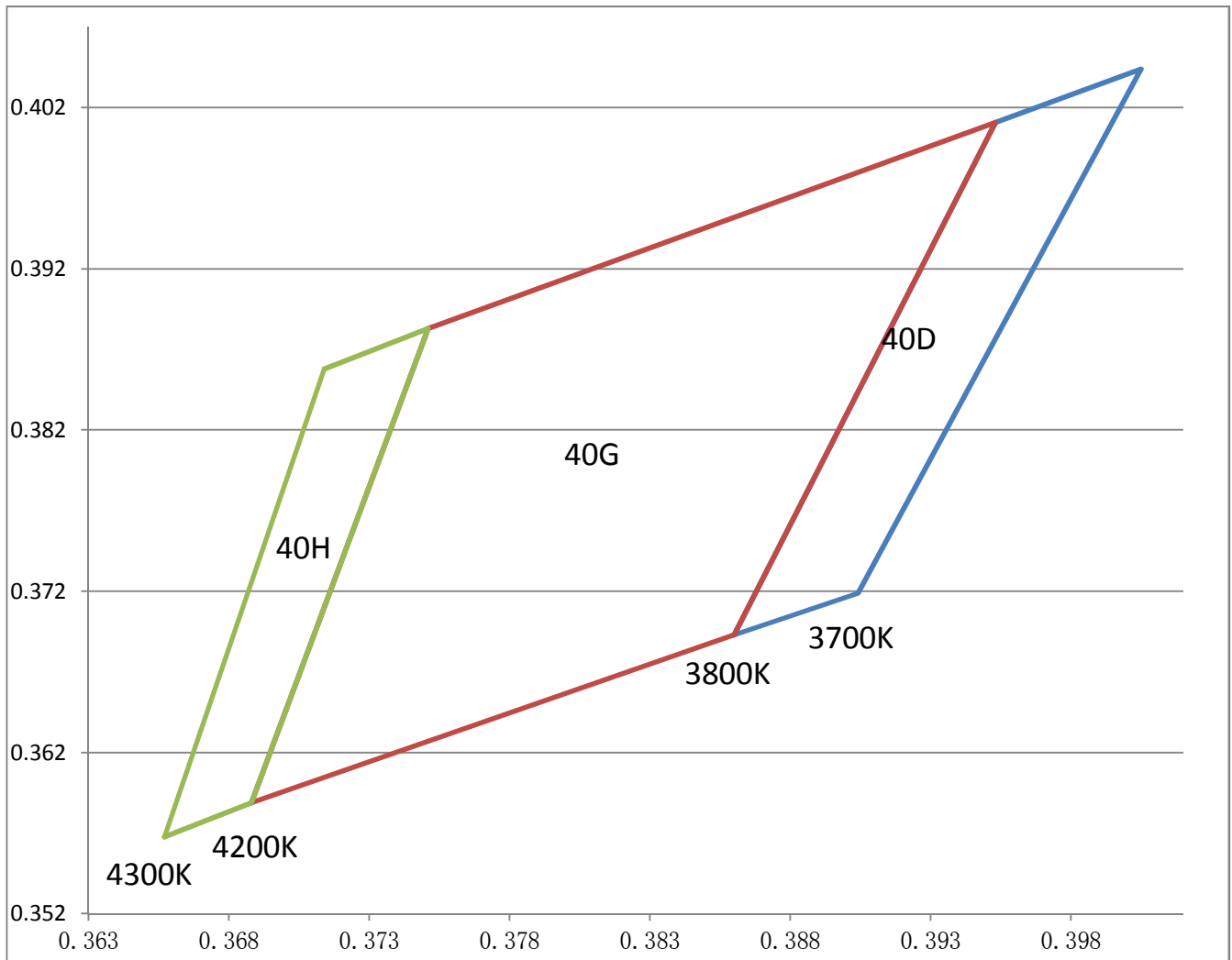

Typical optical characteristics curves

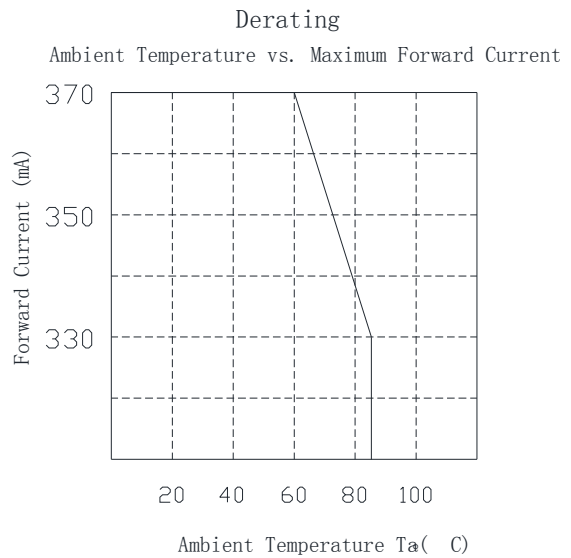
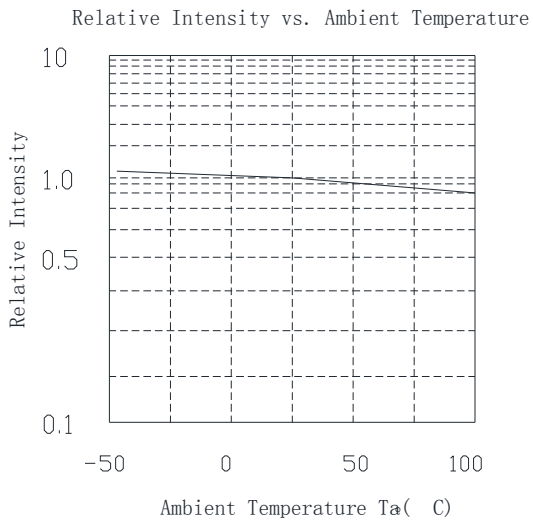
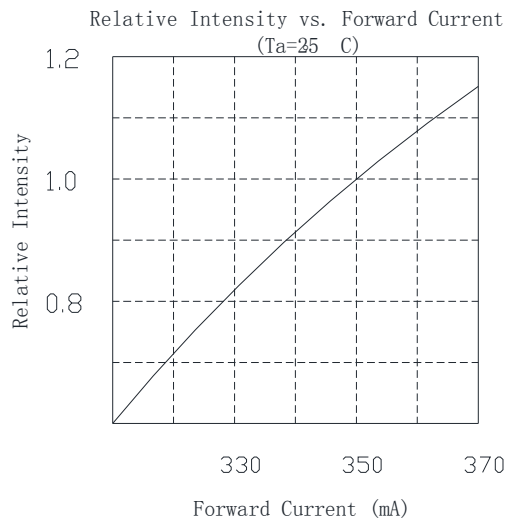
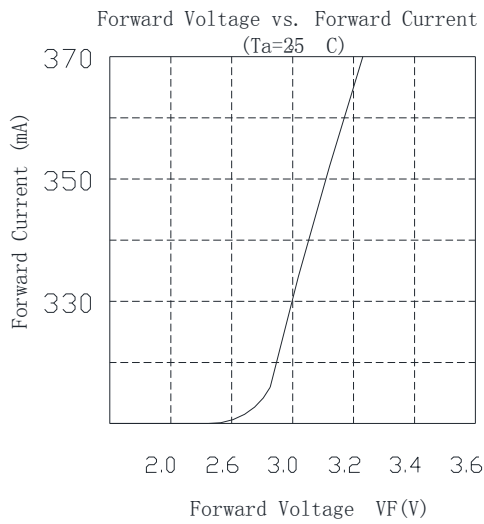
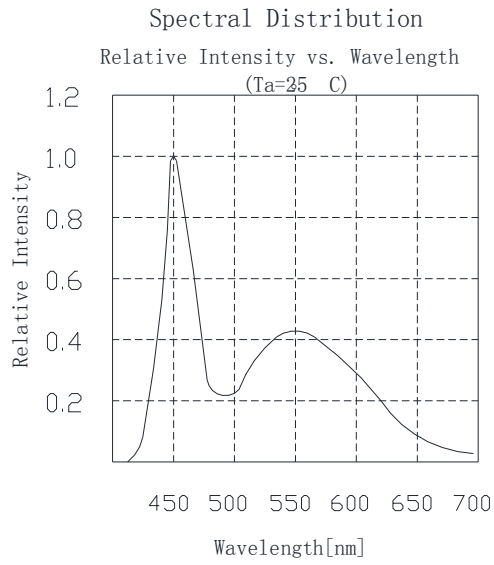

Reflow profile

■ Soldering condition

- Recommended soldering conditions

Reflow Soldering		Hand Soldering	
Pre-heat	160~180°C	Temperature	300°C Max.
Pre-heat time	120 seconds Max.	Soldering time	3 second Max. (one time only)
Peak temperature	260°C Max.		
Soldering time	10 seconds Max.		
Condition	Refer to Temperature-profile		

- After reflow soldering rapid cooling should be avoided

■ Temperature-profile (Surface of circuit board)

Use the following conditions shown in the figure.

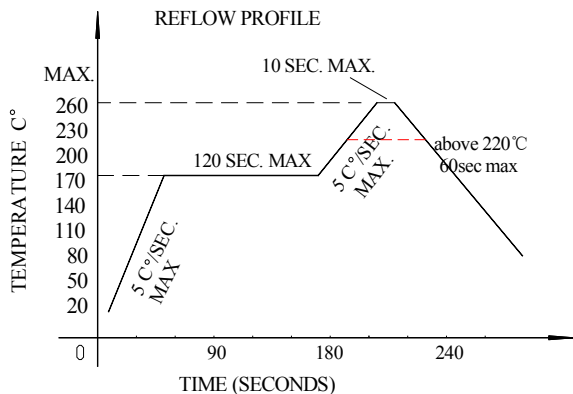

1. Reflow soldering should not be done more than two times
2. When soldering, do not put stress on the LEDs during heating

■ Soldering iron

1. When hand soldering, keep the temperature of the iron under 300°C, and at that temperature keep the time under 3 sec.
2. The hand soldering should be done only a time
3. The basic spec is ≤ 5 sec. when the temperature of 260°C, do not contact the resin when hand soldering

■ Rework

1. Customer must finish rework within 5 sec under 260°C
2. The head of iron can not touch the resin
3. Twin-head type is preferred.

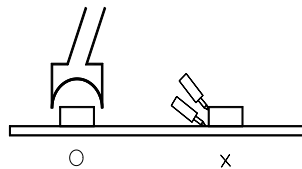

■ CAUTIONS

The encapsulated material of the LEDs is silicone. Therefore the LEDs have a soft surface on the top of package. The pressure to the top surface will be influence to the reliability of the LEDs. Precautions should be taken to avoid the strong pressure on the encapsulated part. So when using the picking up nozzle, the pressure on the silicone resin should be proper.

Reliability

(1) TEST ITEMS AND RESULTS

Type	Test Item	Test Conditions	Note	Number of Damaged
Environmental Sequence	Resistance to Soldering Heat(Reflow Soldering)	Tsld=260°C,10sec	2 times	0/22
	Temperature Cycle	-40°C 30min ↑↓5min 100°C 30min	100cycle	0/22
	Thermal Shock	-40°C 15min ↑↓ 100°C 15min	100 cycle	0/22
	High Temperature Storage	T _a =100°C	1000 hrs	0/22
	Low Temperature Storage	T _a =-40°C	1000 hrs	0/22
Operation Sequence	Life Test	T _a =25°C I _F =350mA	1000 hrs	0/22
	High Humidity Heat Life Test	60°C RH=85% I _F =350mA	500 hrs	0/22

(2) CRITERIA FOR JUDGING THE DAMAGE

Item	Symbol	Test Conditions	Criteria for Judgement	
			Min.	Max.
Forward Voltage	VF	IF=350mA	—	U.S.L*)×1.1
Reverse Current	IR	VR=5V	—	U.S.L*)×2.0
Luminous Intensity	IV	IF=350mA	L.S.L**)×0.7	—

U.S.L.: Upper Standard Level

L.S.L.: Lower Standard Level

Packaging Specifications

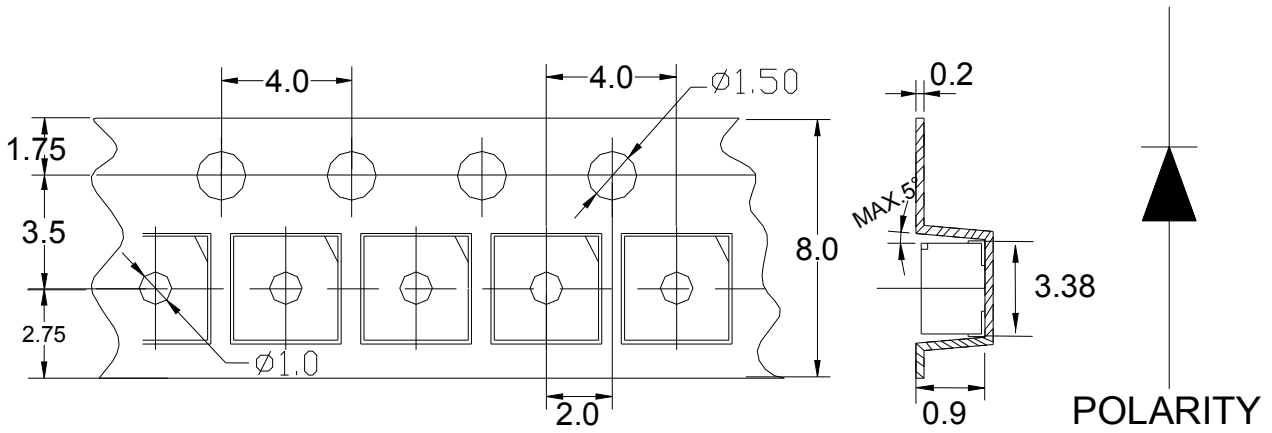

Packaging specifications

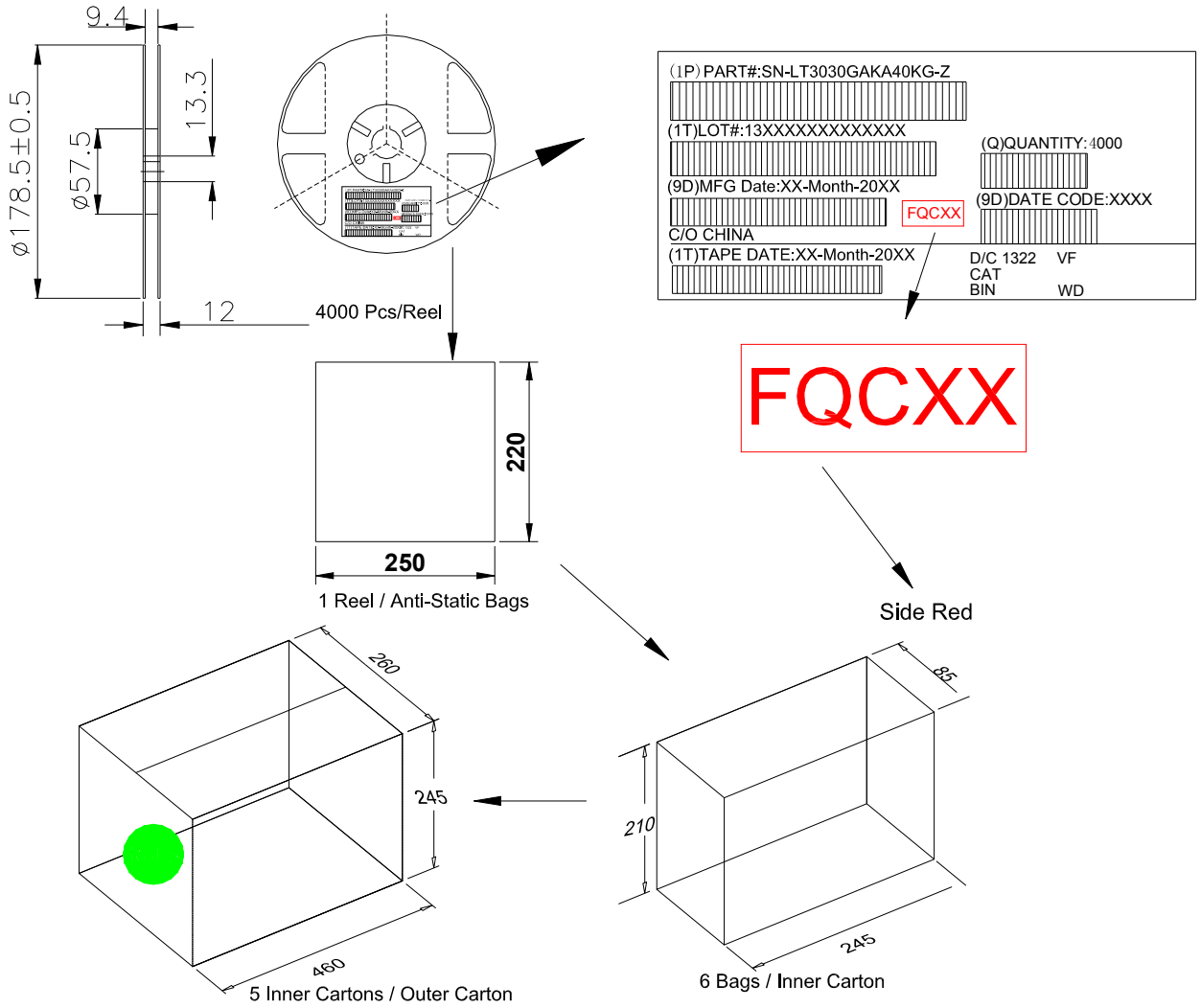

CAUTIONS

Storage conditions

Before opening the package:

The LEDs should be kept at 30 °C or less and 70%RH or less. The LEDs should be used within a year. When storing the LEDs, moisture proof packaging with absorbent material (silica gel) is recommended.

After opening the package:

The LEDs should be kept at 30 °C or less and 50%RH or less. The LEDs should be soldered within 24 hours (1days) after opening the package. If unused LEDs remain, they should be stored in moisture proof packages, such as sealed containers with packages of moisture absorbent material (silica gel). It is also recommended to return the LEDs to the original moisture proof bag and to reseal the moisture proof bag again

Revision History		
Date	Revision History	Prepared
2017.8.22	New Version	