

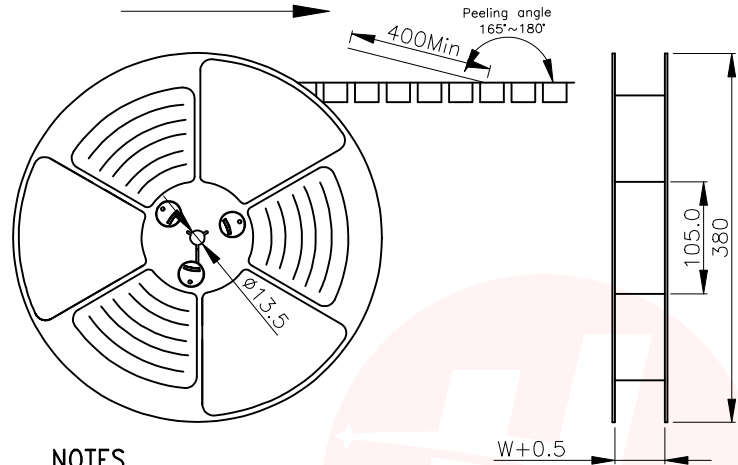

REV.	ECN NO OR DESCRIPTION	REVISED	DATE

出料方向

PULL OUT DIRECTEON



NOTES

1. 帶子引導長度
LEAD TAPE LENGTH

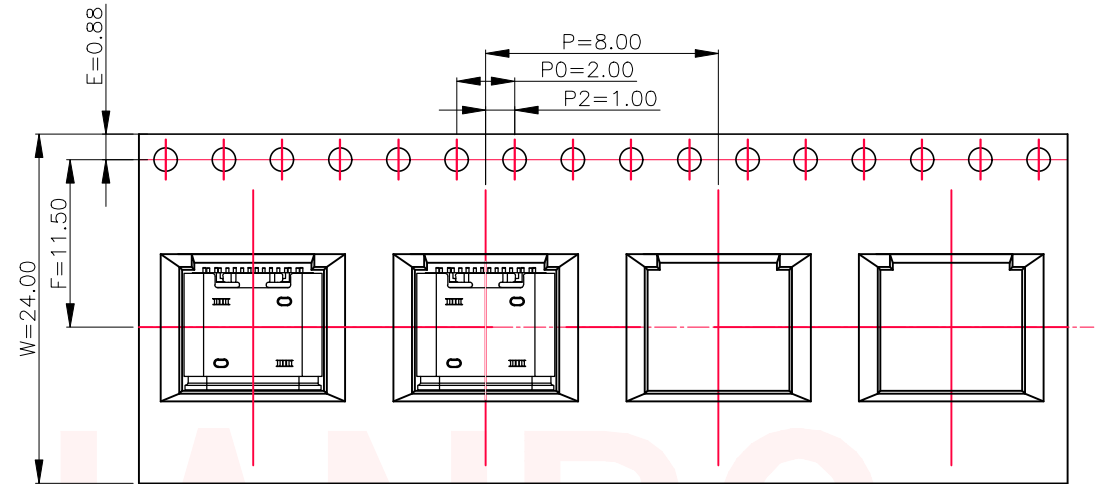
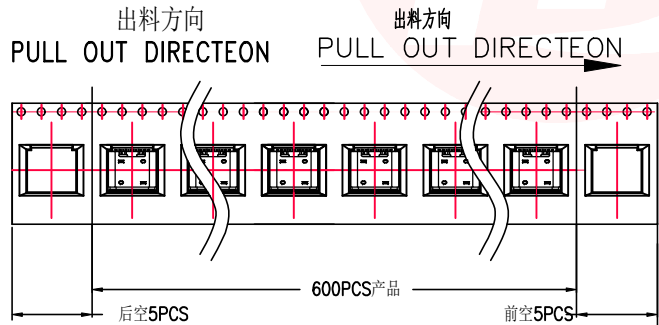

TAPE & REEL 7 PCS

1 REEL
= 600 PCS

BOX

DIMENSIONS:
39.5X39.5X20

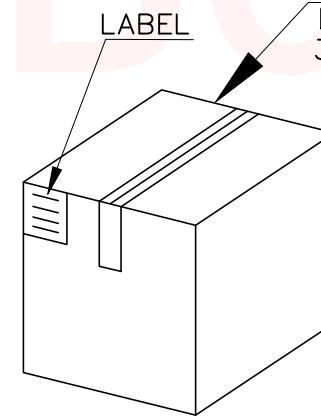
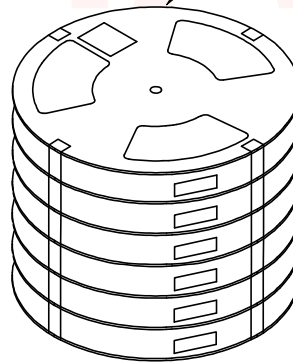

1 CARTON
= 6 REELS
= 3600 PCS

2. 上帶 剝離力為: 0.1~1.3N(10.2gf~130gf)

PEELING OFF FORCE OF TOP TAPE: 0.1~1.3N(10.2gf~130gf)

出貨'運輸過程中一定注意:

THIS REQUIREMENT SHOULD BE APPLIED AT SHIPMENT:

卷帶在運輸過程中不能散開

PEELING OFF SHOULD NOT BE ALLOWED DURING TRANSPORTATION

UNLESS OTHERWISE SPECIFIED TOLERANCES		东莞市汉博电子科技有限公司 DONGGUAN HANBO TECHNOLOGY CO., LTD			
DECIMALS:	ANGLES:	TITLE	USB TYPE C 16PIN 板上墊高1.9mm (CH=3.5)		
X : ±0.30	X : ±2°	DWN	xiong	PART NO. MC-108-DG19	
X.X : ±0.20	X.X : ±1°	CHKD	lee	SCALE: 1:1	UNIT: mm
X.XX : ±0.10		APVD	wang	SIZE: A4	SHEET: 10F 1
REV: A4					
CUSTOMER COPY					