

GENERAL SPECIFICATIONS (电气特性)

1. Holder type: (型号)	3225/SMD
2. Normal Frequency: (标称频率)	25.00000MHz
3. Oscillation Mode: (振动模式)	<input checked="" type="checkbox"/> Fundamental <input type="checkbox"/> 3rd
4. Load Capacitance(CL): (负载电容)	12 PF
5. Frequency Tolerance 25±3°C: (频率偏差 25±3°C)	±10 PPM
6. Stability Over Temperature Range: (工作温度频率偏差)	±10 PPM (-20°C to +75°C)
7. Effective Series Resistance: (等效电阻)	≤ 30 Ω
8. Shunt Capacitance(C0): (静态电容)	≤ 5 PF
9. Typical drive level: (激励功率)	100 uW TYP.
10. Operation Temperature Range: (工作温度范围)	-40°C to +85°C
11. Storage Temperature: (存储温度)	-40°C to +85°C
12. Insulation Resistance: (绝缘阻抗)	≥500 MΩ at DC 100V
13. Aging: (老化率)	±3 PPM/Year
14. Leak (检漏)	1×10 ⁻⁷ Torr.1/sec Max
15. Test circuit (测试仪器)	S&A 250B Pi-Network Crystal Measurement System

Remark (备注):

晶振最佳储存条件: 温度: 25±5°C, 湿度: <70%。
密封包装, 切勿挤压, 小心跌落。

DIMENSIONS SPECIFICATIONS (外形尺寸)

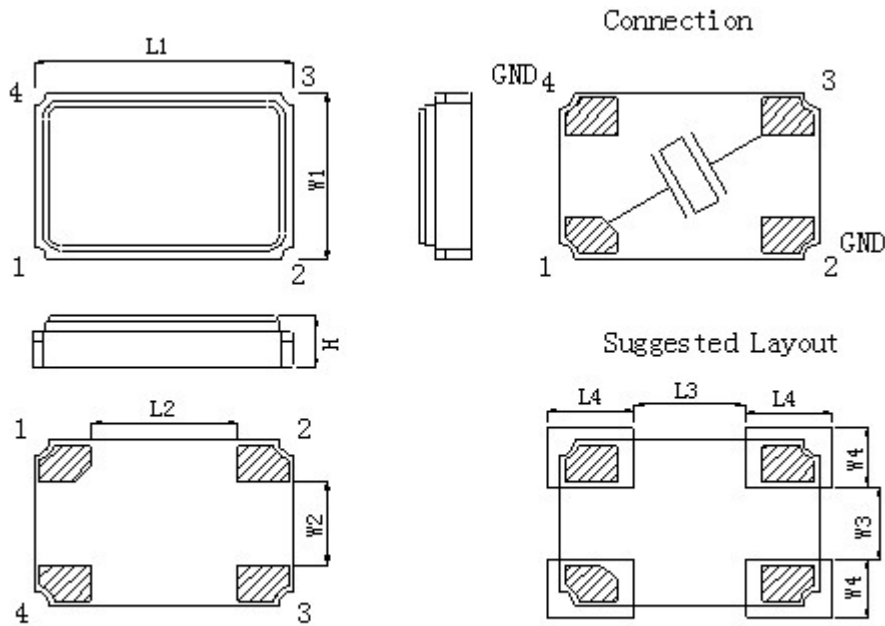

Marking #2and#4 are connected to metal cap of top

型号	外形尺寸(±0.15mm)								
	L1	L2	L3	L4	W1	W2	W3	W4	H
5032	5.0	3.0	1.2	1.7	3.2	0.9	0.7	1.5	0.9
3225	3.2	1.3	0.8	1.4	2.5	0.7	0.5	1.2	0.7
2520	2.5	0.9	0.6	1.1	2.0	0.6	0.4	1.0	0.5
2016	2.0	0.7	0.5	0.9	1.6	0.5	0.3	0.8	0.5

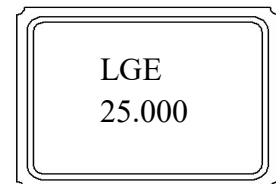

STRUCTURE DIAGRAM (结构图示)

