

Specification of MEMS Microphone

RoHS Compliance & Halogen Free

LinkMems P/N: LMA3729T381-OY1S

Designed by	Checked by	Approved by
Thomas	Hary	Jack

Customer Approval

Approved by: _____



Contents

1. Introduction	3
2. Electrical Characteristics	3
3. Frequency Response Curve	4
3.1. Frequency Response Curve	4
4. Test Setup	4
5. Measurement Circuit	4
6. Mechanical Characteristics	5
6.1. Weight	5
6.2. Appearance Drawing	5
7. Application	6
7.1. Pickup Tool Pick Location & PCB Solder Pad Layout	6
7.2. Recommended Reflow Process Condition	6
7.3. Storage Condition	7
8. Packaging	7
8.1. Tape & Reel Specification	7
8.2. Packaging Information	8
9. Reliability Test	9

MEMS Microphone

1. Introduction

The LMA3729T MEMS Microphones are integrated with specialized Pre-amplification ASIC to provide high sensitivity, high SNR output from a capacitive audio sensor. It's packaged for surface mounting and high temperature reflow assembly.

2. Electrical Characteristics

Parameter	Absolute Maximum Rating	Unit
Voltage Range of VDD to Ground	-0.3 to +3.9	V
Voltage Range of OUT to Ground	-0.3 to +3.9	V
Input Current to Any Pin	±5	mA
Temperature Range	-40 to +100	°C

Test Condition: $V_{DD}=2.0V$, $23\pm 2^{\circ}C$, $55\pm 20\%R.H.$, unless otherwise specified.

Specification	Symbol	Test Conditions	Min.	Typ.	Max.	Unit
Directivity			Omni-directional			
Sensitivity Range	S	94dB SPL @1kHz	-39	-38	-37	dB
Output Impedance	Z_{out}	94dB SPL @1kHz			300	Ω
Current Consumption	I				250	μA
S/N Ratio	SNR	94dB SPL @1kHz A-Weighted		65		dB(A)
Operating Voltage	V_{DD}		1.5	2.0	3.6	V
Total Harmonic Distortion	THD	94dB SPL @1kHz		0.15		%
Acoustic Overload Point	AOP	10% THD @1kHz		125		dB SPL
Power Supply Rejection Ratio	PSRR	200mVpp Sine wave@1kHz, $V_{DD}=2V$		60		dB
Power Supply Rejection	PSR	100mVpp Square wave@217Hz, $V_{DD}=2V$, A-weighted		-90		dBV

3. Response Curve

3.1 Frequency Response Curve

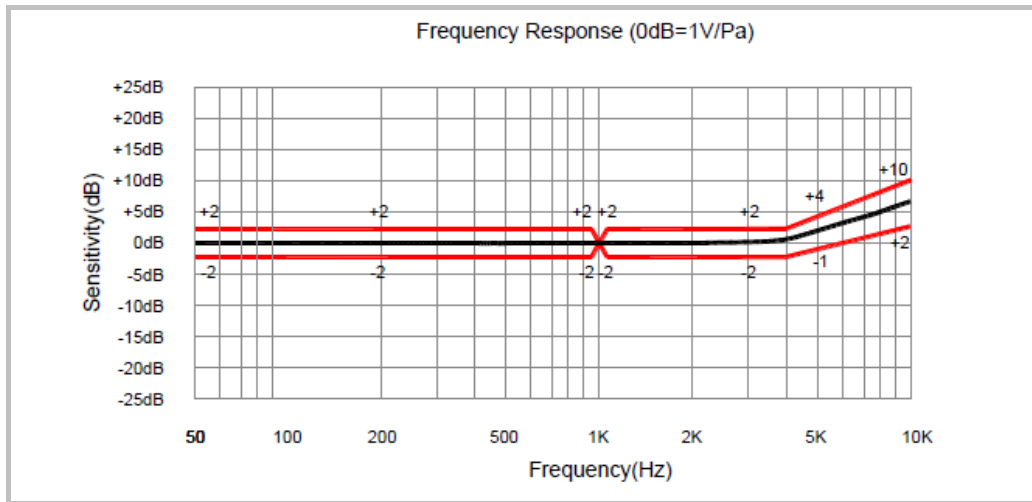

4. Test Setup (Sensitivity Test in Anechoic Room)

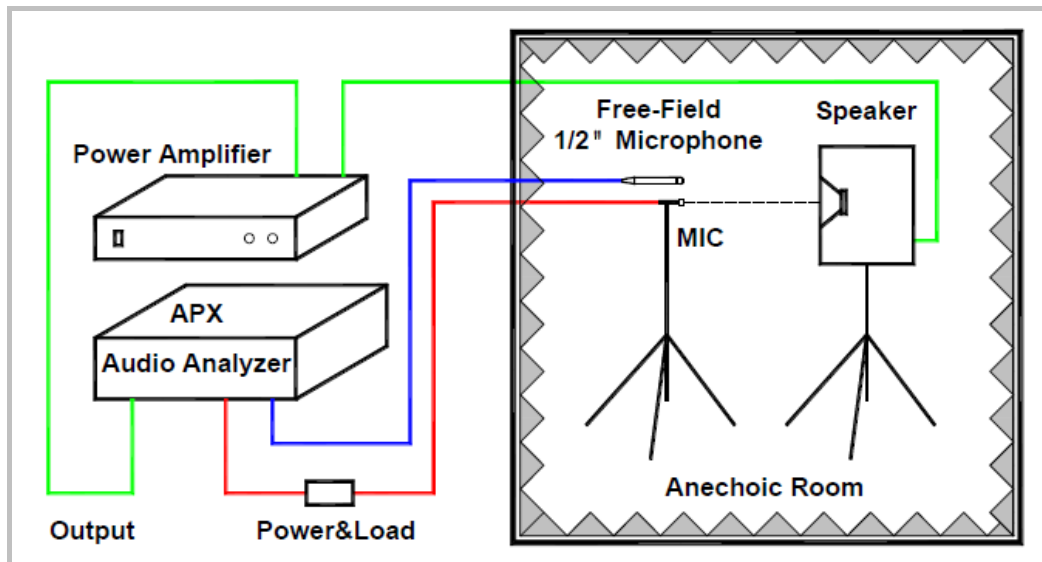

5. Measurement Circuit

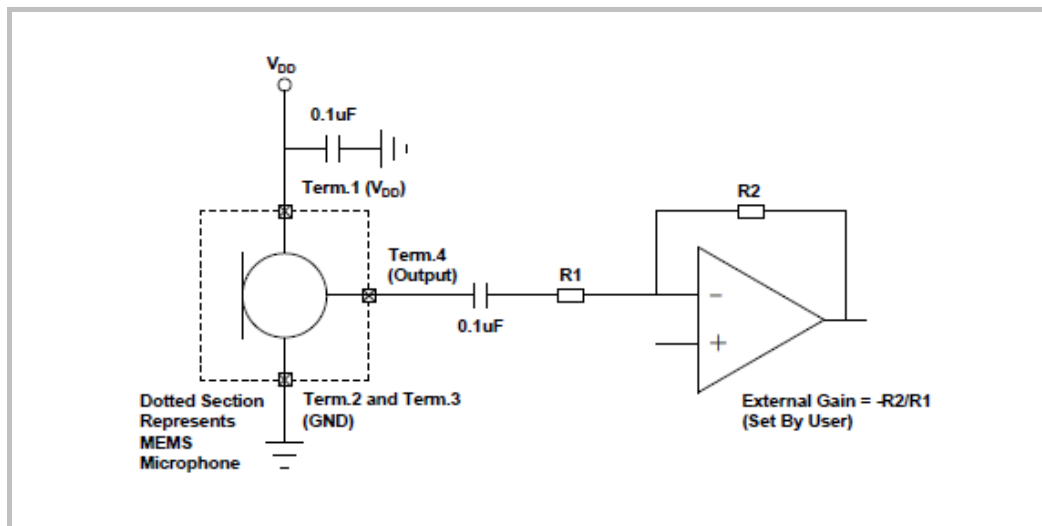

6. Mechanical Characteristics

6.1 Weight: Less than 0.03g

6.2 Appearance Drawing(unit: mm)

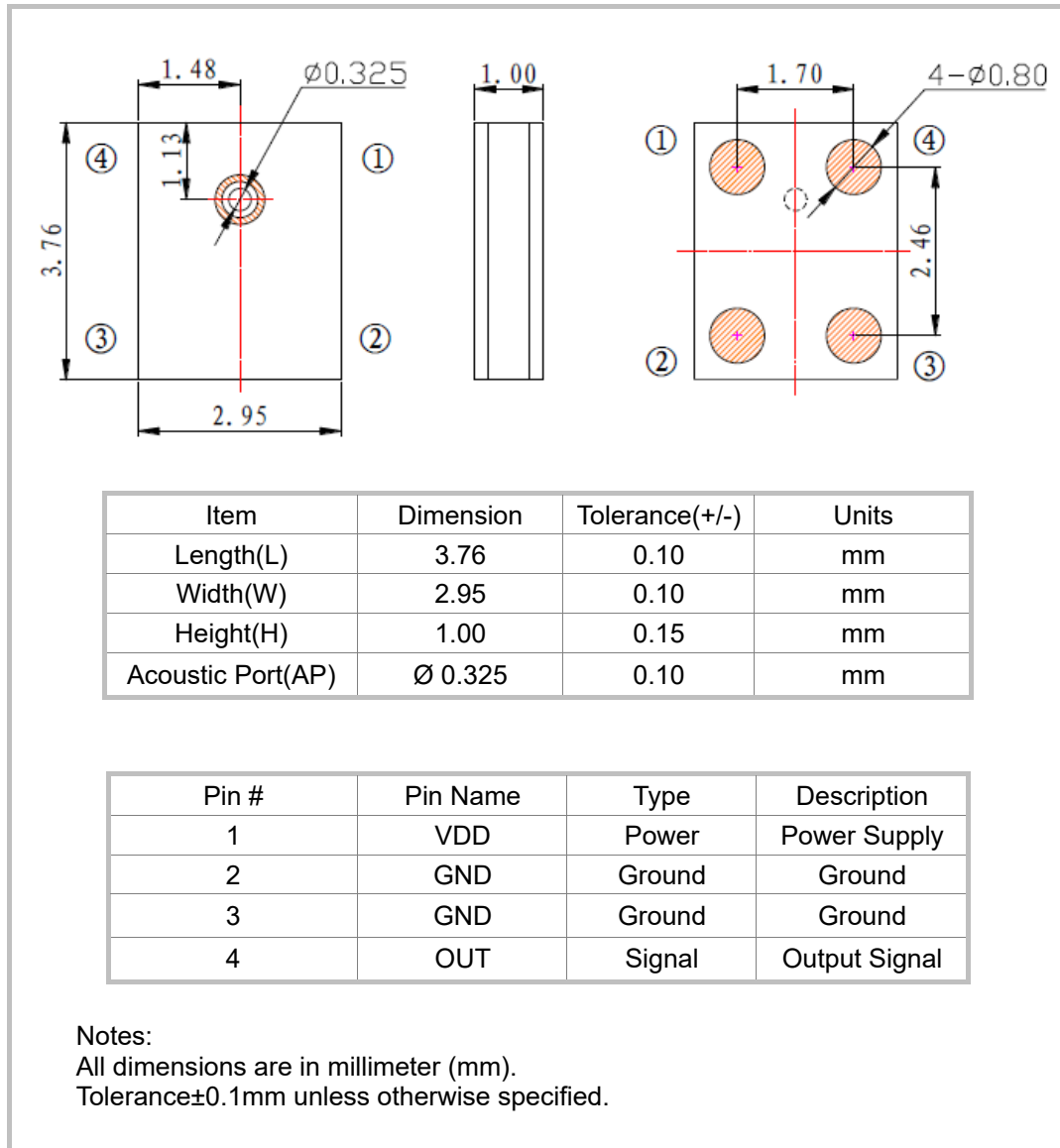

7. Application

7.1 Pickup Tool Pick Location & PCB Solder Pad Layout

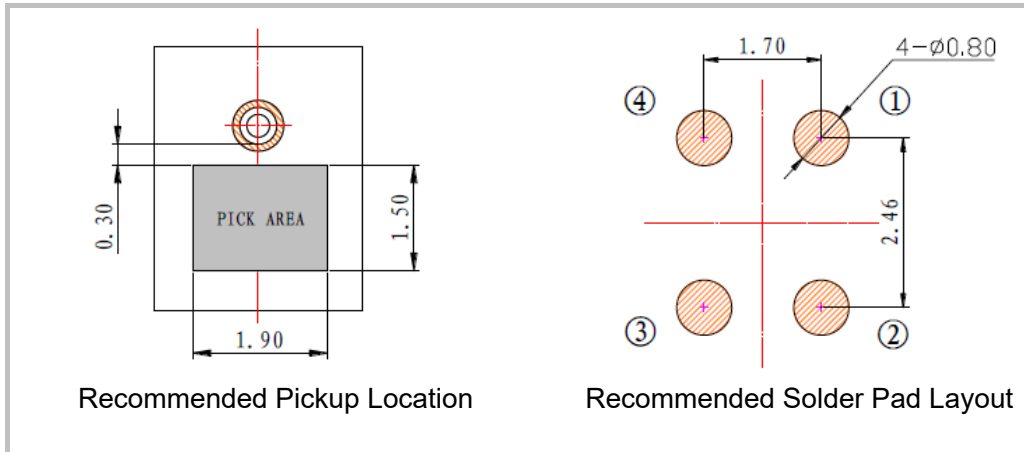

7.2 Recommended Reflow Process Condition

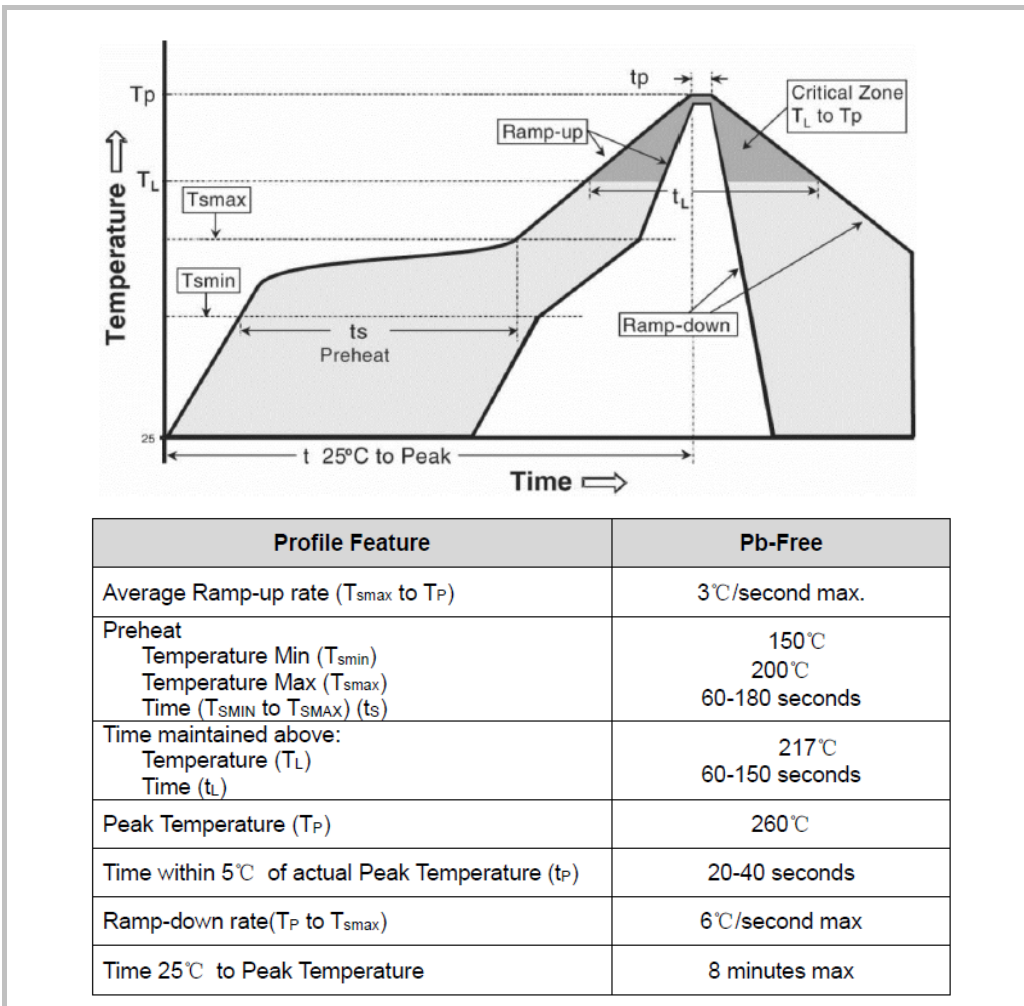

Important Notes

1. Pulling vacuum over acoustical hole of the microphone is not allowed, because the device can be damaged by vacuum.
2. Wash the board after reflow process is not allowed, because board washing and cleaning agents can damage the device. Device should not be exposed to ultrasonic processing or cleaning.
3. Recommended number of reflow is no more than 3 times.

7.3 Storage Condition

- 7.3.1 Storage temperature range: -40~+100°C, and humidity is less than 75%.
- 7.3.2 Operating temperature range: -40~+100°C.
- 7.3.3 MSL (moisture sensitivity Level) is Class 1.

8. Packaging

8.1 Tape & Reel Specification

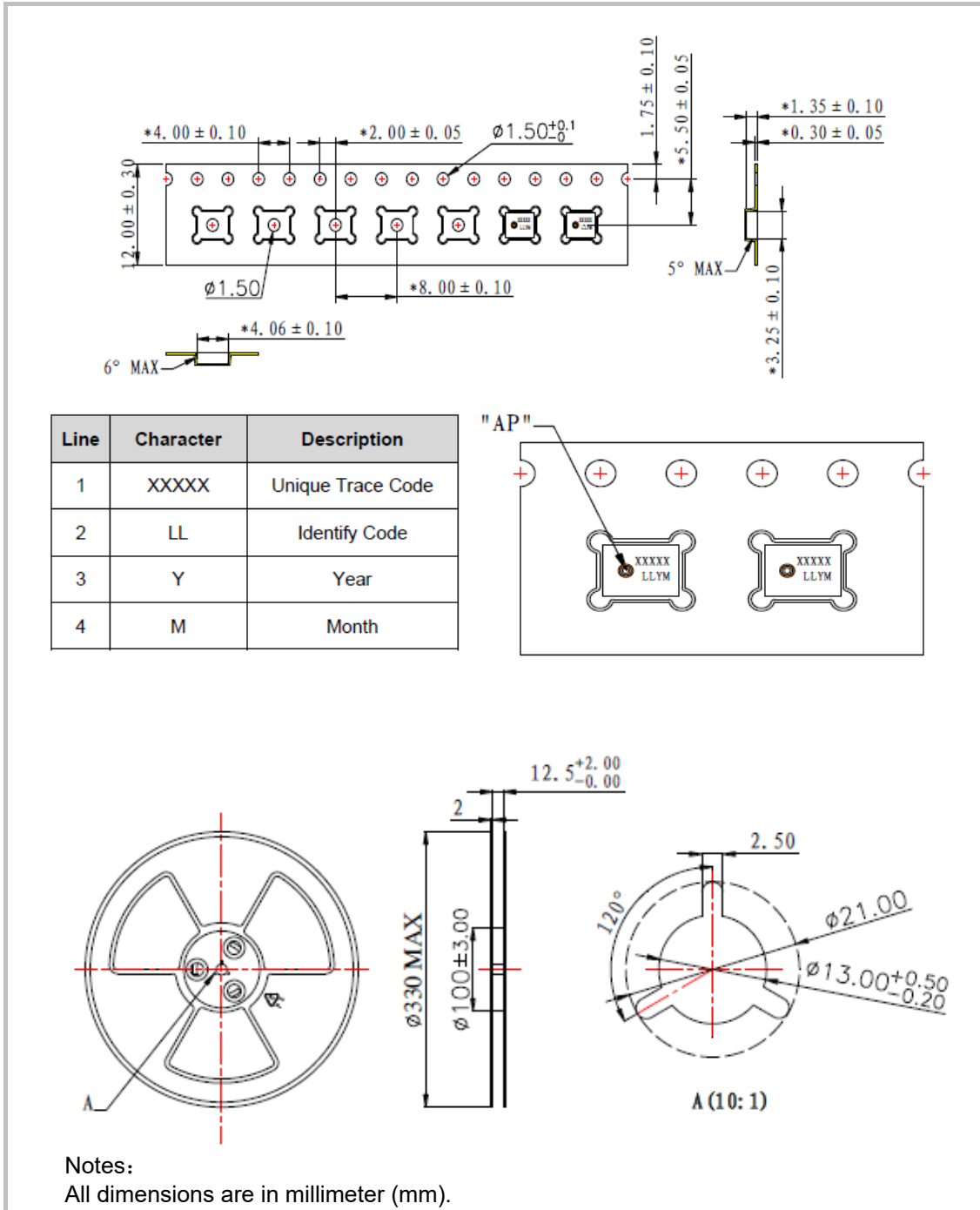

8.2 Packaging Information

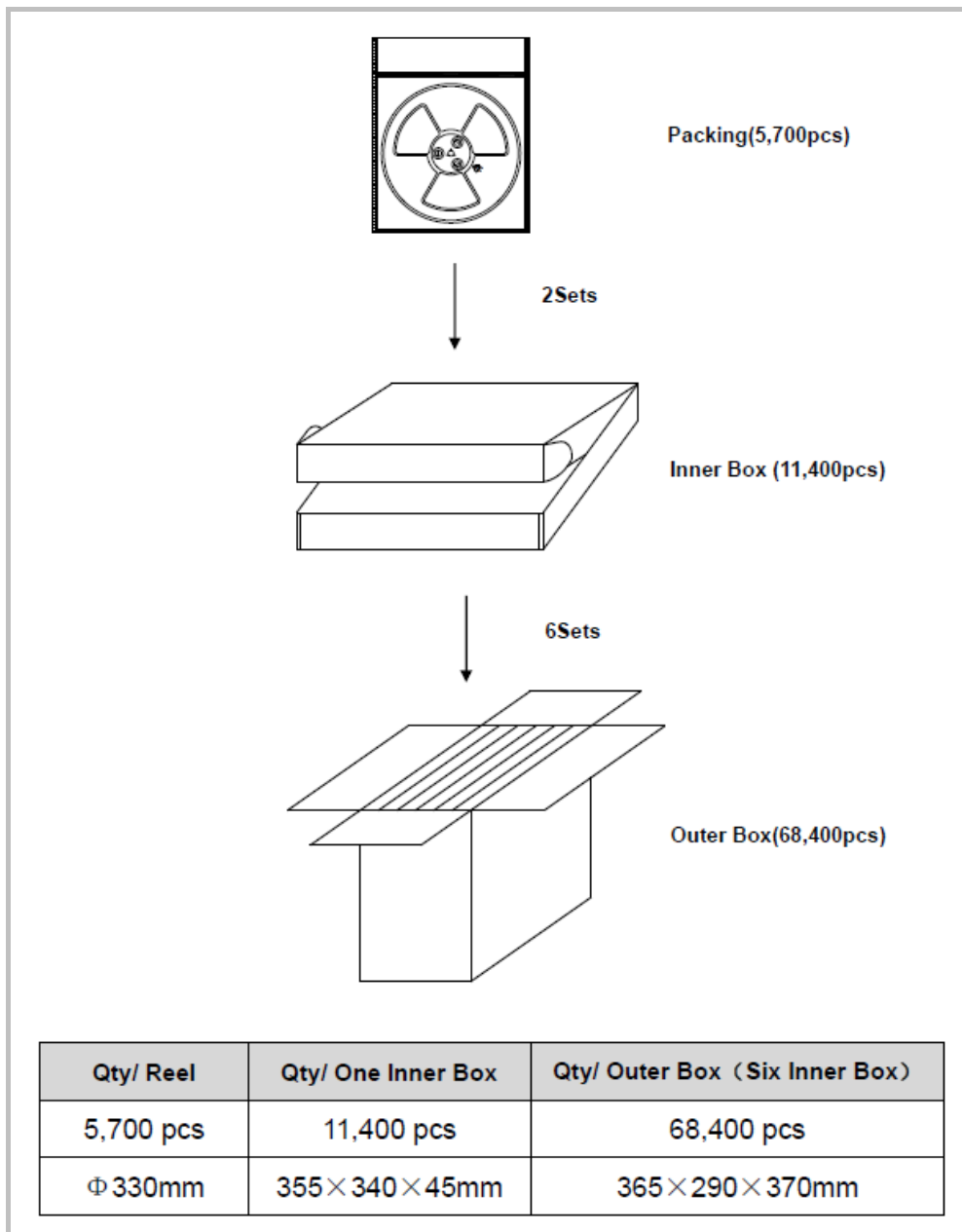

9. Reliability Test

The samples should be placed in the room with $23\pm 2^{\circ}\text{C}$, $55\pm 10\%\text{R.H.}$ for 2 hours at least before final measurement, unless otherwise specified.

Item	Detail	Standard
Thermal Shock	100 cycles of air-air thermal shock from -40°C to $+105^{\circ}\text{C}$ with 15 minute soaks.	± 3 dB
High Temperature Storage	$+105^{\circ}\text{C}$ environment for 240 hours.	± 3 dB
Low Temperature Storage	-40°C environment for 240 hours.	± 3 dB
High Temperature Test	$+105^{\circ}\text{C}$ environment while under bias for 240 hours.	± 3 dB
Low Temperature Test	-40°C environment while under bias for 240 hours.	± 3 dB
Humidity Test	$+85^{\circ}\text{C}/85\%$ R.H. environment while under bias for 240 hours.	± 3 dB
Vibration Test	16 minutes in each X, Y, Z axis from 20 to 2,000 Hz with peak acceleration of 20G.	± 3 dB
Drop Test	1.5-meter height onto a concrete surface each time at three directions in state of packaging.	± 3 dB
Reflow Test	5 reflow cycles with peak temperature of $+260^{\circ}\text{C}$.	± 3 dB

