

## - 规格书 -

产品型号: SMI - 10HDG

产品名称: 滑动开关

# SM SWITCH CO.,LTD

Add : 江苏省无锡市新吴区弘毅路8号金帛座706室  
韩国京畿道富川市三鹊路22号富川科技园103-506栋  
TEL : +86-510-8591-9217  
E-mail : SMSWITCH@SIMAOKJ.COM  
Web : WWW.SIMAOKJ.CN

MARK	DATE	REMARKS
△		
△		

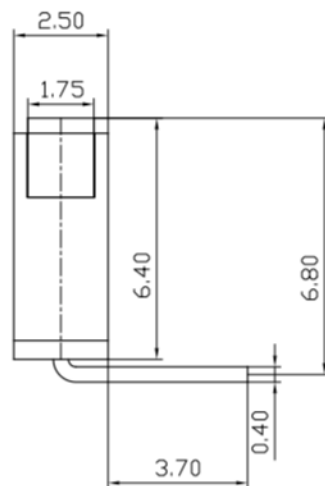
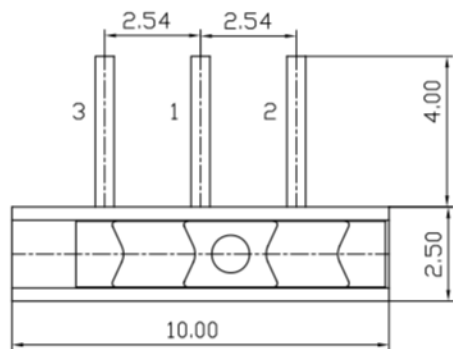

CIRCUIT

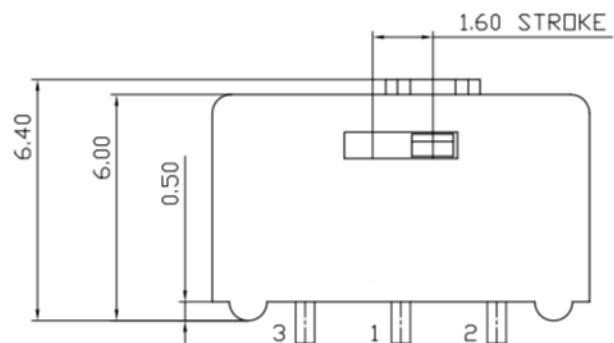
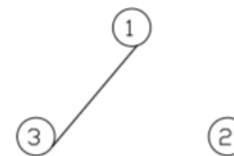

P.C.B DIMENSION

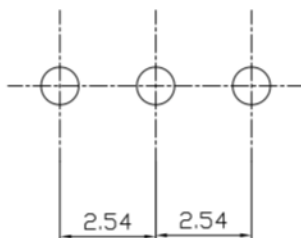

APPD	CHKD	D'SGD	TITLE.	MINI SLIDE SWITCH	
Y.D WANG	J.S KIM	H.S LEE	MODEL NO.	SMI-10HDG	REV   A
			SM SWITCH CO., LTD.		



# GENERAL SPECIFICATION

Rev. A  
P:1/1

## SMI SERIES

### 1. Electrical Characteristics.

- 1-1. Rating : AC, DC 12V 0.5A ~ 24V 0.3A. (Minimum current : 1mA)
- 1-2. Contact Resistance : Max 30mΩ
- 1-3. Insulation Resistance : Min 10,000MΩ, at dc 500V
- 1-4. Withstanding Voltage : 1min at AC 500V

### 2. Mechanical Characteristics.

- 2-1. operating Force : Max 800gf
- 2-2. Angle of Lever Throw
- 2-3. Insulator
  - 2-3-1. Case : Glass Fiber Reinforce Polyamide (UL94 V-0)
  - 2-3-2. Slide : Glass Fiber Reinforce Polyamide (UL94 V-0)
  - 2-3-3. Spring : Stainless Steel
  - 2-3-4. Contact : Brass
  - 2-3-5. Terminal : Brass
- 2-4. Contact & Terminal : Nickel(Ni 1.0μm) Gold Plate(Au 0.03μm)

### 3. Life Test.

- 3-1. Test Condition : Operations at a rate of 15-20Cycle 1minute
  - 3-1-1. with load : 1,000 Cycles
  - 3-1-2. without load : 1,000 Cycles
- 3-2. Operating Force : With + 10%, -40% of Initial Value
- 3-3. Contact Resistance : Max 30mΩ

### 4. Environmental Characteristics.

- 4-1. Operating Temperature : -40°C to + 85°C
- 4-2. Storage Temperature : -40°C to + 85°C
- 4-3. Humidity Test
  - 4-3-1. Test Conditions : Measured 1Hour After Exposure to Ambient after 96Hour Exposure at 40±2°C, 90-95%R.H
  - 4-3-2. Insulation Resistance : Min 10,000MΩ, at DC 500V
  - 4-3-3. Withstanding Voltage : 1min at AC 500V
- 4-4. Saline Spray Test : 24 hours

### 5. Solder Conditions

- 5-1. Within 5 sec. at 270°C

### 6. RoHS Compliant