

RoHS

MAPX

MODIFICATION

DRW

DATE

NOTES:

- MATERIAL: SEE "TABLE 1";
- FINISH: SEE "TABLE 1";
- ELECTRICAL :
 - CONTACT CURRENT RATING :
3A (VBUS PIN 1.5A/PIN MAX),
3A (GND PIN 1.25A/PIN MAX), 0.25A/PIN (OTHER PIN).
 - INSULATION RESISTANCE :
100 MEGAOHMS MIN. AT 250VDC.
 - DIELECTRIC WITHSTANDING VOLTAGE :
100VAC MIN.
 - LOW LEVEL CONTACT RESISTANCE :
INITIAL 40mΩ MAX.
AFTER 50mΩ MAX.
- MECHANICAL CHARACTERISTICS :
 - MATING FORCE: 5*20N.;
 - UNMATING FORCE: 6~20N (INITIAL),
6~20N (AFTER 10000 CYCLES);
 - DURABILITY : 10, 000 MATING CYCLES.
 - OPERATING TEMPERATURE :-40° C TO +80° C

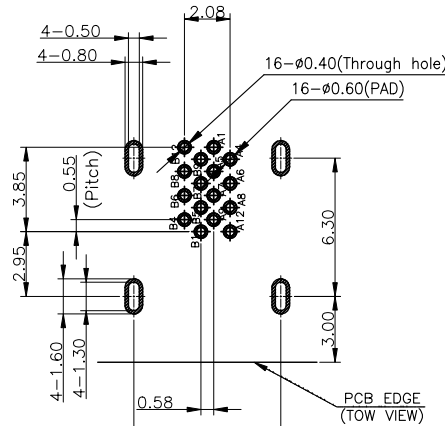
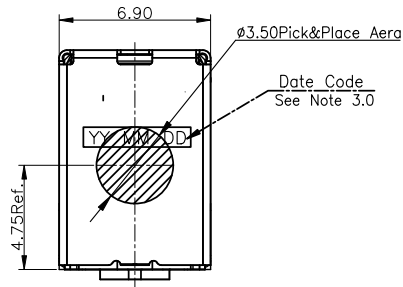

RECOMMENDED PCB LAYOUT (THICKNESS: 0.80MM)
PWB TOLERANCE: ±0.05

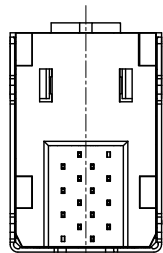
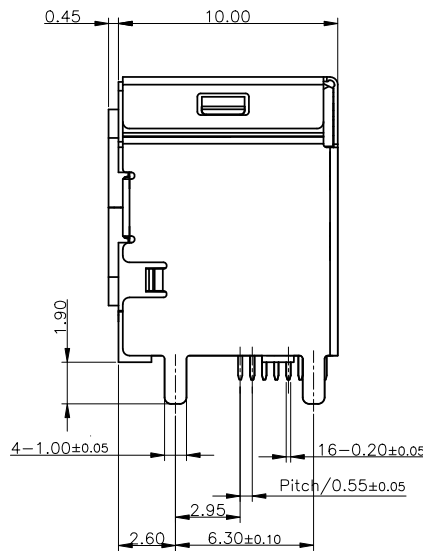
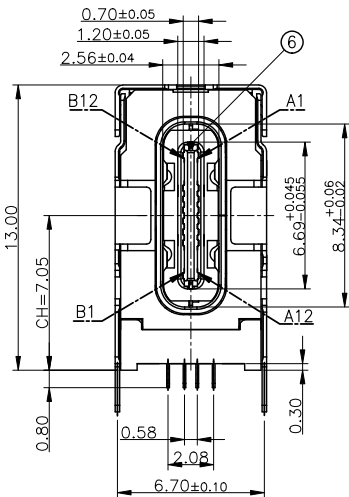

ITEM	DESCRIPTION	MATERIAL	FINISH	Q'TY	Signal Name	Signal Name
⑥	MID PLATE	STAINLESS STEEL	OVER ALL 0.76MICRON (30u")MIN NICKEL PLATING	1	A1 GND	B12 GND
⑤	OUTER SHELL	STAINLESS STEEL	OVER ALL 0.76MICRON (30u")MIN NICKEL PLATING	1	A2 SSTXp1	B11 SSRXp1
④	MAIN SHELL	STAINLESS STEEL	OVER ALL 0.76MICRON (30u")MIN NICKEL PLATING	1	A3 SSTXn1	B10 SSRXn1
③	TERMINAL	COPPER ALLOY	GOLD PLATING 0.076MICRON (3u")MIN ON CONTACT AREA GOLD PLATING FLASH ON SOLDER TAIL AREA, ALL OVER 1.27 MICRON(50u") MIN.NICKEL	16	A4 VBUS	B9 VBUS
②	IN-MOLDING	HIGH TEMP. THERMOPLASTIC	GLASS FILLED (OR EQUAL),UL 94V-0,BLACK,NO RECYCLED RESIN.	1	A5 CC1	B8 SBU2
①	HOUSING	HIGH TEMP. THERMOPLASTIC	GLASS FILLED (OR EQUAL),UL 94V-0,BLACK,NO RECYCLED RESIN.	1	A6 Dp1	B7 Dn2
					A7 Dn1	B6 Dp2
					A8 SBU1	B5 CC2
					A9 VBUS	B4 VBUS
					A10 SSRXn2	B3 SSTXn2
					A11 SSRXp2	B2 SSTXp2
					A12 GND	B1 GND

<p>产品图 PRODUCT CHART DWG 公差一览表 TOLERANCE UNLESS OTHERWISE</p>				<p>深圳市精拓金电子有限公司 Shenzhen Jing Tuo Jin Electronics Co., Ltd.</p>						
X.	±0.25	X.	±5°	单位 UNITS	MM	制图 DRAWING	林属升	制图料号 PRODUCT PART NO.	918-518K2023D50005	
.X	±0.20	.X	±2°	比例 SCALE	1:1	审核 CHKD	郭治富	产品名称 PRODUCT NO.	TYPE-C3.1侧插母座全包10.0 13.0四脚插板 不锈钢LCP本色,16P	
.XX	±0.15	.XX	±1°	日期 DATE	2020-05-22	核准 APPD	黄国荣	角法 VIEW	版本 VER	AO
.XXX	±0.10	.XXX	±0.5°							

RoHS

MAPX

MODIFICATION

DRW

DATE

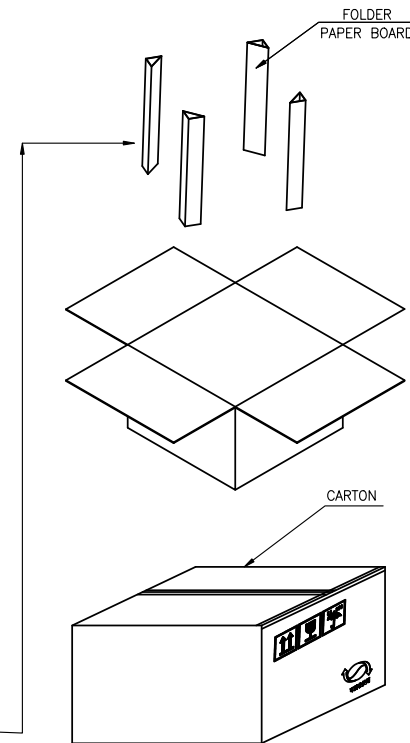
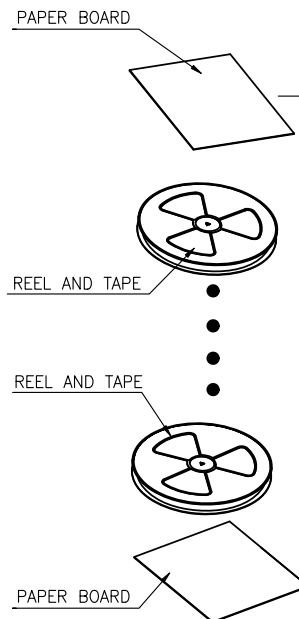
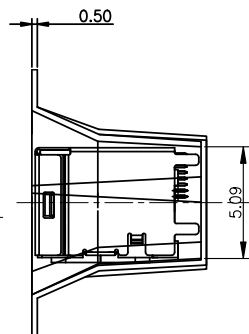
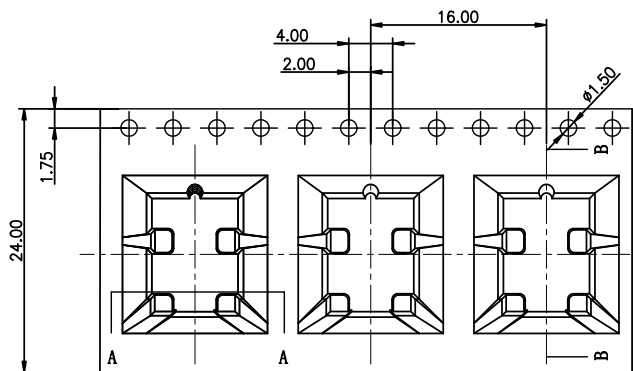
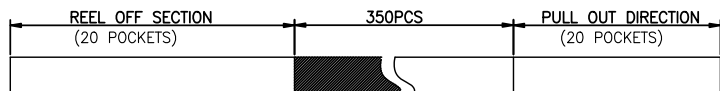

← PRODUCT PACKAGING DIRECTION
CUSTOMER TO USE DIRECTION →

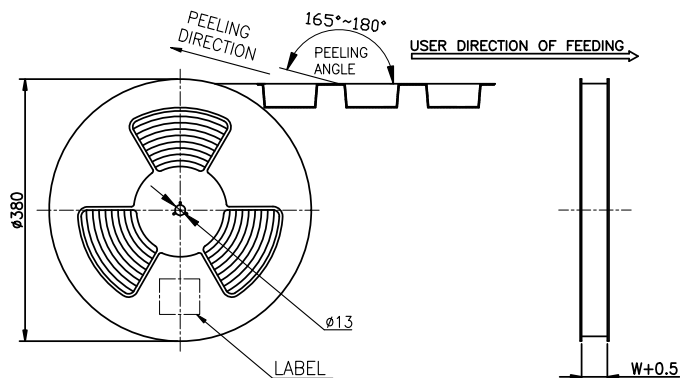

CONN. PART NO.	CONN. QTY./REEL	REEL QTY./CARTON	CONN. QTY./CARTON
01013-UCAF004-X	350	8	2800 PCS

产品图 PRODUCT CHART DWG 公差一览表 TOLERANCE UNLESS OTHERWISE		深圳市精拓金电子有限公司 Shenzhen Jing Tuo Jin Electronics Co., Ltd.							
X.	±0.25	X.	±5°	单位	MM	制图	林属升	制图料号	918-518K2023D50005
.X	±0.20	.X	±2°	比例	1:1	审核	郭治富	产品名称	TYPE-C3.1侧插母座全包10.0 13.0四脚插板
.XX	±0.15	.XX	±1°	日期	2020-05-22	核准	黄国荣	角法	角法
.XXX	±0.10	.XXX	±0.5°	DATE		APPD		版本	AO