

LOW VOLTAGE MOSFET (N-CHANNEL)
FEATURES

- $V_{DS}=30V, R_{DS(ON)} \leq 8.5m\Omega @ V_{GS}=10V, I_D=20A$
- Ultra Low on-resistance
- For Low power DC to DC converter application
- For Load switch application
- Surface Mount device

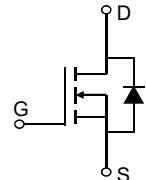
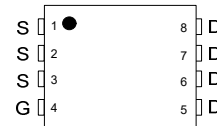
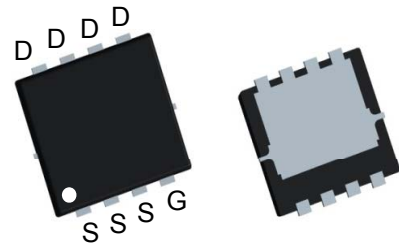

PDFN3333

MECHANICAL DATA

- Case: PDFN3333
- Case Material: Molded Plastic. UL flammability
- Classification Rating: 94V-0
- Weight: 0.012 grams (approximate)
- Marking: Q50N03

MAXIMUM RATINGS ($T_A = 25^\circ\text{C}$ unless otherwise noted)

Symbol	Parameter	Rating	Units
V_{DS}	Drain-Source Voltage	30	V
V_{GS}	Gate-Source Voltage	± 20	V
$I_D @ T_C=25^\circ\text{C}$	Continuous Drain Current ¹	50	A
$I_D @ T_C=100^\circ\text{C}$	Continuous Drain Current ¹	30	A
I_{DM}	Pulsed Drain Current ²	112	A
EAS	Single Pulse Avalanche Energy ³	24	mJ
I_{AS}	Avalanche Current	22	A
$P_D @ T_C=25^\circ\text{C}$	Total Power Dissipation ⁴	37	W
T_{STG}	Storage Temperature Range	-55 to 150	$^\circ\text{C}$
T_J	Operating Junction Temperature Range	-55 to 150	$^\circ\text{C}$

ELECTRICAL CHARACTERISTICS ($T_A = 25^\circ\text{C}$ unless otherwise specified)

Symbol	Parameter	Conditions	Min.	Typ.	Max.	Unit
BV_{DSS}	Drain-Source Breakdown Voltage	$V_{GS}=0V, I_D=250\mu A$	30	---	---	V
$R_{DS(ON)}$	Static Drain-Source On-Resistance ²	$V_{GS}=10V, I_D=20A$		6.8	8.5	m Ω
		$V_{GS}=4.5V, I_D=20A$		9.3	14	m Ω
$V_{GS(th)}$	Gate Threshold Voltage	$V_{GS}=V_{DS}, I_D=250\mu A$	1.0	1.5	3.0	V
I_{DSS}	Drain-Source Leakage Current	$V_{DS}=30V, V_{GS}=0V, T_J=25^\circ\text{C}$	---	---	1	μA
		$V_{DS}=24V, V_{GS}=0V, T_J=125^\circ\text{C}$	---	---	10	
I_{GSS}	Gate-Source Leakage Current	$V_{GS}=\pm 20V, V_{DS}=0V$	---	---	± 100	nA
R_g	Gate Resistance	$V_{DS}=0V, V_{GS}=0V, f=1\text{MHz}$	---	1.8	---	Ω
Q_g	Total Gate Charge (10V)	$V_{DS}=15V, V_{GS}=10V, I_D=20A$	---	9.8	---	nC
Q_{gs}	Gate-Source Charge		---	4.2	---	
Q_{gd}	Gate-Drain Charge		---	3.6	---	
$T_{d(on)}$	Turn-On Delay Time	$V_{DD}=15V, V_{GS}=10V, R_G=3\Omega, I_D=15A$	---	4	---	ns
T_r	Rise Time		---	8	---	
$T_{d(off)}$	Turn-Off Delay Time		---	30	---	
T_f	Fall Time		---	4	---	
C_{iss}	Input Capacitance	$V_{DS}=15V, V_{GS}=0V, f=1\text{MHz}$	---	940	---	pF
C_{oss}	Output Capacitance		---	130	---	
C_{riss}	Reverse Transfer Capacitance		---	110	---	

LOW VOLTAGE MOSFET (N-CHANNEL)

Typical Characteristics

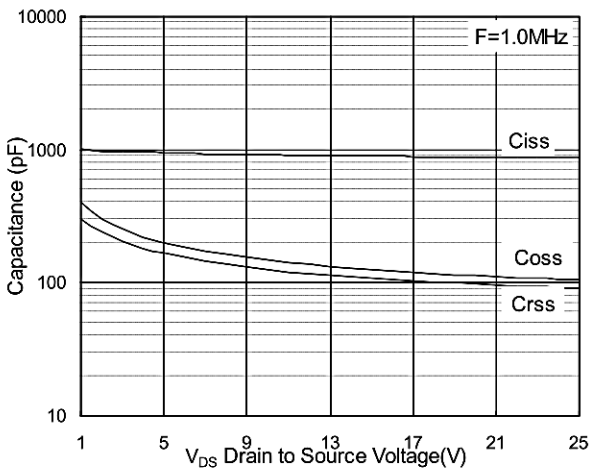

Fig.7 Capacitance

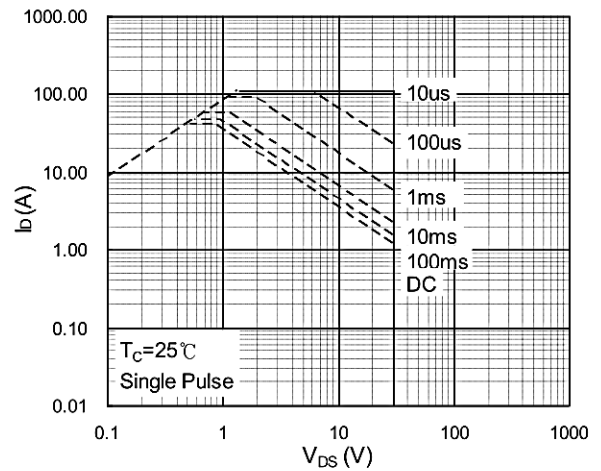

Fig.8 Safe Operating Area

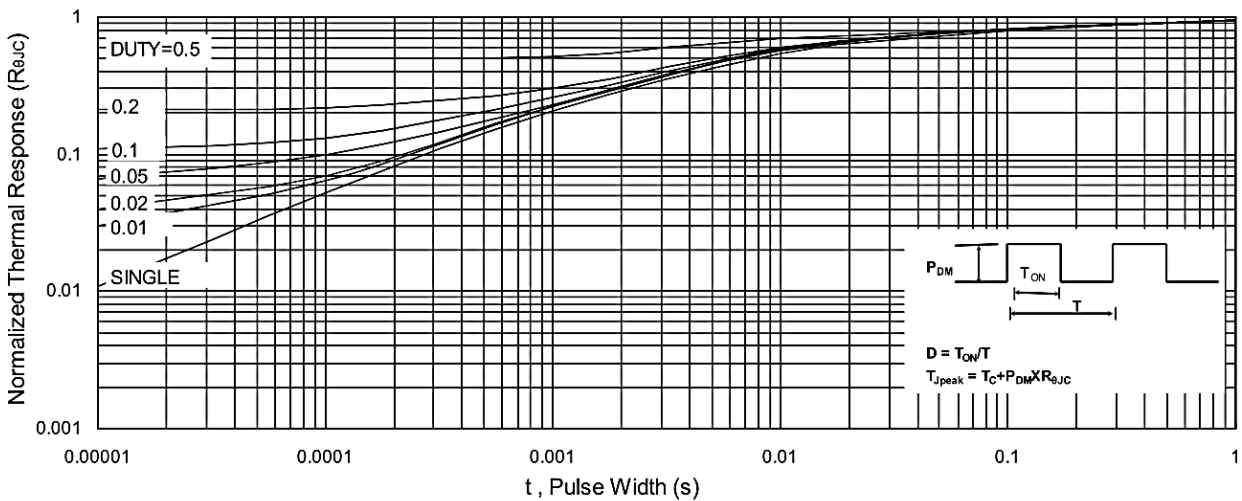

Fig.9 Normalized Maximum Transient Thermal Impedance

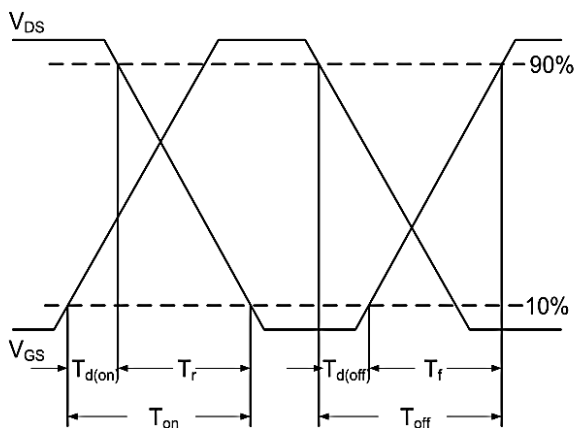

Fig.10 Switching Time Waveform

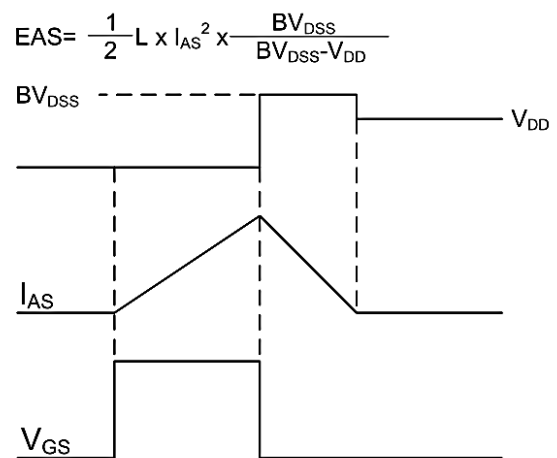
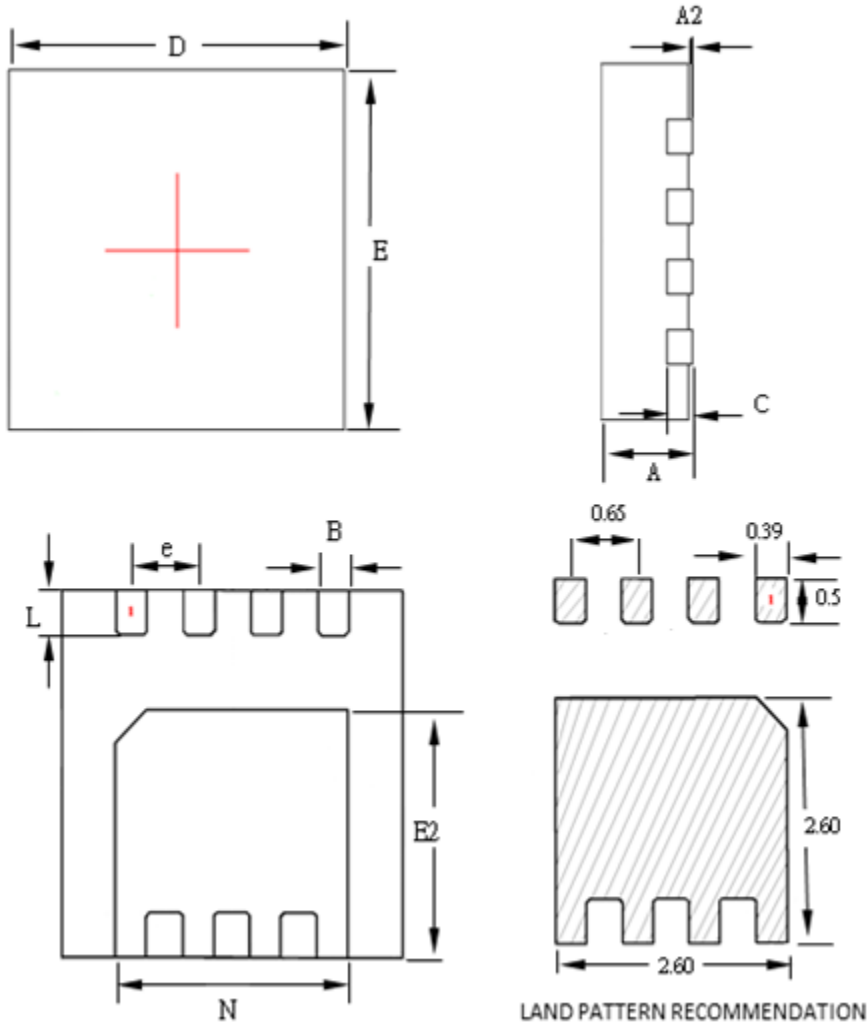

Fig.11 Unclamped Inductive Switching Waveform

LOW VOLTAGE MOSFET (N-CHANNEL)

PDFN3333



SYMBOLS	MILLIMETERS			INCHES		
	MIN	NOM	MAX	MIN	NOM	MAX
A	0.70	0.75	0.80	0.028	0.030	0.031
A2	0.00	--	0.05	0.000	--	0.002
B	0.24	0.30	0.35	0.009	0.012	0.014
C	0.10	0.15	0.25	0.004	0.006	0.010
D	3.15	3.30	3.40	0.124	0.130	0.134
E	3.15	3.30	3.40	0.124	0.130	0.134
E2	2.15	2.25	2.35	0.085	0.089	0.093
L	0.35	0.40	0.45	0.014	0.016	0.018
N	2.10	2.25	2.35	0.083	0.089	0.093
e	--	0.65	--	--	0.026	--