

APPROVAL SHEET

承 认 书

APPROVED BY

承认客户

DESCRIPTION

型名

ACR Thick Film Chip Resistors

ACR 车规厚膜芯片电阻

DATASHEET NO

规格书号码

IE-VO-010

APPROVAL DATE

承认日期



Provider Approval

批准 Approved by	审核 Checked by	承认 Signature

Customer Approval

批准 Approved by	审核 Checked by	承认 Signature

安徽翔胜科技有限公司

地址：安徽省颍上县经济开发区高速连接线综合产业园

电话：0558-2813568/2813578

传真：0558-2813398

1.Scope:

- 1.1 .This specification is applicable to lead free and halogen free of RoHS directive for ACR series thick film chip resistors.
- 1.2.This product is suitable for automotive electronics applications ,Comply with AEC-Q200, Table7 reliability requirements.

2.Explanation Of Part Numbers:

(EX.)

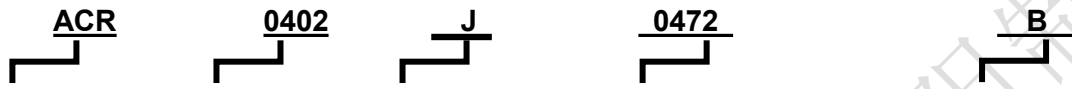

Type	Size	Tolerance	Resistance	Packaging
FCR series Thick Film Chip Resistors	0201 0402 0603 0805 1206 1210 2010 2512	J=± 5%	9R1=09R1 10R=0100 4K7=0472 1M=0105	A: 4 mm Pitch Carrier Tape 5000 pcs B: 2 mm Pitch Carrier Tape 10000 pcs C: 4 mm Pitch Carrier Tape 4000 pcs D: 4 mm Pitch Carrier Tape 20000 pcs E: 2 mm Pitch Carrier Tape 50000 pcs
		F=± 1%	9R1=9R10 10R=10R0 4K7=4701 1M=1004	

3.General Specifications:

3.1resistance range: $\geq 1\Omega$ & 0Ω

Type	Rated Power at 70℃	Max. Working Voltage	Max. Overload Voltage	T.C.R (ppm/℃)	Resistance Range		JUMPER (0Ω)	Operating Temperature Range
					F(±1%) E-24、E-96	J(±5%) E-24		
0201	$\frac{1}{20}$ W	25V	50V	±400	$1\Omega \leq R < 9.1\Omega$	$1\Omega \leq R < 9.1\Omega$	50mΩ MAX.	-55℃ ~ +125℃
				±200	$10\Omega \leq R \leq 10M\Omega$	$10\Omega \leq R \leq 10M\Omega$		
0402	$\frac{1}{16}$ W	50V	100V	±100	$10\Omega \leq R < 1M\Omega$	---	50mΩ MAX.	-55℃ ~ +155℃
				±400	$1\Omega \leq R < 9.1\Omega$	$1\Omega \leq R < 9.1\Omega$		
				±200	$1M\Omega \leq R \leq 10M\Omega$	$10\Omega \leq R \leq 10M\Omega$		
0603	$\frac{1}{10}$ W	75V	150V	±100	$10\Omega \leq R < 1M\Omega$	---	50mΩ MAX.	-55℃ ~ +155℃
				±400	$1\Omega \leq R < 9.1\Omega$	$1\Omega \leq R < 9.1\Omega$		
				±200	$1M\Omega \leq R \leq 10M\Omega$	$10\Omega \leq R \leq 10M\Omega$		
0805	$\frac{1}{8}$ W	150V	300V	±100	$10\Omega \leq R < 1M\Omega$	---	50mΩ MAX.	-55℃ ~ +155℃
				±400	$1\Omega \leq R < 9.1\Omega$	$1\Omega \leq R < 9.1\Omega$		
				±200	$1M\Omega \leq R \leq 10M\Omega$	$10\Omega \leq R \leq 10M\Omega$		
1206	$\frac{1}{4}$ W	200V	400V	±100	$10\Omega \leq R < 1M\Omega$	---	50mΩ MAX.	-55℃ ~ +155℃
				±400	$1\Omega \leq R < 9.1\Omega$	$1\Omega \leq R < 9.1\Omega$		
				±200	$1M\Omega \leq R \leq 10M\Omega$	$10\Omega \leq R \leq 10M\Omega$		

Type	Rated Power at 70°C	Max. Working Voltage	Max. Overload Voltage	T.C.R (ppm/°C)	Resistance Range		JUMPER (0Ω)	Operating Temperature Range
					F(±1%) E-24、E-96	J(±5%) E-24		
1210	1/2 W	200V	400V	±100	10Ω ≤ R < 1MΩ	---	50mΩ MAX.	-55°C ~ +155°C
				±400	1Ω ≤ R < 9.1Ω	1Ω ≤ R < 9.1Ω		
				±200	1MΩ ≤ R ≤ 10MΩ	10Ω ≤ R ≤ 10MΩ		
2010	3/4 W	200V	400V	±100	10Ω ≤ R < 1MΩ	---	50mΩ MAX.	
				±400	1Ω ≤ R < 9.1Ω	1Ω ≤ R < 9.1Ω		
				±200	1MΩ ≤ R ≤ 10MΩ	10Ω ≤ R ≤ 10MΩ		
2512	1 W	200V	400V	±100	10Ω ≤ R < 1MΩ	---	50mΩ MAX.	
				±400	1Ω ≤ R < 9.1Ω	1Ω ≤ R < 9.1Ω		
				±200	1MΩ ≤ R ≤ 10MΩ	10Ω ≤ R ≤ 10MΩ		

3.2. Power Derating Curve:

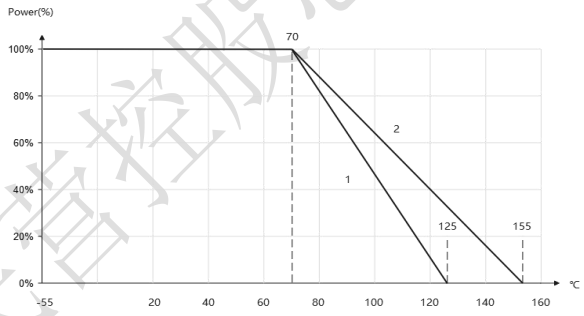
Type	0201/0402/0603/0805/1206/1210/2010/2512
Operating Temperature Range	-55°C ~ +125°C (For 0201) -55°C ~ +155°C
Explain	For resistors operated in ambient temperatures above 70°C, power rating shall be derated in accordance with figure below. (Figure 1: For 0201 Type, Figure 2: For Other's Type)
Figure	

3.3. Voltage Rating :

Rated Voltage: The resistor shall have a DC continuous working voltage or a rms. AC continuous working voltage at commercial-line frequency and wave form corresponding to the power rating, as determined from the following.

$$E = \sqrt{R \times P}$$

E= Rated voltage (V)
P=Power rating (W)
R=Nominal resistance (Ω)

4. Dimensions:

Resistance Range: $\geq 1\Omega$ & 0Ω

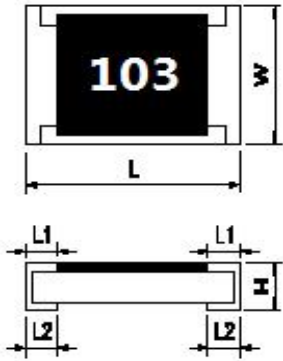

Dimensions Type	L	W	H	L1	L2
0201	0.60±0.03	0.3±0.03	0.23±0.03	0.10±0.05	0.15±0.05
0402	1.00±0.10	0.50±0.05	0.30±0.05	0.20±0.10	0.25±0.10
0603	1.60±0.10	0.80±0.10	0.45±0.10	0.30±0.15	0.25±0.15
0805	2.00±0.10	1.25±0.10	0.50±0.10	0.35±0.20	0.35±0.20
1206	3.05±0.10	1.55±0.10	0.50±0.10	0.45±0.20	0.40±0.20
1210	3.05±0.10	2.60±0.15	0.55±0.10	0.45±0.20	0.50±0.20
2010	5.00±0.10	2.50±0.15	0.55±0.10	0.45±0.20	0.50±0.20
2512	6.35±0.10	3.10±0.15	0.55±0.10	0.60±0.20	0.50±0.20

5. Structure Graph:

Resistance Range: $\geq 1\Omega$ & 0Ω

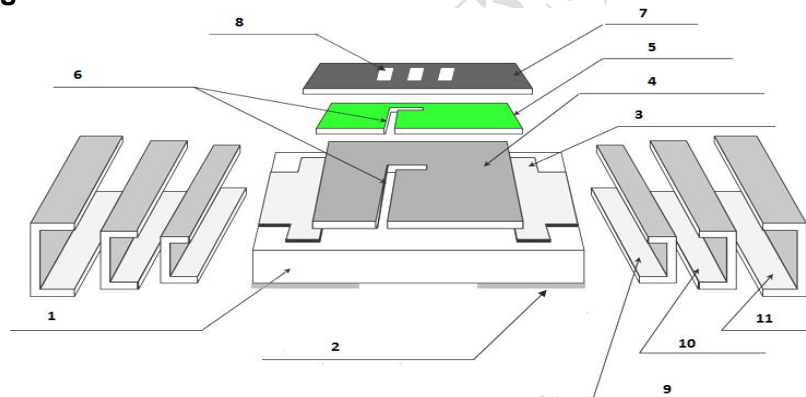

1	陶瓷基板	Ceramic substrate	7	2nd 保护层	2nd Protective coating
2	背面内部电极	Bottom inner electrode	8	字码	Marking
3	正面内部电极	Top inner electrode	9	侧面内部电极	Terminal inner electrode
4	电阻层	Resistive layer	10	Ni 层电镀	Ni plating
5	1st 保护层	1st Protective coating	11	Sn 层电镀	Sn plating
6	镭射修阻	Laser Trimmed	-	-	-

6. Marking Diagrams:

Type	Tolerance(容差)	J	F
0201/0402		No Marking	No Marking
0603		3 字码	参考 6.3 项
0805/1206/1210/2010/2512		3 字码	4 字码

6.1. 0603/0805/1206/1210/2010/2512 ±5% Tolerance:

- Resistance Range $\geq 10\Omega$: 3 digits in E-24 series, first two digits are significant figures, third digit is multiplier (10^x).

<例> Marking → 100

$$100 = 10 * 10^0 = 10\Omega$$



- Resistance Range $< 10\Omega$: 3 digits in E-24 series, first and third digits are significant figures, second digit is multiplier (10^{-1}).

<例> Marking → 4R7

$$4R7 = 47 * 10^{-1} = 4.7\Omega$$



6.2. 0603/0805/1206/1210/2010/2512 ±1% Tolerance:

- Resistance Range $\geq 100\Omega$: 4 digits in E-24 series or E-96 series, first three digits are significant figures, fourth digit is multiplier (10^x).

<例> Marking → 1002

$$1002 = 100 * 10^2 = 10000\Omega$$



- Resistance Range $< 100\Omega$: 4 digits in E-24 series or E-96 series, three digits are significant figures, R digit is multiplier (10^x).

<例> Marking → 10R2

$$10R2 = 102 * 10^{-1} = 10.2\Omega$$



6.3. 0603 ±1% Tolerance:

- For EIAJ-96 Marking If the resistance is not in E-96 series and in E-24 series, the marking is expressed by E-24 series and one short bar under marking letter.

<例> Marking → 47B

$$47B = 301 * 10^1 = 3010\Omega$$



<例> Marking → 471

$$471 = 47 * 10^1 = 470\Omega$$



6.4. 0603/0805/1206/1210/2010/2512 : The marking is expressed by "0".

±1% & ±5% 容差



字碼表

E-12 系列

10	12	15	18	22	27
33	39	47	56	68	82

E-24 系列

10	11	12	13	15	16	18	20	22	24	27	30
33	36	39	43	47	51	56	62	68	75	82	91

E-96 系列

100	102	105	107	110	113	115	118	121	124	127	130
133	137	140	143	147	150	154	158	162	165	169	174
178	182	187	191	196	200	205	210	215	221	226	232
237	243	249	255	261	267	274	280	287	294	301	309
316	324	332	340	348	357	365	374	383	392	402	412
422	432	442	453	464	475	487	499	511	523	536	549
562	576	590	604	619	634	649	665	681	698	715	732
750	768	787	806	825	845	866	887	909	931	953	976

EIAJ 代碼表:

代碼	阻值	代碼	阻值	代碼	阻值	代碼	阻值	代碼	阻值	代碼	阻值	代碼	阻值	代碼	阻值
01	100	13	133	25	178	37	237	49	316	61	422	73	562	85	750
02	102	14	137	26	182	38	243	50	324	62	432	74	576	86	768
03	105	15	140	27	187	39	249	51	332	63	442	75	590	87	787
04	107	16	143	28	191	40	255	52	340	64	453	76	604	88	806
05	110	17	147	29	196	41	261	53	348	65	464	77	619	89	825
06	113	18	150	30	200	42	267	54	357	66	475	78	634	90	845
07	115	19	154	31	205	43	274	55	365	67	487	79	649	91	866
08	118	20	158	32	210	44	280	56	374	68	499	80	665	92	887
09	121	21	162	33	215	45	287	57	383	69	511	81	681	93	909
10	124	22	165	34	221	46	294	58	392	70	523	82	698	94	931
11	127	23	169	35	226	47	301	59	402	71	536	83	715	95	953
12	130	24	174	36	232	48	309	60	412	72	549	84	732	96	976

$Y=10^{-2}$ $X=10^{-1}$ $A=10^0$ $B=10^1$ $C=10^2$ $D=10^3$ $E=10^4$ $F=10^5$

7.1. 电气性能试验(Electrical Performance Test)

Item 项目	Conditions 条件	Specifications 规格	
		Resistors	Jumper
High Temperature Exposure (Storage)	Put the specimens in the chamber with temperature of 155±3°C for 1000 hours. Then take them out to stabilize in room temperature for 24±4hr or more, and measure of its resistance variance rate. Experiment evidence: AEC-Q200	1.阻值范围: ≥1Ω 1%:±1.0% 5%:±2.0%	参考3. 规格表
Temperature Cycling	Put the specimens in the High & low temperature test chamber with temperature varies from -55°C to 125°C for 5 minutes and total 1000 cycles. Then take them out to stabilize in room temperature for 24±4hr or more, and measure of its resistance variance rate. Experiment evidence: AEC-Q200	△R%:±2.0% 外观无损伤, 无短路或烧毁现象。	参考3. 规格表
Short Time Overload	Applied 2.5 times rated voltage for 5 seconds and release the load for about 30 minutes, then measure its resistance variance ate. (Rated voltage refer to item 3. general specifications) 依据 JIS-C5201-1 4.13	1%:±1.0% 5%:±2.0% 外观无损伤, 无短路或烧毁现象。	参考3. 规格表

Item 项目	Conditions 条件	Specifications规格	
		Resistors	Jumper
Electrical Characterization	$TCR \text{ (ppm / } ^\circ\text{C)} = \frac{(R2 - R1)}{R1 (T2 - T1)} \times 10^6$ <p>R1: Resistance at room temperature (Ω) R2: Resistance at -55°C or $+125^\circ\text{C}$ (Ω) T1: Room temperature ($^\circ\text{C}$) T2: Temperature -55°C or $+125^\circ\text{C}$</p> <p>Experiment evidence AEC-Q200</p>	参考3.规格表	
ESD	<p>Put the specimens on the test fixture and two (2) discharges (2KVDC) shall be applied to each PUT, one (1) with a positive polarity and one (1) with a negative polarity. Afterwards, the specimens stabilize for 30min or more and measure of its resistance variance rate. The test is performed with direct contact and regular discharge mode. The resistor and capacitor used on the spearhead is 2000Ω and 150pF respectively.</p> <p>Experiment evidence AEC-Q200</p>	<p>1.阻值范围:$\geq 1\Omega$ $\Delta R\% = \pm 3.0\%$</p>	参考3. 规格表
Solderability	<p>Test method: Test item 1 (solder pot test): Method B Precondition: The specimens are subjected to 155°C dry bake for $4\text{hrs} \pm 15\text{min}$. The specimens are immersed into the flux first, then fully immersed into the solder pot, at a temperature of $235 \pm 5^\circ\text{C}$ for $5+0/-0.5$ sec. Then rinse with water and observe the soldering coverage under the microscope. Test item 2 (Leaching test): Method D The specimens are immersed into the flux first, then fully immersed into the solder pot, at a temperature of $260 \pm 5^\circ\text{C}$ for $30+0/-0.5$ sec. Then rinse with water and observe the soldering coverage under the microscope.</p> <p>Experiment evidence AEC-Q200</p>	导体吃锡面积应大于95%。	
Resistance to Soldering Heat	<p>The specimens are fully immersed into the Pb-free solder pot, then take them out to stabilize for 1 hour or more and measure of its resistance variance rate. Temp of solder pot: $260 \pm 5^\circ\text{C}$ Soldering duration: $10 \pm 1\text{sec}$.</p> <p>Experiment evidence AEC-Q200</p>	<p>(1).阻值变化率 $\Delta R\% = \pm 1.0\%$ (2).电极外观无异常,无侧导脱落。</p>	参考3. 规格表

Item 项目	Conditions 条件	Specifications 规格	
		Resistors	Jumper
Board Flex (Bending Test)	Solder the specimens on the test PCB and put the PCBA onto the Bending Tester. Add force at the central part of PCB, and the duration of the applied forces shall be 60 (+ 5) Sec. Measure of its resistance variance rate in load. Bending depth (D): 02、03、05=5mm 01、06、12=3mm 20、25=2mm Experiment evidence: AEC-Q200	(1).阻值变化率 $\Delta R\% = \pm 1.0\%$ (2).外观无损伤、无侧导脱落及本体断裂发生。	参考3. 规格表
Biased Humidity	Solder the specimens on the test PCB and put them into the constant temperature humidity chamber with $85 \pm 2^\circ\text{C}$ and $85 \pm 5\% \text{RH}$. Then apply the test voltage that calculates based on the 10% of rated power for 1000hrs. Then take them out to stabilize in room temperature for $24 \pm 4 \text{hr}$ or more, and measure of its resistance variance rate. Experiment evidence: AEC-Q200	1%: $\pm 2.0\%$ 5%: $\pm 3.0\%$	参考3. 规格表
Operational Life	Solder the specimens on the test PCB and Put them in the chamber with temperature of $125 \pm 3^\circ\text{C}$ and load the voltage for 1000 hours. Then take them out to stabilize in room temperature for $24 \pm 4 \text{hr}$ or more, and measure of its resistance variance rate. Note: The input voltage shall refer to the power de-rating curve (referring to page 2, No.3.1) Experiment evidence: AEC-Q200	1%: $\pm 2.0\%$ 5%: $\pm 3.0\%$	参考3. 规格表

8. Recommend Soldering Method:

8.1. Lead Free IR Reflow Soldering Profile

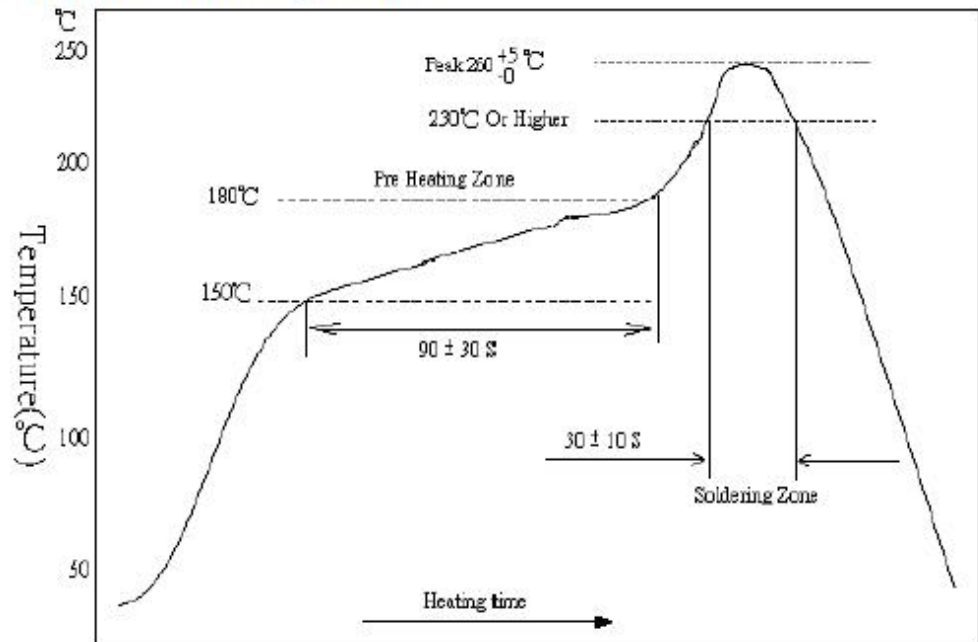

Remark: The peak temperature of soldering heat is $260 \pm 5/0$ °C for 10 seconds.

8.2. Soldering Iron: temperature $350 \text{ °C} \pm 10 \text{ °C}$, dwell time shall be less than 3 sec.

9. Plating Thickness

9.1. Ni : $\cong 2 \mu\text{m}$

9.2. Sn (Tin) : $\cong 3 \mu\text{m}$

9.3. Sn (Tin) : Matte Sn

10. Measurement Point:

Bottom electrode		Unit : mm	
TYPE	DIM	A	B
		0201	0.44±0.05
0402	0.80±0.05	0.24±0.05	
0603	1.35±0.05	0.35±0.05	
0805	1.80±0.05	0.35±0.05	
1206	2.90±0.05	0.35±0.05	
1210	2.90±0.05	0.35±0.05	
2010	4.50±0.05	1.15±0.05	
2512	5.9±0.05	1.60±0.05	

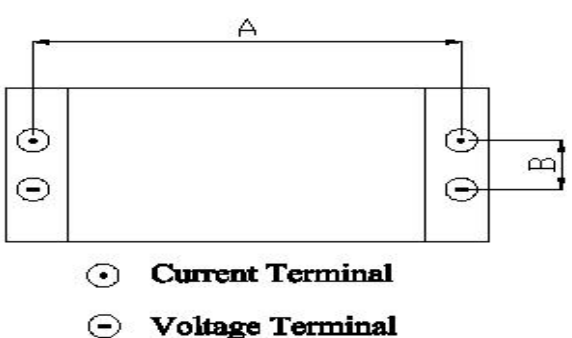

⊙ **Current Terminal**
 ⊖ **Voltage Terminal**

11. Stock period:

The temperature condition must be controlled at -5~40℃, the R.H. must be controlled at 20~75%. The stock can maintain quality level in two years.

12. Product label descrip:

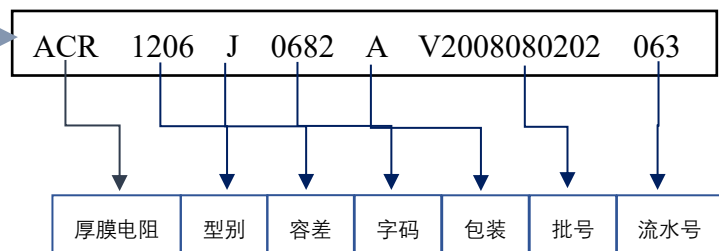

13. Precautions:

Chip resistors are widely used as standard products, so the application of this product may be affected in some specific environments.

1. If you intend to use our products for equipment that requires extremely high reliability (such as medical equipment, aircraft / spacecraft, nuclear power controllers, automotive electronics, etc.), their failure or may cause loss of human life, physical injury or Serious damage to property, please consult with Xiangsheng sales representative in advance. Except with the prior written consent of Xiang Sheng, it shall not be used in any particular application in any way. After use, it will not be liable for any losses and costs caused by you or a third party.

2. Vico designs and manufactures its products according to a strict quality control system. However, electronic products may fail or malfunction in some abnormal applications. Users are required to implement security measures in accordance with their responsibilities, including but not limited to physical injury and damage to any property. The following are examples of security measures:

[A] Install protective circuits or other protective devices to improve system security

[B] Install redundant circuits to reduce the impact of single or multiple circuit failures.

3. Products are not designed to be in special environments or conditions, so performance may be affected when used in the following special environments:

[A] The product is used in any type of liquid, including water, oil, chemicals and organic solvents.

[B] The product is outdoors or in a place where the product is exposed to direct sunlight or dust

[C] The product is exposed to sea wind or corrosive gases, including Cl₂, H₂S, NH₃, SO₂, NO₂

[D] Where the product is exposed to static electricity or electromagnetic waves

[E] The product is near heating parts, plastic ropes, or other flammable items.

[F] Products are sealed or coated with resin or other coating materials

[G] Use unclean flux after product welding, or clean the product with water or water-soluble cleaning agent.

[H] The product is used where dew is condensed.

4. Our products are not designed for radiation protection.
5. Avoid using more than the normal power rating of the product, especially transient loads (applying a large amount of load in a short time, such as pulse applications). May have a negative impact on product performance.
6. Be careful when using hard objects to contact the product, as the product may be damaged due to external forces

国内首家民营控股芯片电阻制造商

安徽翔胜科技有限公司

文件修订记录表

文件名称	ACR 车规厚膜芯片电阻规格书	编号	IE-VO-010
------	-----------------	----	-----------

版本日期	版次	修订页次	修订内容		修订者	备注
			修订前	修订后		
2021.11.16	A	全		新制订	高一	

安徽翔胜科技有限公司

文件制定/更改评审会签表

评审文件清单			
文件编号	文件名称	初版/ 修订	编制人员
IE-V0-010	ACR 车规厚膜芯片电阻规格书	初版	高一
参加评审部门	评审意见		签名/日期
销售部	/		
品保部（含标准化）	同意		
制造部	/		
技术部（含工艺）	同意		
资材部	/		
行政部	/		
财务部	/		
管理者代表	同意		
总经理	/		