

200 W power supply based on STNRG011 digital combo controller for LED TV

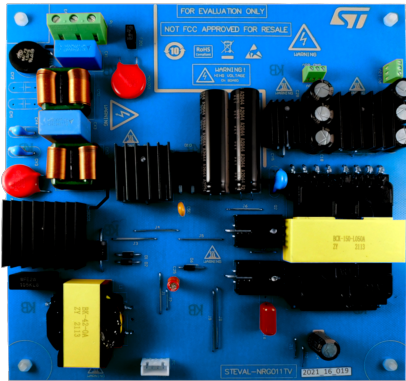

Features

- STNRG011 digital controller:
 - TM PFC with resonant HB-LLC converter
- Input voltage range: 90 – 264 V_{AC}
- 12 V/4 A, 65 V/2.3 A output voltage
- Full load power: 200 W continuous operation
- Full load efficiency greater than 91% at 115 and 230 V_{AC}
- No load mains consumption: less than 120 mW
- Full set of programmable parameters
- High flexibility thanks to the configurable NVM
- Black box functionality with the embedded EEPROM

Description

The STEVAL-NRG011TV is a 200 W LED TV SMPS providing 12 V regulated output voltage (for MCU supply and audio system applications) and 65 V output voltage for LED back lighting.

The design is based on the STNRG011 IC digital combo controller that controls a two-stage AC/DC SMPS.

The front-end is a transition mode PFC pre-regulator and the second stage is an LLC HB resonant converter.

Thanks to the STNRG011 IC, the user can take full advantage of digital implementation without the need of writing code.

A complete set of parameters, stored in the controller non-volatile memory (NVM), allows the configuration and fine tuning of the application.

Product summary	
200 W power supply based on STNRG011 digital combo controller for LED TV	STEVAL-NRG011TV
Digital combo controller multi-mode PFC and time-shift LLC resonant controller	STNRG011
Applications	LED / OLED TV

1 Schematic diagrams

Figure 1. STEVAL-NRG011TV circuit schematic

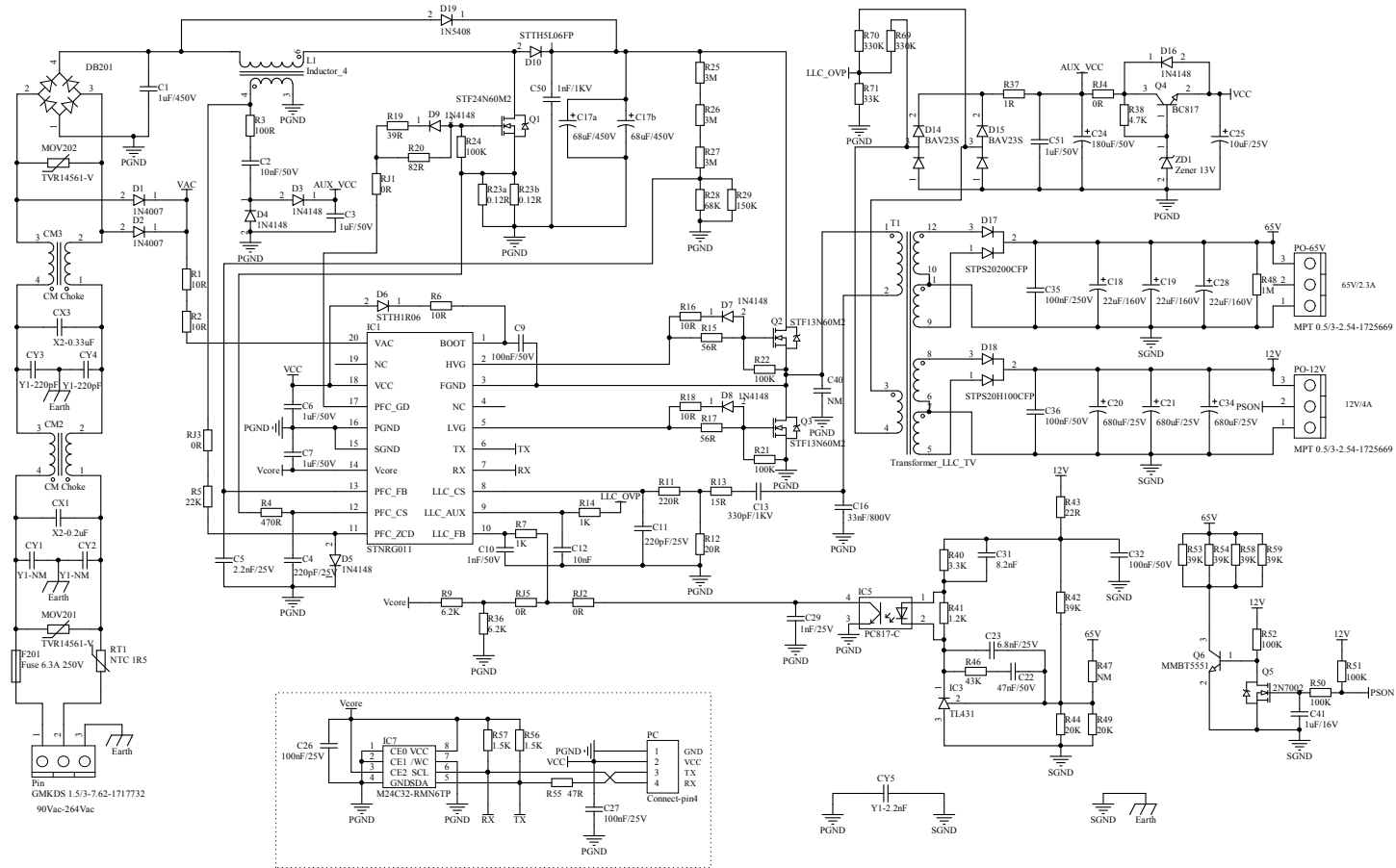

Revision history

Table 1. Document revision history

Date	Version	Changes
14-May-2021	1	Initial release.
16-June-201	2	Updated deescription. Updated product summary

IMPORTANT NOTICE – PLEASE READ CAREFULLY

STMicroelectronics NV and its subsidiaries (“ST”) reserve the right to make changes, corrections, enhancements, modifications, and improvements to ST products and/or to this document at any time without notice. Purchasers should obtain the latest relevant information on ST products before placing orders. ST products are sold pursuant to ST’s terms and conditions of sale in place at the time of order acknowledgement.

Purchasers are solely responsible for the choice, selection, and use of ST products and ST assumes no liability for application assistance or the design of Purchasers’ products.

No license, express or implied, to any intellectual property right is granted by ST herein.

Resale of ST products with provisions different from the information set forth herein shall void any warranty granted by ST for such product.

ST and the ST logo are trademarks of ST. For additional information about ST trademarks, please refer to www.st.com/trademarks. All other product or service names are the property of their respective owners.

Information in this document supersedes and replaces information previously supplied in any prior versions of this document.

© 2021 STMicroelectronics – All rights reserved