

WL2863D

Ultra-Low Noise, High PSRR LDO, 250mA Linear Regulator for RF and Analog Circuits

[Http://www.sh-willsemi.com](http://www.sh-willsemi.com)

Descriptions

The WL2863D is a linear regulator capable of supplying 250-mA output current. Designed to meet the requirements of RF and analog circuits, the WL2863D device provides low noise, high PSRR, low quiescent current and very good load /line transients.

The device is designed to work with a 1 μ F input and 1 μ F output ceramic capacitor (no separate noise Operation bypass capacitor is required).

The WL2863D regulators are available in standard DFN1x1-4L Package. Standard products are Pb-free and Halogen-free.

Features

- Input Voltage Range :2.2V~5.5V
- Output Voltage Range :1.2V~4.3V
- Output current :250mA
- PSRR :Typ.100dB at 10mA , f =1KHz
:Typ. 45dB at 10mA , f =1MHz
- Low Dropout :Typ. 100mV at 250mA
- Quiescent current :Typ. 21 μ A
- Low Output Voltage Noise:Typ. 4.8 μ VRMS
- Output Voltage Tolerance : \pm 1.5%
- Shutdown Current :Typ. 0.01 μ A
- UVLO Threshold(V) :Typ. 1.90V
- Recommend capacitor :1uF
- Stable with 1 μ F Ceramic Input and Output capacitor
- No Noise Bypass Capacitor Required
- Thermal-Overload Protection

Applications

- Cell phones , radiophone, digital cameras
- Bluetooth, wireless handsets
- Hifi products
- Others portable electronics device



DFN1X1-4L

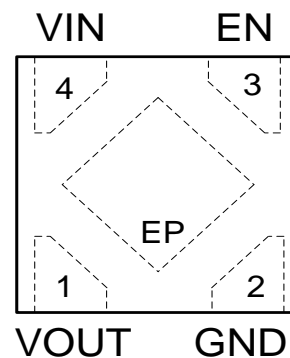

Pin Configuration (Top View)

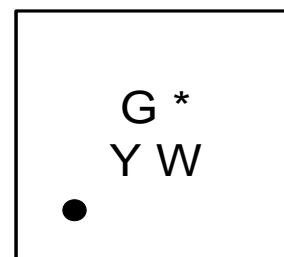

Marking

- G** : Device Code
- *** : Voltage Code
- Y** : Year Code
- W** : Week Codes

Order Information

For detail order information, please see page 8

Typical Application

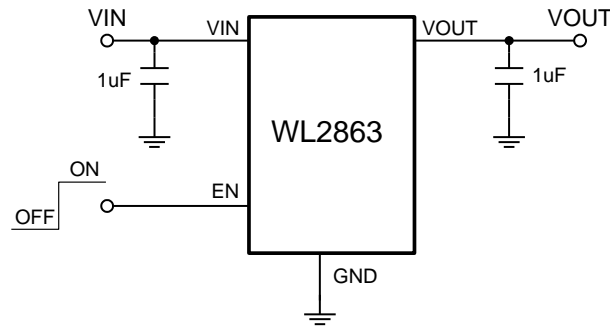

Note : The input and output capacitor must be located a distance of not more than 1 cm

PIN Functions

PIN	Symbol	Description
1	VOUT	Regulated output voltage. 1µF capacitor should be connected at this input
2	GND	Common ground connection
3	EN	Chip enable: Applying $V_{EN} < 0.4\text{ V}$ disables the regulator, Pulling $V_{EN} > 1.2\text{ V}$ enables the LDO.
4	VIN	Input voltage supply pin , 1µF capacitor should be connected at this input
EP		Expose pad can be tied to ground plane for better power dissipation

Block Diagram

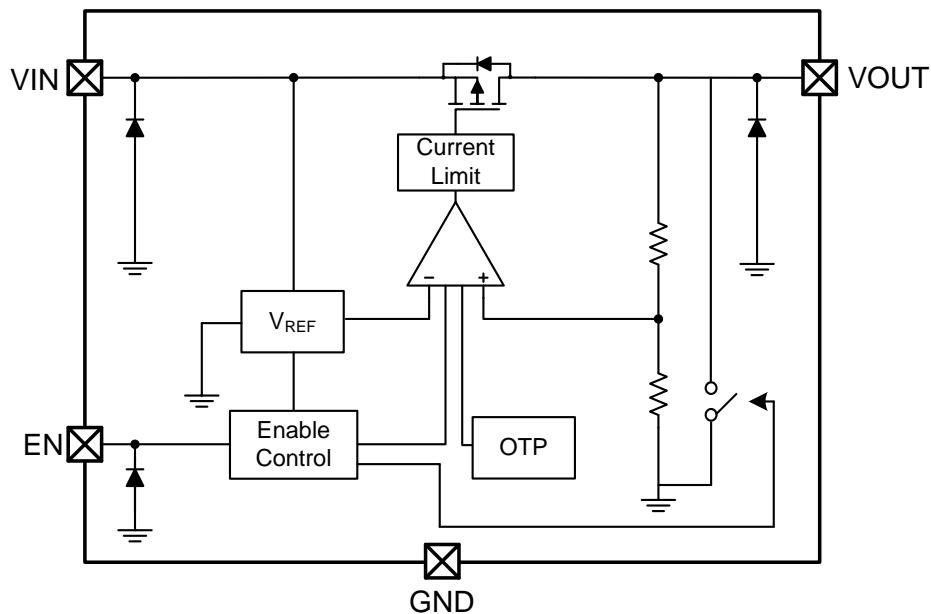

Absolute Maximum Ratings

Parameter	Value	Unit	
Power Dissipation, $P_D @ T_A = 25^\circ\text{C}$	Internally Limited	mW	
V_{IN} Range	-0.3 ~ 6.0	V	
V_{EN} Range	-0.3 to $V_{IN} + 0.3$	V	
V_{OUT} Range	-0.3 to $V_{IN} + 0.3$	V	
I_{OUT}	250	mA	
Lead Temperature Range	260	$^\circ\text{C}$	
Storage Temperature Range	-55 ~ 150	$^\circ\text{C}$	
Operating Junction Temperature Range	150	$^\circ\text{C}$	
ESD Ratings	HBM	2000	V
	MM	200	V

Recommend Operating Ratings

Parameter	Value	Unit
Operating Supply voltage	2.2 ~ 5.5	V
Operating Temperature Range	-40 ~ 85	$^\circ\text{C}$
Thermal Resistance, $R_{\theta JA}$	250	$^\circ\text{C/W}$

Electronics Characteristics ($V_{IN}=V_{OUT(NOM)}+1V$, $C_{IN}=C_{OUT}=1\mu F$, $V_{EN} = 1.2 V$. Typical values are at $T_a = +25^\circ C$, unless otherwise noted)

Parameter	Symbol	Condition	Min.	Typ.	Max.	Unit
Operating Input Voltage	V_{IN}		2.2		5.5	V
Output Voltage Accuracy	V_{OUT}	$V_{IN} = V_{OUT(NOM)} + 1 V$ $I_{OUT}=1mA$	-1.5		+1.5	%
Output Current Limit	I_{LIM}	$V_{OUT} = 90\% V_{OUT(NOM)}$	250			mA
Dropout Voltage		$V_{OUT}=2.8V_{(NOM)}$, $I_{OUT}=250mA$		100	170	mV
		$V_{OUT}=3.0V_{(NOM)}$, $I_{OUT}=250mA$		98	162	
		$V_{OUT}=3.3V_{(NOM)}$, $I_{OUT}=250mA$		92	150	
Line Regulation	ΔV_{LINE}	$V_{IN}=2.2V\sim 5V$, $I_{OUT}=1mA$		0.1		mV
Load Regulation	ΔV_{Load}	$I_{OUT}=1\sim 200mA$		15		mV
Quiescent Current	I_Q	$I_{OUT}=0mA$		21	25	μA
Short Current	I_{SHORT}	$V_{OUT}=0V$		350		mA
Shut-down Current	I_{SHDN}	$V_{EN} < 0.4 V$, $V_{IN} = 4.8 V$		0.01	1.0	μA
Power Supply Rejection Rate	PSRR	$I_{OUT} = 10mA$	$f=100Hz$		90	dB
			$f=1KHz$		100	
			$f=100KHz$		60	
			$f=1MHz$		45	
EN logic high voltage	V_{ENH}	$V_{IN}=5.5V$, $I_{OUT}=1mA$	1.2			V
EN logic low voltage	V_{ENL}	$V_{IN}=5.5V$, $V_{OUT}=0V$			0.4	V
EN Input Current	I_{EN}	$V_{EN} = 0$ to $5.5V$			1	μA
Turn-On Time		$C_{OUT} = 1\mu F$, From assertion of V_{EN} to $V_{OUT} = 95\% V_{OUT(NOM)}$		1.5		mS
Output Voltage Noise	e_{NO}	10Hz to 100KHz,	$I_{OUT} = 1mA$		7	$\mu VRMS$
			$I_{OUT} = 200mA$		4.8	
Thermal shutdown threshold	T_{SDH}	Temperature rising		150		$^\circ C$
	T_{SDL}	Temperature falling		120		$^\circ C$
Under voltage lock out threshold	V_{UVLO}			1.9		V
Active Output Discharge Resistance	R_{LOW}	$V_{EN}<0.4V$		300		Ω
Line Transient	Tran _{LINE}	$V_{IN} = (V_{OUT(NOM)} + 2 V)$ to $(V_{OUT(NOM)} + 1 V)$ in 30 us, $I_{OUT} = 1 mA$	-1			mV
		$V_{IN} = (V_{OUT(NOM)} + 1 V)$ to $(V_{OUT(NOM)} + 2 V)$ in 30 us, $I_{OUT} = 1 mA$			+1	
Load Transient	Tran _{LOAD}	$I_{OUT} = 1 mA$ to $200 mA$ in 10 us	-10			mV
		$I_{OUT} = 200 mA$ to $1 mA$ in 10 us			+10	

Typical characteristics ($T_a=25^\circ\text{C}$, $V_{IN}=3.8\text{V}$, $V_{OUT} = 2.8\text{V}$ $C_{IN}=C_{OUT}=1\mu\text{F}$, unless otherwise noted)

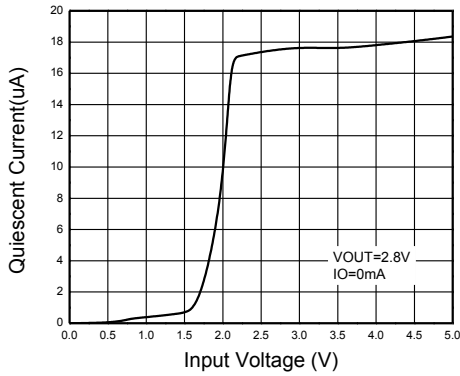

Quiescent current vs. Supply voltage

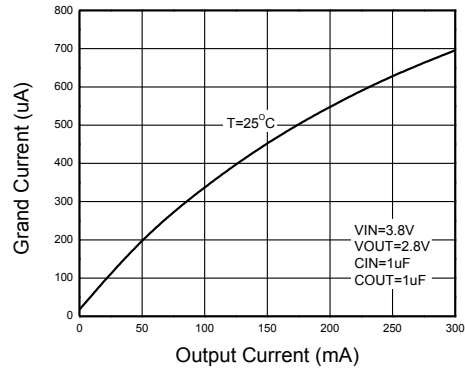

Ground Current vs. Load Current

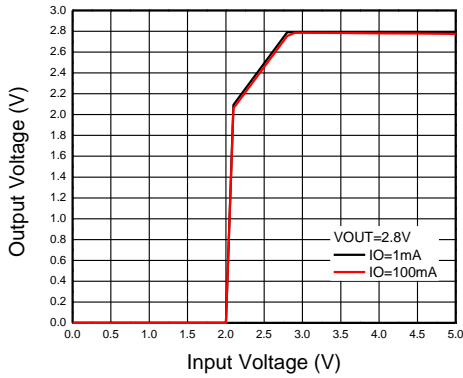

Output voltage vs. Supply voltage

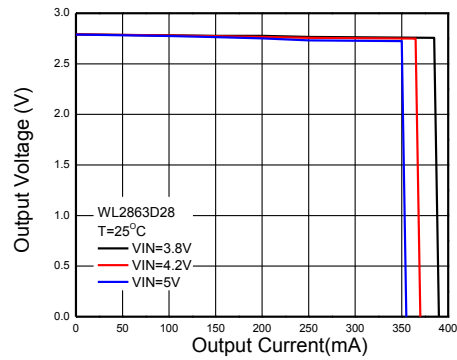

Output voltage vs. Output current

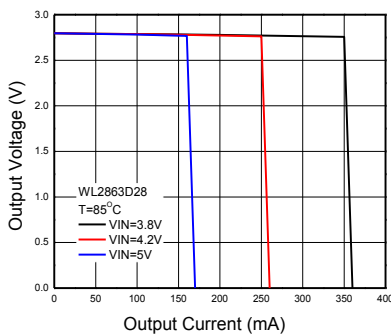

Output voltage vs. Output current

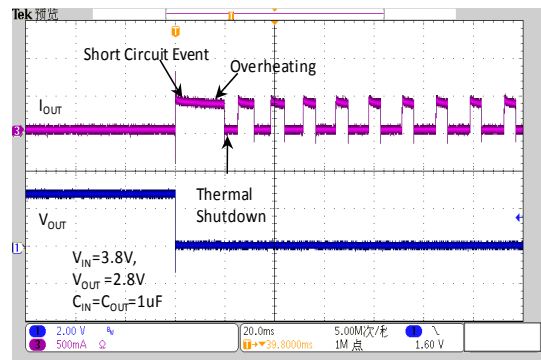

Short Circuit and Thermal Shutdown

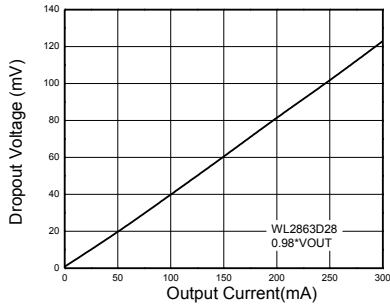
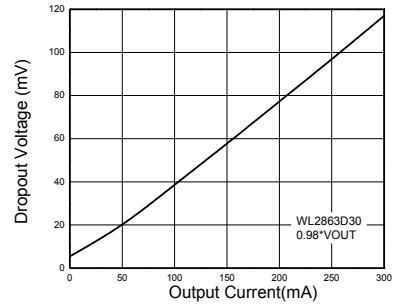
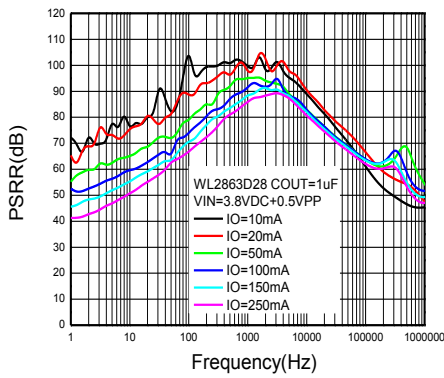
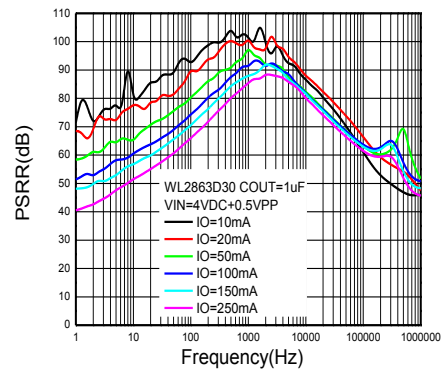
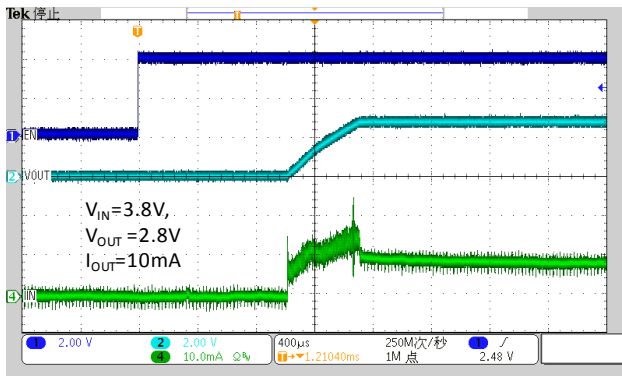
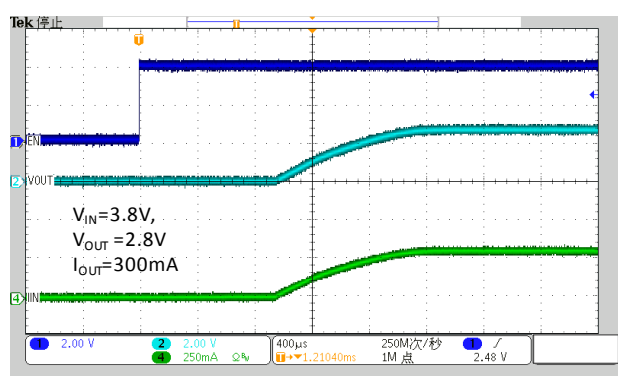
Dropout Voltage vs. Output Current

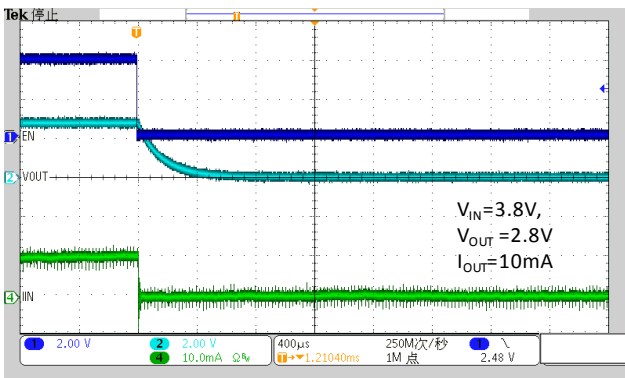
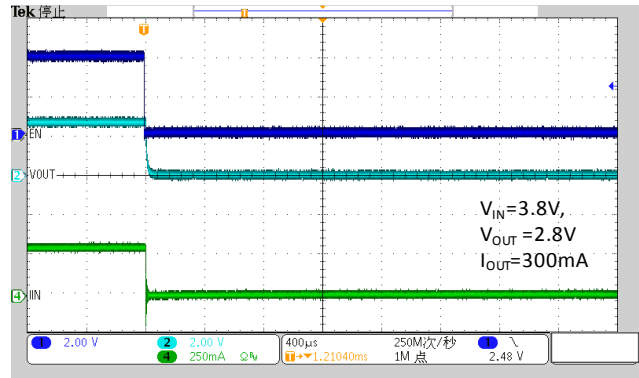
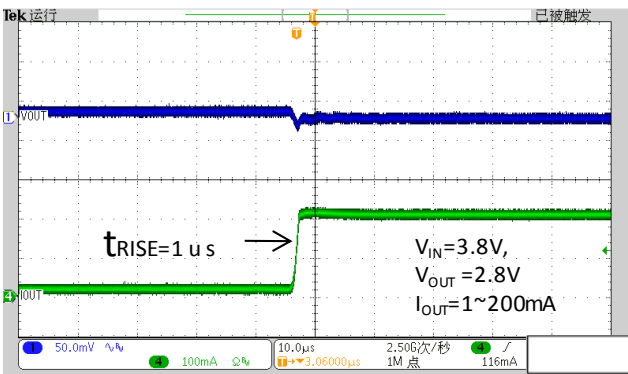
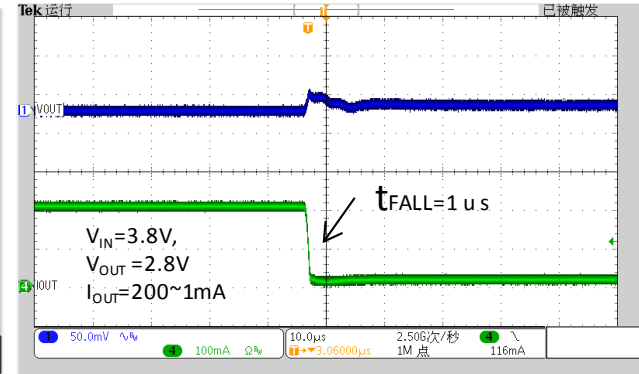
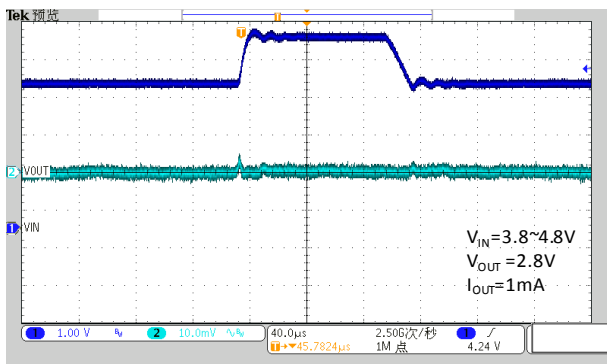
Dropout Voltage vs. Output Current

PSRR

PSRR

Soft-Start From EN

Soft-Start From EN

EN Shutdown

EN Shutdown

Load Transient Response

Load Transient Response

Line Transient Response

ORDER INFORMATION

Ordering No.	Vout (V)	Package	Operating Temperature	Marking	Shipping
WL2863D18-4/TR	1.8	DFN1x1-4L	-40~+85°C	GH YW	Tape and Reel, 10000
WL2863D25-4/TR	2.5	DFN1x1-4L	-40~+85°C	GK YW	Tape and Reel, 10000
WL2863D28-4/TR	2.8	DFN1x1-4L	-40~+85°C	GL YW	Tape and Reel, 10000
WL2863D285-4/TR	2.85	DFN1x1-4L	-40~+85°C	GV YW	Tape and Reel, 10000
WL2863D30-4/TR	3.0	DFN1x1-4L	-40~+85°C	GM YW	Tape and Reel, 10000
WL2863D33-4/TR	3.3	DFN1x1-4L	-40~+85°C	GN YW	Tape and Reel, 10000
WL2863D36-4/TR	3.6	DFN1x1-4L	-40~+85°C	Gf YW	Tape and Reel, 10000

Marking:

G* = Device Code

Y = Year

W = Week

PACKAGE OUTLINE DIMENSIONS

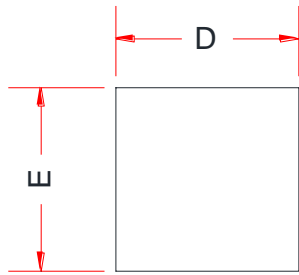
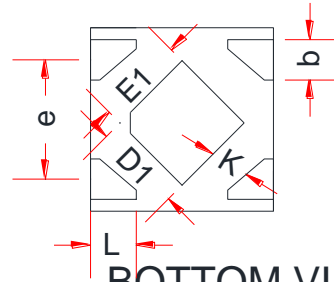
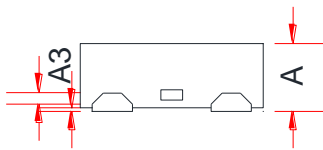
DFN1x1-4L

TOP VIEW

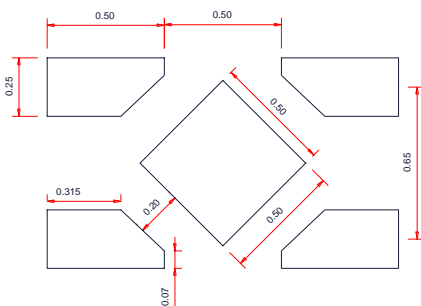
BOTTOM VIEW

SIDE VIEW

Symbol	Dimensions in Millimeters		
	Min.	Typ.	Max.
A	0.34	0.37	0.40
A1	0.00	0.02	0.05
A3	0.10 Ref.		
b	0.17	0.22	0.28
L	0.17	-	0.33
D	0.95	1.00	1.05
E	0.95	1.00	1.05
D1	0.43	0.48	0.53
E1	0.43	0.48	0.53
e	0.65BSC		
K	0.22Ref.		

Recommend PCB Layout (Unit: mm)

Notes:

This recommended land pattern is for reference purposes only. Please consult your manufacturing group to ensure your PCB design guidelines are met.

TAPE AND REEL INFORMATION

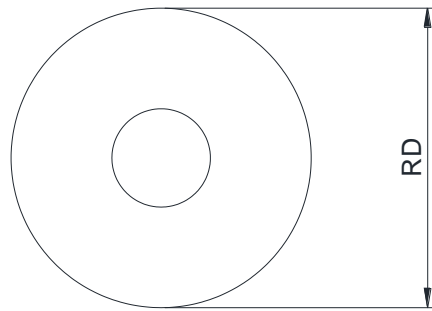
Reel Dimensions



Tape Dimensions

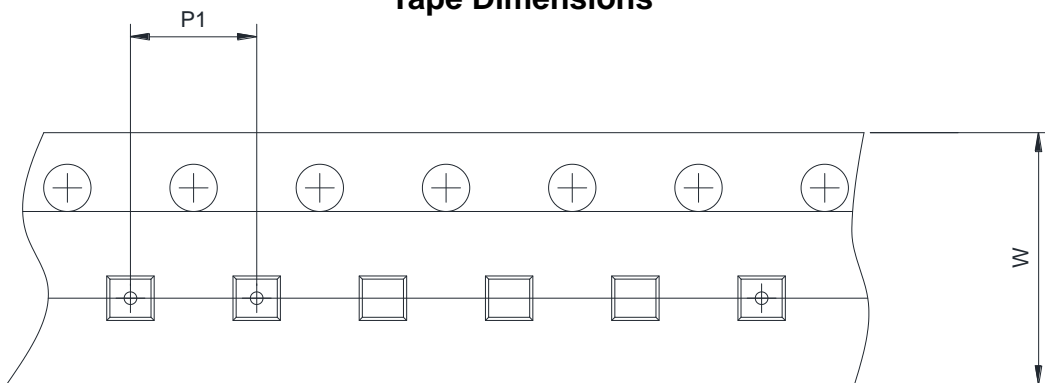

Quadrant Assignments For PIN1 Orientation In Tape

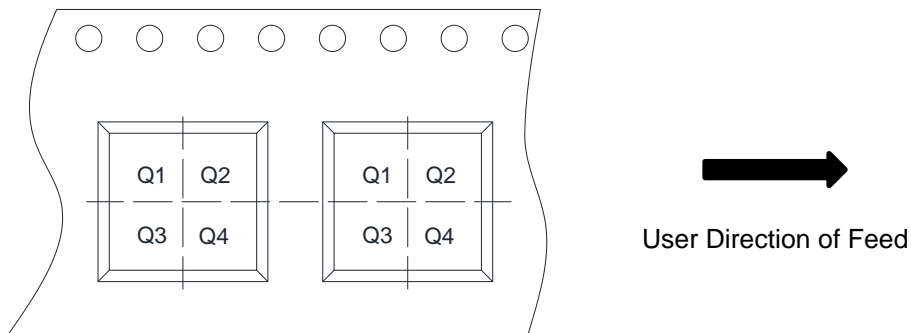

RD	Reel Dimension	<input checked="" type="checkbox"/> 7inch	<input type="checkbox"/> 13inch
W	Overall width of the carrier tape	<input checked="" type="checkbox"/> 8mm	<input type="checkbox"/> 12mm <input type="checkbox"/> 16mm
P1	Pitch between successive cavity centers	<input checked="" type="checkbox"/> 2mm	<input type="checkbox"/> 4mm <input type="checkbox"/> 8mm
Pin1	Pin1 Quadrant	<input checked="" type="checkbox"/> Q1	<input type="checkbox"/> Q2 <input type="checkbox"/> Q3 <input type="checkbox"/> Q4