

PTC Thermistors, Time Delay for Lighting



QUICK REFERENCE DATA		
PARAMETER	VALUE	UNIT
Rated voltage (RMS)	80 to 200	V _{RMS}
Nominal switching current	150 to 500	mA
Resistance at 25 °C (R ₂₅)	100 to 625	Ω
Tolerance on R ₂₅ value	20 to 30	%
Maximum overload current I _{ol}	0.5 to 1.0	A
Tripping time	0.3 to 1	s
Operating temperature range at rated voltage	-20 to 105	°C

DESCRIPTION

Positive temperature coefficient (PTC) thermistors for overload protection have proved to be the ideal electronic ballast component for increased lamp life-time.

When the rectified mains is first applied, the PTC thermistor is cold, so its resistance is low. The lamp voltage will be below the necessary ignition value, so the current will flow through the cathodes, heating them to their emission temperature. At the same time, the PTC thermistor will heat up to its switch temperature, whereupon its resistance will rise rapidly, allowing the lamp voltage to reach its ignition value and light the lamp.

Once the lamp is lit, the cathodes are fed by a high-frequency lamp supply, to avoid flicker and improve efficiency. The PTC thermistor plays no further part until the lamp is switched off, whereupon it is ready to resume its smooth-starting function.

We supply a range of lighting PTC thermistors for this application offering a wide choice of voltage and switch times.

ELECTRICAL DATA AND ORDERING INFORMATION						
R ₂₅ (Ω)		SWITCH TEMPERATURE (°C)	MAXIMUM PEAK VOLTAGE (4) (V _{peak})	TYPICAL (1) TRIP TIME at 25 °C		CATALOG NUMBER
MIN.	MAX.			t _{trip} (s)	at I _t (mA)	
500	750	≈ 110	700	0.4	200	PTCLL05P131TBE (2)
185	300	≈ 120	700	0.5	300	PTCLL05P211TTE (2)
75	125	≈ 80	700	0.7	300	PTCLL05P251TTE (2)
225	375	≈ 105	900	0.75	300	PTCLL07P261VTE (3)
75	125	≈ 105	1 000	0.85	500	PTCLL07P421WTE (3)

Notes

- (1) Ignition time of the lamp approximately equals the tripping time.
- (2) Specific for CFL lamp electronic starter.
- (3) Specific for HF-TL ballast.
- (4) Highest lamp ignition voltage should be smaller than the maximum allowable peak voltage.

FEATURES

- Reliable lamp starting, due to well defined inrush-current generated time delay
- Accurate resistance for ease of circuit design
- Small size and durable
- Available bulk-packed or taped-on-reel
- Long life: More than 20 000 starts for a 20 W CFL lamp
- Material categorization: for definitions of compliance please see www.vishay.com/doc?99912

RoHS
COMPLIANT

APPLICATIONS

Fluorescent lighting and lighting ballasts for:

- CFL 5 to 25 W range
- TL HF-ballasts

MOUNTING

The leads are suitable for soldering in any position. The lacquer may cover the leads up to 1.0 mm from the seating plane.

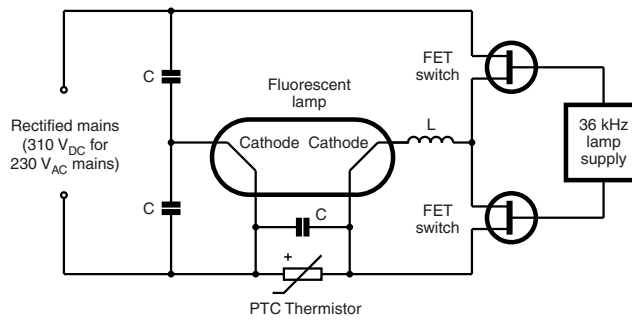
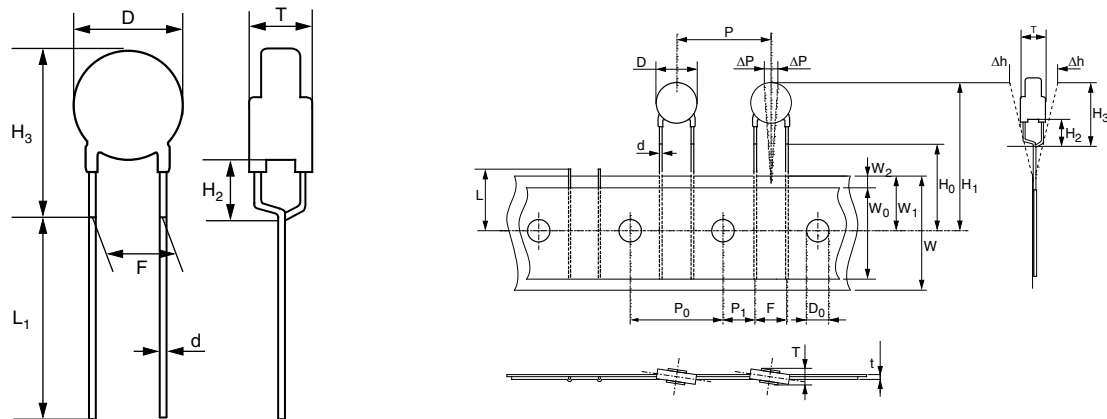
TYPICAL ELECTRONIC BALLAST CIRCUIT

DIMENSIONS in millimeters

D _{max.}	T _{max.}	H ₃	L ₁	WEIGHT (g)	FIGURES	PACKAGING	SPQ	MATERIAL ORDERING NUMBER
5.4	4.5	10	3.5 ± 0.5	≈ 0.33	Fig. 1	Bulk	500	PTCLL05P131TBE
5.4	4.5	9	-	≈ 0.45	Fig. 2	On tape	1500	PTCLL05P211TTE
5.4	4.5	10	-	≈ 0.45	Fig. 2	On tape	1500	PTCLL05P251TTE
7.0	5.0	12	-	≈ 0.66	Fig. 2	On tape	1500	PTCLL07P261VTE
7.0	5.0	12	-	≈ 0.66	Fig. 2	On tape	1500	PTCLL07P421WTE

TAPE AND OTHER DEVICE DIMENSIONS in millimeters according IEC 60286 for tape on reel

SYMBOL	PARAMETER	DIMENSIONS	TOLERANCE
d	Lead diameter	0.6	± 0.05
P	Pitch between thermistors	12.7	± 1
F	Lead to lead distance guaranteed between component and tape	5	+0.5 / -0.2
H ₂	Component body to seating plane	4	± 1
H ₀	Lead-wire clinch height	16	± 0.5



Disclaimer

ALL PRODUCT, PRODUCT SPECIFICATIONS AND DATA ARE SUBJECT TO CHANGE WITHOUT NOTICE TO IMPROVE RELIABILITY, FUNCTION OR DESIGN OR OTHERWISE.

Vishay Intertechnology, Inc., its affiliates, agents, and employees, and all persons acting on its or their behalf (collectively, "Vishay"), disclaim any and all liability for any errors, inaccuracies or incompleteness contained in any datasheet or in any other disclosure relating to any product.

Vishay makes no warranty, representation or guarantee regarding the suitability of the products for any particular purpose or the continuing production of any product. To the maximum extent permitted by applicable law, Vishay disclaims (i) any and all liability arising out of the application or use of any product, (ii) any and all liability, including without limitation special, consequential or incidental damages, and (iii) any and all implied warranties, including warranties of fitness for particular purpose, non-infringement and merchantability.

Statements regarding the suitability of products for certain types of applications are based on Vishay's knowledge of typical requirements that are often placed on Vishay products in generic applications. Such statements are not binding statements about the suitability of products for a particular application. It is the customer's responsibility to validate that a particular product with the properties described in the product specification is suitable for use in a particular application. Parameters provided in datasheets and / or specifications may vary in different applications and performance may vary over time. All operating parameters, including typical parameters, must be validated for each customer application by the customer's technical experts. Product specifications do not expand or otherwise modify Vishay's terms and conditions of purchase, including but not limited to the warranty expressed therein.

Except as expressly indicated in writing, Vishay products are not designed for use in medical, life-saving, or life-sustaining applications or for any other application in which the failure of the Vishay product could result in personal injury or death. Customers using or selling Vishay products not expressly indicated for use in such applications do so at their own risk. Please contact authorized Vishay personnel to obtain written terms and conditions regarding products designed for such applications.

No license, express or implied, by estoppel or otherwise, to any intellectual property rights is granted by this document or by any conduct of Vishay. Product names and markings noted herein may be trademarks of their respective owners.