

## Type TCR Series

### Key Features

Suitable for laser fine tune

Small size and light weight

Highly reliable multilayer electrode construction

Compatible with all soldering process



This Ruthenium based trimmable thick film chip resistor, suitable for laser fine tuning is ideal for use in circuits where a variable resistor might otherwise be used.

### Applications

Tuner

Mobile Phone

Camcorder

Portable Audio

Photo Sensor

Portable Measuring Equipment

### Characteristics – Electrical

Size	Power Rating @70°C	Max. Operating Voltage	Max. Overload Voltage	Tolerance	Resistance Range	TCR (ppm/°C)
0402	0.0625W	50V	100V	+0 ~ -10 +0 ~ -20 +0 ~ -30	1Ω ~ 10MΩ	±200
0603	0.1W	50V	100V		1Ω ~ 9.76 10Ω ~ 1MΩ 1M02 ~ 10MΩ	±200
0805	0.125W	150V	300V			±100
1206	0.25W	200V	400V			±200
1210	0.3W	200V	400V			±100
2010	0.75W	200V	400V			±200
2512	1W	250V	500V			

Operating Temperature range -55 ~ +155°C

Operating Voltage= $V(P \cdot R)$  or Max. operating voltage listed above, whichever is lower.

Overload Voltage= $2.5 \cdot V(P \cdot R)$  or Max. overload voltage listed above, whichever is lower.

### Derating

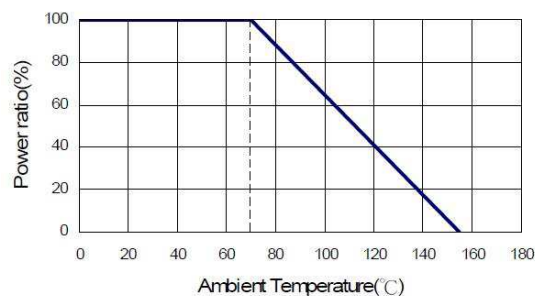

### Environmental Characteristics

Item	Requirement	Test Methods
Temperature Coefficient of Resistance (T.C.R.)	As Spec.	<b>JIS-C-5201-1 4.8</b> <b>IEC-60115-1 4.8</b> -55°C~+125°C, 25°C is the reference temperature
Short Time Overload	±(1.0%+0.05Ω)	<b>JIS-C-5201-1 4.13</b> <b>IEC-60115-1 4.13</b> RCWV*2.5 or Max. Overload Voltage whichever is lower for 5 seconds
Insulation Resistance	≥10G	<b>JIS-C-5201-1 4.6</b> <b>IEC-60115-1 4.6</b> Max. Overload Voltage for 1 minute
Endurance	±(2.0%+0.10Ω)	<b>JIS-C-5201-1 4.25</b> <b>IEC-60115-1 4.25.1</b> 70±2°C, RCWV for 1000 hrs with 1.5 hrs "ON" and 0.5 hr "OFF"
Damp Heat with Load	±(2.0%+0.10Ω)	<b>JIS-C-5201-1 4.24</b> <b>IEC-60115-1 4.24</b> 40±2°C, 90~95% R.H. RCWV for 1000 hrs with 1.5 hrs "ON" and 0.5 hr "OFF"
Dry Heat	±(1.0%+0.05Ω)	<b>JIS-C-5201-1 4.23</b> <b>IEC-60115-1 4.23.2</b> at +125/+155°C for 1000 hrs
Bending Strength	(1.0%+0.05Ω)	<b>JIS-C-5201-1 4.33</b> <b>IEC-60115-1 4.33</b> Bending once for 5 seconds 2010, 2512 sizes: 2mm Other sizes: 3mm
Solderability	95% min. coverage	<b>JIS-C-5201-1 4.17</b> <b>IEC-60115-1 4.17</b> 245±5°C for 3 seconds
Resistance to Soldering Heat	±(0.5%+0.05Ω)	<b>JIS-C-5201-1 4.18</b> <b>IEC-60115-1 4.18</b> 260±5°C for 10 seconds
Voltage Proof	No breakdown or flashover	<b>JIS-C-5201-1 4.7</b> <b>IEC-60115-1 4.7</b> 1.42 times Max. Operating Voltage for 1 minute

### Environmental Characteristics (cont.)

Item	Requirement	Test Methods
Leaching	Individual leaching area $\leq 5\%$ Total leaching area $\leq 10\%$	JIS-C-5201-1 4.18 IEC-60068-2-58 8.2.1 260±5°C for 30 seconds
Rapid Change of Temperature	$\pm(0.5\%+0.05\Omega)$	JIS-C-5201-1 4.19 IEC-60115-1 4.19 -55°C to +125/+155°C, 5 cycles

RCWV(Rated Continuous Working Voltage)= $\sqrt{P \cdot R}$  or Max. Operating Voltage whichever is lower.

Storage Temperature: 15~28°C; Humidity < 80%RH

### Construction and Dimensions

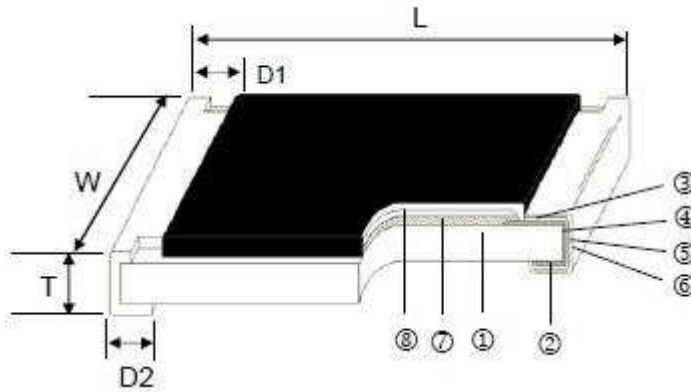

1	Alumina Substrate	5	Barrier Layer
2	Bottom Electrode	6	External Electrode
3	Top Electrode	7	Resistor Layer
4	Edge Electrode	8	Primary Overcoat

Size	L (mm)	W (mm)	T (mm)	D1 (mm)	D2 (mm)	Weight (g) (1000pcs)
0402	1.00±0.05	0.50±0.05	0.35±0.05	0.20±0.10	0.20±0.10	0.620
0603	1.60±0.10	0.80±0.10	0.45±0.10	0.30±0.20	0.30±0.20	2.042
0805	2.00±0.10	1.25±0.10	0.50±0.10	0.35±0.20	0.40±0.20	4.368
1206	3.10±0.10	1.55±0.10	0.55±0.10	0.50±0.25	0.50±0.20	8.947
1210	3.10±0.10	2.60±0.15	0.55±0.10	0.50±0.25	0.50±0.20	15.959
2010	5.00±0.10	2.50±0.15	0.55±0.10	0.60±0.25	0.50±0.20	24.241
2512	6.35±0.10	3.10±0.15	0.55±0.10	0.60±0.25	0.50±0.20	39.448

### Recommended Land Pattern

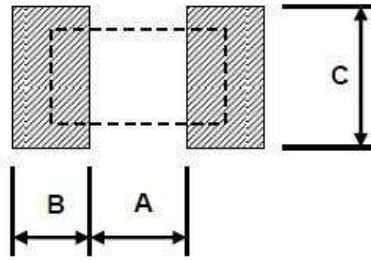

Size	A (mm)	B (mm)	C (mm)
0402	0.50	0.45	0.60
0603	0.90	0.60	0.90
0805	1.20	0.70	1.30
1206	2.00	0.90	1.60
1210	2.00	0.90	2.80
2010	3.80	0.90	2.80
2512	3.80	1.60	3.50

### Soldering Condition

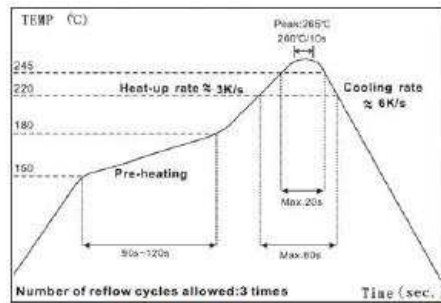

IR Reflow Soldering

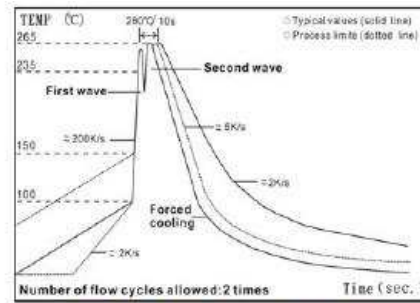

Wave Soldering (Flow Soldering)

- (1) Time of IR reflow soldering at maximum temperature point 260°C : 10s
- (2) Time of wave soldering at maximum temperature point 260°C : 10s
- (3) Time of soldering iron at maximum temperature point 410°C : 5s

## Packaging

### Reel Specification

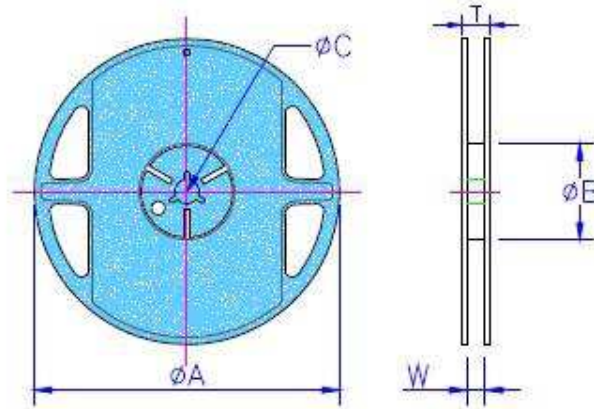

Size	Tape Type	Qty Reel	Tape Width	Reel Nom.	ØA (mm)	ØB (mm)	ØC (mm)	W (mm)	T (mm)
0402	Paper	10K	8mm	7 inch	178.5±1.5	60 <sup>+1</sup> / <sub>-0</sub>	13.0±0.2	9.0±0.5	12.5±0.5
0603	Paper	5K	8mm	7 inch	178.5±1.5	60 <sup>+1</sup> / <sub>-0</sub>	13.0±0.2	9.0±0.5	12.5±0.5
0805	Paper	5K	8mm	7 inch	178.5±1.5	60 <sup>+1</sup> / <sub>-0</sub>	13.0±0.2	9.0±0.5	12.5±0.5
1206	Paper	5K	8mm	7 inch	178.5±1.5	60 <sup>+1</sup> / <sub>-0</sub>	13.0±0.2	9.0±0.5	12.5±0.5
1210	Paper	5K	8mm	7 inch	178.5±1.5	60 <sup>+1</sup> / <sub>-0</sub>	13.0±0.2	9.0±0.5	12.5±0.5
2010	Emboss	4K	12mm	7 inch	178.5±1.5	60 <sup>+1</sup> / <sub>-0</sub>	13.0±0.2	13.0±0.5	15.5±0.5
2512	Plastic	4K	12mm	7 inch	178.5±1.5	60 <sup>+1</sup> / <sub>-0</sub>	13.0±0.2	13.0±0.5	15.5±0.5

### Paper Tape Specification.

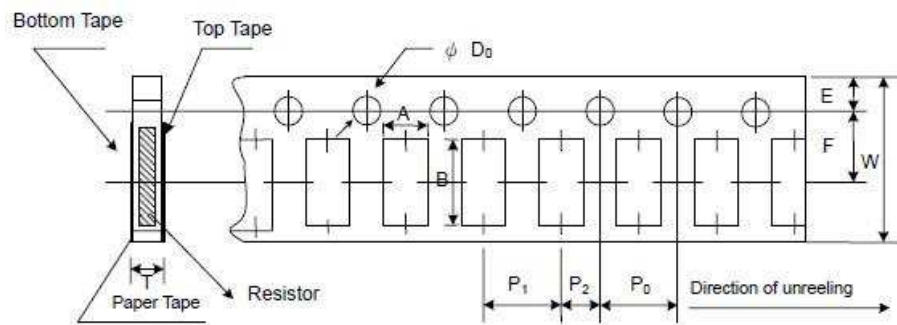

### Dimensions (mm)

Size	A ±0.10	B	W ±0.20	E ±0.10	F ±0.05	P <sub>0</sub> ±0.10	P <sub>1</sub> ±0.05	P <sub>2</sub> ±0.05	ØD <sub>0</sub> +0.1/-0	T ±0.10
0402	0.65	1.15±0.10	8.0	1.75	3.50	4.00	2.00	2.00	1.50	0.45
0603	1.10	1.90±0.10	8.0	1.75	3.50	4.00	4.00	2.00	1.50	0.70
0805	1.60	2.40±0.20	8.0	1.75	3.50	4.00	4.00	2.00	1.50	0.85
1206	1.90	3.50±0.20	8.0	1.75	3.50	4.00	4.00	2.00	1.50	0.85
1210	2.90	3.50±0.20	8.0	1.75	3.50	4.00	4.00	2.00	1.50	0.85

### Embossed Plastic Tape Specification

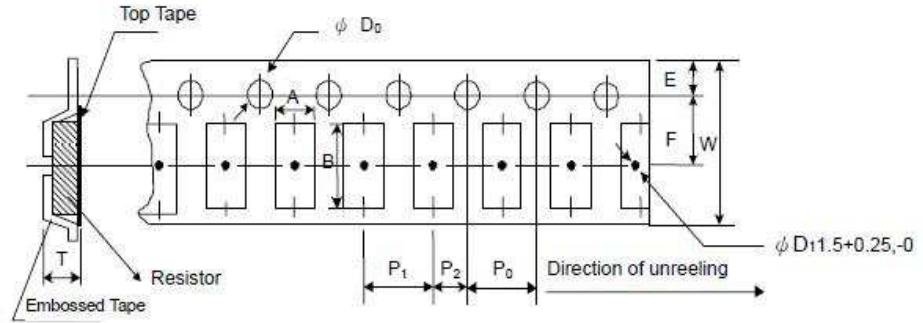

### Dimensions (mm)

Size	A	B	W	E	F	P <sub>0</sub>	P <sub>1</sub>	P <sub>2</sub>	$\phi D_0$	T
2010	±0.10	±0.10	±0.30	±0.10	±0.05	±0.10	±0.10	±0.05	+0.1/-0	±0
2512	3.5	6.7	12.0	1.75	5.5	4.00	4.00	2.00	1.50	1.2

### How To Order

TCR	0805	N	1K5
Common Part	Size	Resistance Tolerance	Resistance
TCR	0402	N: 0 ~ -10% P: 0 ~ -20% Q: 0 ~ -30%	1R2: 1.2 $\Omega$
	0603		100R: 100 $\Omega$
	0805		3K3: 3.3K $\Omega$
	1206		100K: 100K $\Omega$
	1210		1M5: 1.5M $\Omega$
	2010		10M: 10M $\Omega$
	2512		