

Features

- AEC-Q100 Grade 2 temperature range (-40°C to 105°C). Grade 3 and Grade 4 also available
- Any frequency between 220.000001 MHz and 725 MHz, accurate to 6 decimal places. For HCSL output signaling, maximum frequency is 500 MHz – [contact SiTime](#) for higher frequency options. For frequency between 1 and 220 MHz, see [SiT9386](#)
- LVPECL, LVDS and HCSL output signaling
- Frequency stability as low as ±10 ppm – [contact SiTime](#)
- 0.23 ps RMS (typ) phase jitter (random, 12 kHz to 20 MHz)
- Industry-standard packages: 3.2 x 2.5, 7.0 x 5.0 mm. [Contact SiTime](#) for 5.0 x 3.2 mm package

Applications

- 100 Gbps Ethernet, SONET, SATA, SAS, Fibre Channel
- Telecom, networking, instrumentation, storage, servers



Electrical Characteristics

Table 1. Electrical Characteristics – Common to LVPECL, LVDS and HCSL

All Min and Max limits in the Electrical Characteristics tables are specified over temperature and rated operating voltage with standard output termination show in the termination diagrams. Typical values are at 25°C and nominal supply voltage.

Parameter	Symbol	Min.	Typ.	Max.	Unit	Condition
Frequency Range						
Output Frequency Range	f	220.000001	–	725	MHz	Accurate to 6 decimal places
Frequency Stability						
Frequency Stability		-10	–	+10	ppm	Inclusive of initial tolerance, operating temperature, rated power supply voltage and load variations. Contact SiTime for ± 10 ppm
		-20	–	+20	ppm	
		-25	–	+25	ppm	
		-50	–	+50	ppm	
First Year Aging	F_aging1	–	±1	–	ppm	At 25°C
Temperature Range						
Operating Temperature Range	T_use	-20	–	+70	°C	AEC-Q100 Grade 4
		-40	–	+85	°C	AEC-Q100 Grade 3
		-40	–	+105	°C	AEC-Q100 Grade 2
Supply Voltage						
Supply Voltage	Vdd	2.97	3.30	3.63	V	
		2.70	3.00	3.30	V	
		2.52	2.80	3.08	V	
		2.25	2.50	2.75	V	
Input Characteristics						
Input Voltage High	VIH	70%	–	–	Vdd	Pin 1, OE
Input Voltage Low	VIL	–	–	30%	Vdd	Pin 1, OE
Input Pull-up Impedance	Z_in	–	100	–	kΩ	Pin 1, OE logic high or logic low
Output Characteristics						
Duty Cycle	DC	45	–	55	%	
Startup and OE Timing						
Startup Time	T_start	–	–	3.0	ms	Measured from the time Vdd reaches its rated minimum value
OE Enable/Disable Time	T_oe	–	–	3.8	µs	F = 322.265625 MHz. Measured from the time OE pin reaches rated VIH and VIL to the time clock pins reach 90% of swing and high-Z. See Figure 6 and Figure 7

Table 2. Electrical Characteristics – LVPECL Specific

Parameter	Symbol	Min.	Typ.	Max.	Unit	Condition
Current Consumption						
Current Consumption	I _{dd}	–	–	94	mA	Excluding Load Termination Current, V _{dd} = 3.3V or 2.5V
OE Disable Supply Current	I _{OE}	–	–	63	mA	OE = Low
Output Disable Leakage Current	I _{leak}	–	0.15	–	μA	OE = Low
Maximum Output Current	I _{driver}	–	–	33	mA	Maximum average current drawn from OUT+ or OUT-
Output Characteristics						
Output High Voltage	VOH	V _{dd} -1.15	–	V _{dd} -0.7	V	See Figure 2
Output Low Voltage	VOL	V _{dd} -2.0	–	V _{dd} -1.5	V	See Figure 2
Output Differential Voltage Swing	V _{Swing}	1.2	1.6	2.0	V	See Figure 3
Rise/Fall Time	T _r , T _f	–	225	330	ps	20% to 80%, see Figure 3
Jitter – 7.0 x 5.0 mm package						
RMS Period Jitter ^[1]	T _{jitt}	–	1.0	1.6	ps	f = 100, 156.25 or 212.5 MHz, V _{dd} = 3.3V or 2.5V
RMS Phase Jitter (random)	T _{phj}	–	0.220	0.270	ps	f = 322.265625 MHz, Integration bandwidth = 12 kHz to 20 MHz, all V _{dd} levels, includes spurs. Temperature ranges -20 to 70°C and -40 to 85°C
		–	0.220	0.300	ps	f = 322.265625 MHz, Integration bandwidth = 12 kHz to 20 MHz, all V _{dd} levels, includes spurs. Temperature range -40 to 105°C
		–	0.1	–	ps	f = 156.25 or 322.265625 MHz, IEEE802.3-2005 10GbE jitter mask integration bandwidth = 1.875 MHz to 20 MHz, includes spurs, all V _{dd} levels
Jitter – 3.2 x 2.5 mm package						
RMS Period Jitter ^[1]	T _{jitt}	–	1.0	1.6	ps	f = 100, 156.25 or 212.5 MHz, V _{dd} = 3.3V or 2.5V
RMS Phase Jitter (random)	T _{phj}	–	0.225	0.282	ps	f = 322.265625 MHz, Integration bandwidth = 12 kHz to 20 MHz, all V _{dd} levels, includes spurs. Temperature ranges -20 to 70°C and -40 to 85°C
		–	0.225	0.315	ps	f = 322.265625 MHz, Integration bandwidth = 12 kHz to 20 MHz, all V _{dd} levels, includes spurs. Temperature range -40 to 105°C
		–	0.1	–	ps	f = 322.265625 MHz, IEEE802.3-2005 10GbE jitter mask integration bandwidth = 1.875 MHz to 20 MHz, Includes spurs, all V _{dd} levels

Notes:

1. Measured according to JESD65B

Table 3. Electrical Characteristics – LVDS Specific

Parameter	Symbol	Min.	Typ.	Max.	Unit	Condition
Current Consumption						
Current Consumption	I _{dd}	–	–	85	mA	Excluding Load Termination Current, V _{dd} = 3.3V or 2.5V
OE Disable Supply Current	I _{OE}	–	–	63	mA	OE = Low
Output Disable Leakage Current	I _{leak}	–	0.15	–	μA	OE = Low
Output Characteristics						
Differential Output Voltage	V _{OD}	250	–	530	mV	See Figure 4
V _{OD} Magnitude Change	ΔV _{OD}	–	–	50	mV	See Figure 4
Offset Voltage	V _{OS}	1.125	–	1.375	V	See Figure 4
V _{OS} Magnitude Change	ΔV _{OS}	–	–	50	mV	See Figure 4
Rise/Fall Time	T _r , T _f	–	370	505	ps	Measured with 2 pF capacitive loading to GND, 20% to 80%, see Figure 5
Jitter – 7.0 x 5.0 mm package						
RMS Period Jitter ^[2]	T _{jitt}	–	0.92	1.6	ps	f = 100, 156.25 or 212.5 MHz, V _{dd} = 3.3V or 2.5V
RMS Phase Jitter (random)	T _{phj}	–	0.215	0.265	ps	f = 322.265625 MHz, Integration bandwidth = 12 kHz to 20 MHz, all V _{dd} levels, includes spurs. Temperature ranges -20 to 70°C and -40 to 85°C
		–	0.215	0.280	ps	f = 322.265625 MHz, Integration bandwidth = 12 kHz to 20 MHz, all V _{dd} levels, includes spurs. Temperature range -40 to 105°C
		–	0.1	–	ps	f = 322.265625 MHz, IEEE802.3-2005 10GbE jitter mask integration bandwidth = 1.875 MHz to 20 MHz, Includes spurs, all V _{dd} levels
Jitter – 3.2 x 2.5 mm package						
RMS Period Jitter ^[2]	T _{jitt}	–	0.92	1.6	ps	f = 100, 156.25 or 212.5 MHz, V _{dd} = 3.3V or 2.5V
RMS Phase Jitter (random)	T _{phj}	–	0.235	0.282	ps	f = 322.265625 MHz, Integration bandwidth = 12 kHz to 20 MHz, all V _{dd} levels, includes spurs. Temperature ranges -20 to 70°C and -40 to 85°C.
		–	0.235	0.310	ps	f = 322.265625 MHz, Integration bandwidth = 12 kHz to 20 MHz, all V _{dd} levels, includes spurs. Temperature range -40 to 105°C
		–	0.1	–	ps	f = 322.265625 MHz, IEEE802.3-2005 10GbE jitter mask integration bandwidth = 1.875 MHz to 20 MHz, Includes spurs, all V _{dd} levels

Notes:

- Measured according to JESD65B

Table 4. Electrical Characteristics – HCSL Specific

Parameter	Symbol	Min.	Typ.	Max.	Unit	Condition
Current Consumption						
Current Consumption	I _{dd}	–	–	97	mA	Excluding Load Termination Current, V _{dd} = 3.3V or 2.5V
OE Disable Supply Current	I _{OE}	–	–	63	mA	OE = Low
Output Disable Leakage Current	I _{leak}	–	0.15	–	μA	OE = Low
Maximum Output Current	I _{driver}	–	–	35	mA	Maximum average current drawn from OUT+ or OUT-
Output Characteristics						
Output High Voltage	VOH	0.60	–	0.90	V	See Figure 2
Output Low Voltage	VOL	-0.05	–	0.08	V	See Figure 2
Output Differential Voltage Swing	V _{Swing}	1.2	1.4	1.9	V	See Figure 3
Rise/Fall Time	T _r , T _f	–	360	505	ps	Measured with 2 pF capacitive loading to GND, 20% to 80%, see Figure 3
Jitter – 7.0 x 5.0 mm package						
RMS Period Jitter ^[3]	T _{jitt}	–	1.0	1.6	ps	f = 100, 156.25 or 212.5 MHz, V _{dd} = 3.3V or 2.5V
RMS Phase Jitter (random)	T _{phj}	–	0.215	0.265	ps	f = 322.265625 MHz, Integration bandwidth = 12 kHz to 20 MHz, all V _{dd} levels, includes spurs. Temperature ranges -20 to 70°C and -40-85°C
		–	0.215	0.282	ps	f = 322.265625 MHz, Integration bandwidth = 12 kHz to 20 MHz, all V _{dd} levels, includes spurs. Temperature range -40 to 105°C
		–	0.1	–	ps	f = 322.265625 MHz, IEEE802.3-2005 10GbE jitter mask integration bandwidth = 1.875 MHz to 20 MHz, Includes spurs, all V _{dd} levels
Jitter – 3.2 x 2.5 mm package						
RMS Period Jitter ^[3]	T _{jitt}	–	1.0	1.6	ps	f = 100, 156.25 or 212.5 MHz, V _{dd} = 3.3V or 2.5V
RMS Phase Jitter (random)	T _{phj}	–	0.235	0.282	ps	f = 322.265625 MHz, Integration bandwidth = 12 kHz to 20 MHz, all V _{dd} levels, includes spurs. Temperature ranges -20 to 70°C and -40 to 85°C.
		–	0.235	0.305	ps	f = 322.265625 MHz, Integration bandwidth = 12 kHz to 20 MHz, all V _{dd} levels, includes spurs. Temperature range -40 to 105°C
		–	0.1	–	ps	f = 322.265625 MHz, IEEE802.3-2005 10GbE jitter mask integration bandwidth = 1.875 MHz to 20 MHz, Includes spurs, all V _{dd} levels

Notes:

- Measured according to JESD65

Table 5. Pin Description

Pin	Map	Functionality	
1	OE/NC	Output Enable (OE)	H ^[4] : specified frequency output L: output is high impedance
		Non Connect (NC)	H or L or Open: No effect on output frequency or other device functions
2	NC	NA	No Connect; Leave it floating or connect to GND for better heat dissipation
3	GND	Power	Vdd Power Supply Ground
4	OUT+	Output	Oscillator output
5	OUT-	Output	Complementary oscillator output
6	Vdd	Power	Power supply voltage ^[5]

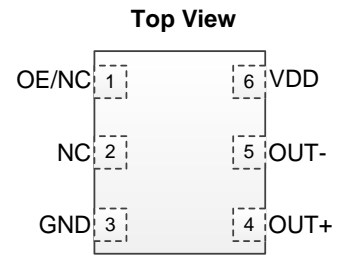

Figure 1. Pin Assignments

Notes:

- 4. In OE mode, a pull-up resistor of 10 kΩ or less is recommended if pin 1 is not externally driven.
- 5. A capacitor of value 0.1 μF or higher between Vdd and GND is required. An additional 10 μF capacitor between Vdd and GND is required for the best phase jitter performance

Table 6. Absolute Maximum Ratings

Attempted operation outside the absolute maximum ratings may cause permanent damage to the part. Actual performance of the IC is only guaranteed within the operational specifications, not at absolute maximum ratings.

Parameter	Min.	Max.	Unit
Vdd	-0.5	4.0	V
V _{IH}		Vdd + 0.3V	V
V _{IL}	-0.3		V
Storage Temperature	-65	150	°C
Maximum Junction Temperature		130	°C
Soldering Temperature (follow standard Pb-free soldering guidelines)		260	°C

Table 7. Thermal Considerations^[6]

Package	θ _{JA} , 4 Layer Board (°C/W)	θ _{JC} , Bottom (°C/W)
3225, 6-pin	80	30
7050, 6-pin	52	19

Notes:

- 6. Refer to JESD51 for θ_{JA} and θ_{JC} definitions, and reference layout used to determine the θ_{JA} and θ_{JC} values in the above table.

Table 8. Maximum Operating Junction Temperature^[7]

Max Operating Temperature (ambient)	Maximum Operating Junction Temperature
70°C	95°C
85°C	110°C
105°C	130°C

Notes:

- 7. Datasheet specifications are not guaranteed if junction temperature exceeds the maximum operating junction temperature.

Table 9. Environmental Compliance

Parameter	Test Conditions	Value	Unit
Mechanical Shock Resistance	MIL-STD-883F, Method 2002	10,000	g
Mechanical Vibration Resistance	MIL-STD-883F, Method 2007	70	g
Soldering Temperature (follow standard Pb free soldering guidelines)	MIL-STD-883F, Method 2003	260	°C
Moisture Sensitivity Level	MSL1 @ 260°C		
Electrostatic Discharge (HBM)	HBM, JESD22-A114	2,000	V
Charge-Device Model ESD Protection	JESD220C101	750	V
Latch-up Tolerance	JESD78 Compliant		

Waveform Diagrams

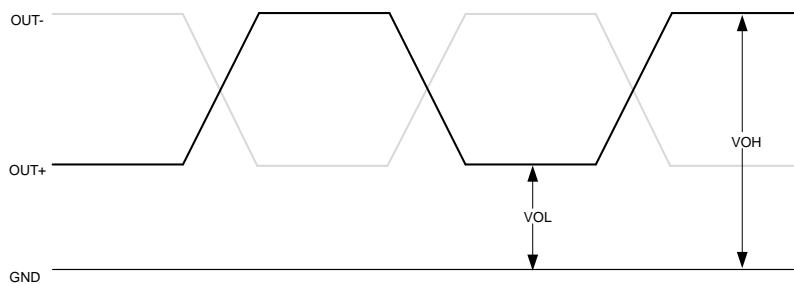

Figure 2. LVPECL/HCSL Voltage Levels per Differential Pin (OUT+/OUT-)

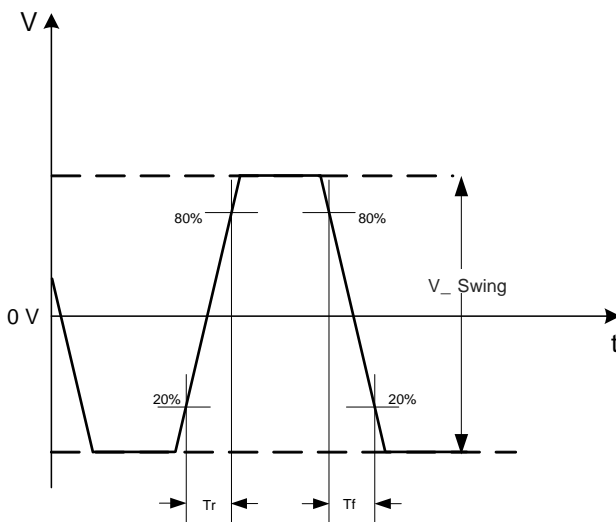

Figure 3. LVPECL/HCSL Voltage Levels across Differential Pair

Waveform Diagrams (continued)

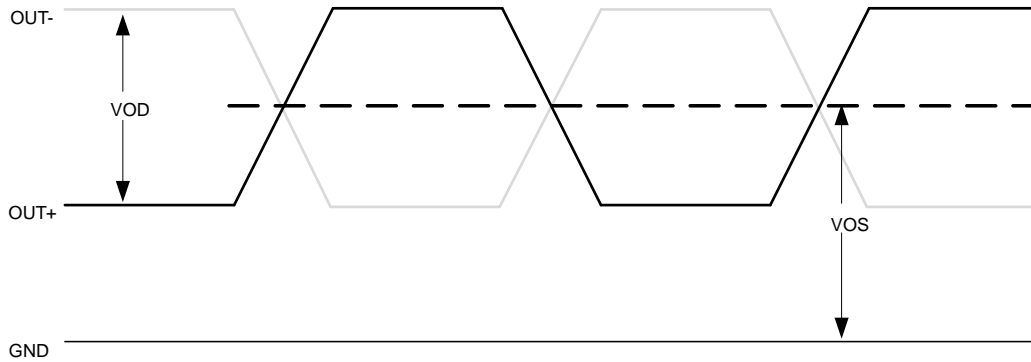

Figure 4. LVDS Voltage Levels per Differential Pin (OUT+/OUT-)

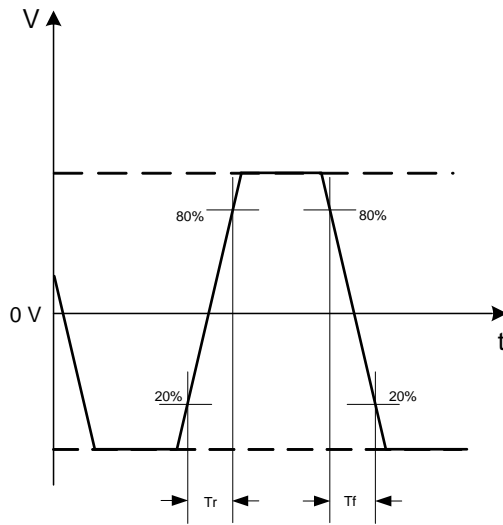

Figure 5. LVDS Differential Waveform

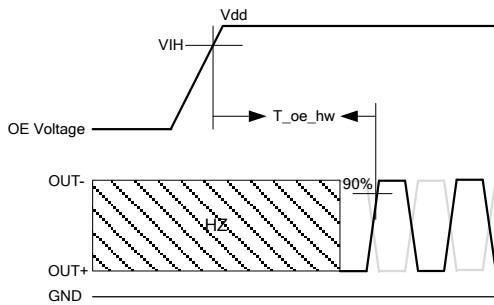

Figure 6. Hardware OE Enable Timing

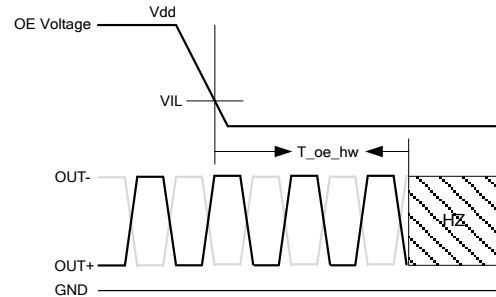

Figure 7. Hardware OE Disable Timing

Termination Diagrams

LVPECL:

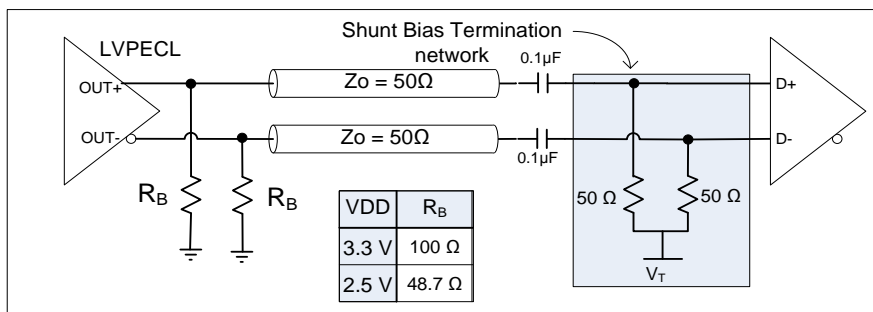

Figure 8. LVPECL with AC-coupled termination

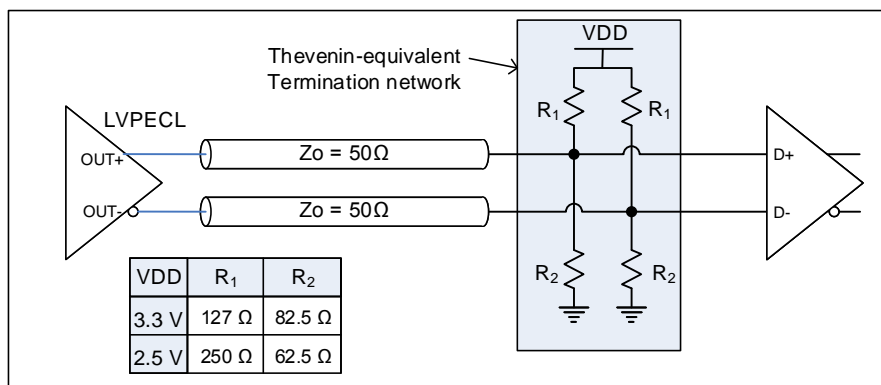

Figure 9. LVPECL DC-coupled load termination with Thevenin equivalent network

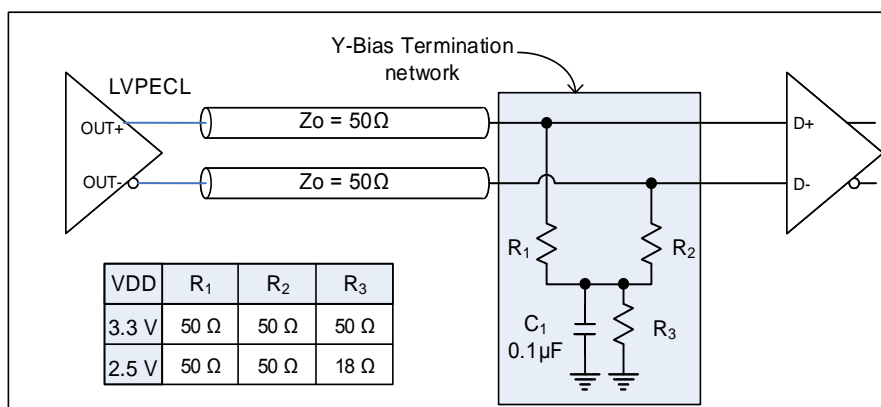

Figure 10. LVPECL with Y-Bias termination

Termination Diagrams (continued)

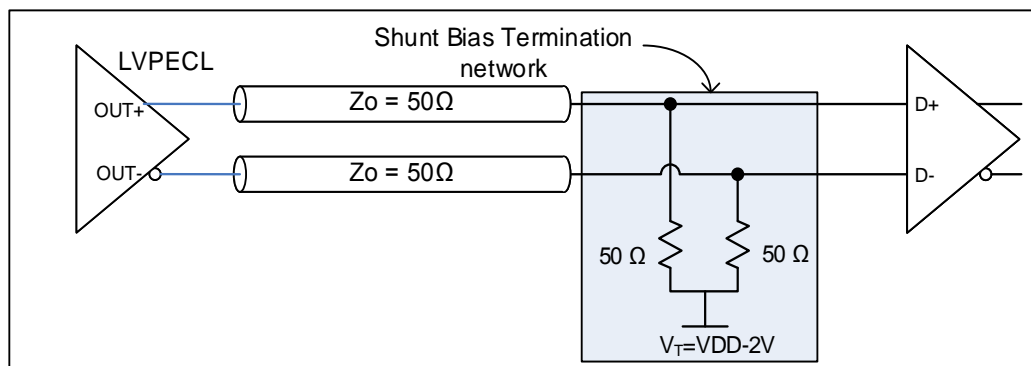

Figure 11. LVPECL with DC-coupled parallel shunt load termination

Termination Diagrams (continued)

LVDS:

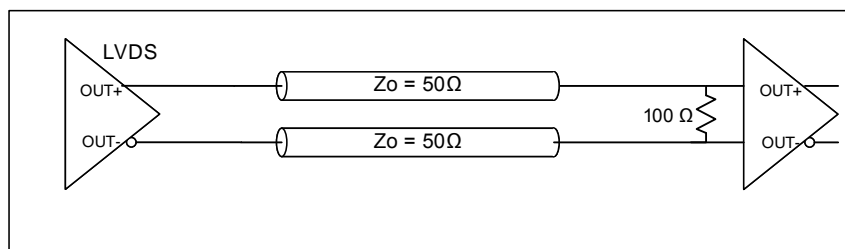

Figure 12. LVDS single DC termination at the load

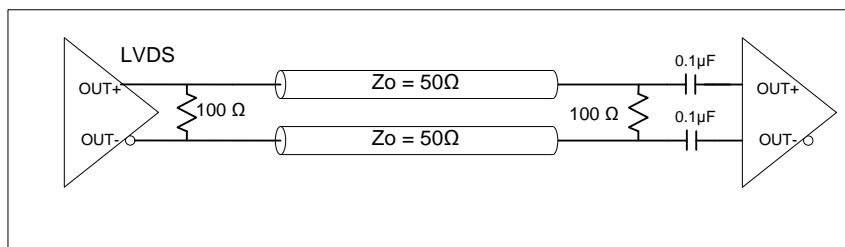

Figure 13. LVDS double AC termination with capacitor close to the load

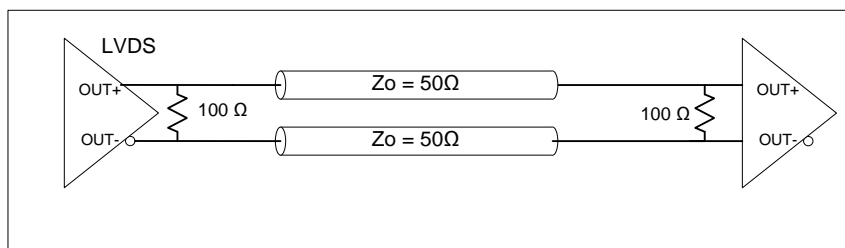

Figure 14. LVDS double DC termination

Termination Diagrams (continued)

HCSL:

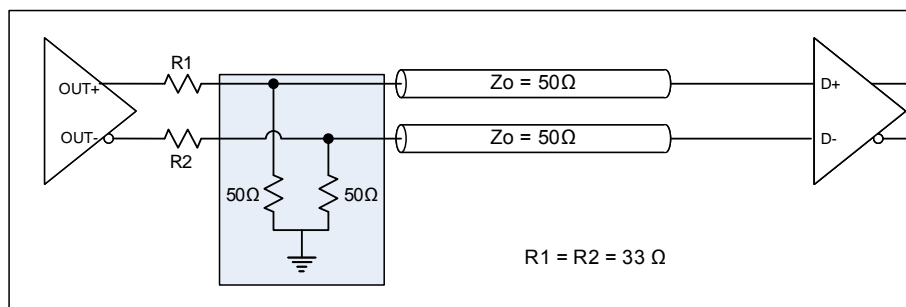

Figure 15. HCSL interface termination

Dimensions and Patterns

Package Size – Dimensions (Unit: mm) ^[8]	Recommended Land Pattern (Unit: mm) ^[9]																																																																																												
<p>3.2 x 2.5 x 0.85 mm</p> <table border="1" style="width:100%; border-collapse: collapse; margin-top: 10px;"> <thead> <tr> <th></th> <th>SYMBOL</th> <th>MIN</th> <th>NOM</th> <th>MAX</th> </tr> </thead> <tbody> <tr> <td>TOTAL THICKNESS</td> <td>A</td> <td>0.800</td> <td>0.850</td> <td>0.900</td> </tr> <tr> <td>STAND OFF</td> <td>A1</td> <td>0.000</td> <td>0.035</td> <td>0.050</td> </tr> <tr> <td rowspan="2">BODY SIZE</td> <td>X</td> <td>D</td> <td>3.200</td> <td>BSC</td> </tr> <tr> <td>Y</td> <td>E</td> <td>2.500</td> <td>BSC</td> </tr> <tr> <td>LEAD WIDTH</td> <td>b</td> <td>0.550</td> <td>0.600</td> <td>0.650</td> </tr> <tr> <td rowspan="2">LEAD LENGTH</td> <td>L</td> <td>0.650</td> <td>0.700</td> <td>0.750</td> </tr> <tr> <td>L1</td> <td></td> <td>1.000</td> <td>REF</td> </tr> <tr> <td>LEAD PITCH</td> <td>e</td> <td></td> <td>1.100</td> <td>BSC</td> </tr> <tr> <td>PACKAGE TOLERANCE</td> <td>aaa</td> <td></td> <td>0.100</td> <td></td> </tr> <tr> <td>MOLD FLATNESS</td> <td>bbb</td> <td></td> <td>0.100</td> <td></td> </tr> <tr> <td>COPLANARITY</td> <td>ccc</td> <td></td> <td>0.080</td> <td></td> </tr> <tr> <td>DIMPLE WIDTH</td> <td>T</td> <td></td> <td>0.300</td> <td>REF</td> </tr> <tr> <td>DIMPLE LENGTH</td> <td>P</td> <td></td> <td>0.150</td> <td>REF</td> </tr> <tr> <td>DIMPLE DEPTH</td> <td>A2</td> <td></td> <td>0.100</td> <td>REF</td> </tr> </tbody> </table> <p>Notes 1. Dimensioning and tolerancing conform to ASME Y14.5-2009 2. All dimensions are in millimeters</p> <table border="1" style="width:100%; border-collapse: collapse; margin-top: 10px;"> <thead> <tr> <th colspan="2" style="text-align: center;">Package Outline</th> </tr> </thead> <tbody> <tr> <td style="text-align: center;">6L PQFD</td> <td style="text-align: center;">PCD-PQFD-006-C03225-038</td> </tr> <tr> <td style="text-align: center;">3.200x2.500x0.850 mm</td> <td style="text-align: center;"></td> </tr> <tr> <td style="text-align: center;">2019/03/13 Rev B00</td> <td></td> </tr> </tbody> </table>		SYMBOL	MIN	NOM	MAX	TOTAL THICKNESS	A	0.800	0.850	0.900	STAND OFF	A1	0.000	0.035	0.050	BODY SIZE	X	D	3.200	BSC	Y	E	2.500	BSC	LEAD WIDTH	b	0.550	0.600	0.650	LEAD LENGTH	L	0.650	0.700	0.750	L1		1.000	REF	LEAD PITCH	e		1.100	BSC	PACKAGE TOLERANCE	aaa		0.100		MOLD FLATNESS	bbb		0.100		COPLANARITY	ccc		0.080		DIMPLE WIDTH	T		0.300	REF	DIMPLE LENGTH	P		0.150	REF	DIMPLE DEPTH	A2		0.100	REF	Package Outline		6L PQFD	PCD-PQFD-006-C03225-038	3.200x2.500x0.850 mm		2019/03/13 Rev B00		<p>3.2 x 2.5 x 0.85 mm</p>											
	SYMBOL	MIN	NOM	MAX																																																																																									
TOTAL THICKNESS	A	0.800	0.850	0.900																																																																																									
STAND OFF	A1	0.000	0.035	0.050																																																																																									
BODY SIZE	X	D	3.200	BSC																																																																																									
	Y	E	2.500	BSC																																																																																									
LEAD WIDTH	b	0.550	0.600	0.650																																																																																									
LEAD LENGTH	L	0.650	0.700	0.750																																																																																									
	L1		1.000	REF																																																																																									
LEAD PITCH	e		1.100	BSC																																																																																									
PACKAGE TOLERANCE	aaa		0.100																																																																																										
MOLD FLATNESS	bbb		0.100																																																																																										
COPLANARITY	ccc		0.080																																																																																										
DIMPLE WIDTH	T		0.300	REF																																																																																									
DIMPLE LENGTH	P		0.150	REF																																																																																									
DIMPLE DEPTH	A2		0.100	REF																																																																																									
Package Outline																																																																																													
6L PQFD	PCD-PQFD-006-C03225-038																																																																																												
3.200x2.500x0.850 mm																																																																																													
2019/03/13 Rev B00																																																																																													
<p>7.0 x 5.0 x 0.85 mm^[10]</p> <table border="1" style="width:100%; border-collapse: collapse; margin-top: 10px;"> <thead> <tr> <th></th> <th>SYMBOL</th> <th>MIN</th> <th>NOM</th> <th>MAX</th> </tr> </thead> <tbody> <tr> <td>TOTAL THICKNESS</td> <td>A</td> <td>0.800</td> <td>0.850</td> <td>0.900</td> </tr> <tr> <td>STAND OFF</td> <td>A1</td> <td>0.000</td> <td>0.035</td> <td>0.050</td> </tr> <tr> <td rowspan="2">BODY SIZE</td> <td>X</td> <td>D</td> <td>7.000</td> <td>BSC</td> </tr> <tr> <td>Y</td> <td>E</td> <td>5.000</td> <td>BSC</td> </tr> <tr> <td rowspan="2">EP SIZE</td> <td>X</td> <td>J</td> <td>3.400</td> <td>3.500</td> <td>3.600</td> </tr> <tr> <td>Y</td> <td>K</td> <td>1.400</td> <td>1.500</td> <td>1.600</td> </tr> <tr> <td>LEAD WIDTH</td> <td>b</td> <td>1.350</td> <td>1.400</td> <td>1.450</td> </tr> <tr> <td rowspan="2">LEAD LENGTH</td> <td>L</td> <td>0.850</td> <td>0.900</td> <td>0.950</td> </tr> <tr> <td>L1</td> <td></td> <td>1.000</td> <td>REF</td> </tr> <tr> <td>LEAD PITCH</td> <td>e</td> <td></td> <td>2.540</td> <td>BSC</td> </tr> <tr> <td>PACKAGE TOLERANCE</td> <td>aaa</td> <td></td> <td>0.100</td> <td></td> </tr> <tr> <td>MOLD FLATNESS</td> <td>bbb</td> <td></td> <td>0.100</td> <td></td> </tr> <tr> <td>COPLANARITY</td> <td>ccc</td> <td></td> <td>0.080</td> <td></td> </tr> <tr> <td>DIMPLE WIDTH</td> <td>T</td> <td></td> <td>0.300</td> <td>REF</td> </tr> <tr> <td>DIMPLE LENGTH</td> <td>P</td> <td></td> <td>0.150</td> <td>REF</td> </tr> <tr> <td>DIMPLE DEPTH</td> <td>A2</td> <td></td> <td>0.100</td> <td>REF</td> </tr> </tbody> </table> <p>Notes 1. Dimensioning and tolerancing conform to ASME Y14.5-2009 2. All dimensions are in millimeters</p> <table border="1" style="width:100%; border-collapse: collapse; margin-top: 10px;"> <thead> <tr> <th colspan="2" style="text-align: center;">Package Outline</th> </tr> </thead> <tbody> <tr> <td style="text-align: center;">6L PQFV</td> <td style="text-align: center;">PCD-PQFV-006-C07030-037</td> </tr> <tr> <td style="text-align: center;">5.000x7.000x0.850 mm</td> <td style="text-align: center;"></td> </tr> <tr> <td style="text-align: center;">2019/03/13 Rev B00</td> <td></td> </tr> </tbody> </table>		SYMBOL	MIN	NOM	MAX	TOTAL THICKNESS	A	0.800	0.850	0.900	STAND OFF	A1	0.000	0.035	0.050	BODY SIZE	X	D	7.000	BSC	Y	E	5.000	BSC	EP SIZE	X	J	3.400	3.500	3.600	Y	K	1.400	1.500	1.600	LEAD WIDTH	b	1.350	1.400	1.450	LEAD LENGTH	L	0.850	0.900	0.950	L1		1.000	REF	LEAD PITCH	e		2.540	BSC	PACKAGE TOLERANCE	aaa		0.100		MOLD FLATNESS	bbb		0.100		COPLANARITY	ccc		0.080		DIMPLE WIDTH	T		0.300	REF	DIMPLE LENGTH	P		0.150	REF	DIMPLE DEPTH	A2		0.100	REF	Package Outline		6L PQFV	PCD-PQFV-006-C07030-037	5.000x7.000x0.850 mm		2019/03/13 Rev B00		<p>7.0 x 5.0 x 0.85 mm^[10]</p> <p>Note: Circles in center pad are thermal vias, recommended to improve thermal performance</p>
	SYMBOL	MIN	NOM	MAX																																																																																									
TOTAL THICKNESS	A	0.800	0.850	0.900																																																																																									
STAND OFF	A1	0.000	0.035	0.050																																																																																									
BODY SIZE	X	D	7.000	BSC																																																																																									
	Y	E	5.000	BSC																																																																																									
EP SIZE	X	J	3.400	3.500	3.600																																																																																								
	Y	K	1.400	1.500	1.600																																																																																								
LEAD WIDTH	b	1.350	1.400	1.450																																																																																									
LEAD LENGTH	L	0.850	0.900	0.950																																																																																									
	L1		1.000	REF																																																																																									
LEAD PITCH	e		2.540	BSC																																																																																									
PACKAGE TOLERANCE	aaa		0.100																																																																																										
MOLD FLATNESS	bbb		0.100																																																																																										
COPLANARITY	ccc		0.080																																																																																										
DIMPLE WIDTH	T		0.300	REF																																																																																									
DIMPLE LENGTH	P		0.150	REF																																																																																									
DIMPLE DEPTH	A2		0.100	REF																																																																																									
Package Outline																																																																																													
6L PQFV	PCD-PQFV-006-C07030-037																																																																																												
5.000x7.000x0.850 mm																																																																																													
2019/03/13 Rev B00																																																																																													

Notes:

8. Top Marking: Y denotes manufacturing origin and XXXX denotes manufacturing lot number. The value of “Y” will depend on the assembly location of the device.
9. A capacitor of value 0.1 μF or higher between Vdd and GND is required. An additional 10 μF capacitor between Vdd and GND is required for the best phase jitter performance
10. The center pad has no electrical function. Soldering down the center pad to the GND is recommended for best thermal dissipation, but is optional.

Ordering Information

SiT9387AC-1B1-33E 322.265625T

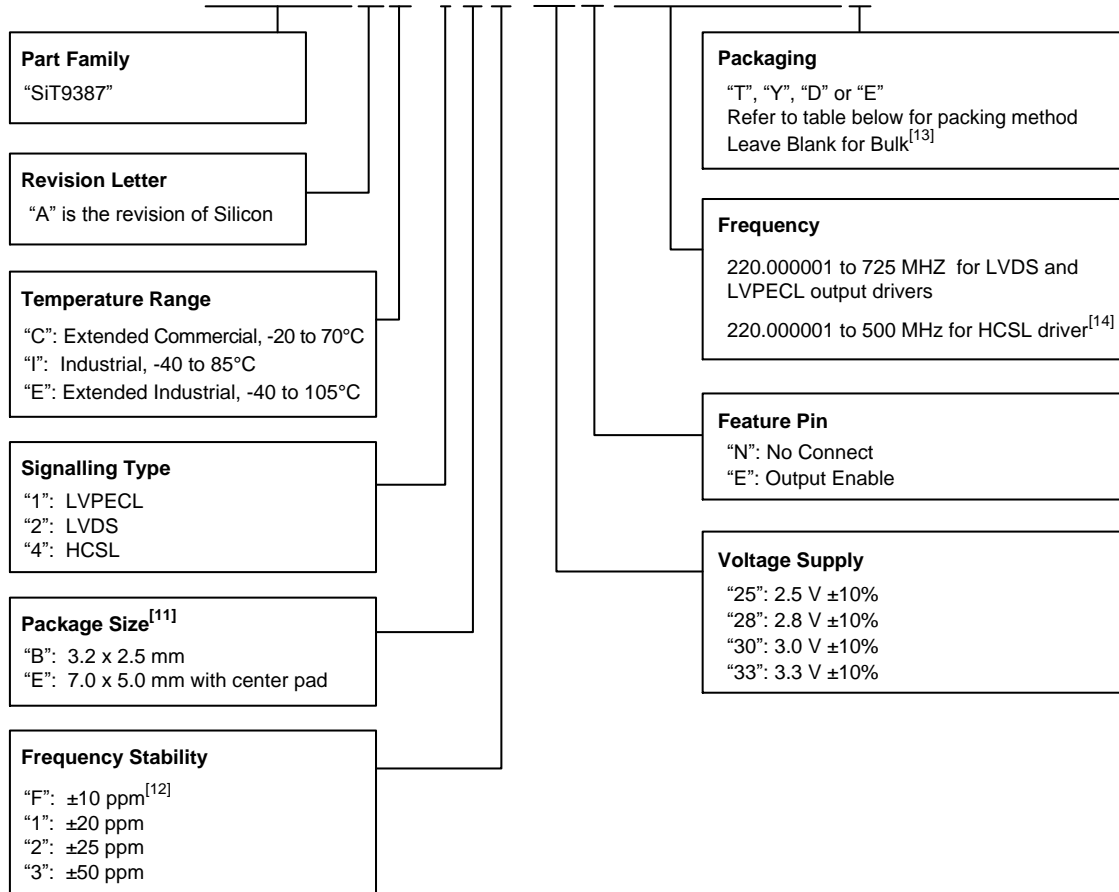

Notes:

- 11. [Contact SiTime](#) for 5.0 x 3.2 mm package.
- 12. [Contact SiTime](#) for ±10 ppm option.
- 13. Bulk is available for sampling only.
- 14. [Contact SiTime](#) for higher frequency HCSL options.

Table 10. Ordering Codes for Supported Tape & Reel Packing Method

Device Size (mm x mm)	8 mm T&R (3ku)	8 mm T&R (1ku)	12 mm T&R (3ku)	12 mm T&R (1ku)	16 mm T&R (3ku)	16 mm T&R (1ku)
7.0 x 5.0	—	—	—	—	T	Y
3.2 x 2.5	D	E	—	—	—	—

Table 11. Additional Information

Document	Description	Download Link
ECCN #: EAR99	Five character designation used on the commerce Control List (CCL) to identify dual use items for export control purposes.	—
Part number Generator	Tool used to create the part number based on desired features.	—
Manufacturing Notes	Tape & Reel dimension, reflow profile and other manufacturing related info	http://www.sitime.com/manufacturing-notes
Qualification Reports	RoHS report, reliability reports, composition reports	http://www.sitime.com/support/quality-and-reliability
Performance Reports	Additional performance data such as phase noise, current consumption and jitter for selected frequencies	http://www.sitime.com/support/performance-measurement-report
Termination Techniques	Termination design recommendations	http://www.sitime.com/support/application-notes
Layout Techniques	Layout recommendations	http://www.sitime.com/support/application-notes

Table 12 .Revision History

Revision	Release Date	Change Summary
0.1	03/11/2017	Initial draft
0.87	11/06/2017	Updated package drawings Corrected tape/reel ordering information Updated Electrical Characteristics based on characterization Added additional information table Corrected formatting issues added temperature range to 105°C Changed ±10 ppm to “contact SiTime” Updated termination diagrams Lower mechanical shock from 20,000 to 10,000 <i>g</i>
0.90	11/24/2017	Ordering information updates and page layout changes
1.0	03/15/2019	Updated Electrical Characteristics tables Updated waveform diagrams Added OE enable/disable timing diagrams Updated package dimensions Added an AEC-Q100 Grade 4 temperature option Updated the ordering information

SiTime Corporation, 5451 Patrick Henry Drive, Santa Clara, CA 95054, USA | **Phone:** +1-408-328-4400 | **Fax:** +1-408-328-4439

© SiTime Corporation 2017-2019. The information contained herein is subject to change at any time without notice. SiTime assumes no responsibility or liability for any loss, damage or defect of a Product which is caused in whole or in part by (i) use of any circuitry other than circuitry embodied in a SiTime product, (ii) misuse or abuse including static discharge, neglect or accident, (iii) unauthorized modification or repairs which have been soldered or altered during assembly and are not capable of being tested by SiTime under its normal test conditions, or (iv) improper installation, storage, handling, warehousing or transportation, or (v) being subjected to unusual physical, thermal, or electrical stress.

Disclaimer: SiTime makes no warranty of any kind, express or implied, with regard to this material, and specifically disclaims any and all express or implied warranties, either in fact or by operation of law, statutory or otherwise, including the implied warranties of merchantability and fitness for use or a particular purpose, and any implied warranty arising from course of dealing or usage of trade, as well as any common-law duties relating to accuracy or lack of negligence, with respect to this material, any SiTime product and any product documentation. Products sold by SiTime are not suitable or intended to be used in a life support application or component, to operate nuclear facilities, or in other mission critical applications where human life may be involved or at stake. All sales are made conditioned upon compliance with the critical uses policy set forth below.

CRITICAL USE EXCLUSION POLICY

BUYER AGREES NOT TO USE SITIME'S PRODUCTS FOR ANY APPLICATION OR IN ANY COMPONENTS USED IN LIFE SUPPORT DEVICES OR TO OPERATE NUCLEAR FACILITIES OR FOR USE IN OTHER MISSION-CRITICAL APPLICATIONS OR COMPONENTS WHERE HUMAN LIFE OR PROPERTY MAY BE AT STAKE.

SiTime owns all rights, title and interest to the intellectual property related to SiTime's products, including any software, firmware, copyright, patent, or trademark. The sale of SiTime products does not convey or imply any license under patent or other rights. SiTime retains the copyright and trademark rights in all documents, catalogs and plans supplied pursuant to or ancillary to the sale of products or services by SiTime. Unless otherwise agreed to in writing by SiTime, any reproduction, modification, translation, compilation, or representation of this material shall be strictly prohibited.