

SiT1569

µPower, Ultra-Small 1 Hz – 462.5 kHz ±50 ppm Oscillator



Features

- µPower operating current: 3.3 µA (100 kHz)
- Factory-programmable frequency from 1 Hz to 462.5 kHz^[1]
- ±50 ppm max all-inclusive frequency stability
- World's smallest oscillator footprint: 1.2 mm²
- 1.5 mm x 0.8 mm CSP
- 0.6 mm max height
- No external bypass capacitors required
- Wide operating supply voltage range: 1.8V to 3.3V
- LVCMOS compatible output
- Pb-free, RoHS and REACH compliant

Applications

- Smart stylus
- Wearable biometric sensing
- Wireless chargers
- Portable medical



Note:

1. For higher frequency applications, consider the [SiT1576](#) or the [SiT8021](#).

Electrical Specifications

Table 1. DC Electrical Characteristics^[2]

Conditions: Min/Max limits are over temperature, $V_{DD} = 1.8V \pm 10\%$, unless otherwise stated. Typicals are at 25°C and $V_{DD} = 1.8V$.

Parameters	Symbol	Min.	Typ.	Max.	Unit	Condition
Frequency						
Output Frequency Range	F_{OUT}	1.0		462.5 k	Hz	
Frequency Stability						
Initial Tolerance	F_{tol}	-10		10	ppm	$T_A = 25^\circ C$. Includes 2x reflow.
Frequency Stability	F_{stab}	-50		50	ppm	All inclusive of over temperature, referenced to nominal frequency at 25°C, inclusive of V_{DD} , aging, and load
Jitter						
RMS Period Jitter	t_{jitter}		4	8.5	ns _{RMS}	10,000 cycles, per JEDEC standard 65B, tested at 100 kHz
Power Supply						
Power Supply Voltage	V_{DD}	1.62		3.63	V	
No Load Supply Current	I_{DD}		1.7	3	µA	$F_{OUT} = 1$ Hz
			3.3	4.6		$F_{OUT} = 100$ kHz
			8	10		$F_{OUT} = 462.5$ kHz
Start-up Time	t_{start}		150	300	ms	$F_{OUT} > 200$ Hz, to first output pulse.
			250 + 2.0 cycles	300 + 2.5 Cycles		10 Hz < $F_{OUT} \leq 200$ Hz, to first output pulse.
				500 + 2.5 Cycles		1 Hz ≤ $F_{OUT} \leq 10$ Hz, to first output pulse.
Operating Temperature Range						
Commercial Temperature		-20		70	°C	
Industrial Temperature		-40		85	°C	
LVCMOS Output						
Rise-Fall Time	t_{R}/t_F	10	40	70	ns	20-80%, 15 pF load, $V_{DD} = 1.8V \pm 10\%$
Output Clock Duty Cycle	DC	45		55	%	
V_{OH} - Output Voltage High	V_{OH}	90%				$I_{OH} = -50$ µA, 15 pF load
V_{OL} - Output Voltage Low	V_{OL}			10%		$I_{OL} = 50$ µA, 15 pF load

Note:

2. For applications requiring lower jitter or improved frequency stability, consider the [SiT1579](#), or contact [SiTime](#) for other product options.

Table 2. Pin Configuration

Pin	Symbol	I/O	Functionality
1	NC	Internal Test Pin	No Connect. Leave floating. Pin 1 is for internal testing and is designed to be left floating.
2	CLK Out	Output	Oscillator clock output, LVCMOS compatible
3	V _{DD}	Power Supply	Connect to power supply between 1.8V and 3.3V \pm 10%. Under normal operating conditions, V _{DD} does not require external bypass/decoupling capacitor(s). The SiT1569 includes on-chip V _{DD} filtering.
4	GND	Power Supply Ground	Connect to GND

CSP Package (Top View)

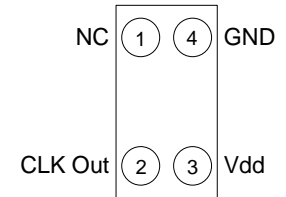

Figure 1. Pin Assignments

Table 3. Absolute Maximum Ratings

Attempted operation outside the absolute maximum ratings may cause permanent damage to the part. Actual performance of the IC is only guaranteed within the operational specifications, not at absolute maximum ratings.

Parameters	Test Conditions	Value	Unit
Continuous Power Supply Voltage Range (V _{DD})		-0.5 to 4.0	V
Continuous Maximum Operating Temperature Range		105	°C
Short Duration Maximum Operating Temperature Range	\leq 30 minutes	125	°C
Human Body Model (HBM) ESD Protection	JESD22-A114	2000	V
Charge-Device Model (CDM) ESD Protection	JESD22-C101	750	V
Machine Model (MM) ESD Protection	JESD22-A115	200	V
Latch-up Tolerance	JESD78 Compliant		
Mechanical Shock Resistance	Mil 883, Method 2002	20,000	g
Mechanical Vibration Resistance	Mil 883, Method 2007	70	g
1508 CSP Junction Temperature		150	°C
Storage Temperature		-65 to 150	°C

System Block Diagram

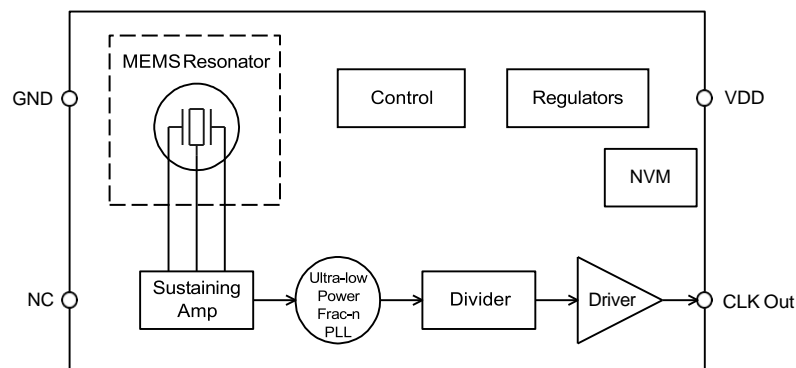

Figure 2. SiT1569 Block Diagram

Detailed Description

The SiT1569 is the first ULP, factory-programmable oscillator in an ultra-small 1.5mm x 0.8mm (1508) chip-scale package (CSP), and part of a new family of ULP, ultra-small oscillators from SiTime. This device can be programmed for any frequency between 1 Hz and 462.5 kHz. The silicon MEMS technology makes it possible to produce the world's smallest, programmable reference clock in a chip-scale package.

SiTime's MEMS oscillator consists of a MEMS resonator and a programmable analog circuit. SiT1569 MEMS resonator is built with SiTime's unique MEMS First™ process. A key manufacturing step is EpiSeal™ during which the MEMS resonator is annealed with temperatures over 1000°C.

EpiSeal creates an extremely strong, clean, vacuum chamber that encapsulates the MEMS resonator and ensures the best performance and reliability. During EpiSeal, a poly silicon cap is grown on top of the resonator cavity, which eliminates the need for additional cap wafers or other exotic packaging. As a result, SiTime's MEMS resonator die can be used like any other semiconductor die. One unique result of SiTime's MEMS First and EpiSeal manufacturing processes is the capability to integrate SiTime's MEMS die with a SOC, ASIC, microprocessor or analog die within a package to eliminate external timing components and provide a highly integrated, smaller, more cost-effective solution to the customer.

Frequency Stability

The SiT1569 oscillator is Factory trimmed to 32.768 kHz at room temperature. The result is a very accurate oscillator at room temperature and over temperature. Unlike quartz crystals that have a classic tuning fork parabola temperature curve with a 25°C turnover point with a 0.04 to 0.06 ppm/°C² temperature coefficient (TCF), the SiT1569 temperature coefficient is calibrated at room temperature and corrected over temperature with an active temperature correction circuit. The result is \leq ±50 ppm frequency variation over the -40°C to +85°C temperature range.

When measuring the SiT1569 output frequency with a frequency counter, it is important to make sure the counter's gate time is >100 ms. Shorter gate times may lead to inaccurate measurements.

Typical Operating Curves

($T_A = 25^\circ\text{C}$, $V_{DD} = 1.8\text{V}$, supply current plots are no load, unless otherwise stated)

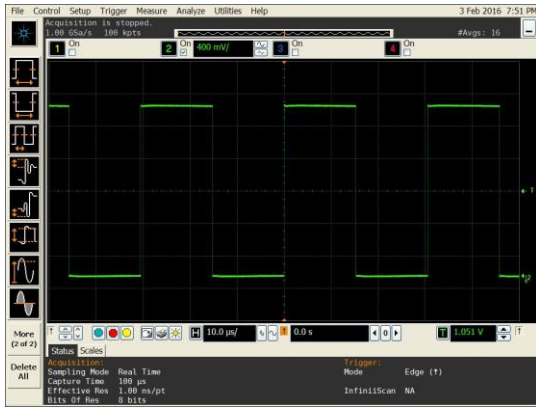

Figure 3. LVC MOS Output Swing ($V_{DD} = 1.8\text{V}$)

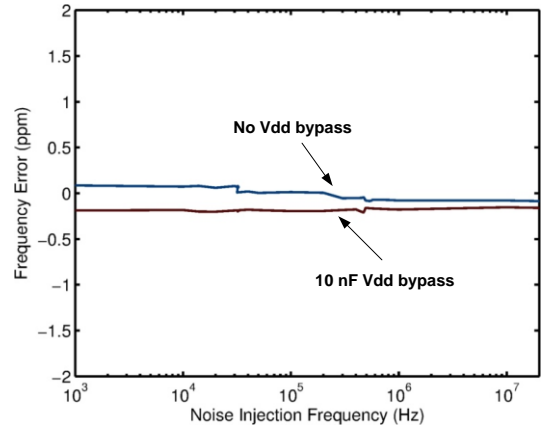

Figure 4. Power Supply Noise Rejection (PSNR)

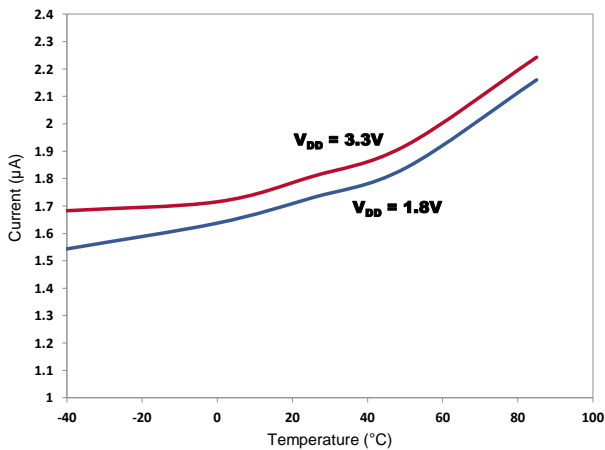

Figure 5. Supply Current vs Temperature ($F_{OUT} = 1\text{Hz}$)

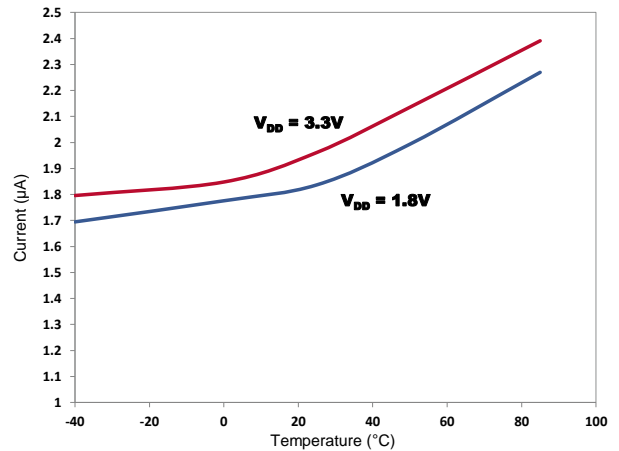

Figure 6. Supply Current vs Temperature ($F_{OUT} = 100\text{Hz}$)

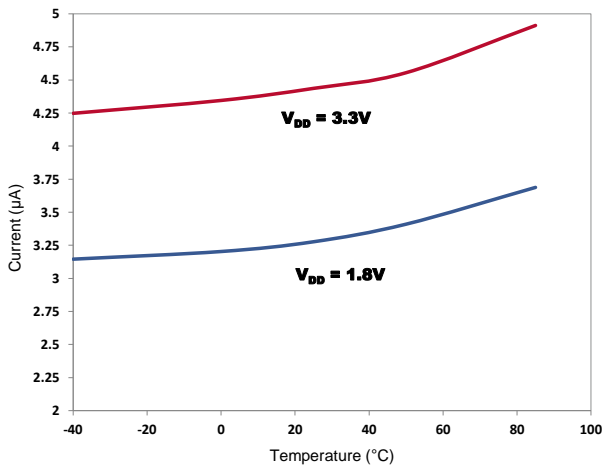

Figure 7. Supply Current vs Temperature ($F_{OUT} = 100\text{kHz}$)

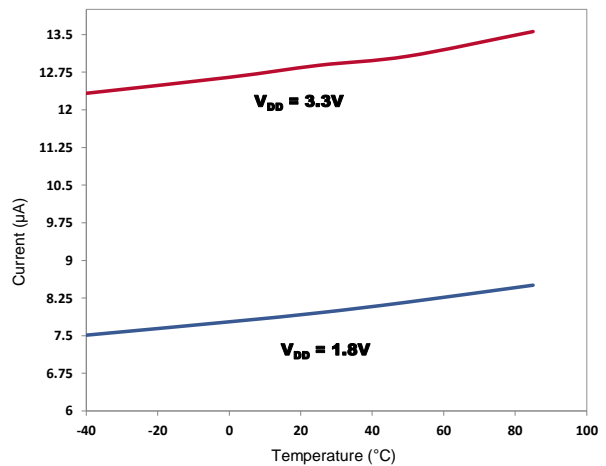
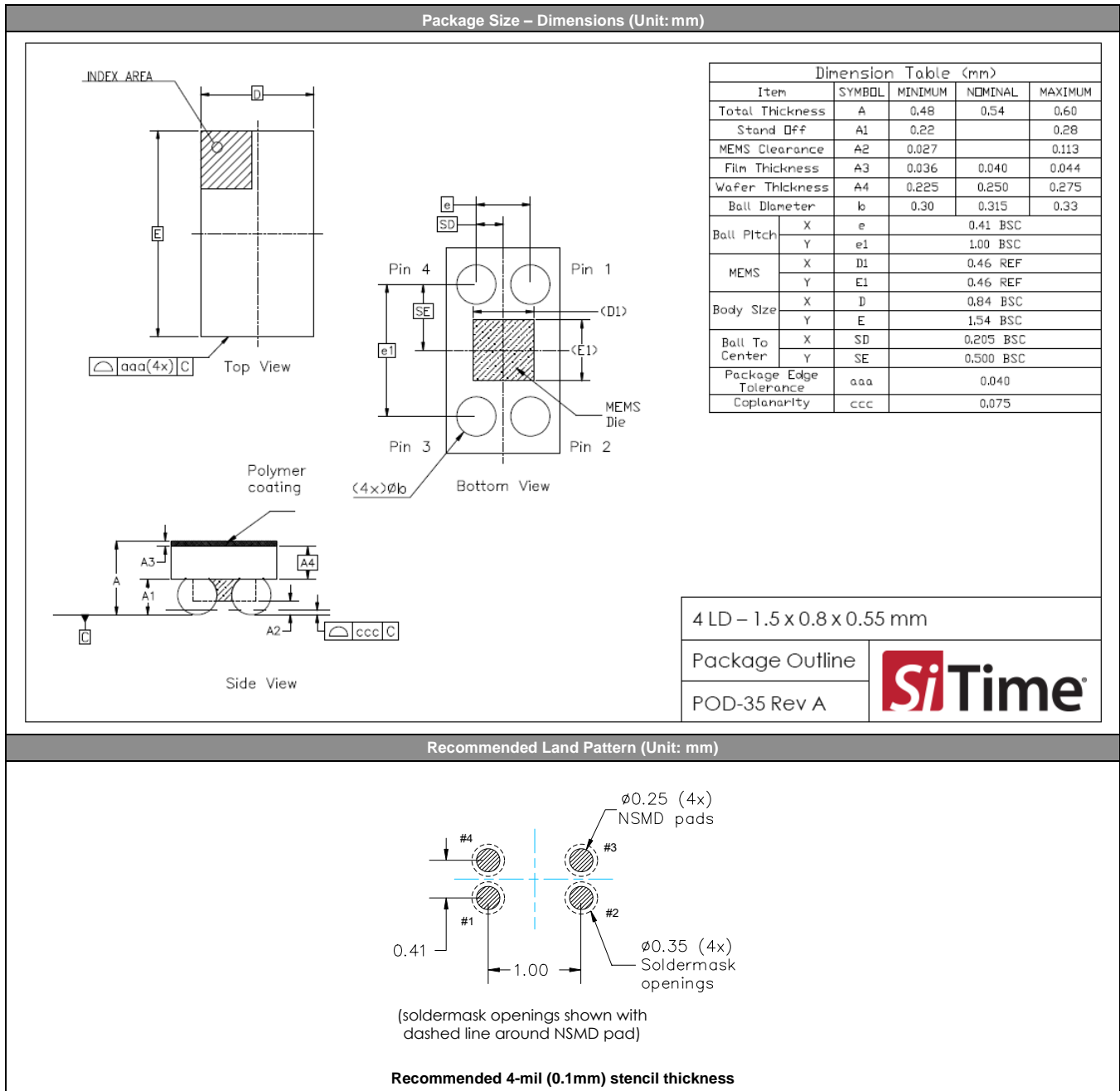

Figure 8. Supply Current vs Temperature ($F_{OUT} = 440\text{kHz}$)

Dimensions and Patterns



Manufacturing Guidelines

- 1) No Ultrasonic or Megasonic cleaning: Do not subject the SiT1569 to an ultrasonic or megasonic cleaning environment. Permanent damage or long term reliability issues may occur.
- 2) Applying board-level underfill and overmold is acceptable and will not impact the reliability of the device.
- 3) Reflow profile, per JESD22-A113D.
- 4) The SiT1569 CSP includes a protective, opaque polymer top-coat. If the SiT1569 will see intense light, especially in the 1.0-1.2 μ m IR spectrum, we recommend a protective “glob-top” epoxy or other cover to keep the light from negatively impacting the frequency stability.
- 5) For additional manufacturing guidelines and marking/tape-reel instructions, refer to [SiTime Manufacturing Notes](#).

Ordering Information

SiT1569AC-J3-33E-0000.000000Q

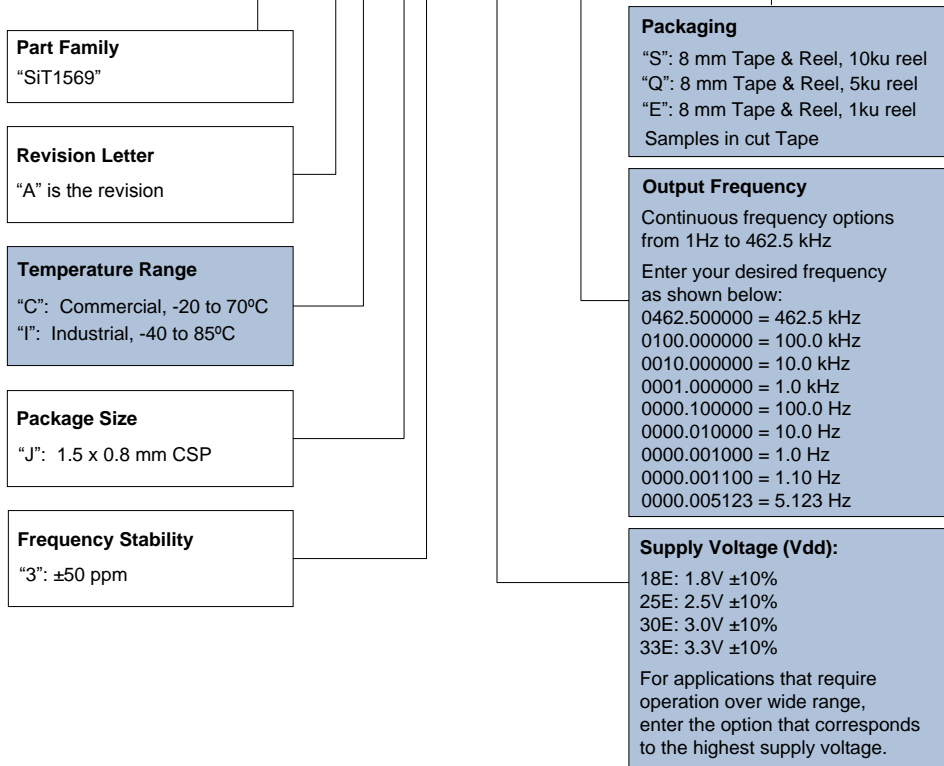

Table 4. Revision History

Version	Release Date	Change Summary
0.25	01/13/2016	Initial Preliminary
0.5	04/28/2016	Updated max operating frequency Updated part number ordering
0.7	07/08/2016	Updated min/max frequency stability, added RMS period jitter
0.9	04/28/2017	Update part numbering code Update min/max frequency stability Updated CSP package outline drawing (POD) Updated Supply Current max limits Updated logo and company address, other page layout changes
1.0	05/10/2017	Final Release
1.1	05/17/2018	Added additional typical operating curves Updated typical No Load Supply Current (Table 1) Corrected frequency range from '1 HZ – 460 KHz' to '1 HZ – 462.5 KHz'

SiTime Corporation, 5451 Patrick Henry Drive, Santa Clara, CA 95054, USA | Phone: +1-408-328-4400 | Fax: +1-408-328-4439

© SiTime Corporation 2016-2018. The information contained herein is subject to change at any time without notice. SiTime assumes no responsibility or liability for any loss, damage or defect of a Product which is caused in whole or in part by (i) use of any circuitry other than circuitry embodied in a SiTime product, (ii) misuse or abuse including static discharge, neglect or accident, (iii) unauthorized modification or repairs which have been soldered or altered during assembly and are not capable of being tested by SiTime under its normal test conditions, or (iv) improper installation, storage, handling, warehousing or transportation, or (v) being subjected to unusual physical, thermal, or electrical stress.

Disclaimer: SiTime makes no warranty of any kind, express or implied, with regard to this material, and specifically disclaims any and all express or implied warranties, either in fact or by operation of law, statutory or otherwise, including the implied warranties of merchantability and fitness for use or a particular purpose, and any implied warranty arising from course of dealing or usage of trade, as well as any common-law duties relating to accuracy or lack of negligence, with respect to this material, any SiTime product and any product documentation. Products sold by SiTime are not suitable or intended to be used in a life support application or component, to operate nuclear facilities, or in other mission critical applications where human life may be involved or at stake. All sales are made conditioned upon compliance with the critical uses policy set forth below.

CRITICAL USE EXCLUSION POLICY

BUYER AGREES NOT TO USE SITIME'S PRODUCTS FOR ANY APPLICATION OR IN ANY COMPONENTS USED IN LIFE SUPPORT DEVICES OR TO OPERATE NUCLEAR FACILITIES OR FOR USE IN OTHER MISSION-CRITICAL APPLICATIONS OR COMPONENTS WHERE HUMAN LIFE OR PROPERTY MAY BE AT STAKE.

SiTime owns all rights, title and interest to the intellectual property related to SiTime's products, including any software, firmware, copyright, patent, or trademark. The sale of SiTime products does not convey or imply any license under patent or other rights. SiTime retains the copyright and trademark rights in all documents, catalogs and plans supplied pursuant to or ancillary to the sale of products or services by SiTime. Unless otherwise agreed to in writing by SiTime, any reproduction, modification, translation, compilation, or representation of this material shall be strictly prohibited.