

# 規格承認書

## PECIFICATION FOR APPROVAL

客戶  
CUSTOMER : 通用型規格書 电压范围 3-60V  
項目  
ITEM : 压电有源蜂鸣器 (内含驱动电路)  
型號  
TYPE : GPD4219L100-3-60V3200-J 报警声  
描述  
DESCRIPTION :  $\Phi$ 42.0 x H18.8 mm 3000Hz DC3-60V 1.5S  $\geq$ 90DB at 10cm L=100 mm  
客戶料號  
CUSTOMER NO. :  
規格書號  
SPECIFICATION NO.:  
版本  
EDITION NO. : V1.0  
日期  
DATE : 20

### 客戶承認

#### CUSTOMER CONFIRM AND SIGN

檢查 TESTED BY	審核 CHECKED BY	承認 APPROVED BY

### 東莞市贏海電子有限公司

#### DONGUAN INGHAI ELECTRONICS CO.,LTD

製作 ISSUED BY	審查 CHECKED BY	確認 APPROVED BY
周明	陈铭	

地址：廣東省東莞市長安鎮廈邊元灶頭工業區 16-6 號

電話 / TEL: 0769-83060958 傳真 / FAX: 0769-81608993

網址: [HTTP://WWW.INGHAI.COM](http://www.inghai.com)

# DONGGUAN INGHAI ELECTRONICS CO.,LTD

Model NO: GPD4219L100-3-60V3200-J 报警声

A: DIMENSIONS Unit:mm Tolerance:  $\pm 0.5$  线长 L100mm

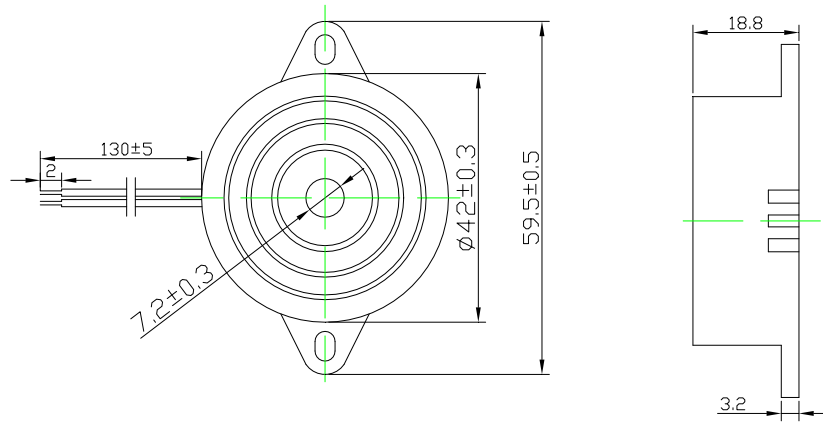

## B: SPECIFICATIONS

Model NO	GPD4219L100
Rated Voltage	3-60VDC
Operating Voltage	3-60VDC
Max.Rated Current	Max.50mA
Sound Pressure level(dB/min) at 10cm	Min.90dB/1.5S
Resonant Frequency	3000 $\pm$ 500Hz
Operating Temperature	-20 °C ~ +60 °C
Storage Temperature	-30 °C ~ +70 °C
Case material and color	ABS / Black

### Measuring condition

Part shall be measured under a condition (Temperature: 5 ~ 35°C, Humidity: 45% ~ 85%R.H., Atmospheric pressure: 860 ~ 1060hPa) unless the standard condition (Temperature: 25 $\pm$ 3°C, Humidity: 60 $\pm$ 10%R.H. Atmospheric pressure: 860 ~ 1060hPa) is regulated to measure.

## C: Reliability Test

After any following tests the part shall meet specifications without any degradation in appearance and performance except SPL. SPL shall not deviate more than -10 dB from the initial value

### 1. Ordinary Temperature Life Test

The part shall be subjected to 96 hours at  $25 \pm 10^\circ\text{C}$ . Input rated voltage Resonant frequency, 1/2 duty Square wave.

### 2. High Temperature Test

The part shall be capable of with standing a storage temperature of  $+70^\circ\text{C}$  for 96 hours.

### 3. Low Temperature Test

The part shall be capable of with standing a storage temperature of  $-30^\circ\text{C}$  for 96 hours.

### 4. Humidity Test

Temperature:  $+40^\circ\text{C} \pm 3^\circ\text{C}$  Relative Humidity: 90% ~ 95% Duration: 48 hours and expose to room temperature for 6 hours

### 5. Temperature Shock Test

Temperature:  $60^\circ\text{C}$  /1hour →  $25^\circ\text{C}$ /3hours →  $-30^\circ\text{C}$ /1hour →  $25^\circ\text{C}$ /3hours (1cycle)  
Total cycle: 10 cycles

### 6. Drop Test

Standard Packaging From 120mm (Drop on hard wood or board of 5cm thick, three sides, six plain.)

### 7. Vibration Test

Vibration: 1000cycles /min. Amplitude: 1.5mm, Duration: 1 hour in each 3 axes

### Note:

As this product is not protected from foreign material entering, please make sure that any foreign materials (e.g. magnetic powder, washing solvent, flux, corrosive gas) do not enter this product in your production processes. The functional degradation (e.g. SPL down) may occur if foreign material enter it.