

規格承認書

PECIFICATION FOR APPROVAL

客戶

CUSTOMER : 通用型規格書 电压范围 3-24V

項目

ITEM : 压电有源蜂鸣器 (内含驱动电路)

型號

TYPE : **GPD2615L100-3-24V3500** 线长可定制

描述

DESCRIPTION : Φ 2615 x H17 mm 400Hz 3-24V \geq 80DB ABS 材质 L=100 mm

客戶料號

CUSTOMER NO. :

規格書號

SPECIFICATION NO.:

版本

EDITION NO. : V1.0

日期

DATE : 2

客戶承認

CUSTOMER CONFIRM AND SIGN

檢查 TESTED BY	審核 CHECKED BY	承認 APPROVED BY

東莞市贏海電子有限公司

DONGUAN INGHAI ELECTRONICS CO.,LTD

製作 ISSUED BY	審查 CHECKED BY	確認 APPROVED BY
周明	刘承成	

地址：广东省东莞市长安镇上沙第五工业区新春路 1 号新春科技园 1001 号

電話 / TEL: 0769-83060958 傳真 / FAX: 0769-81608993

網址: [HTTP://WWW.INGHAI.COM](http://www.inghai.com)

DONGGUAN INGHAI ELECTRONICS CO.,LTD

Model NO: GPD2615L100-3-24V3500

A: DIMENSIONS Unit:mm Tolerance: ± 0.5

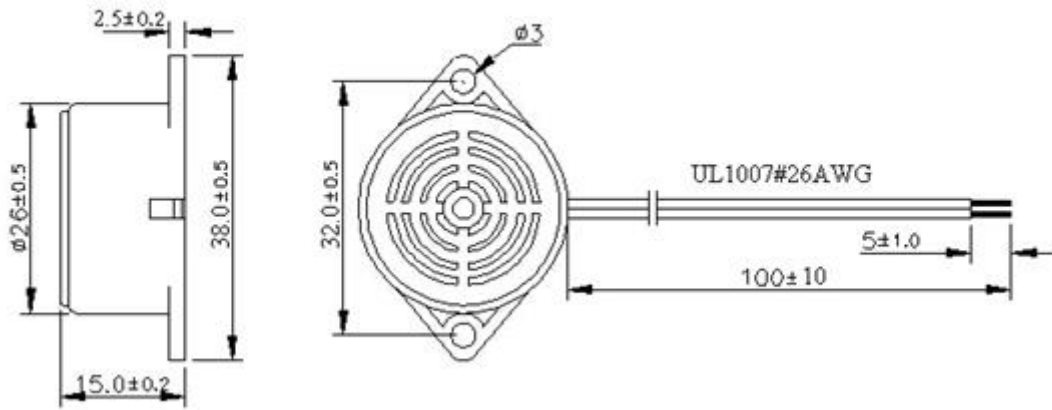

B: SPECIFICATIONS

Model NO	GPD2615L100-3-24V3500
Rated Voltage	3-24VDC
Operating Voltage	3-26VDC
Max.Rated Current	Max.25mA
Sound Pressure level(dB/min) at 30cm	Min.80dB
Resonant Frequency	400 ± 100 Hz
Operating Temperature	-20 °C~+60 °C
Storage Temperature	-30 °C~+70 °C
Case material and color	ABS / Black

Measuring condition

Part shall be measured under a condition (Temperature: 5 ~ 35°C, Humidity: 45% ~ 85%R.H., Atmospheric pressure: 860 ~ 1060hPa) unless the standard condition (Temperature: 25 \pm 3°C, Humidity: 60 \pm 10%R.H. Atmospheric pressure: 860 ~ 1060hPa) is regulated to measure.

C: Acoustic Characteristics:

The oscillation frequency, current consumption and sound pressure are measured by the measuring instruments shown below

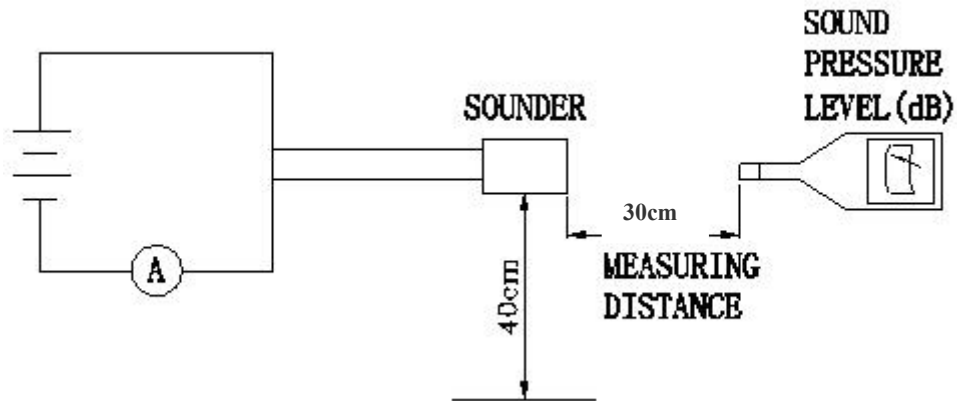

In the measuring test, buzzer is placed as follows:

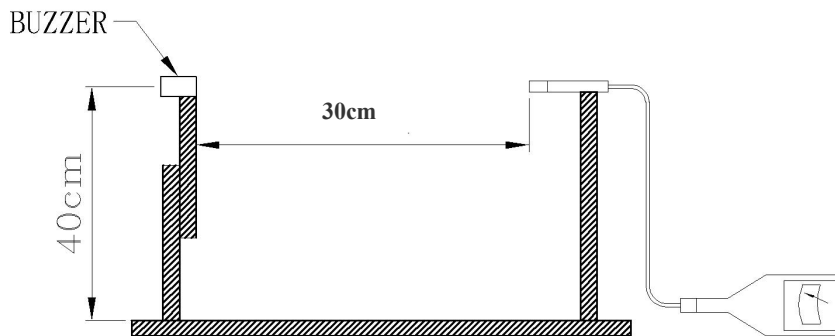

D: VOLTAGE / CURRENT / SOUND PRESSURE CHARACTERISTICS

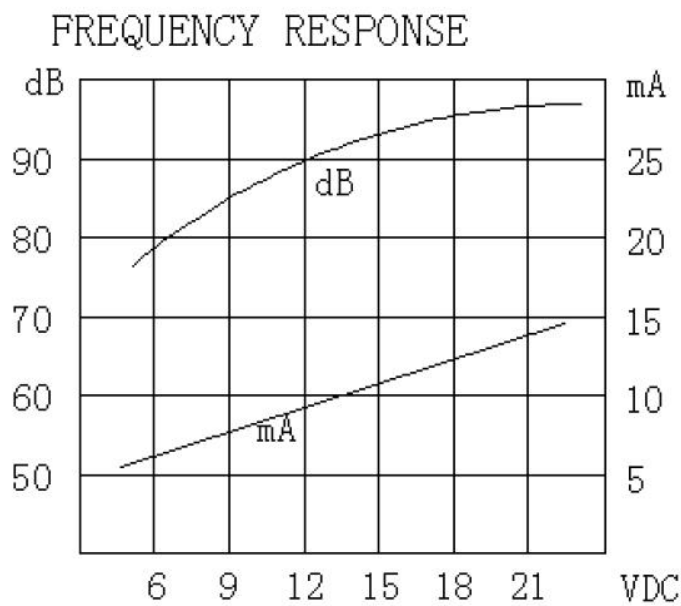

E: Reliability Test

After any following tests the part shall meet specifications without any degradation in appearance and performance except SPL. SPL shall not deviate more than -10 dB from the initial value

1. Ordinary Temperature Life Test

The part shall be subjected to 96 hours at $25 \pm 10^\circ\text{C}$. Input rated voltage Resonant frequency, 1/2 duty Square wave.

2. High Temperature Test

The part shall be capable of with standing a storage temperature of $+70^\circ\text{C}$ for 96 hours.

3. Low Temperature Test

The part shall be capable of with standing a storage temperature of -30°C for 96 hours.

4. Humidity Test

Temperature: $+40^\circ\text{C} \pm 3^\circ\text{C}$ Relative Humidity: 90% ~ 95% Duration: 48 hours and expose to room temperature for 6 hours

5. Temperature Shock Test

Temperature: 60°C /1hour \rightarrow 25°C /3hours \rightarrow -30°C /1hour \rightarrow 25°C /3hours (1cycle)
Total cycle: 10 cycles

6. Drop Test

Standard Packaging From 120mm (Drop on hard wood or board of 5cm thick, three sides, six plain.)

7. Vibration Test

Vibration: 1000cycles /min. Amplitude: 1.5mm, Duration: 1 hour in each 3 axes

Note:

As this product is not protected from foreign material entering, please make sure that any foreign materials (e.g. magnetic powder, washing solvent, flux, corrosive gas) do not enter this product in your production processes. The functional degradation (e.g. SPL down) may occur if foreign material enter it.