

RoHS 2.0

REV.	ECN NO.	DESCRIPTION	DATE	DESIGN
A0		新版发行	20/04/08	Yang
A1		重新核对图面	20/12/29	LiHui

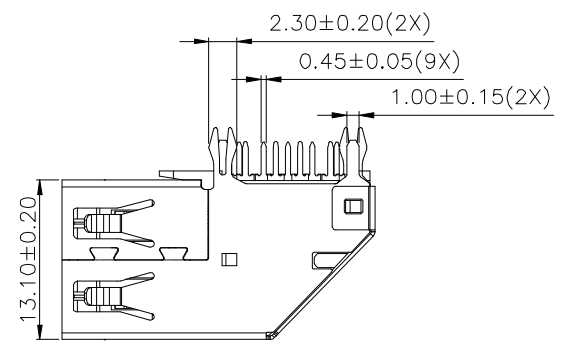
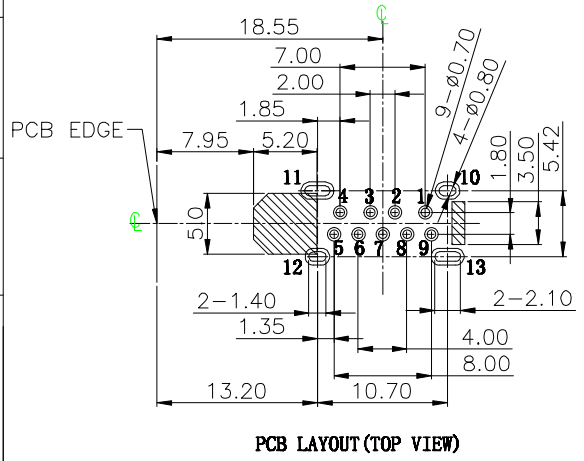
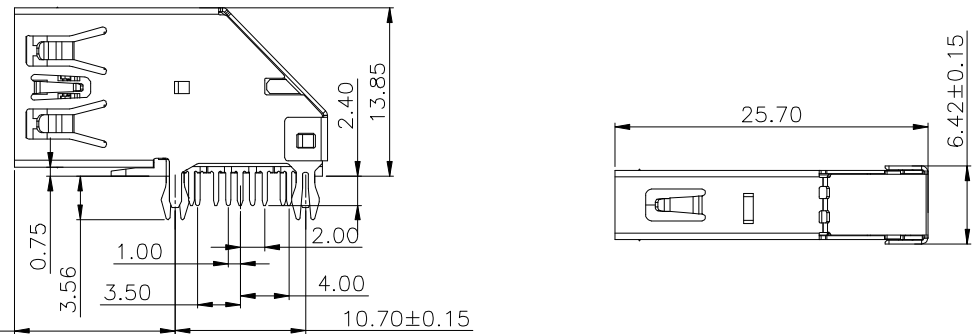
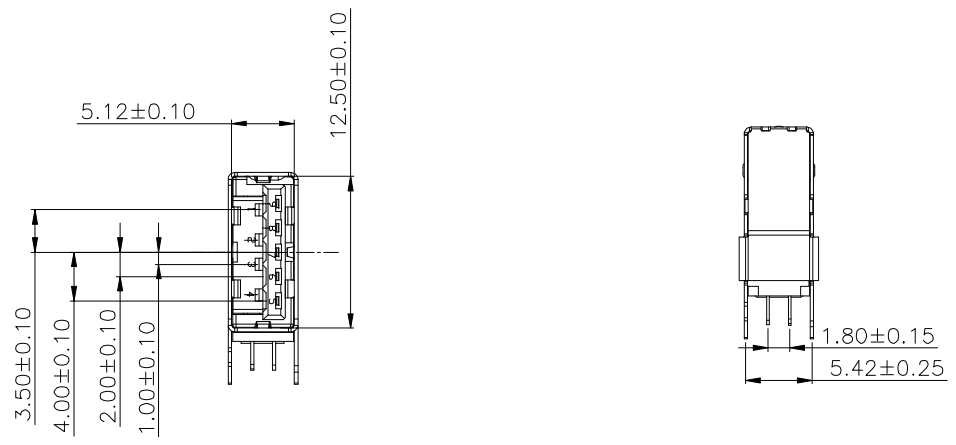

NOTES:

- MATERIAL:
 - HOUSING: LCP ,COLOR IS BLUE,HIGH TEMPERATURE PLASTIC;
 - CONTACT: BRASS(H65 T=0.20&0.25mm);
 - SHELL: COLD ROLLED IRON (SPCC T=0.30mm);
- ELECTRICAL:
 - VOLTAGE RATING: 30V DC ;
 - CURRENT RATING: 1.5A ;
 - CONTACT RESISTANCE: 30MILLIOHMS MAX.;
 - WITHSTAND VOLTAGE: 100V AC RMS 50(60)Hz,1MIN.;
 - INSULATION RESISTANCE: 100MEGOHMS MIN @500V DC;
- MECHANICAL:
 - MATING FORCE: 35N MAX.;
 - UNMATING FORCE: 5~35N ;
 - OPERATING LIFE: 1500 CYCLES MIN.;
- PLATING:
 - TERMINAL:
NI PLATING OVER ALL,
Tin PLATING ON SOLDER AREA,
Au G/Fu" ON CONTACT AREA;
 - SHELL: NI PLATING OVER ALL;
- ENVIRONMENTAL:
 - STORAGE TEMPERATURE RANGE: -40°C~+85°C;
 - OPERATION TEMPERATURE RANGE: -25°C~+70°C;

富港电子

UNLESS OTHERWISE SPECIFIED, GENERAL TOLERANCE: X.xxx ±0.10 X.xx ±0.20 X.x ±0.30 X ±0.35	NAME: 3.0 A母180° L13.7平口弯脚		P/M: ST-003-03-Z		
	THIRD ANGLE PROJECTION 	UNIT: MM	SCALE: 1:1	SIZE: A4	SHEET: 1/1
ANGULAR: X.xx° ±1° X.x° ±3° X° ±5°	DRAWN:		CHECKED:		APPROVED: