

Gas Discharge Tube (GDT) Data Sheet

Features

- Provide ultra-fast response to surge voltage from slow-rising surge of 100V/s to rapid-rising surge of 1KV/ μ s
- Stable breakdown voltage
- High insulation resistance
- Low capacitance (≤ 2 pF)
- High holdover voltage
- Large absorbing transient current capability
- Micro-Gap Design
- Size: 6.0mm*8.5mm
- Storage and operating temperature: $-40^{\circ}\text{C} \sim +85^{\circ}\text{C}$
- Meets MSL level 1, per J-STD-020
- Safety certification: E244458



Applications

- Repeaters, Modems
- Telephone Interface, Line cards
- Data communication equipment
- Line test equipment

Part Number Code

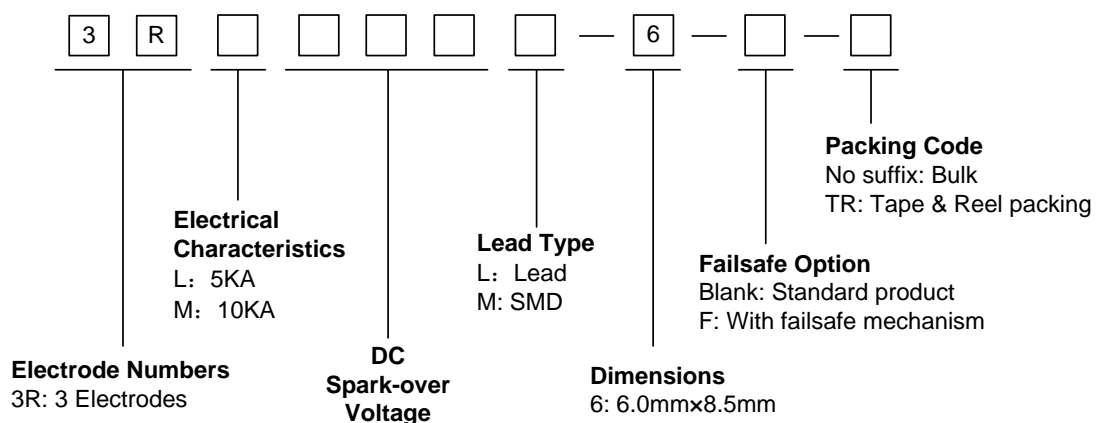

Marking

B : BrightKing Logo
 3RL090-6 : Device Marking Code
 YXXX : Date Code

Dimensions

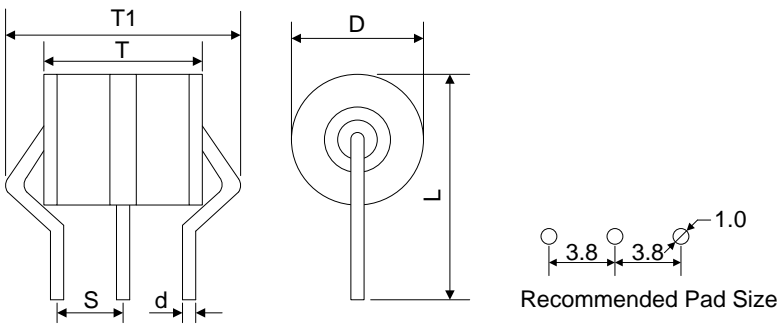
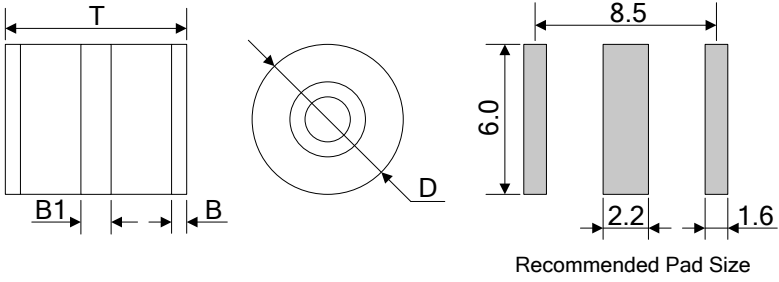
L Type	Symbol	Dimension (mm)	
		Spec.	Tolerance
	D	6.0	+0.2, -0.5
	T	8.5	±0.5
	T1	15.0	Max.
	L	16.0	Max.
L-F Type	S	3.8	±0.3
	d	0.8	±0.1
	R1	7.8	±0.4
	R2	6.3	±0.3
M Type	D	6.0	±0.2
	T	8.5	±0.5
	B	1.0	±0.1
	B1	1.5	±0.2
			

Electrical Characteristics

Part Number		DC Spark-over Voltage	Maximum Impulse Spark-over Voltage	Nominal Impulse Discharge Current	Alternating Discharge Current	Impulse Life	Minimum Insulation Resistance		Maximum Capacitance	Device Marking Code
		100V/s	1000V/ μ s	8/20 μ s 10times	50Hz, 1sec	10/1000 μ s 100A	Test Voltage	(G Ω)	1MHz	
		(V)	(V)	(KA)	(A)	(times)	DC(V)		(pF)	
3RL075L-6	3RL075M-6	75 \pm 20%	750	5.0	5.0	200	25	1.0	2.0	3RL075-6
3RL090L-6	3RL090M-6	90 \pm 20%	750	5.0	5.0	200	50	1.0	2.0	3RL090-6
3RL150L-6	3RL150M-6	150 \pm 20%	800	5.0	5.0	200	100	1.0	2.0	3RL150-6
3RL230L-6	3RL230M-6	230 \pm 20%	800	5.0	5.0	200	100	1.0	2.0	3RL230-6
3RL250L-6	3RL250M-6	250 \pm 20%	800	5.0	5.0	200	100	1.0	2.0	3RL250-6
3RL300L-6	3RL300M-6	300 \pm 20%	900	5.0	5.0	200	100	1.0	2.0	3RL300-6
3RL350L-6	3RL350M-6	350 \pm 20%	900	5.0	5.0	200	100	1.0	2.0	3RL350-6
3RL470L-6	3RL470M-6	470 \pm 20%	950	5.0	5.0	200	250	1.0	2.0	3RL470-6
3RL600L-6	3RL600M-6	600 \pm 20%	1300	5.0	5.0	200	250	1.0	2.0	3RL600-6
3RM075L-6	3RM075M-6	75 \pm 20%	750	10	10	300	25	1.0	2.0	3RM075-6
3RM090L-6	3RM090M-6	90 \pm 20%	750	10	10	300	50	1.0	2.0	3RM090-6
3RM150L-6	3RM150M-6	150 \pm 20%	800	10	10	300	100	1.0	2.0	3RM150-6
3RM230L-6	3RM230M-6	230 \pm 20%	800	10	10	300	100	1.0	2.0	3RM230-6
3RM250L-6	3RM250M-6	250 \pm 20%	800	10	10	300	100	1.0	2.0	3RM250-6
3RM300L-6	3RM300M-6	300 \pm 20%	900	10	10	300	100	1.0	2.0	3RM300-6
3RM350L-6	3RM350M-6	350 \pm 20%	900	10	10	300	100	1.0	2.0	3RM350-6
3RM470L-6	3RM470M-6	470 \pm 20%	950	10	10	300	250	1.0	2.0	3RM470-6
3RM600L-6	3RM600M-6	600 \pm 20%	1300	10	10	300	250	1.0	2.0	3RM600-6

Electrical Ratings

Items	Test Condition/Description	Requirement
DC Spark-over Voltage	The voltage is measured with voltage ramp $dv/dt=100V/s$. Test is between each side electrode and center electrode.	To meet the specified value
Maximum Impulse Spark-over Voltage	The maximum impulse spark-over voltage is measured with voltage ramp $dv/dt=1000V/\mu s$. Test is between each side electrode and center electrode.	

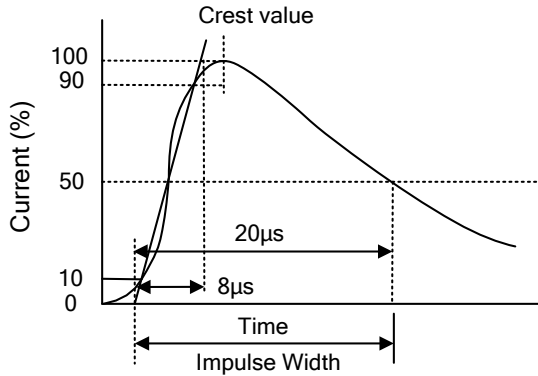
<p>Impulse Discharge Current</p>	<p>Maximum surge current that can be applied through center electrode with 8/20μs waveform, for 10 times with 3min interval time, which will be equally divided between each side electrode to center electrode, without causing the DC breakdown voltage to change more than 25% from its initial measured value.</p> 	
<p>Alternating Discharge Current</p>	<p>Rated RMS value of AC current at 50Hz, 1 sec. for 10 times with interval time 3 min. DC spark-over voltage shall not change more than $\pm 25\%$ from its initial value. Test is between each side electrode and center electrode. IR > 10⁸ ohms (-20%, +30% for 70~90V).</p>	
<p>Insulation Resistance</p>	<p>The resistance of gas tube shall be measured between each side electrodes and center electrode.</p>	
<p>Capacitance</p>	<p>The capacitance of gas tube shall be measured between each side electrodes and center electrode. Test frequency: 1MHz</p>	

Recommended Soldering Conditions

Wave Soldering

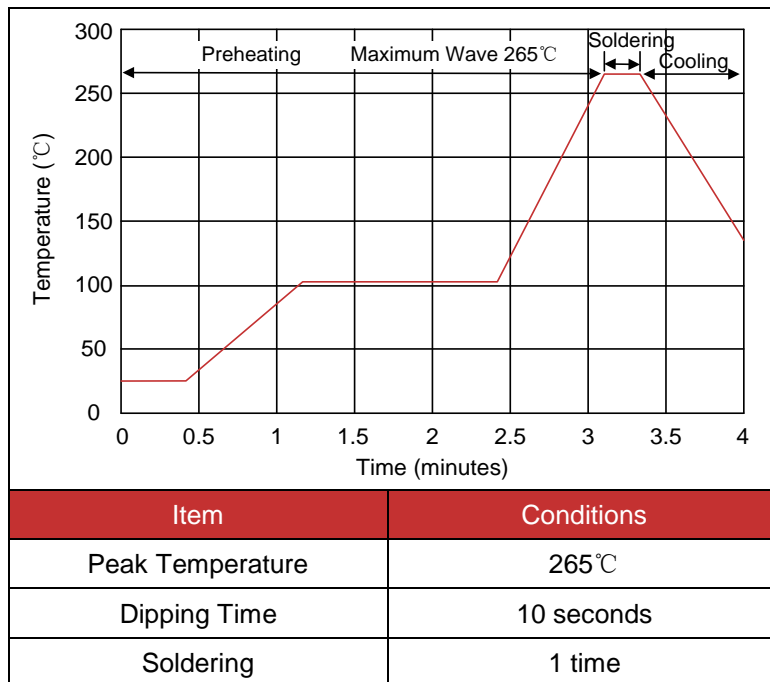

Reflow Soldering

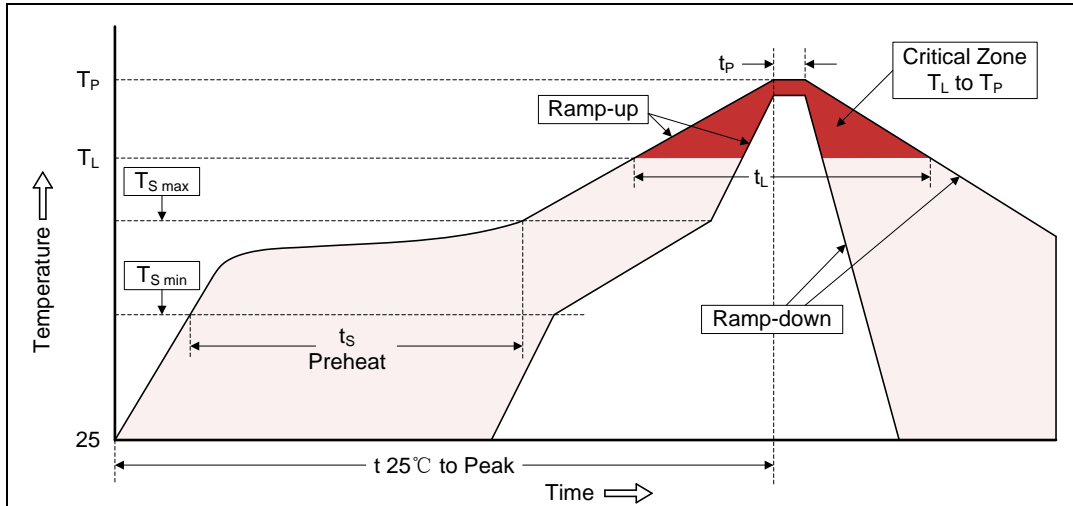

Profile Feature	Pb-Free Assembly
Average ramp-up rate (T_L to T_P)	3°C/second max.
Preheat	
-Temperature Min ($T_{S\ min}$)	150°C
-Temperature Max ($T_{S\ max}$)	200°C
-Time (min to max) (t_s)	60-180 seconds
$T_{S\ max}$ to T_L	
-Ramp-up Rate	3°C/second max.
Time maintained above:	
-Temperature (T_L)	217°C
-Time (t_L)	60-150 seconds
Peak Temperature (T_P)	260°C
Time within 5°C of actual Peak Temperature (t_p)	20-40 seconds
Ramp-down Rate	6°C/second max.
Time 25°C to Peak Temperature	8 minutes max.

Packaging

Axial Packing (Bulk)

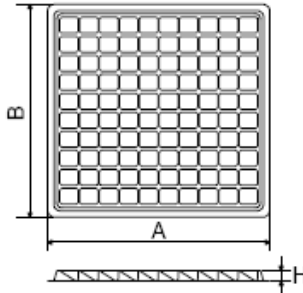
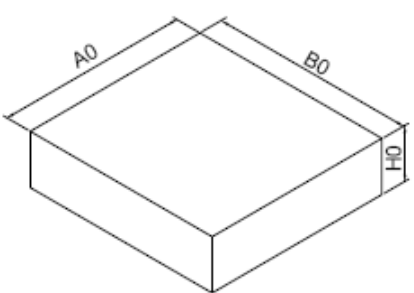
Skin packing		Dimension (mm)		
		Symbol	Spec.	Tolerance
		A	217.0	±2.0
		B	207.0	±2.0
		H	10.3	±0.5
Quantity: 100pcs				
Inner box		A0	225.0	±2.0
		B0	210.0	±2.0
		H0	60.0	±2.0
		Quantity: 500pcs		

SMD Packing (Tape & Reel)

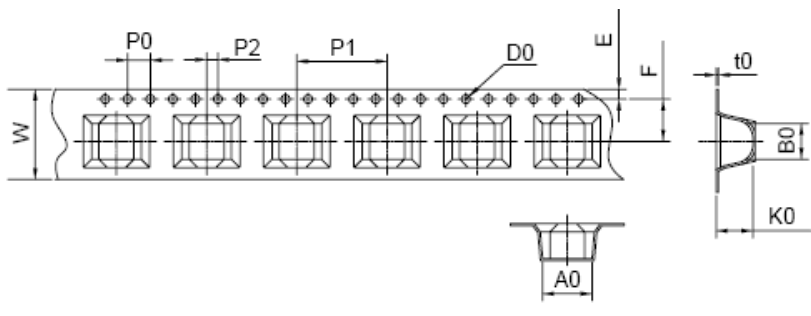
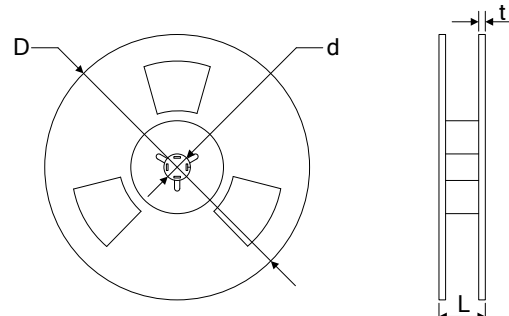
Tape		Dimension (mm)		
		Symbol	Spec.	Tolerance
		W	16.00	±0.20
		P0	4.00	±0.10
		P1	16.00	±0.10
		P2	2.00	±0.10
		D0	1.55	±0.05
		E	1.75	±0.10
		F	7.50	±0.10
		A0	8.80	±0.10
		K0	6.20	±0.10
		B0	6.35	±0.10
		t0	0.50	±0.05
		Reel		D
d	13.00			±0.50
L	20.00			±2.00
t	2.00			±0.20
Quantity: 600pcs				