

REV.NO.:1

承 认 书
SPECIFICATION FOR APPROVAL

ROHS

CUSTOMER:

品 名 Part Name	LINE FILTER	请客户承认后回签本公司 Please return one copy after approved
料 号 Model NO.	UU10.5-YH150348	
客 户 料 号 Part NO.		
规格书编号 DocumentNO.	YH-150348	

变更记录表

Alter Record

版本 REV.	修改内容 Change Description	日期 Date	修改人 Drafted By	审核 Checked By	批准 Approved By
0	新版送样	2023-4-6			

广东风华高新科技股份有限公司
FENGHUA ADVANCED TECHNOLOGY (HOLDING) CO., LTD.
地址: 广东省肇庆市风华路风华工业园 6 号楼 3 楼电感分公司.
Tel:0758-6923466
Fax:0758-2223674-8014
E-mail:dg@fenghua-yuehua.com

拟制 Designer	审核 Checker	批准 Approver

发放范围: 变压器车间, 技术 2 部, OQC, 调度组, 各一份

1. APPEARANCE AND DIMENSION. /外观图: [Unit/单位:mm]

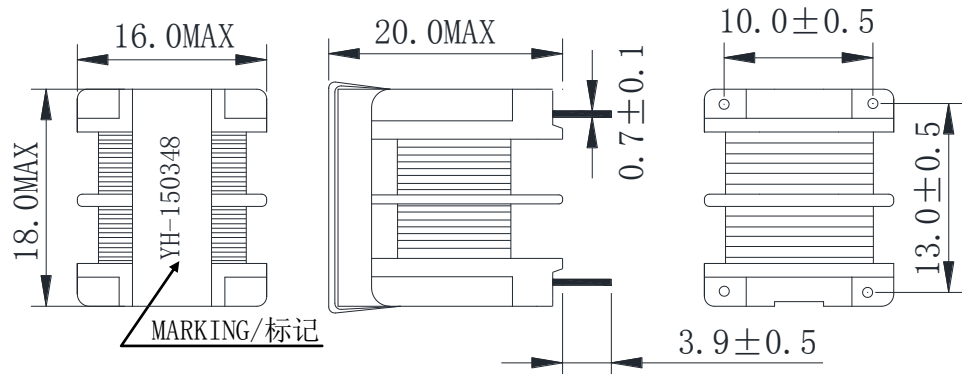

CONNECTION / 接线图

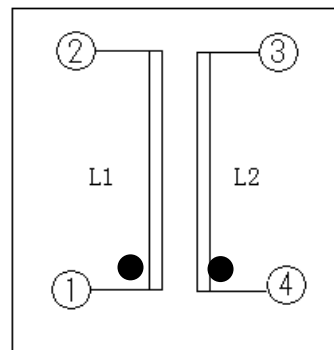

●表示卷始端。

2. WINDING SPEC. /卷线规格

WIRE /线材	2UEW*F Φ0.25mm	
PIN /端子	1--2	4--3
TURNS /圈数	120Ts (REF.)	120Ts (REF.)

VARNISH / 含浸品



广东风华高新科技股份有限公司
FENGHUA ADVANCED TECHNOLOGY (HOLDING) CO., LTD.

MODEL NO. : UU10.5-YH150348

PART NO. : UU10.5-30mH

PART NAME : LINE FILTER

DESIGNED:

CHECKED:

APPROVED:

3. ELECTRICAL CHARACTERISTICS / 电气特性

ITEM / 项目	PIN NO. / 测定端子	SPEC. / 规格	CONDITION • EQUIPMENT/ 测定器 • 条件
INDUCTANCE 电感	1--2	30mH MIN	CH-1062A or EQUIVALENT (f=1kHz, 1V)
	4--3		
L DIFFERENCE 电感偏差	L1-L2	0.5mH MAX	
DC RESISTANCE 直流电阻	1--2	2.5Ω MAX	CH-502AC or EQUIVALENT (at 25°C)
	4--3		
RATED CURRENT 额 电流	1--2 4--3	0.5A MAX	
INSULATION RESISTANCE 绝缘电阻	COIL--COIL	100MΩ MIN	CH-9053A or EQUIVALENT at DC500V
WITHSTAND VOLTAGE 耐 電 压	COIL--COIL	AC2.0KV 60S	CH-9053A or EQUIVALENT (CC=5mA)
	COIL--CORE	AC1.0KV 0S	
OPERATING TEMPERATURE RANGE 使用温度范围	—————	-20°C~+80°C	INCLUDING SELF-RESONANCE HEAT/ 包含自身的发热温度

4. MATERIAL LIST / 材料明细表

NO.	COMPONENT 名称	MATERIAL 材质	MATERIAL SPEC. 材料规格
1	BOBBIN 骨架	PHENOL 电木 T375J	SY-1012
			or EQUIVALENT
2	CORE 磁芯	FERRITE 铁氧体	SNH10 UU10.5
			or EQUIVALENT
3	WIRE 线材	POLYURETHANE COPPER 聚氨酯铜线	2UEW*F φ0.25
			or EQUIVALENT
4	CLIP 夹子	STEEL 钢	UU10.5
5	VARNISH 含浸液	EPOXY	1032
			or EQUIVALENT



广东风华高新科技股份有限公司
FENGHUA ADVANCED TECHNOLOGY (HOLDING) CO., LTD.

MODEL NO. : UU10.5-YH150348

PART NO. : UU10.5-30mH

PART NAME : LINE FILTER

DESIGNED:

CHECKED:

APPROVED: