

# Wire Wound Type Common Mode Filter

WCM3225F2SF-222T02

## 1. Features

1. High common mode impedance at high frequency cause excellent noise suppression performance.
2. WCM3225F2SF series realizes small size and low profile. 3.2x2.5x2.2 mm.
3. 100% Lead(Pb) & Halogen-Free and RoHS compliant.
4. Operating temperature-40~+125°C (Including self - temperature rise)



## 2. Dimension

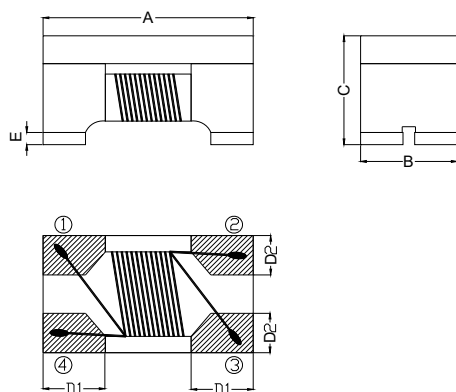

Recommended PC Board Pattern

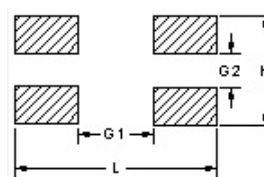

| Series   | A(mm)   | B(mm)   | C(mm)   | D1(mm)  | D2(mm)  | E(mm)    | G1(mm) | G2(mm) | H(mm) | L(mm) |
|----------|---------|---------|---------|---------|---------|----------|--------|--------|-------|-------|
| 3225F2SF | 3.2±0.2 | 2.5±0.2 | 2.2±0.2 | 0.8±0.1 | 0.9±0.1 | 0.15±0.1 | 1.6    | 0.6    | 3.5   | 4.4   |

Units: mm

## 3. Part Numbering



- A: Series  
 B: Dimension  
 C: Material Ferrite Core  
 D: Number of Lines 2=2 lines  
 E: Type S=Shielded , N=Unshielded  
 F: Lead free type  
 G: Impedance 222=2200Ω  
 H: Packaging T=Taping and Reel  
 I: Rated Current 02=200mA

## 4. Specification

| TAI-TECH Part Number | Common mode Impedance (Ω) | Test Frequency (MHz) | DC Resistance (Ω) max. | Rated Current (mA)max. | Rated Volt. (Vdc)max. | Withstand Volt. (Vdc) max. | IR (Ω) min. |
|----------------------|---------------------------|----------------------|------------------------|------------------------|-----------------------|----------------------------|-------------|
| WCM3225F2SF-222T02   | 2200±25%                  | 100                  | 0.60                   | 200                    | 50                    | 125                        | 10M         |

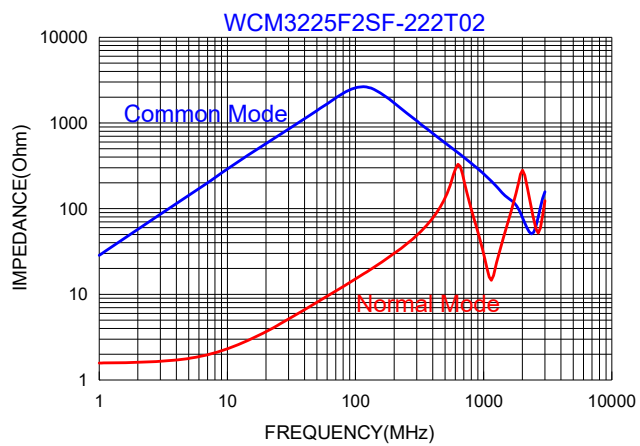

### 5. Schematic Diagram

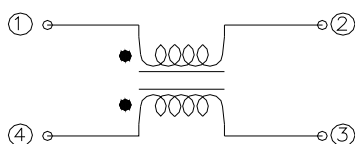

### 6. Materials

| No. | Description | Specification        |
|-----|-------------|----------------------|
| a.  | Upper plate | Ferrite              |
| b.  | Core        | Ferrite Core         |
| c.  | Termination | Ag/Ni/Sn             |
| d.  | Wire        | Enameled Copper Wire |

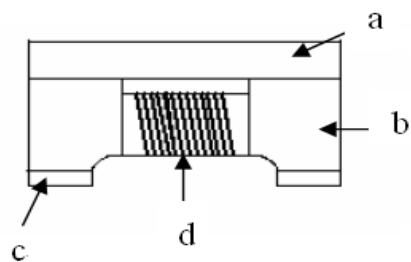

## 7. Reliability and Test Condition

| Item                               | Performance   | Test Condition  |
|------------------------------------|---|---|
| Operating temperature              | -40~+125°C (Including self - temperature rise)  |   |
| Storage temperature                | -40~+125°C (on board)   |   |
| <b>Electrical Performance Test</b> |   |   |
| Z(common mode)                     | Refer to standard electrical characteristics list.  | Keysight E4991B + Keysight 16197A   |
| DCR                                |   | Agilent-34420A<br>Agilent-4338B   |
| I.R.                               |   | Chroma 19073  |
| Temperature Rise Test              | Rated Current $\Delta T$ 40°C Max   | 1.Applied the allowed DC current.<br>2.Temperature measured by digital surface thermometer  |
| <b>Reliability Test</b>            |   |   |
| Life Test                          | Appearance : No damage.<br>Impedance : within±15% of initial value<br>RDC : within ±15% of initial value and shall not exceed the specification value | Preconditioning: Run through IR reflow for 3 times.( IPC/JEDEC J-STD-020E Classification Reflow Profiles)<br>Temperature : 125±2°C<br>Applied current : rated current<br>Duration : 1000±12hrs<br>Measured at room temperature after placing for 24 hrs.  |
| Load Humidity                      |   | Preconditioning: Run through IR reflow for 3 times.( IPC/JEDEC J-STD-020E Classification Reflow Profiles)<br>Humidity : 85±3% R.H,<br>Temperature : 85°C±2°C<br>Duration : 1000hrs Min. Bead : with 100% rated current ·<br>Inductance: with 10% rated current<br>Measured at room temperature after placing for 24 hrs.  |
| Moisture Resistance                |   | Preconditioning: Run through IR reflow for 3 times.( IPC/JEDEC J-STD-020E Classification Reflow Profiles<br>1. Baked at50°C for 25hrs, measured at room temperature after placing for 4 hrs.<br>2. Raise temperature to 65±2°C 90-100%RH in 2.5hrs, and keep 3 hours, cool down to 25°C in 2.5hrs.<br>3. Raise temperature to 65±2°C 90-100%RH in 2.5hrs, and keep 3 hours, cool down to 25°C in 2.5hrs,keep at 25°C for 2 hrs then keep at -10°C for 3 hrs<br>4. Keep at 25°C 80-100%RH for 15min and vibrate at the frequency of 10 to 55 Hz to 10 Hz, measure at room temperature after placing for 1~2 hrs. |
| Thermal shock                      |   | Preconditioning: Run through IR reflow for 3 times.( IPC/JEDEC J-STD-020E Classification Reflow Profiles<br>Condition for 1 cycle<br>Step1 : -40±2°C 30±5min<br>Step2 : 125±2°C ≤0.5min<br>Step3 : 125±2°C 30±5min<br>Number of cycles : 500<br>Measured at room temperature after placing for 24hrs  |
| Vibration                          |   | Oscillation Frequency: 10Hz~2KHz~10Hz for 20 minute<br>Equipment : Vibration checker<br>Total Amplitude:10g<br>Testing Time : 12 hours(20 minutes, 12 cycles each of 3 orientations) -  |

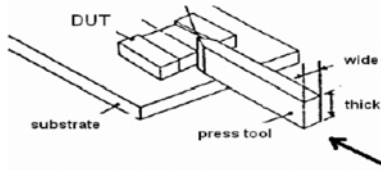
| Item                         | Performance   | Test Condition   |                       |                            |  |                       |                            |       |                |    |           |      |      |    |    |           |      |
|------------------------------|---|--|-----------------------|----------------------------|--|-----------------------|----------------------------|-------|----------------|----|-----------|------|------|----|----|-----------|------|
| Bending                      | Appearance : No damage.<br>Impedance : within±15% of initial value<br>RDC : within ±15% of initial value and shall not exceed the specification value   | Shall be mounted on a FR4 substrate of the following dimensions: >=0805 inch(2012mm):40x100x1.2mm<br><0805 inch(2012mm):40x100x0.8mm<br>Bending depth: >=0805 inch(2012mm):1.2mm<br><0805 inch(2012mm):0.8mm<br>duration of 10 sec.  |                       |                            |  |                       |                            |       |                |    |           |      |      |    |    |           |      |
| Shock                        |   | <table border="1" data-bbox="975 376 1412 510"> <thead> <tr> <th>Type</th> <th>Peak value (g's)</th> <th>Normal duration (D) (ms)</th> <th>Wave form</th> <th>Velocity change (Vi)ft/sec</th> </tr> </thead> <tbody> <tr> <td>SMD</td> <td>50</td> <td>11</td> <td>Half-sine</td> <td>11.3</td> </tr> <tr> <td>Lead</td> <td>50</td> <td>11</td> <td>Half-sine</td> <td>11.3</td> </tr> </tbody> </table> <p>3 shocks in each direction along 3 perpendicular axes. (18 shocks).</p>           | Type                  | Peak value (g's)           | Normal duration (D) (ms)                     | Wave form             | Velocity change (Vi)ft/sec | SMD   | 50             | 11 | Half-sine | 11.3 | Lead | 50 | 11 | Half-sine | 11.3 |
| Type                         | Peak value (g's)  | Normal duration (D) (ms)   | Wave form             | Velocity change (Vi)ft/sec |  |                       |                            |       |                |    |           |      |      |    |    |           |      |
| SMD                          | 50  | 11   | Half-sine             | 11.3                       |  |                       |                            |       |                |    |           |      |      |    |    |           |      |
| Lead                         | 50  | 11   | Half-sine             | 11.3                       |  |                       |                            |       |                |    |           |      |      |    |    |           |      |
| Solderability                | More than 95% of the terminal electrode should be covered with solder.  | a. Method B, 4 hrs @155°C dry heat @235°C±5°C<br>Testing Time :5 +0/-0.5 seconds<br>b. Method D category 3. (8hours ± 15 min)@ 260°C±5°C<br>Testing Time :30 +0/-0.5 seconds   |                       |                            |  |                       |                            |       |                |    |           |      |      |    |    |           |      |
| Resistance to Soldering Heat |   | Depth: completely cover the termination <table border="1" data-bbox="975 674 1406 790"> <thead> <tr> <th>Temperature(°C)</th> <th>Time(s)</th> <th>Temperature ramp/immersion and emersion rate</th> <th>Number of heat cycles</th> </tr> </thead> <tbody> <tr> <td>260 ±5 (solder temp)</td> <td>10 ±1</td> <td>25mm/s ±6 mm/s</td> <td>1</td> </tr> </tbody> </table>  | Temperature(°C)       | Time(s)                    | Temperature ramp/immersion and emersion rate | Number of heat cycles | 260 ±5 (solder temp)       | 10 ±1 | 25mm/s ±6 mm/s | 1  |           |      |      |    |    |           |      |
| Temperature(°C)              | Time(s)   | Temperature ramp/immersion and emersion rate   | Number of heat cycles |                            |  |                       |                            |       |                |    |           |      |      |    |    |           |      |
| 260 ±5 (solder temp)         | 10 ±1   | 25mm/s ±6 mm/s   | 1                     |                            |  |                       |                            |       |                |    |           |      |      |    |    |           |      |
| Terminal Strength            | Appearance : No damage.<br>Impedance : within±15% of initial value<br>RDC : within ±15% of initial value and shall not exceed the specification value e | Preconditioning: Run through IR reflow for 3 times.( IPC/JEDEC J-STD-020E Classification Reflow Profiles<br>With the component mounted on a PCB with the device to be tested, apply a force(>0805:1kg , <=0805:0.5kg)to the side of a device being tested. This force shall be applied for 60 +1 seconds. Also the force shall be applied gradually as not to apply a shock to the component being tested.  |                       |                            |  |                       |                            |       |                |    |           |      |      |    |    |           |      |

## 8. Soldering and Mounting

### 8-1. Soldering

Mildly activated rosin fluxes are preferred. TAI-TECH terminations are suitable for re-flow soldering systems. If hand soldering cannot be avoided, the preferred technique is the utilization of hot air soldering tools.

#### 8-1.1 IR Soldering Reflow:

Recommended temperature profiles for lead free re-flow soldering in Figure 1. Table 1.1&1.2 (J-STD-020E)

#### 8-1.2 Soldering Iron:

Products attachment with a soldering iron is discouraged due to the inherent process control limitations. In the event that a soldering iron must be employed the following precautions are recommended. (Figure 2.)

- Preheat circuit and products to 150°C
- Never contact the ceramic with the iron tip
- Use a 20 watt soldering iron with tip diameter of 1.0mm
- 350°C tip temperature (max)
- 1.0mm tip diameter (max)
- Limit soldering time to 4-5sec.

Fig.1 IR Soldering Reflow

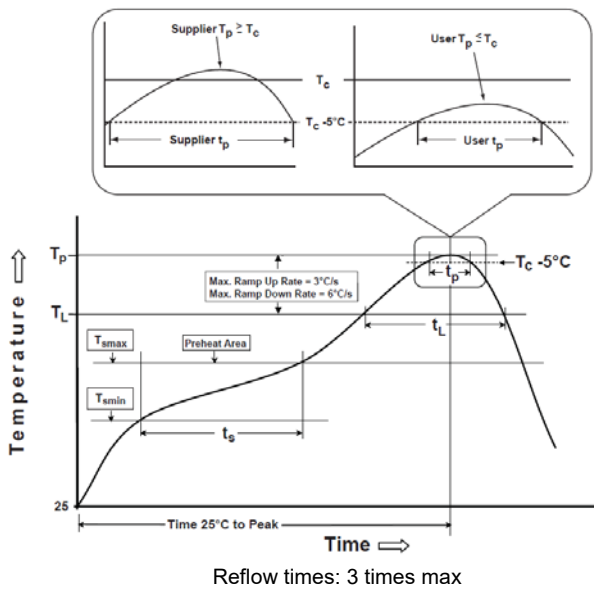
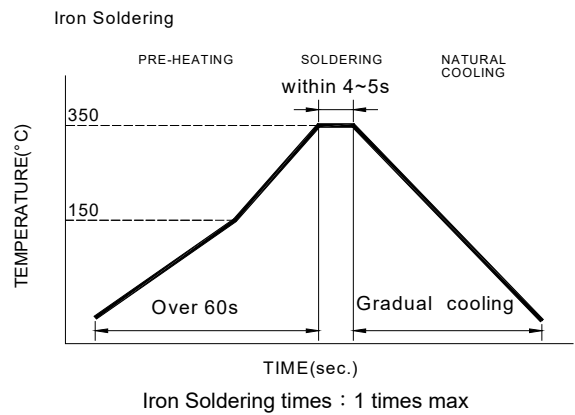

Fig.2 Iron soldering temperature profiles



**Table (1.1): Reflow Profiles**

|   |                                 |
|---|---------------------------------|
| Profile Type:   | Pb-Free Assembly                |
| Preheat<br>-Temperature Min( $T_{smin}$ )<br>-Temperature Max( $T_{smax}$ )<br>-Time( $t_s$ )from( $T_{smin}$ to $T_{smax}$ ) | 150°C<br>200°C<br>60-120seconds |
| Ramp-up rate( $T_L$ to $T_p$ )  | 3°C/second max.                 |
| Liquidus temperature( $T_L$ )<br>Time( $t_L$ )maintained above $T_L$  | 217°C<br>60-150 seconds         |
| Classification temperature( $T_c$ )   | See Table (1.2)                 |
| Time( $t_p$ ) at $T_c - 5^\circ\text{C}$ ( $T_p$ should be equal to or less than $T_c$ .)                                     | < 30 seconds                    |
| Ramp-down rate( $T_p$ to $T_L$ )  | 6°C /second max.                |
| Time 25°C to peak temperature   | 8 minutes max.                  |

$T_p$ : maximum peak package body temperature,  $T_c$ : the classification temperature.

For user (customer)  $T_p$  should be equal to or less than  $T_c$ .

**Table (1.2) Package Thickness/Volume and Classification Temperature ( $T_c$ )**

|                  | Package Thickness | Volume mm <sup>3</sup><br><350 | Volume mm <sup>3</sup><br>350-2000 | Volume mm <sup>3</sup><br>>2000 |
|------------------|-------------------|--------------------------------|------------------------------------|---------------------------------|
| PB-Free Assembly | <1.6mm            | 260°C                          | 260°C                              | 260°C                           |
|                  | 1.6-2.5mm         | 260°C                          | 250°C                              | 245°C                           |
|                  | ≥2.5mm            | 250°C                          | 245°C                              | 245°C                           |

Reflow is referred to standard IPC/JEDEC J-STD-020E ◦

## 9. Packaging Information

### 9-1. Reel Dimension

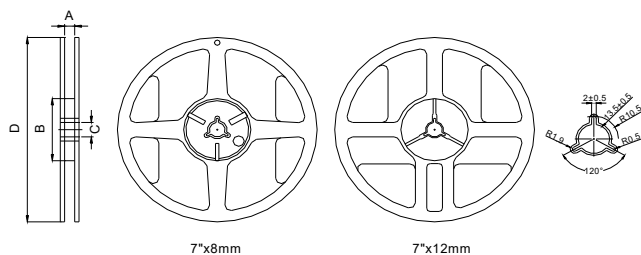

| Type   | A(mm)   | B(mm)    | C(mm)    | D(mm)     |
|--------|---------|----------|----------|-----------|
| 7"x8mm | 9.0±0.5 | 60.0±2.0 | 13.5±0.5 | 178.0±2.0 |

### 9-2. Tape Dimension / 8mm

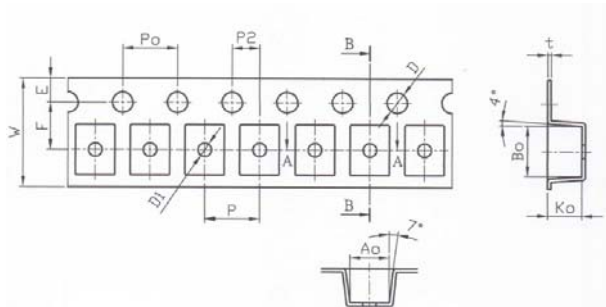

| Series     | W(mm)     | P(mm)     | E(mm)     | F(mm)     | P2(mm)    | D(mm)           | D1(mm)    | P0(mm)    | A0(mm)    | B0(mm)    | K0(mm)    | t(mm)     |
|------------|-----------|-----------|-----------|-----------|-----------|-----------------|-----------|-----------|-----------|-----------|-----------|-----------|
| WCM3225F2S | 8.00±0.10 | 4.00±0.10 | 1.75±0.10 | 3.50±0.05 | 2.00±0.05 | 1.50+0.10/-0.00 | 1.00±0.10 | 4.00±0.10 | 2.88±0.10 | 3.72±0.10 | 2.50±0.10 | 0.26±0.05 |

### 9-3. Packaging Quantity

| Chip size  | Chip/Reel | Inner Box | Middle Box | Carton |
|------------|-----------|-----------|------------|--------|
| WCM3225F2S | 2000      | 10000     | 50000      | 100000 |

### 9-4. Tearing Off Force

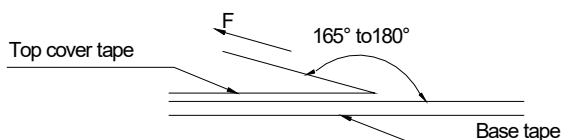

The force for tearing off cover tape is 15 to 80 grams in the arrow direction under the following conditions.

| Room Temp. (°C) | Room Humidity (%) | Room atm (hPa) | Tearing Speed mm/min |
|-----------------|-------------------|----------------|----------------------|
| 5~35            | 45~85             | 860~1060       | 300                  |

#### Application Notice

- Storage Conditions(component level)
  - To maintain the solderability of terminal electrodes:
    1. TAI-TECH products meet IPC/JEDEC J-STD-020E standard-MSL, level 1.
    2. Temperature and humidity conditions: Less than 40°C and 60% RH.
    3. Recommended products should be used within 12 months form the time of delivery.
    4. The packaging material should be kept where no chlorine or sulfur exists in the air.
- Transportation
  1. Products should be handled with care to avoid damage or contamination from perspiration and skin oils.
  2. The use of tweezers or vacuum pick up is strongly recommended for individual components.
  3. Bulk handling should ensure that abrasion and mechanical shock are minimized.