

REV.	ECN.	NO.	APPD.
A	BC-20-0026749		Davy Bu 10/08'20
B	BC-20-0034396		Davy Bu 12/08'20
BX1	20210504		Davy Bu 05/04'21
BX2	20210520		Davy Bu 05/04'21
BX3	20210608		Davy Bu 05/08'21
BX4	20210720		Davy Bu 07/20'21

- NOTES: UNLESS OTHERWISE SPECIFIED:
1. ALL DIMENSIONS ARE IN MILLIMETER.
 2. INTERPRET DRAWINGS PER ASME Y14.5M-1994
 3. MAKE SURE ALL EJECTORES IN FULLY CLOSED POSITION BEFORE REFLOW PROCESS.
 4. THE TIE-BAR'S BEVEL IS NOT TO HIT THE PLATED CONTACTS.
 5. HARDTRAY MATERIAL:HIPS, HARDTRAY COLOR: BLACK.
 6. RECOMMENDED STENCIL DIMENSIONS:

REFLOW CONDITION	THICKNESS OF STENCIL
AIR	0.18MIN
NITROGEN	0.18MIN
REWORK	0.20MIN

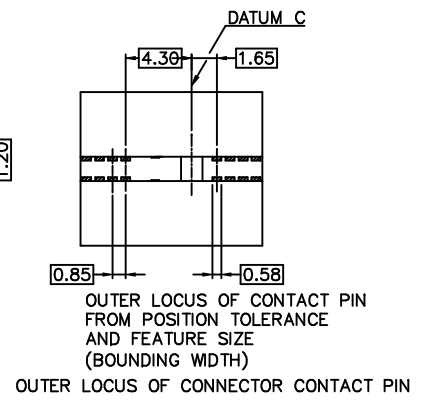
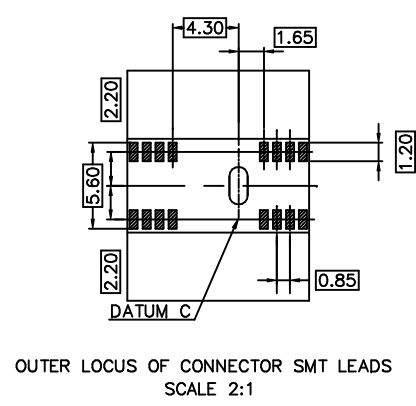
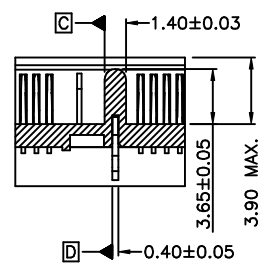
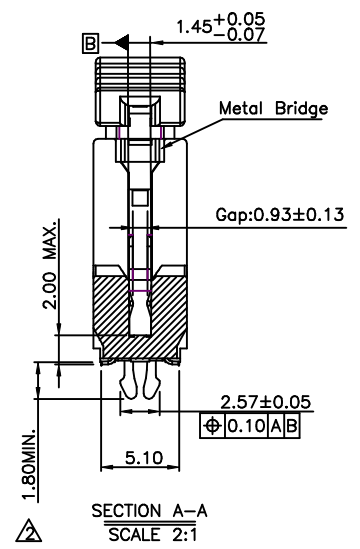
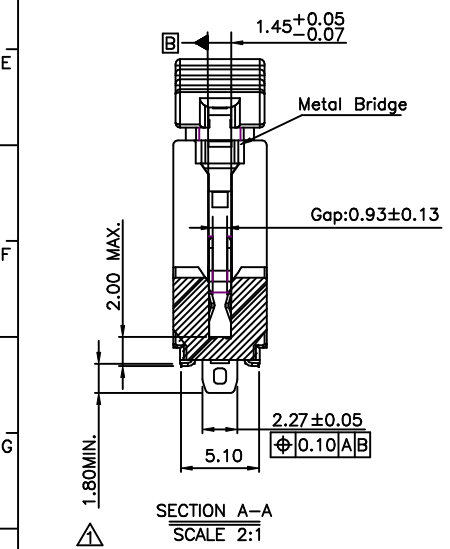
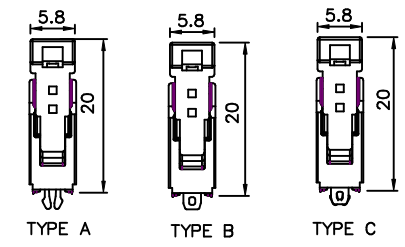
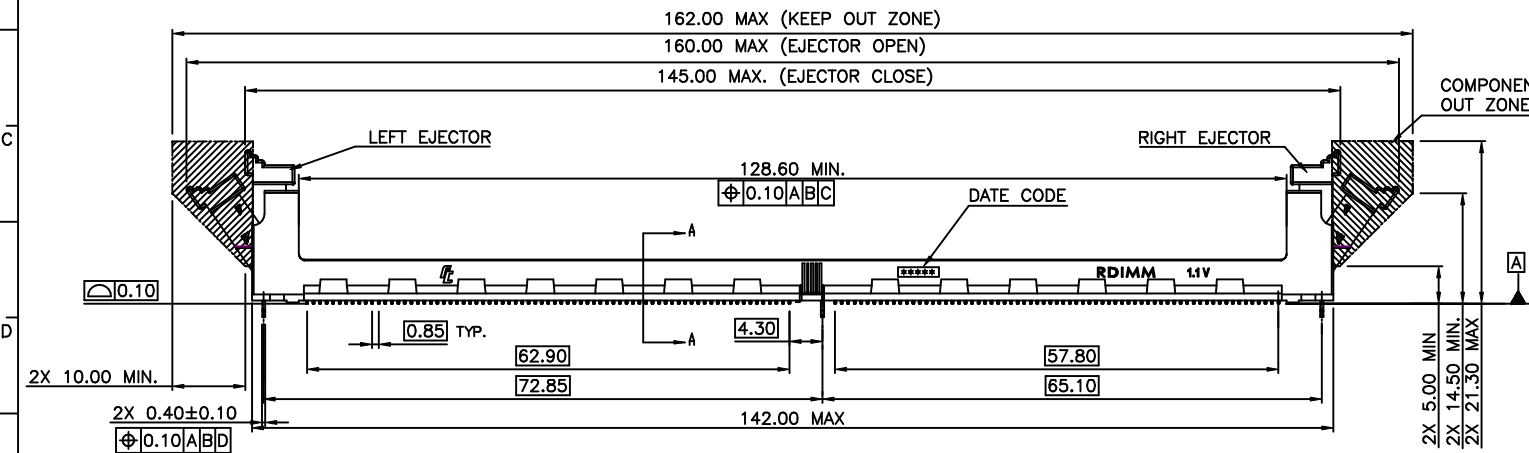
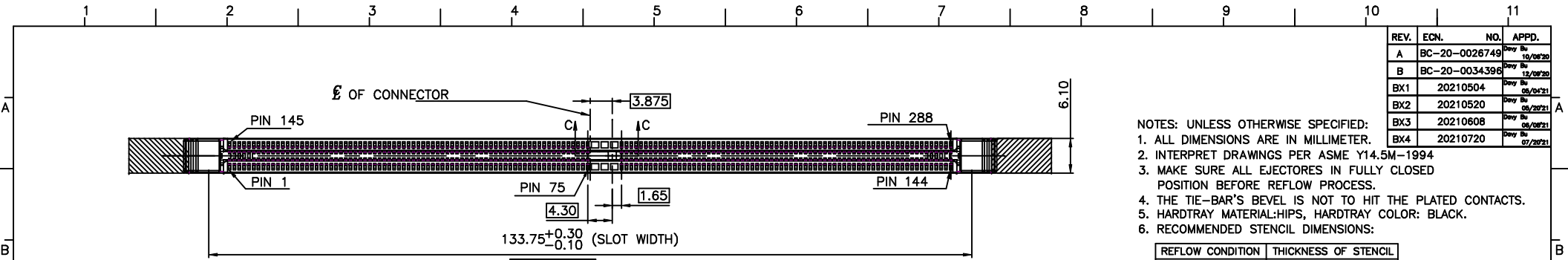

FOR ATF588(9)*-A2**0-**
FOR ATF588(9)*-A7**0-**

FOR ATF589*-A9**0-**
FOR ATF588(9)*-A7**0-**

x.± 0.38	x.±	UNITS	mm	NAME(INTENDED USE)	 FOXCONN INTERCONNECT TECHNOLOGY LIMITED.
.xx± 0.25	.x±	MATL	N/A	RDIMM DDR5,288 PIN 0.85mm PITCH,SMT	
.xxx± 0.15	.xx±	FINISH	N/A	PART NO.(INTENDED USE)	CLASS: <input type="checkbox"/> SECRET <input type="checkbox"/> CONFIDENTIAL <input type="checkbox"/> GENERAL
.xxx±	.xxx±	Q'TY	N/A	ATF58** - A***0 - **	TITLE: CUSTOMER DRAWING
				APPD: Davy Bu 07/20'21	DWG NO.: 317-0014-3248
				CHKD: Johnny Tang 07/20'21	SCALE SHEET REV.
				DR: Cohen Xie 07/20'21	N/A 1/7 BX4

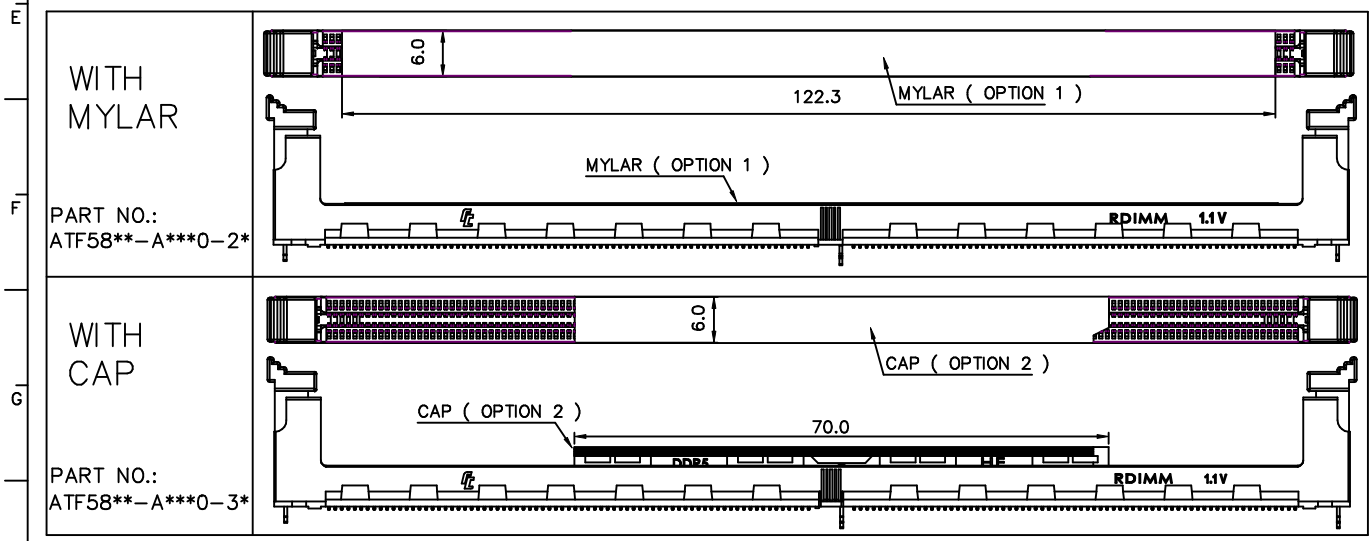
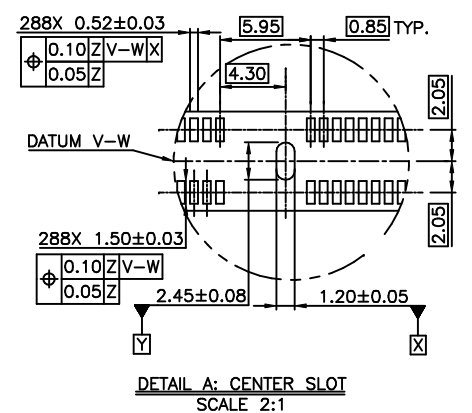
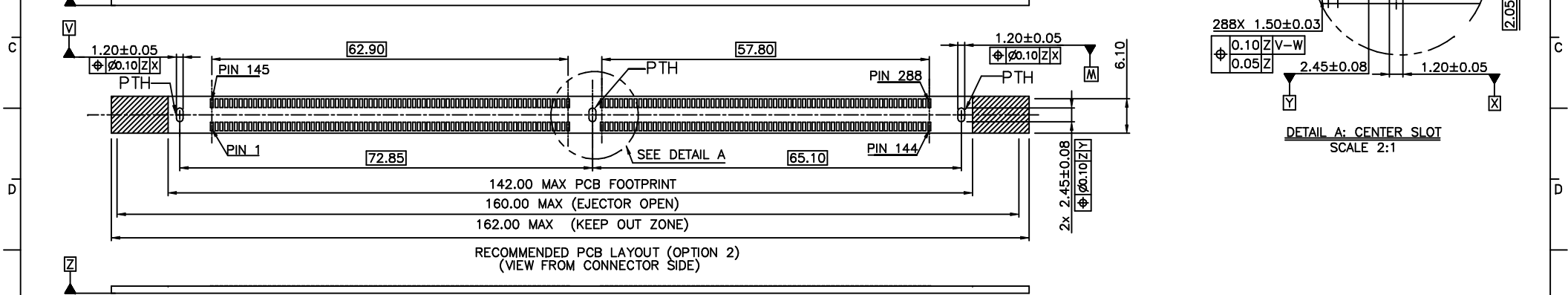
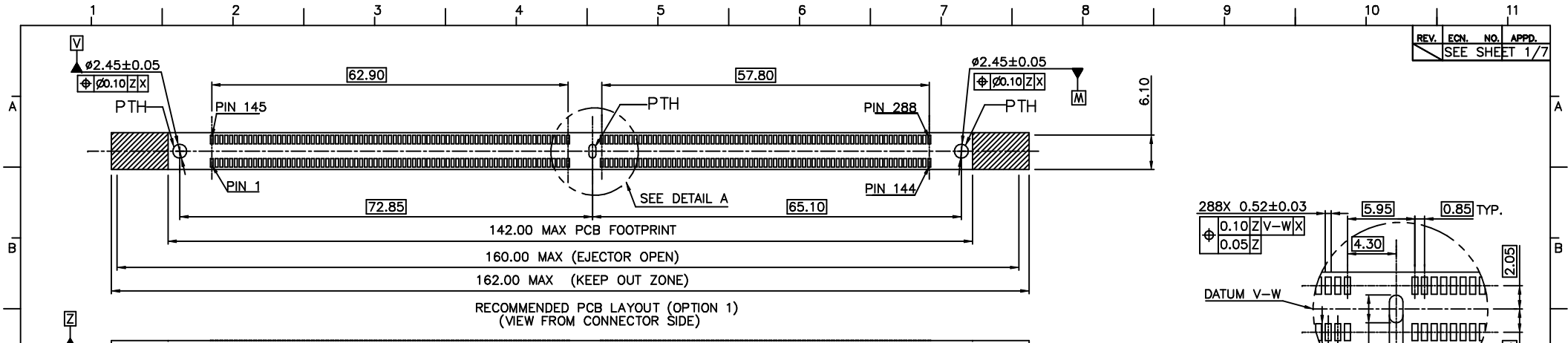

WITH MYLAR

PART NO.:
ATF58** - A***0-2*

WITH CAP

PART NO.:
ATF58** - A***0-3*

x.± 0.38	x.±	UNITS	mm	NAME (INTENDED USE)	 FOXCONN INTERCONNECT TECHNOLOGY LIMITED.
.x± 0.25	.x±	MAT'L	N/A	RDIMM DDR5, 288 PIN 0.85mm PITCH, SMT	
.xx± 0.15	.xx±	FINISH	N/A	PART NO. (INTENDED USE)	CLASS: <input type="checkbox"/> SECRET <input checked="" type="checkbox"/> CONFIDENTIAL <input type="checkbox"/> GENERAL
.xxx±	.xxx±	Q'TY	N/A	ATF58** - A***0 - **	TITLE: CUSTOMER DRAWING
				APPD: Davy Bu 07/20'21	DWG NO.: 317-0014-3248
				CHKD: Johnny Tang 07/20'21	SCALE SHEET REV.
				DR: Cohen Xie 07/20'21	N/A 2/7 BX4

PART NUMBER	POSITION	HOOK LENGTH Δ	TAB LENGTH Δ	TYPE
ATF589*-A9**0-**-	288	2.13+/-0.25	/	TYPE A
ATF588*-A2**0-**-	288	/	1.90+0.25/-0.10	TYPE B
ATF588*-A7**0-**-	288	2.13+/-0.25	1.90+0.25/-0.10	TYPE C
ATF589*-A2**0-**-	288	/	2.60+/-0.25	TYPE B
ATF589*-A7**0-**-	288	2.13+/-0.25	2.60+/-0.25	TYPE C

REV.	ECN. NO.	APPD.
SEE SHEET 1/7		

TYPE A :
3 HOOK TYPE

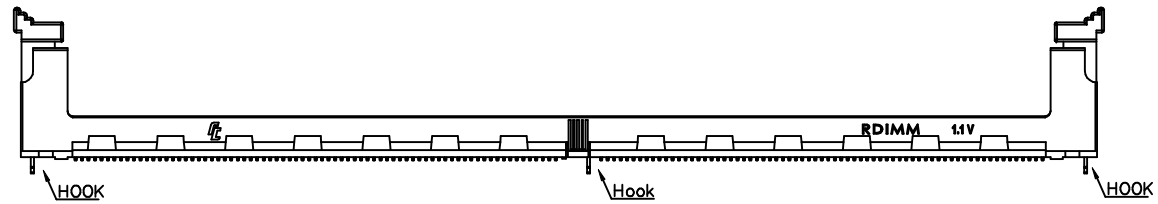

TYPE B :
3 TAB TYPE

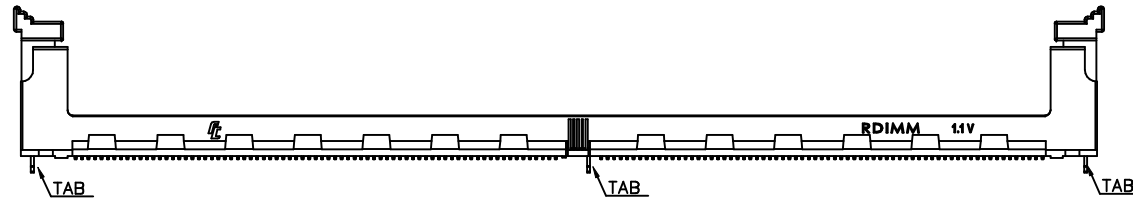

TYPE C :
2 End TAB+ 1 Center HOOK

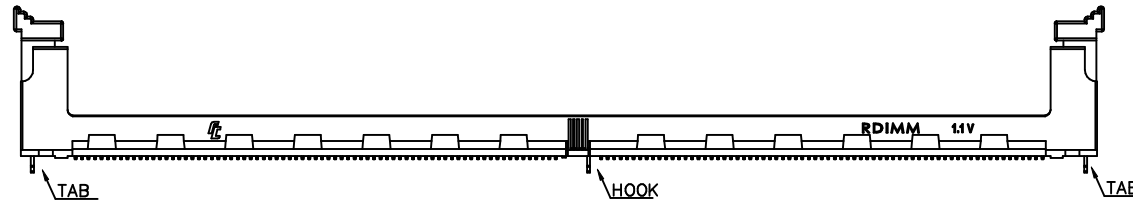

x.± 0.38	x.±	UNITS	mm	NAME(INTENDED USE)	RDIMM DDR5, 288 PIN 0.85mm PITCH, SMT	
.x± 0.25	.x±	MAT'L	N/A	PART NO.(INTENDED USE)	ATF58** - A***0 - **	
.xx± 0.15	.xx±	FINISH	N/A	APPD:	Davy Bu 07/20'21	CLASS: <input type="checkbox"/> SECRET <input checked="" type="checkbox"/> CONFIDENTIAL <input type="checkbox"/> GENERAL TITLE: CUSTOMER DRAWING
.xxx±	.xxx±	Q'TY	N/A	CHKD:	Johnny Tang 07/20'21	DWG NO.: 317-0014-3248
				DR:	Cohen Xie 07/20'21	SCALE SHEET REV. N/A 3/7 BX4

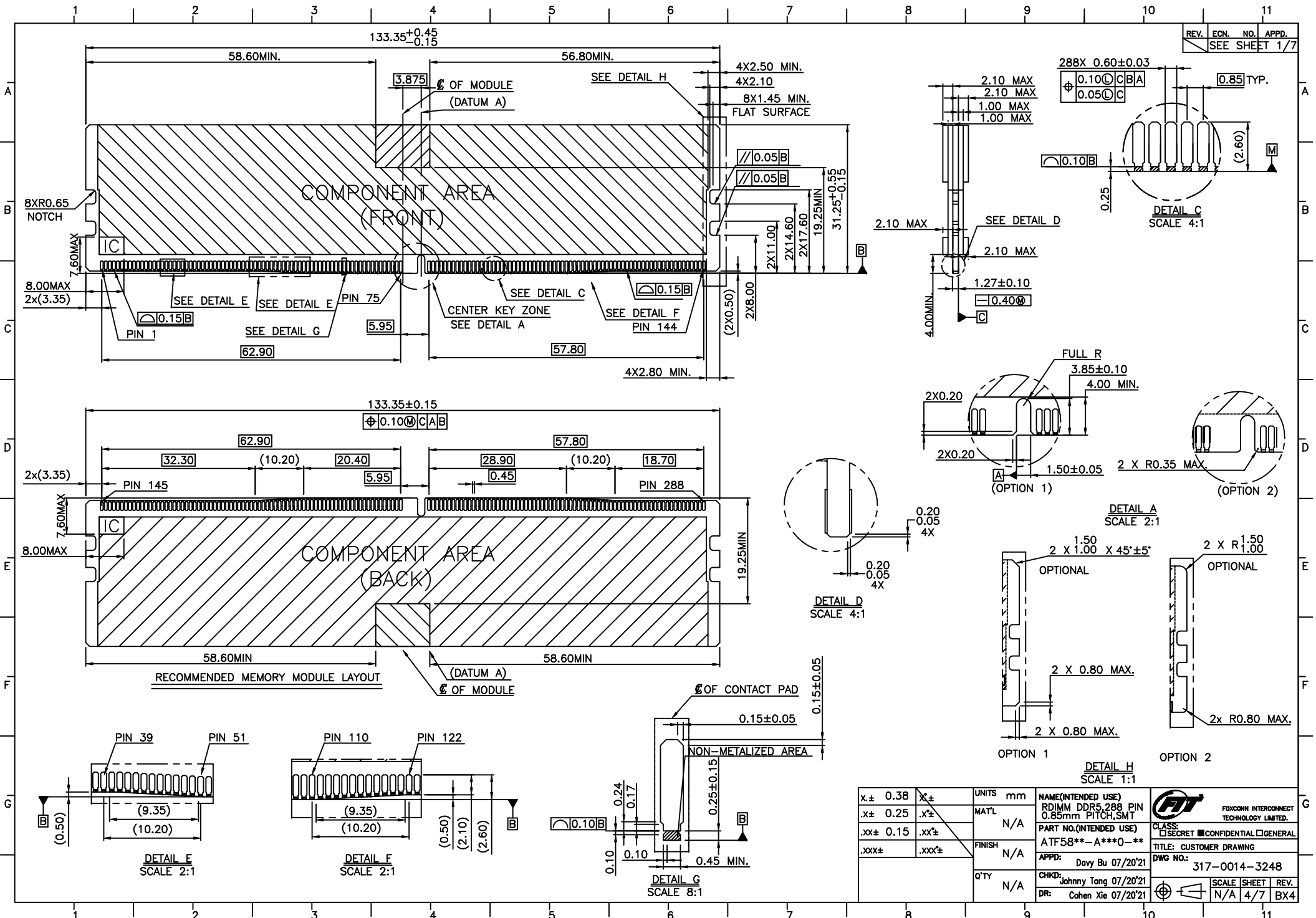

REV. ECN. NO. APPD.
SEE SHEET 1/7

FOXCONN INTERCONNECT TECHNOLOGY LIMITED.

DWG NO.: 317-0014-3248

SCALE SHEET REV.
N/A 4/7 BX4

REV.	ECN.	NO.	APPD.
SEE SHEET 1/7			

VIEW FOR PACKAGING HARD TRAY

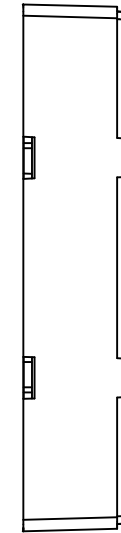
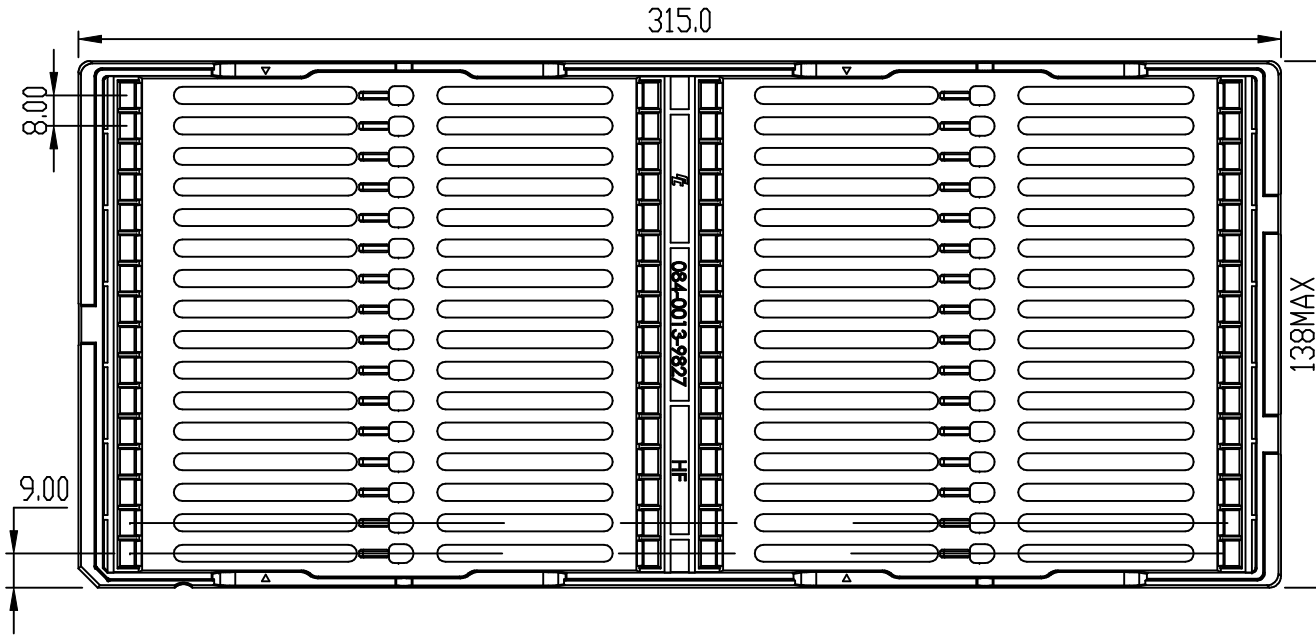

16 * 2 = 32 PCS / Tray

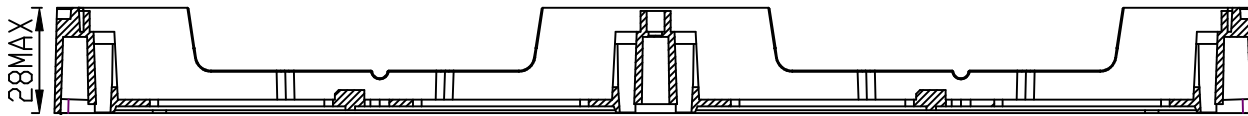

x.± 0.38	.x±	UNITS	mm	NAME(INTENDED USE)	 FOXCONN INTERCONNECT TECHNOLOGY LIMITED.
.x± 0.25	.x±	MAT'L	N/A	RDIMM DDR5_288 PIN 0.85mm PITCH,SMT	
.xx± 0.15	.xx±	FINISH	N/A	PART NO.(INTENDED USE)	CLASS: <input type="checkbox"/> SECRET <input checked="" type="checkbox"/> CONFIDENTIAL <input type="checkbox"/> GENERAL
.xxx±	.xxx±	Q'TY	N/A	ATF58**-A***0-**	TITLE: CUSTOMER DRAWING
				APPD: Davy Bu 07/20'21	DWG NO.: 317-0014-3248
				CHKD: Johnny Tang 07/20'21	SCALE SHEET REV.
				DR: Cohen Xie 07/20'21	N/A 5/7 BX4

REV.	ECN.	NO.	APPD.
SEE SHEET			1/7

VIEW FOR PACKAGING SOFT TRAY

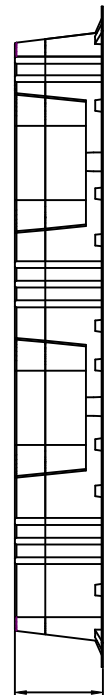
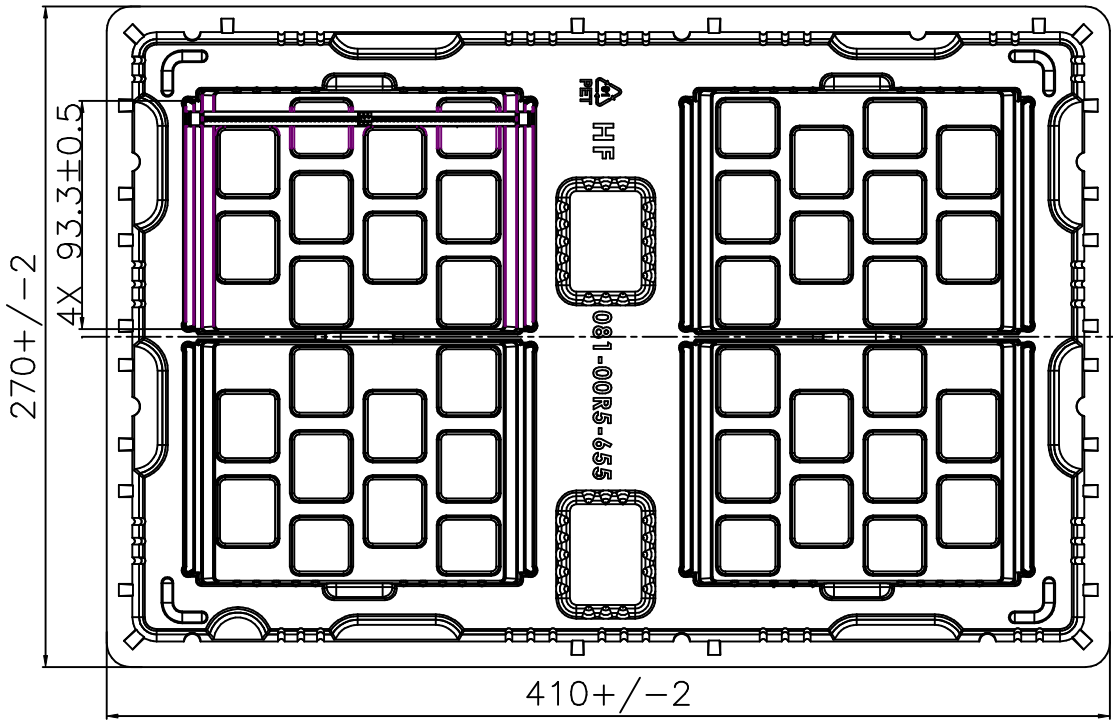

36±2.0

15 * 4 = 60 PCS / Tray

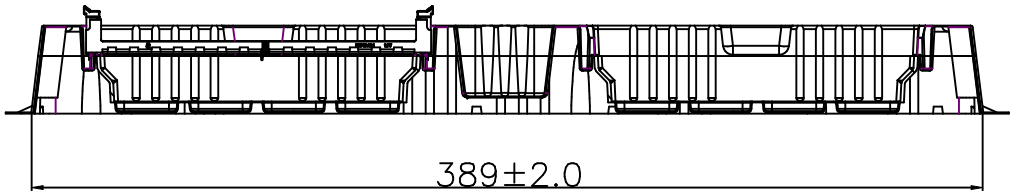

389±2.0

x.± 0.38	.x±	UNITS	mm	NAME(INTENDED USE) RDIMM DDR5,288 PIN 0.85mm PITCH,SMT PART NO.(INTENDED USE) ATF58**-A***0-**-** APPD: Davy Bu 07/20'21 CHKD: Johnny Tang 07/20'21 DR: Cohen Xie 07/20'21	FOXCONN INTERCONNECT TECHNOLOGY LIMITED. CLASS: <input type="checkbox"/> SECRET <input checked="" type="checkbox"/> CONFIDENTIAL <input type="checkbox"/> GENERAL TITLE: CUSTOMER DRAWING DWG NO.: 317-0014-3248 SCALE SHEET REV. N/A 6/7 BX4
.x± 0.25	.x±	MAT'L	N/A		
.xx± 0.15	.xx±	FINISH	N/A		
.xxx±	.xxx±	Q'TY	N/A		

SPECIFICATION:

1. PHYSICAL:

- 1-1. HOUSING:
HIGH TEMPERATURE THERMOPLASTIC, UL 94V-0, COLOR: SEE PRODUCT NOMENCLATURE
- 1-2. CONTACT:
COPPER ALLOY, NICKEL PLATING THICKNESS 90 u" MIN. ON CONTACT AREA, 50 u" MIN. ON OTHER AREA.
MATTE TIN LEAD FREE PLATING, THICKNESS 100 u" MIN. AT TAILS, GOLD PLATING AT CONTACT AREA. THICKNESS REFER TO PRODUCT NOMENCLATURE.
- 1-3. EJECTOR:
THERMOPLASTIC, UL 94V-0, COLOR: SEE PRODUCT NOMENCLATURE
- 1-4. TAB & HOOK: COPPER ALLOY.
NICKEL PLATING OVER ALL THICKNESS 50 u" MIN.
MATTE TIN PLATING OVER NICKEL THICKNESS AT 100u" MIN.
- 1-5. METAL BRIDGE: SUS304.

2. ELECTRICAL CHARACTERISTICS:

- 2-1. CONTACT CURRENT RATING: 1 AMPS MAX.
- 2-2. INSULATION RESISTANCE: 1 MEGOHMS MIN. AT 500 VDC.
- 2-3. DIELECTRIC WITHSTANDING VOLTAGE: 500 VAC AT SEA LEVEL.
- 2-4. LOW LEVEL CONTACT RESISTANCE (DRY CIRCUIT):
INITIAL: 40 MILLIOHMS MAX.
FINAL: THE CHANGE IN LLCR BETWEEN THE READING AFTER STRESS AND THE INITIAL READING SHALL NOT EXCEED 20 MILLIOHMS MAX.

3. MECHANICAL CHARACTERISTICS:

- 3-1. CONTACT RETENTION FORCE: 0.30KG. (0.66 LBS) MIN. PER PIN.
- 3-2. DURABILITY: 25 CYCLES.
- 3-3. UNMATING FORCE (PER CONTACT PAIR): 14g MIN.
- 3-4. INSERTION FORCE OF MODULE INTO CONNECTOR: 10.88KGF MAX.
- 3-5. INSERTION FORCE OF CONNECTOR INTO PCB (WITH THREE BOARD LOCKS):35NMAX.

4. ENVIRONMENTAL CHARACTERISTICS:

- 4-1. SOLDERABILITY: PASSED PER EIA-364-52, CLASS 2, CATEGORY 3.
- 4-2. VIBRATION: PASSED PER EIA-364-28.
- 4-3. HUMIDITY: PASSED PER EIA-364-31.
- 4-4. THERMAL SHOCK: PASSED PER EIA-364-32.
- 4-5. OPERATING TEMPERATURE: -40°C TO 85°C.
- 4-6. MECHANICAL SHOCK: PASSED PER EIA-364-27.

5. REFLOW SOLDER REFERENCE TEMPERATURE:

PREHEATING TEMPRETURE 150~200 Degree & 60s Min. SOLDERING TEMPRETURE 260 Degree & 10s.

PRODUCT NOMENCLATURE:

PRODUCT NO. : AT F 5 8 * * - A * * * 0 - * *

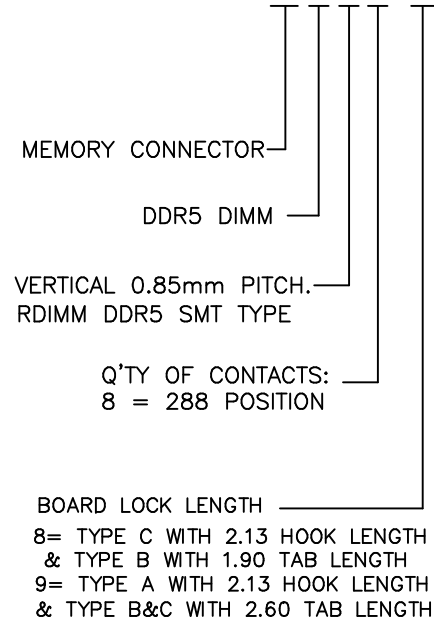

REV.	ECN.	NO.	APPD.
SEE SHEET			1/7

- F = LEAD FREE & RoHS COMPLIANCE
- H = HALOGEN FREE & RoHS COMPLIANCE
- 1 = HARD TRAY
- 2 = HARD TRAY+MYLAR
- 3 = HARD TRAY+CAP
- G = SOFT TRAY

EXTENSION CODE

- A9B20 = BLACK HOUSING & BLACK EJECTOR & TYPE A
- A9B10 = BLACK HOUSING & NATURAL EJECTOR & TYPE A
- A9L10 = BLUE HOUSING & NATURAL EJECTOR & TYPE A
- A9L20 = BLUE HOUSING & BLUE EJECTOR & TYPE A
- A9W20 = NATURAL HOUSING & NATURAL EJECTOR & TYPE A
- A9L40 = BLUE HOUSING & BLACK EJECTOR & TYPE A
- A2B20 = BLACK HOUSING & BLACK EJECTOR & TYPE B
- A2B10 = BLACK HOUSING & NATURAL EJECTOR & TYPE B
- A2B30 = BLACK HOUSING & BLUE EJECTOR & TYPE B
- A2L10 = BLUE HOUSING & NATURAL EJECTOR & TYPE B
- A2L20 = BLUE HOUSING & BLUE EJECTOR & TYPE B
- A2W20 = NATURAL HOUSING & NATURAL EJECTOR & TYPE B
- A2L40 = BLUE HOUSING & BLACK EJECTOR & TYPE B
- A7B20 = BLACK HOUSING & BLACK EJECTOR & TYPE C
- A7B10 = BLACK HOUSING & NATURAL EJECTOR & TYPE C
- A7L10 = BLUE HOUSING & NATURAL EJECTOR & TYPE C
- A7L20 = BLUE HOUSING & BLUE EJECTOR & TYPE C
- A7W20 = NATURAL HOUSING & NATURAL EJECTOR & TYPE C
- A7L40 = BLUE HOUSING & BLACK EJECTOR & TYPE C

CONTACT AREA GOLD PLATING

- 1 = 1~5 u"
- 3 = 30 u"MIN.
- 7 = 15 u"MIN.

x.± 0.38	x.±	UNITS	mm	NAME(INTENDED USE)	 FOXCONN INTERCONNECT TECHNOLOGY LIMITED.
.x± 0.25	.x±	MATL	N/A	RDIMM DDR5,288 PIN 0.85mm PITCH,SMT	
.xx± 0.15	.xx±	FINISH	N/A	PART NO.(INTENDED USE)	CLASS: <input type="checkbox"/> SECRET <input checked="" type="checkbox"/> CONFIDENTIAL <input type="checkbox"/> GENERAL
.xxx±	.xxx±	Q'TY	N/A	ATF58**-A***-**	TITLE: CUSTOMER DRAWING
				APPD: Davy Bu 07/20'21	DWG NO.: 317-0014-3248
				CHKD: Johnny Tang 07/20'21	SCALE SHEET REV.
				DR: Cohen Xie 07/20'21	N/A 7/7 BX4