

雅晶鑫電子

Shenzhen Yajingxin Electron Co.,Ltd

Customer	
Production Name	SMD OCSECSC4R SEAM 3.2*2.5
Customer P/N	N/A
P/N	TFOM33. 333M4RHKCNT2T
Revision	A
Print Date	2018-12-15

Drawn	Checked	Approved
		

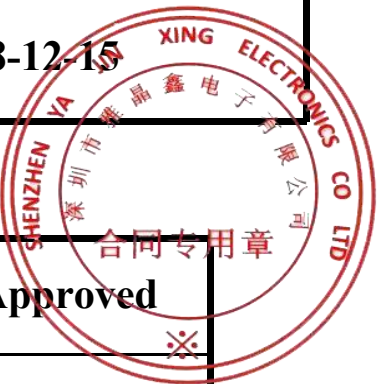

RoHS Compliant

■ Electrical Specifications

1.Model No	3225 OSC	
2.Nominal Frequency	33.333MHz	
3.Mode of Oscillation	Fundamental	
4.Operating Temperature Range	-40°C to 85 °C	
5.Storage Temperature Range	-55°C to +125°C	
6.Frequency Stability	±50ppm	
7.Power Supply Voltage	1.8V-5V±10%	
8.Input Current	5mA Max. : 33.333MHz	
9.Output Voltage	Logic High(Voh)	90%Vdd Min
	Logic Low(Vol)	10%Vdd Max
10.Output Load	15pF max CMOS Load	
11.Semmetry (at 50%VDD)	40-60%Normal	
12.Rise & Fall Time	8ns Max.	
13.E/D or N/C.	Tri-state	
14.Output Disable Time	100nsec	
15.Output Enable Time(start-up time)	10msec max	
16.Aging	±3ppm/year	
17.Unit Weight		

Dimension

S

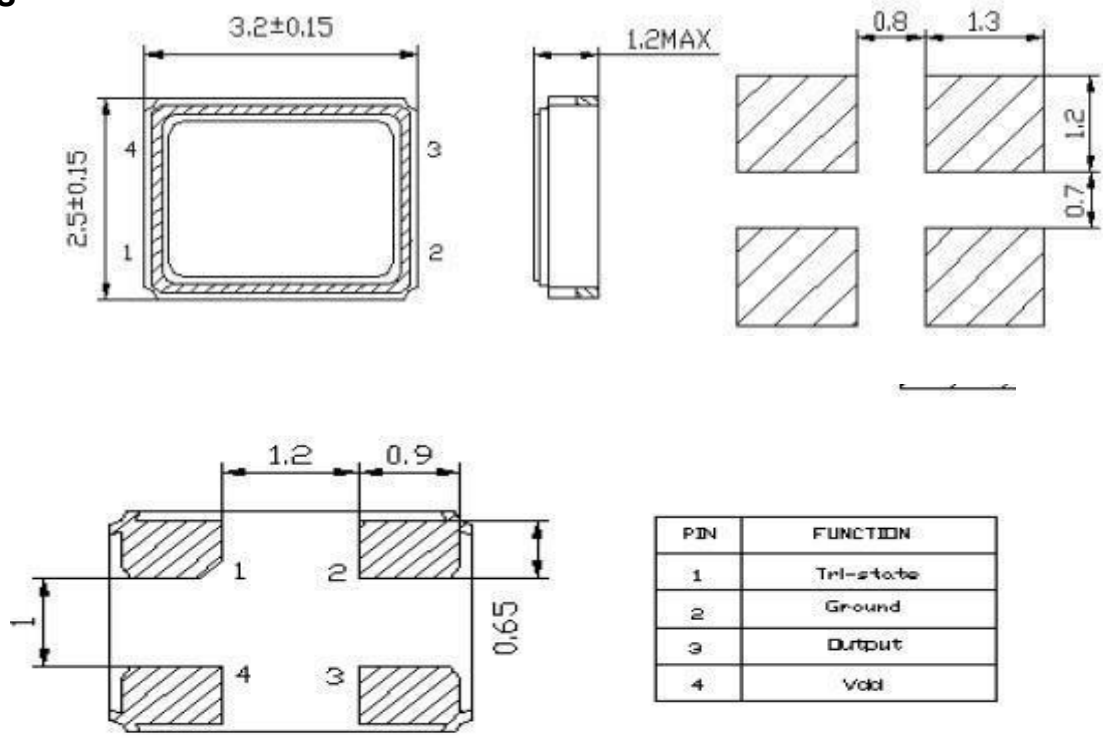

■ Marking

g

Line 1: 客户指定印字 →

Line 2: ● → Pin#1 indication



■ Measurement Circuit

Output Wave Form

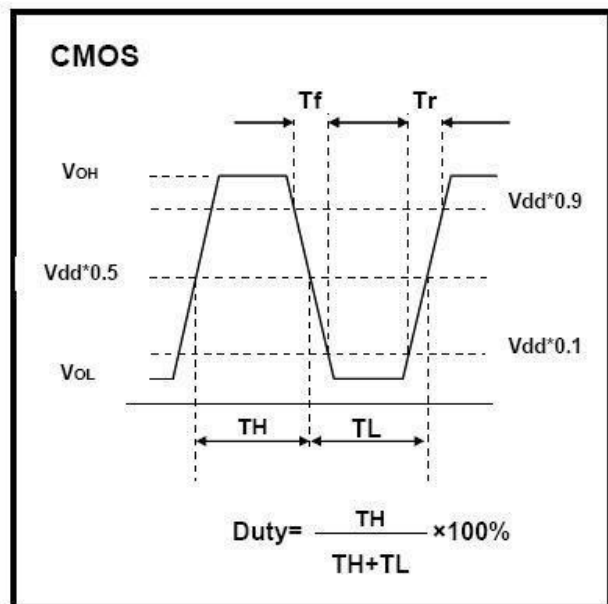
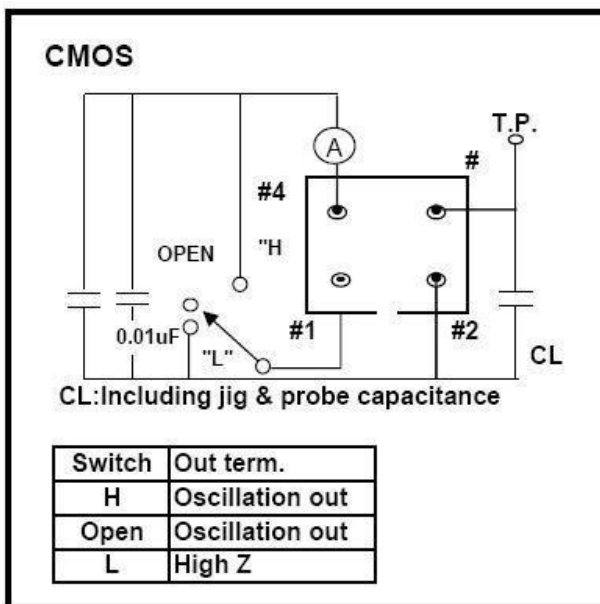

■ Input Output Condition

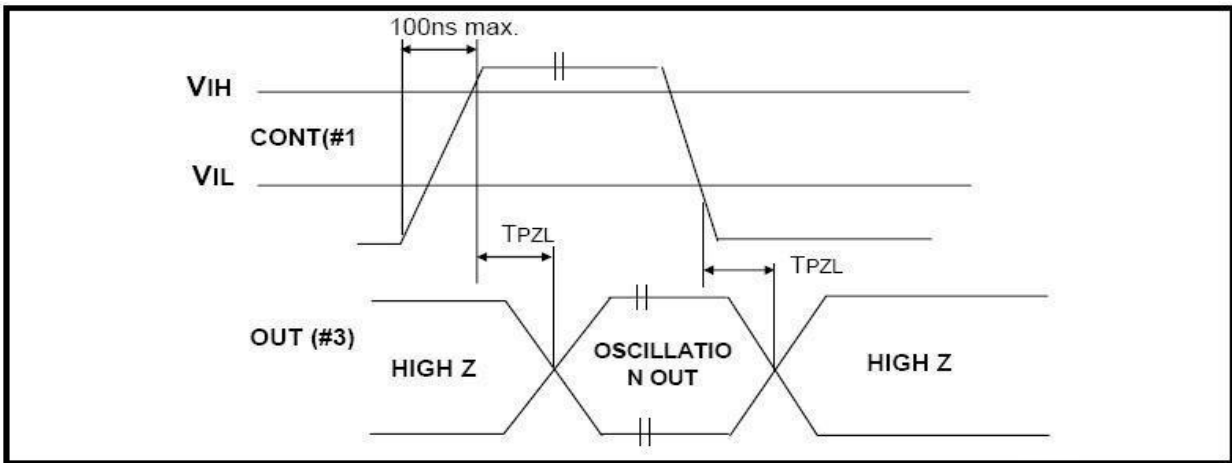

■ Reflow Profile

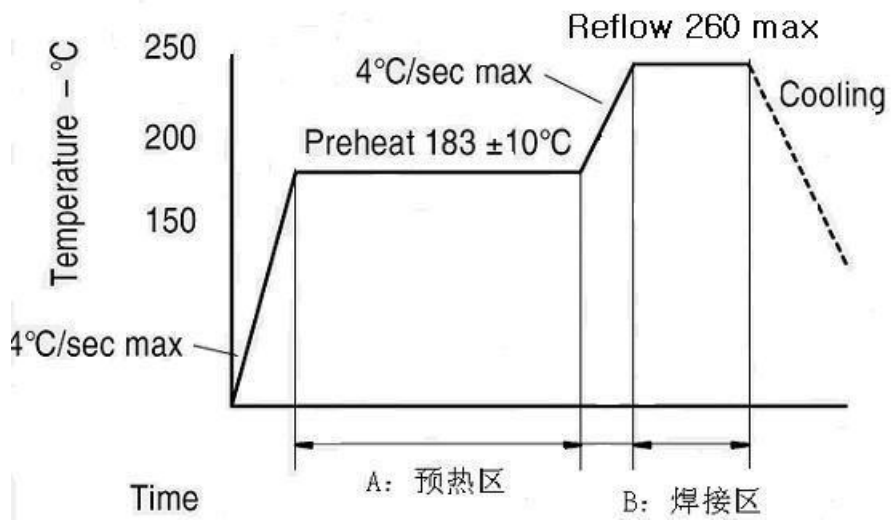

■ Reliability Specifications

No	TestItem	Test Methods
1	DROP TEST	Device are dropped from a height of 75 cm onto 3 mm thickness stainless plate executing 3 times of random drops.
2	MECHANICAL SHOCK	Device are shocked to half sine wave (1000 G) three mutually perpendicular axes each 3 times.
3	High Temp and Humidity Test	85°C/RH 85%, 500Hrs
4	High temp storage test	125°C+/-2°C 500Hrs
5	Low temp storage test	-40°C 500Hrs
6	Thermal shock test	-40°C~+85°C DWEL 60' 100cycles
7	Aging test	85°C 500Hrs
8	Resistance to solder heat	260°C 10S
9	VIBRATION	Frequency range 10-2000 Hz Amplitude Sweep 1.5 mm Sweep Time 20 minute Test Time 2 hours
10	SOLDERABILITY	MIL - STD - 20E Method 208C Temperature 245°C±5°C Material H63A (Silver 2-3 %) Immersion depth 0.5 mm minimum Immersion time 3 ± 0.5 seconds Flux Rosin resin methyl

■Packin

a

■编带 (TAPE)

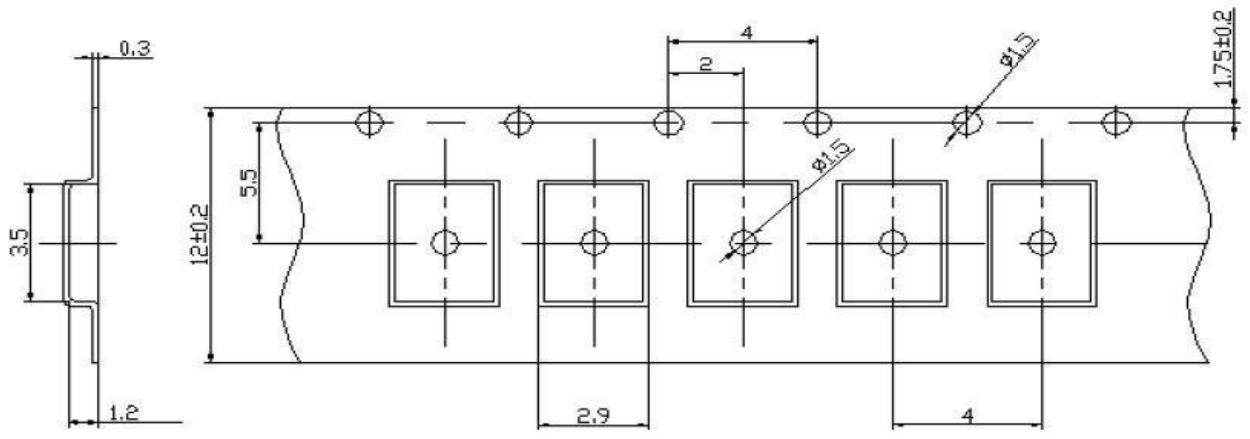

■轮 (REEL)

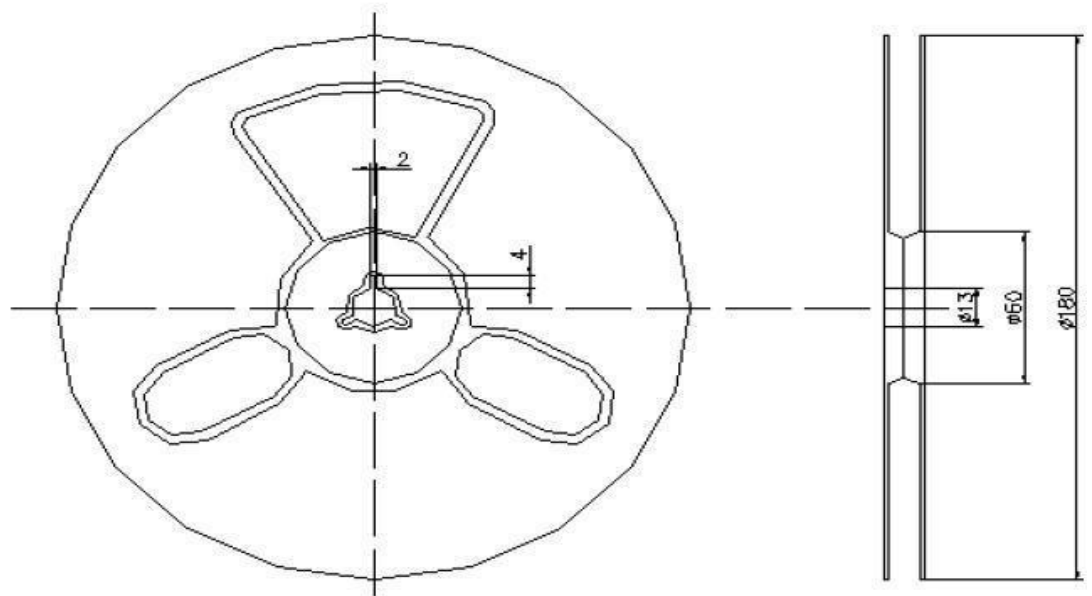

雅晶鑫電子

■ 包裝 (PACKAGE)

1. 自封袋 (Bag)

3000只=1 輪

3000pcs=1 Reel

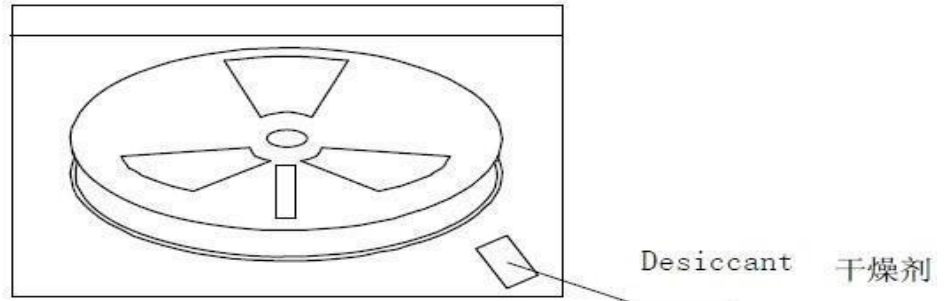

2. 內包裝 (Inside package)

1 輪=1 盒

1 Reel=1 box

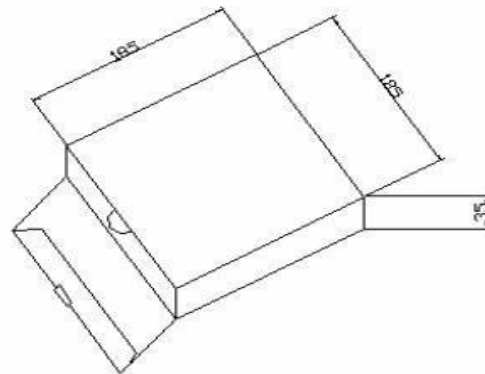

3. 外包裝 (outside Package)

10 盒=1 箱

10 box=1 carton

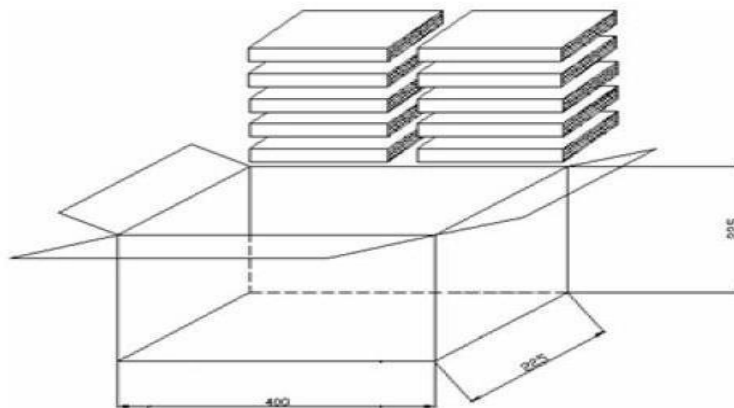

*****8*****