

## Features

- \* Low operating :5V
- \* Ultra low capacitance: 1.0 pF typical
- \* Ultra low leakage: nA level
- \* Low clamping voltage
- \* Protects one power line or data line
- \* Complies with following standards:
  - IEC 61000-4-2 (ESD) immunity test  
Air discharge:  $\pm 30\text{kV}$   
Contact discharge:  $\pm 30\text{kV}$
  - IEC61000-4-4 (EFT) 40A (5/50ns)
- \* RoHS Compliant

## Mechanical Characteristics

- \* Package: SOD-323
- \* Ultra low leakage: nA level
- \* Case Material: "Green" Molding Compound.
- \* UL Flammability Classification Rating 94V-0
- \* Moisture Sensitivity: Level 3 per J-STD-020
- \* Shipping Qty :3000pcs/7Inch Tape & Reel

## Applications

- \* Cellular Handsets and Accessories
- \* Personal Digital Assistants
- \* Notebooks and Handhelds
- \* Portable Instrumentation
- \* Peripherals

## Dimensions and Pin Configuration

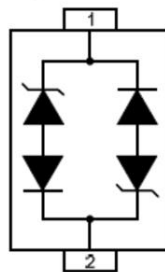

Marking: AC

**Absolute Maximum Ratings** (Tamb=25°C unless otherwise specified)

| Parameter                       | Symbol | Value       | Unit |
|---------------------------------|--------|-------------|------|
| ESD per IEC 61000-4-2 (Air)     | VESD   | ±30         | kV   |
| ESD per IEC 61000-4-2 (Contact) |        | ±30         |      |
| Operating Temperature Range     | TJ     | -55 to +125 | °C   |
| Storage Temperature Range       | Tstg   | -55 to +150 | °C   |

**Electrical Characteristics** (TA=25°C unless otherwise specified)

| Symbol           | Parameter                                  |
|------------------|--|
| V <sub>RWM</sub> | Nominal Reverse Working Voltage            |
| I <sub>R</sub>   | Reverse Leakage Current @ V <sub>RWM</sub> |
| V <sub>BR</sub>  | Reverse Breakdown Voltage @ I <sub>T</sub> |
| I <sub>T</sub>   | Test Current for Reverse Breakdown         |
| V <sub>C</sub>   | Clamping Voltage @ I <sub>PP</sub>         |
| I <sub>PP</sub>  | Maximum Peak Pulse Current                 |
| C <sub>ESD</sub> | Parasitic Capacitance                      |
| V <sub>R</sub>   | Reverse Voltage                            |
| f                | Small Signal Frequency                     |

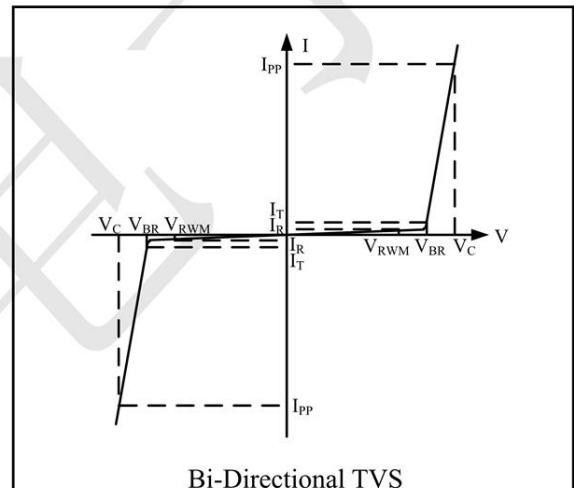

| Parameter               | Symbol           | Test Condition                         | Min | Typ | Max | Unit |
|-------------------------|------------------|--|-----|-----|-----|------|
| Reverse Working Voltage | V <sub>RWM</sub> |  |     |     | 5   | V    |
| Breakdown Voltage       | V <sub>BR</sub>  | I <sub>T</sub> = 1mA                   | 6   |     | 8   | V    |
| Reverse Leakage Current | I <sub>R</sub>   | V <sub>RWM</sub> = 5V                  |     |     | 0.2 | μA   |
| Clamping Voltage        | V <sub>C</sub>   | I <sub>PP</sub> = 1A (8 x 20μs pulse)  |     |     | 9   | V    |
| Clamping Voltage        | V <sub>C</sub>   | I <sub>PP</sub> = 10A (8 x 20us pulse) |     |     | 20  | V    |
| Junction Capacitance    | C <sub>J</sub>   | V <sub>R</sub> = 0V, f = 1MHz          |     | 1   |     | pF   |

**Electrical Characteristics ( $T_A=25^\circ\text{C}$  unless otherwise specified)**

**Fig1. 8/20 $\mu\text{s}$  Pulse Waveform**

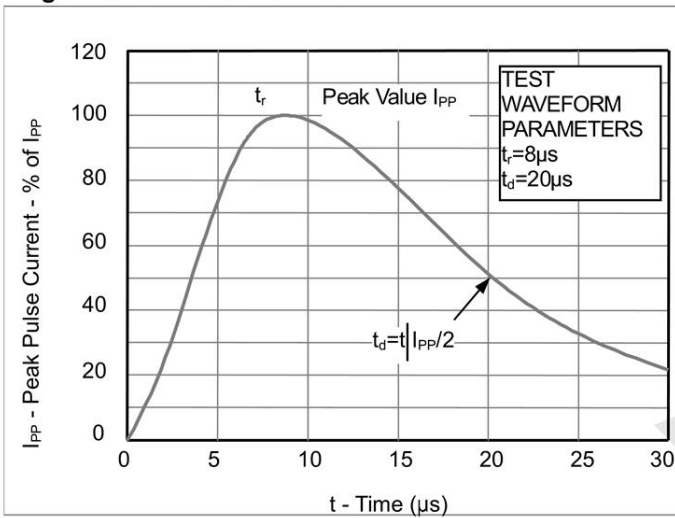

**Fig2. ESD Pulse Waveform (according to IEC 61000-4-2)**

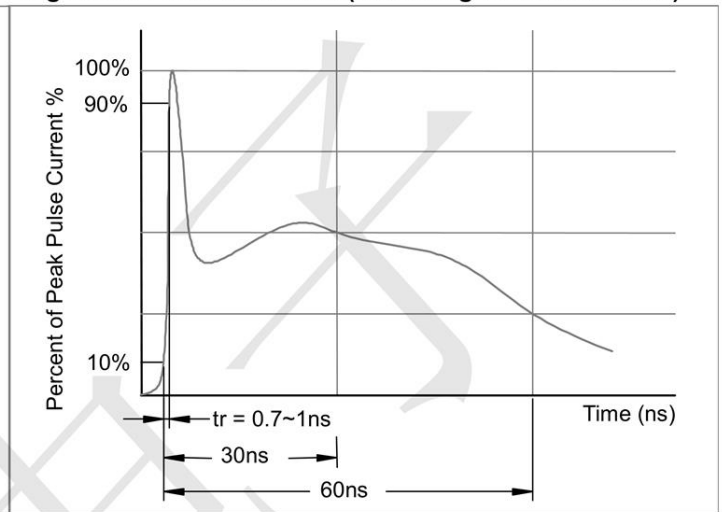

**Fig3. Power Derating Curve**

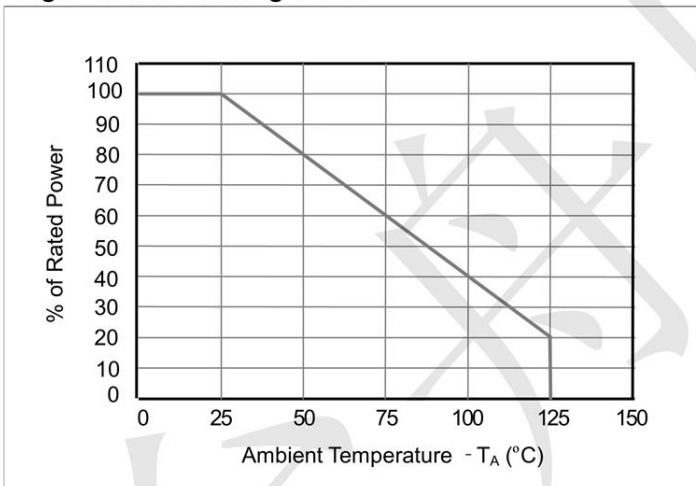

**Outline Drawing - SOD-323**

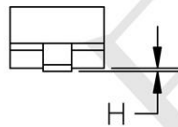
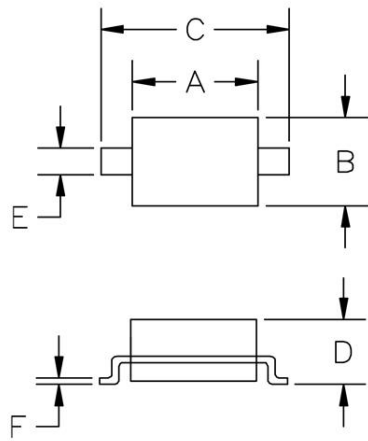

| SYM | DIMENSIONS  |      |        |       |
|-----|-------------|------|--------|-------|
|     | MILLIMETERS |      | INCHES |       |
|     | MIN         | MAX  | MIN    | MAX   |
| A   | 1.50        | 1.80 | 0.060  | 0.071 |
| B   | 1.20        | 1.40 | 0.045  | 0.054 |
| C   | 2.30        | 2.70 | 0.090  | 0.107 |
| D   | -           | 1.10 | -      | 0.043 |
| E   | 0.30        | 0.40 | 0.012  | 0.016 |
| F   | 0.10        | 0.25 | 0.004  | 0.010 |
| H   | -           | 0.10 | -      | 0.004 |

**Land Pattern - SOD-323**

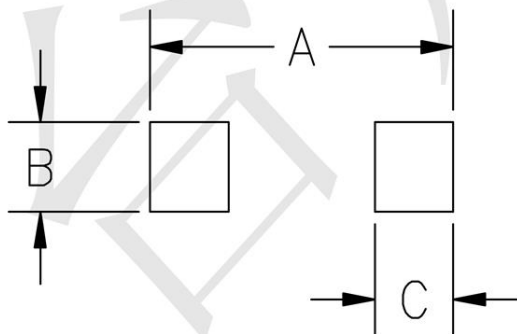

| SYM | DIMENSIONS  |        |
|-----|-------------|--------|
|     | MILLIMETERS | INCHES |
| A   | 3.15        | 0.120  |
| B   | 0.80        | 0.031  |
| C   | 0.80        | 0.031  |