

雅晶鑫電子

Shenzhen Yajingxin Electron Co.,Ltd

Customer	
Production Name	SMD OCSECSC4R SEAM 7.0*5.0
Customer P/N	N/A
P/N	TFOM50M40ZKCNT2T
Revision	A
Print Date	2018-12-15

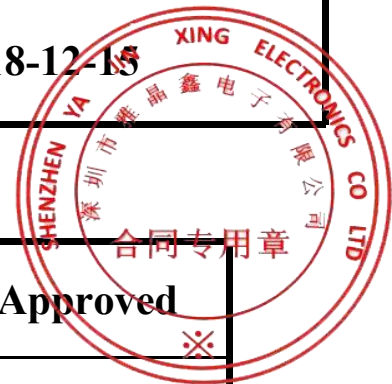

Drawn	Checked	Approved

RoHS Compliant

■ Electrical Specifications

1. Model No	7050 OSC	
2. Nominal Frequency	50.000MHz	
3. Mode of Oscillation	3rd	
4. Operating Temperature Range	-40°C to 85°C	
5. Storage Temperature Range	-55°C to +125°C	
6. Frequency Stability	±50ppm	
7. Power Supply Voltage	3.3V±10%	
8. Input Current	10mA Max. : 1.500- 32.000MHz 15mA Max. : 32.001- 50.000MHz 25mA Max. : 50.000- 70.000MHz 60mA Max. : 70.001- 125.00MHz	
9. Output Voltage	Logic High(Voh)	90%Vdd Min
	Logic Low(Vol)	10%Vdd Max
10. Output Load	15pF max CMOS Load	
11. Symmetry (at 50%VDD)	40-60%Normal	
12. Rise & Fall Time	8ns Max.	
13. E/D or N/C.	Tri-state	
14. Output Disable Time	100nsec	
15. Output Enable Time(start-up time)	10msec max	
16. Aging	±3ppm/year	
17. Unit Weight		

Dimension

s

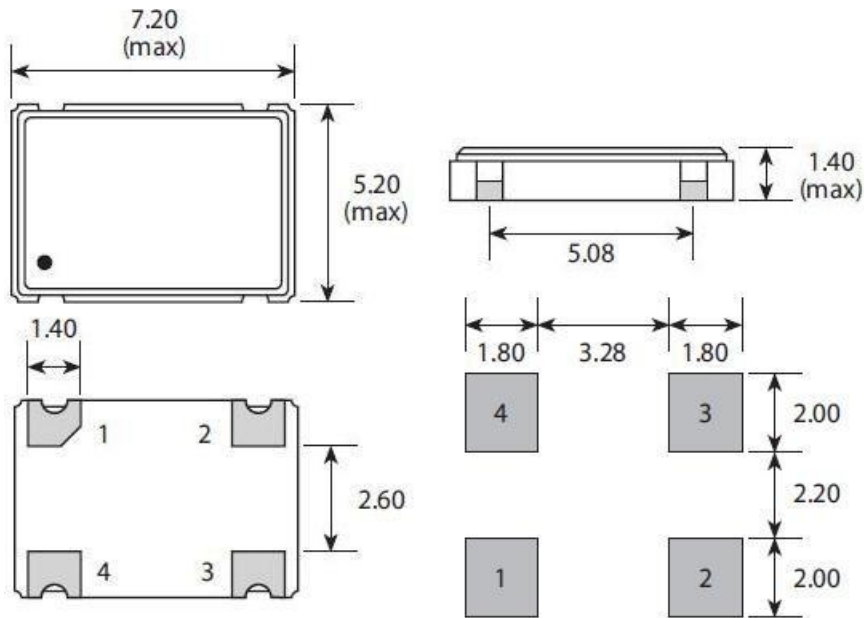

Pad	1	2	3	4
Connection	N.C.(INH)	GND	OUTPUT	VDD

Marking

g



Line 1: 客户指定印字 →

Line 2: ● → Pin#1 indication

■ Measurement Circuit

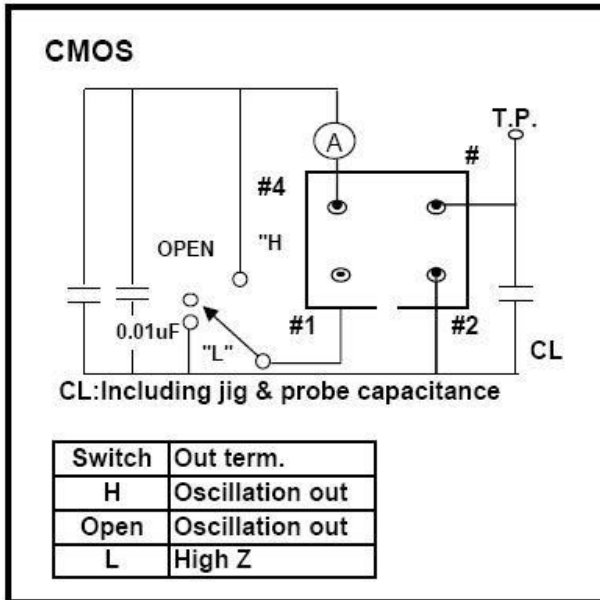

Output Wave Form

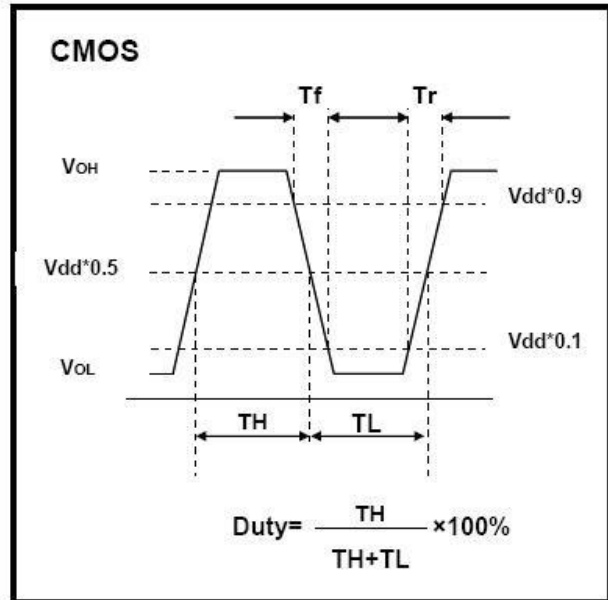

■ Input Output Condition

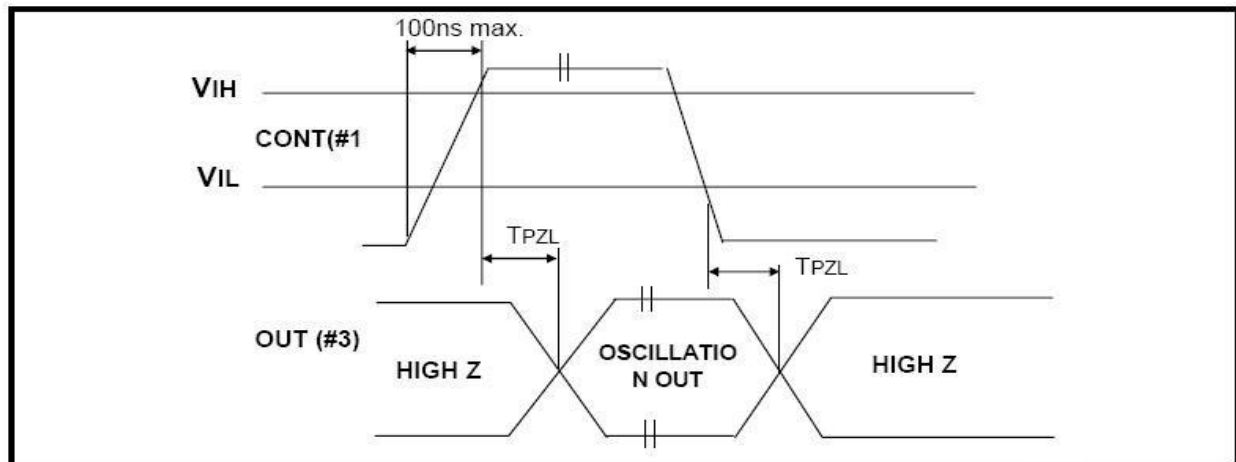

■ Reflow Profile

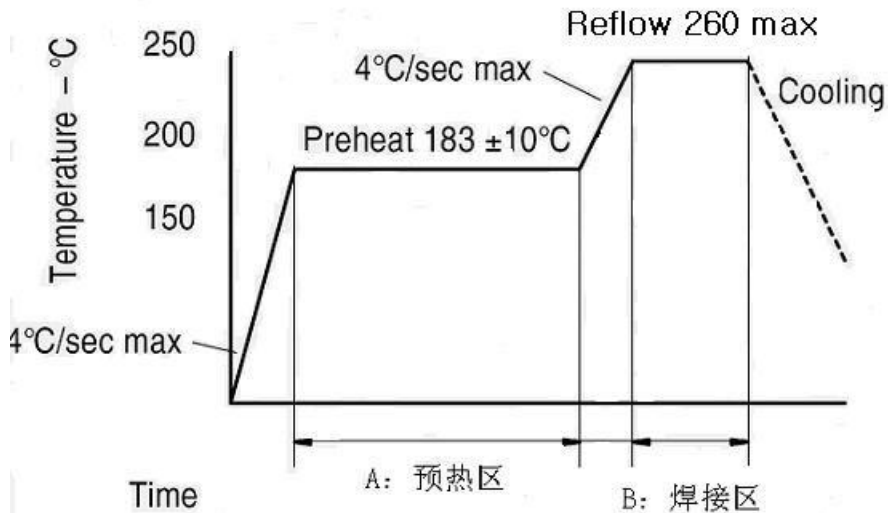

■ Reliability Specifications

No	Test Item	Test Methods
1	DROP TEST	Device are dropped from a height of 75 cm onto 3 mm thickness stainless plate executing 3 times of random drops.
2	MECHANICAL SHOCK	Device are shocked to half sine wave (1000 G) three mutually perpendicular axes each 3 times.
3	High Temp and Humidity Test	85°C/RH 85%, 500Hrs
4	High temp storage test	125°C+/-2°C 500Hrs
5	Low temp storage test	-40°C 500Hrs
6	Thermal shock test	-40°C~+85°C DWEL 60' 100cycles
7	Aging test	85°C 1000Hrs

8	Resistance to solder heat	260°C 10S
9	VIBRATION	Frequency range 10-2000 Hz Amplitude Sweep 1.5 mm Sweep Time 20 minute Test Time 2 hours
10	SOLDERABILITY	MIL - STD - 20E Method 208C Temperature 245°C±5°C Material H63A (Silver 2-3 %) Immersion depth 0.5 mm minimum Immersion time 3 ± 0.5 seconds Flux Rosin resin methyl

■ Packin

g

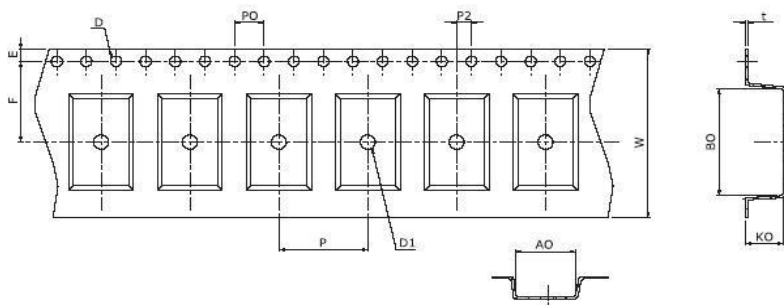

A0:5.40±0.1	B0:7.40±0.3	W:16.2±0.3	E1:1.75±0.1
P0: 4.0±0.1	P : 8.0±0.1	P2: 2.0±0.1	D: phi 1.50±0.1
F: 7.50±0.1	K0:1.90±0.1		

■ Reel Dimension

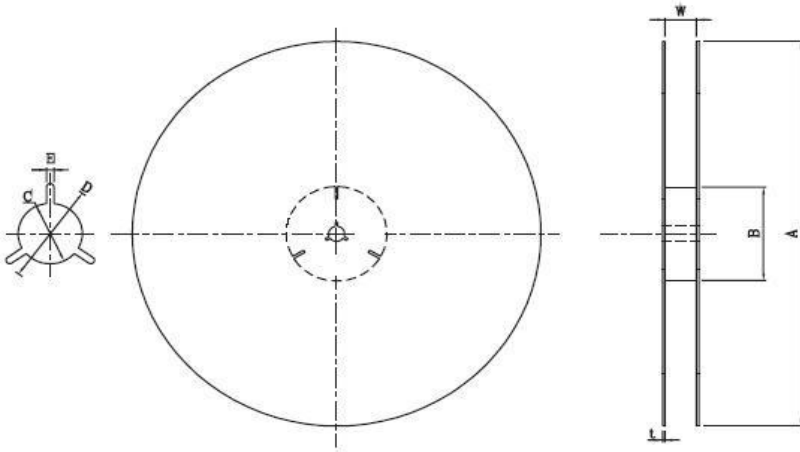

A: $\phi 180 \pm 1.0$	B: $\phi 60 \pm 1.0$	C: $\phi 13.0 \pm 0.5$	D: $\phi 12.0 \pm 1.0$
E: 1.9 ± 0.5	W: 25.5 ± 1.0		

NOTE: 1. packgeing q'ty 1000PCS /REEL
