



东莞市祥如电子有限公司

客户/CUSTOMER:

通用型 XRSQ1515

客户代码/CUSTOMER CODE:

承认书

SPECIFICATION FOR APPROVAL

产品名称/DESCRIPTION:

XRSQ 扁平线共模电感

客户型号/CUSTOMER MODEL:

XRSQ1515-20mH-V

客户编码/CUSTOMER CODING:

N/A

祥如型号/LUCKY TENDA MODEL:

XRSQ1515-20mH-V

版本/EDITION: A2

立式 8*10

日期/DATE: 2019/09/18

承制方确认/MANUFACTURER

使用方确认/CUSTOMER APPROVED

拟制 DRAWING	审核 CHECKED	批准 RATIFY

开发审核 R&D CHECKED	项目审核 ITEM CHECKED	工艺审核 TECHNOLOGY CHECKED	品质批准 QUALITY RATIFY

1. 安装尺寸及外形图/CONFIGURATION & DIMENSIONS UNIT:mm

PCB板孔径 $\geq \Phi 1.2\text{mm}$

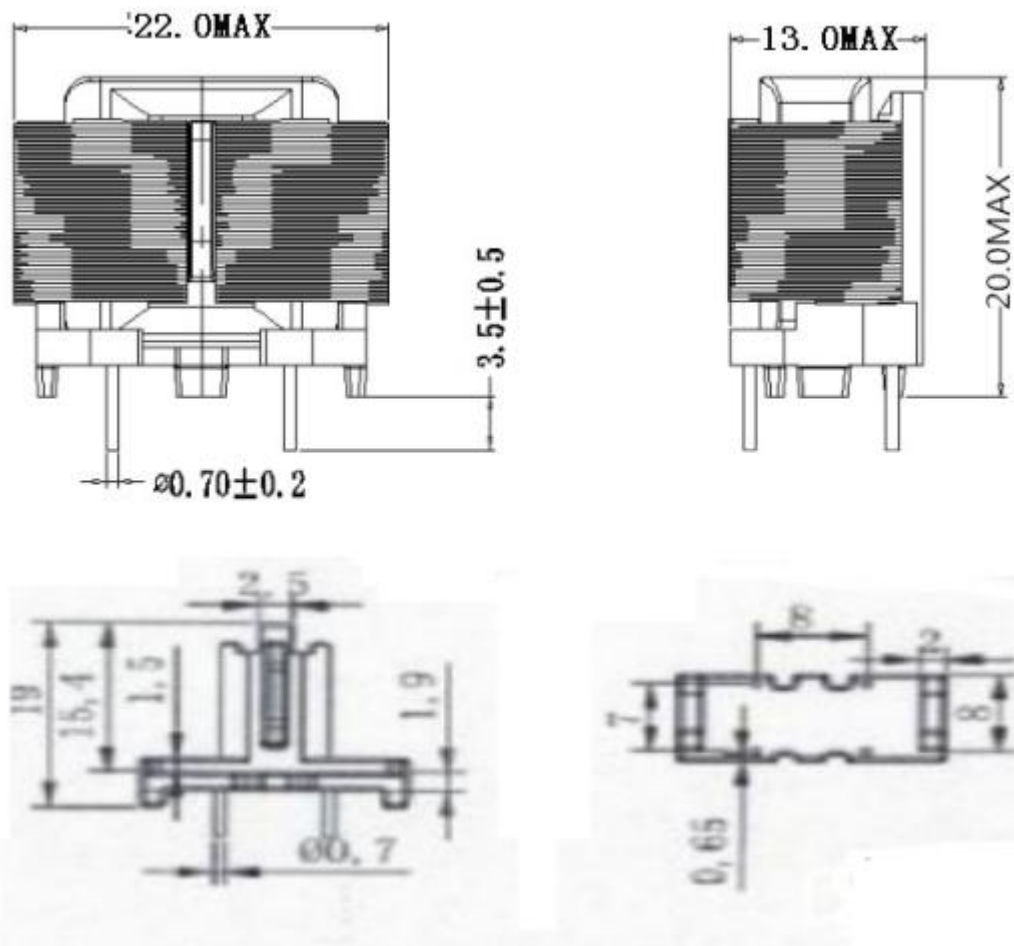

2. 内部结构图/WINDING CONSTRUCTION

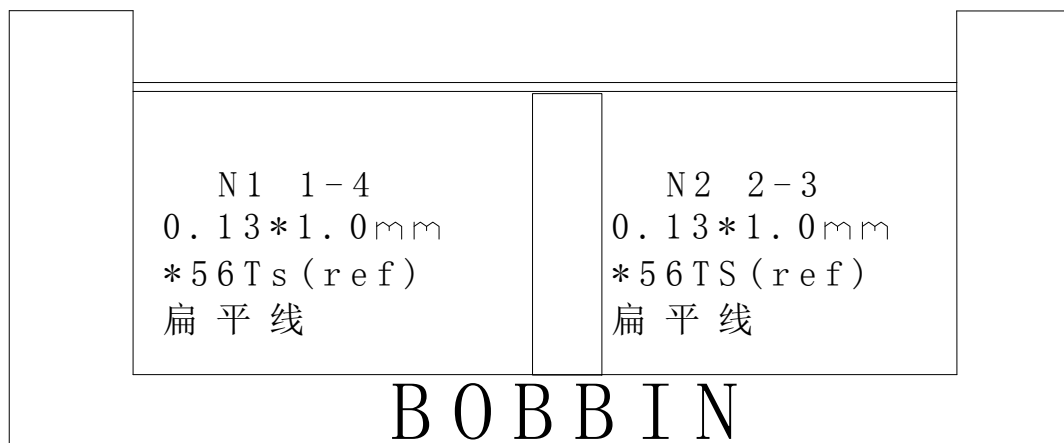

3. 线圈连线图/CONNECTION

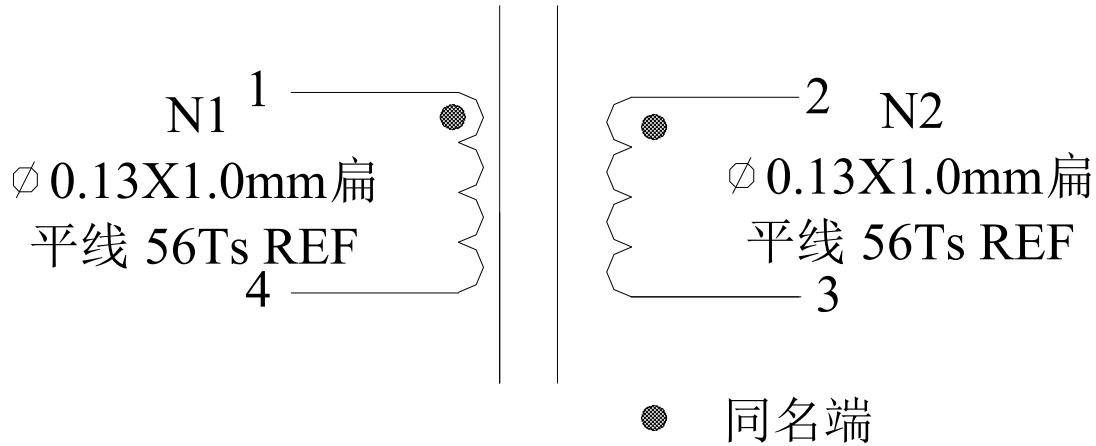

4. 绕制工艺要求/MANUFACTURE SPECIFICATION

1. 底座 (2+2), 磁芯为XRSQ1515磁芯;脚距: 8*10
2. 绕制顺序为: N1同时绕制N2;
3. 产品需浸油, 无铅制程;

5. 电气参数/ELECTRIC CHARACTER

序号 NO.	名称ITEMS	测量端 MEASURED POINT	测量值 TECHNICAL DATA	测试条件 TESTING CONDITION	测试仪器 APPARATUS
1	电感量 INDUCTANCE	$L_{1-4}=L_{2-3}$	20mH min	1KHz,0.25V 25°C	HP4284A 或内阻为 100Ω 测试仪
2	直流电阻 DC Resistance	$DCR_{1-4}=DCR_{2-3}$	250 mΩ MAX	1KHz,0.25V 25°C Short Other Pin	
3	抗电强度 HI-POT TEST	COIL 1 TO COIL 2	无击穿	1.5KVAc 5mA 3 SEC	CS9912BI
		COIL - CORE		1.0KVAc 5mA 3 SEC	
4	匝比 TURNS RATIO	N1:N2	56 (REF) :56	1KHz,0.25V	CH3250

拟制/DRAWING:	审核/CHECKED:	批准/RATIFY:
-------------	-------------	------------

6.包装、外观和检验要求/PACKAGE SEMBLABLE AND TEST REQUIREMENT

6.1 包装(PACKING REQUIREMENT)

①包装箱上标明产品型号、名称、数量、生产周期，出厂日期、承制方名称及出厂检验章；最小包装 1404PCS (TYPE ,PRODUCT NAME ,QTY,MANUFACTURE PERIOD ,SHIPPING DATE ,SUPPLIER NAME AND THE STAMP OF OUT-INSPECTION MUST BE STATED IN THE OUT PACKAGING.)

TD1515-L

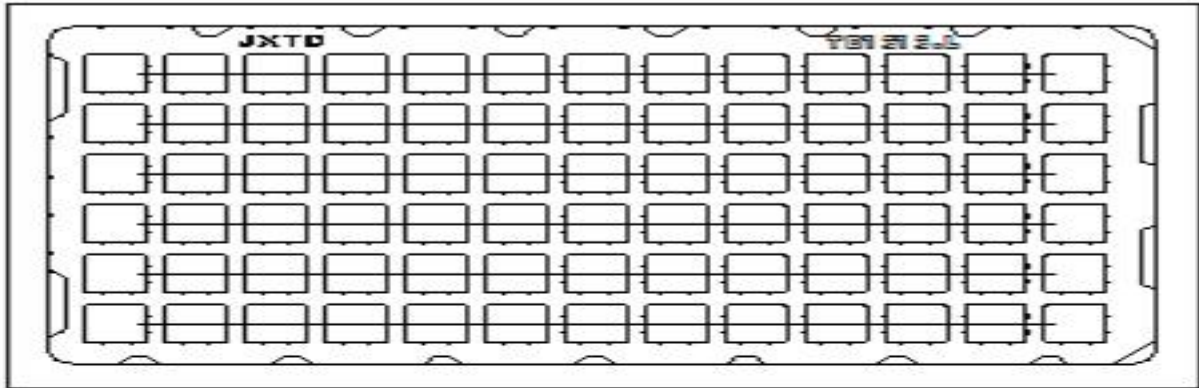

每箱两板，每板9层，每层13*6=78PCS

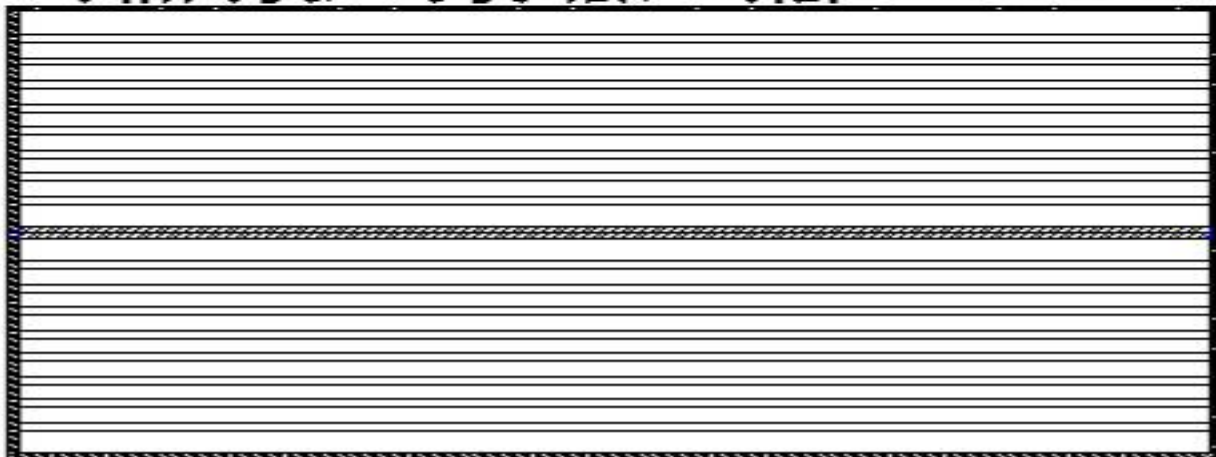

②不同生产周期的同一产品不得放入同一包装箱内；(THE SAME PRODUCT BUT DIFFERENT MANUFACTURE PERIOD NUMBER MUSTN'T BE PUT IN THE SAME CONTAINER)

③货物运达客户方后，包装箱封条应完好，箱体无破损、开裂等现象；(COMPLETE SEAL, NO BREAKAGE ON OUTER CONTAINER , NO CRACK IS REQUIRED WHEN THE CUSTOMER RECEIVED THE GOODS)

拟制/DRAWING:

审核/CHECKED:

批准/RATIFY:

客 户/CUSTOMER: T
承制方/MANUFACTURER: 祥如电子

型 号/MODEL: XRSQ1515-20mH
版本/EDITION: A2 第 5 页 共 8 页

④开箱后，箱内包装材料无破损。产品应分层、间隔包装，不满一箱应加垫填充物。(THE PACKING MATERIALS CAN'T HAVE ANY BREAKAGE WHEN OPENING THE CONTAINER . THE PRODUCTS SHOULD BE PACKED IN LAYER AND SPACER . IF THERE ARE NO ENOUGH PRODUCTS TO A CONTAINER , FILLER WILL BE PUT IN)

6.2 外观(APEARANCE REQUIREMENT)

①每件最小包装应有耐擦防水洗标签或印字，应注明生产周期、型号或规格；(THE LABEL OF WATERPROOF OR LETTERING SHOULD BE NEEDED ON EACH MINIMUM PACKING AND MANUFACTURE PERIOD ,TYPE OR SIZE SHOULD BE STATED)

②外观整洁。(KEEP THE APPEARANCE NEAT)

6.3 检验(CHECKING REQUIREMENT)

①产品生产时必须全数进行电气性能检测；(DURING PRODUCTION,ALL PRODUCTS MUST BE TESTED ELECTRIC CHACTER AND ELECTRICITY-RESISTANT INTENSITY)

②产品出货前按批次，必须根据承认书按国家行业标准进行抽样检验，合格后出具出厂检验报告，记录抽样测试数据。

(BEFORE SHIPPING , THE PRODUCT MUST BE HAD A SAMPLING TEST ACCORDING TO ACKNOWLEDGMENT BY NATIONAL INDUSTRY STANDARD . TEST REPORT WILL BE SHOWED AND THE DATE OF TESTING WILL BE NOTED AFTER QUALIFIED .)

拟制/DRAWING:

审核/CHECKED:

批准/RATIFY:

7. 材料清单/MATERIAL LIST

LIST1

ITEM	TYPE	MATERIAL	SPEC		MANUFACTURE	UL NO.
			°C	UL94		
WIRE	Φ0.13*1.0m m	1UEW	180	N/A	Guangdong liziwire Electric Technology Co LXRSQ	E504985
					YOU TUO ENTERPRISE CO.,LXRSQ	E338133
Varnish	1032XXX				Shen zhen noble flower technology industrial co LXRSQ	E213437

LIST 2

ITEM	TYPE	PRODUCT MANUFACTURE	MATERIAL	SPEC		MATERIAL MANUFACTURE	UL NO.	ROHS
				°C	UL94			
BOBBIN	XRSQ15底 座	MEIRISHENG ELECTRONICS CO; LXRSQ	T375HF	150	V-0	CHANG CHUN PLASTICS CO LXRSQ	E59481	Y

LIST 3

ITEM	TYPE	MATERIAL	SPEC		MANUFACTURE
			°C	UL94	
CORE	XRSQ15	R12K	N/A	N/A	Shan Dong Heng Rui Magent technolgy co.,LXRSQ
		R12K OR EQUIVALENT			ACME Electronics(guangzhou) Co.,LXRSQ
					JIU XIN

4. 存储条件: 温度-10~40℃ 相对湿度: 30~70%,
 禁止将产品保管在腐蚀性物质中, 如硫磺, 氯气或酸, 否则将引起端头氧化, 导致降低焊接性.
 为了避免受潮气, 灰尘等物质的影响, 产品应保管于货架上.
 产品保管在库房中, 应避免热冲击, 振动以及直接光照等.

更改说明/REJIGGER EXPLAIN:

序号 SERIAL	更改地方 REJIGGER PLACE	更改原因 REJIGGER CAUSATION	责任归属 RESPONSIBILITY BELONG TO	更改收益 REJIGGER INCOME

客户/CUSTOMER: T
 承制方/MANUFACTURER: 祥如电子

型号/MODEL: XRSQ1515-20mH
 版本/EDITION: A2 第 7 页 共 8 页

检 验 报 告

MEAS. ITEM		L(1-4) mH	L(2-3) mH	DCR(1-4) mΩ	DCR(2-3) mΩ	LK1-4 短路 L(2-3)	
SPEC.	YOUR						
	SUGGEST	20 min	20min	250MAX	250MAX	漏感	
TEST FREQ.		1KHz/0.25V	1KHz/0.25V	内阻 100Ω	内阻 100Ω	1KHZ/0.25V	
1		35.69	35.65	209	209	140uH	
2		30.22	30.23	208	208	140uH	
3		35.82	35.84	208	208	139uH	
4		38.91	38.90	209	209	139uH	
5		30.56	30.56	208	208	140uH	
6		35.45	35.50	209	209	140uH	
7		33.29	33.29	208	208	140uH	
8		32.86	32.88	209	209	140uH	
YOUR SAMPLE							
TEST CONDITION: TEMP.: 25°C (REF.) R.H.: 60% (REF.)							
REMARK: HI-POT TEST OK							

拟制/DRAWING:	审核/CHECKED:	批准/RATIFY:
-------------	-------------	------------

材质特性与特性曲线

特性 Characteristics	符号 Symbol	单位 Unit	特性值 Value
初始磁导率 Initial permeability	μ_i		12000 ± 25%
饱和磁通密度 (H=1194A/m) Saturation flux density	B_s	mT	380
比损耗因子 Relative loss factor	$\tan \delta / \mu_i$	$\times 10^{-6}$	< 7(10kHz)
比温度系数 (25℃-60℃) Relative temperature coefficient	α / μ_i	$\times 10^{-6}/^{\circ}\text{C}$	-0.5~2.0
减落因子 Disaccommodation factor	DF	$\times 10^{-6}$	< 2
剩磁(H=1194A/m) Remanence	B_r	mT	110
矫顽力(H=1194A/m) Coercivity	H_c	A/m	5
居里温度 Curie temperature	T_c	℃	≥ 110
电阻率 Resistivity	ρ	$\Omega \cdot \text{m}$	0.15
密度 Density	d	kg/m^3	4.95×10^3

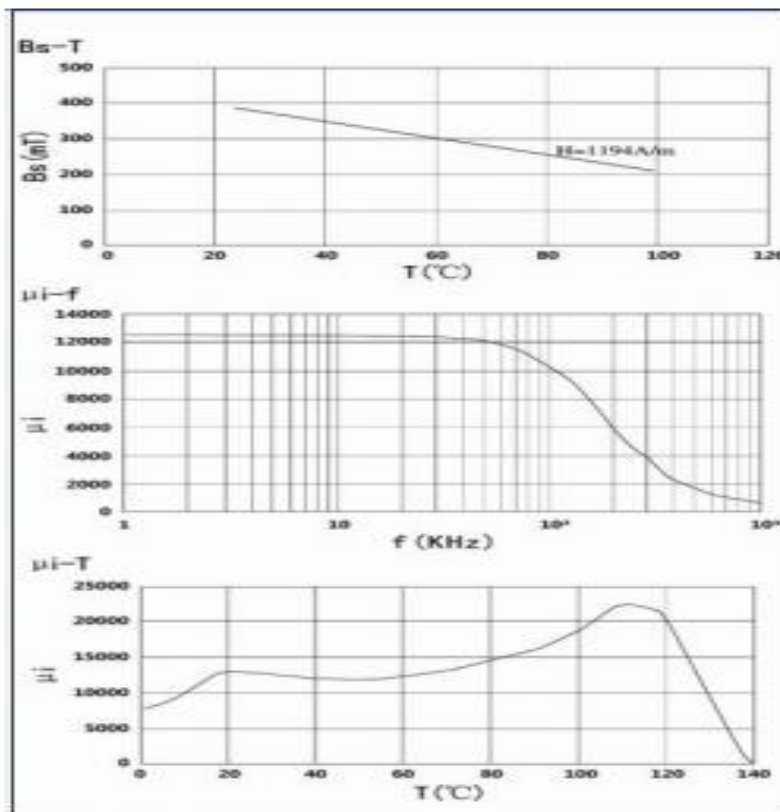

拟制/DRAWING:

审核/CHECKED:

批准/RATIFY: