



# 东莞市祥如电子有限公司

客户/CUSTOMER:

通用型 XRSQ1212 立式

客户代码/CUSTOMER CODE:

## 承认书

**SPECIFICATION FOR APPROVAL**

产品名称/DESCRIPTION:

XRSQ 扁平线共模电感

客户型号/CUSTOMER MODEL:

XRSQ1212-20mH-V

客户编码/CUSTOMER CODING:

N/A

祥如型号/LUCKY TENDA MODEL:

XRSQ1212-20mH-V

版本/EDITION: A0

立式: 7\*8

日期/DATE: 2022/05/09

承制方确认/MANUFACTURER

使用方确认/CUSTOMER APPROVED

拟制 DRAWING	审核 CHECKED	批准 RATIFY

开发审核 R&D CHECKED	项目审核 ITEM CHECKED	工艺审核 TECHNOLOGY CHECKED	品质批准 QUALITY RATIFY

1. 安装尺寸及 外形图 /CONFIGRATION & DIMENSIONS UNIT:mm.

PCB板孔径 ≥ Φ 1.4mm

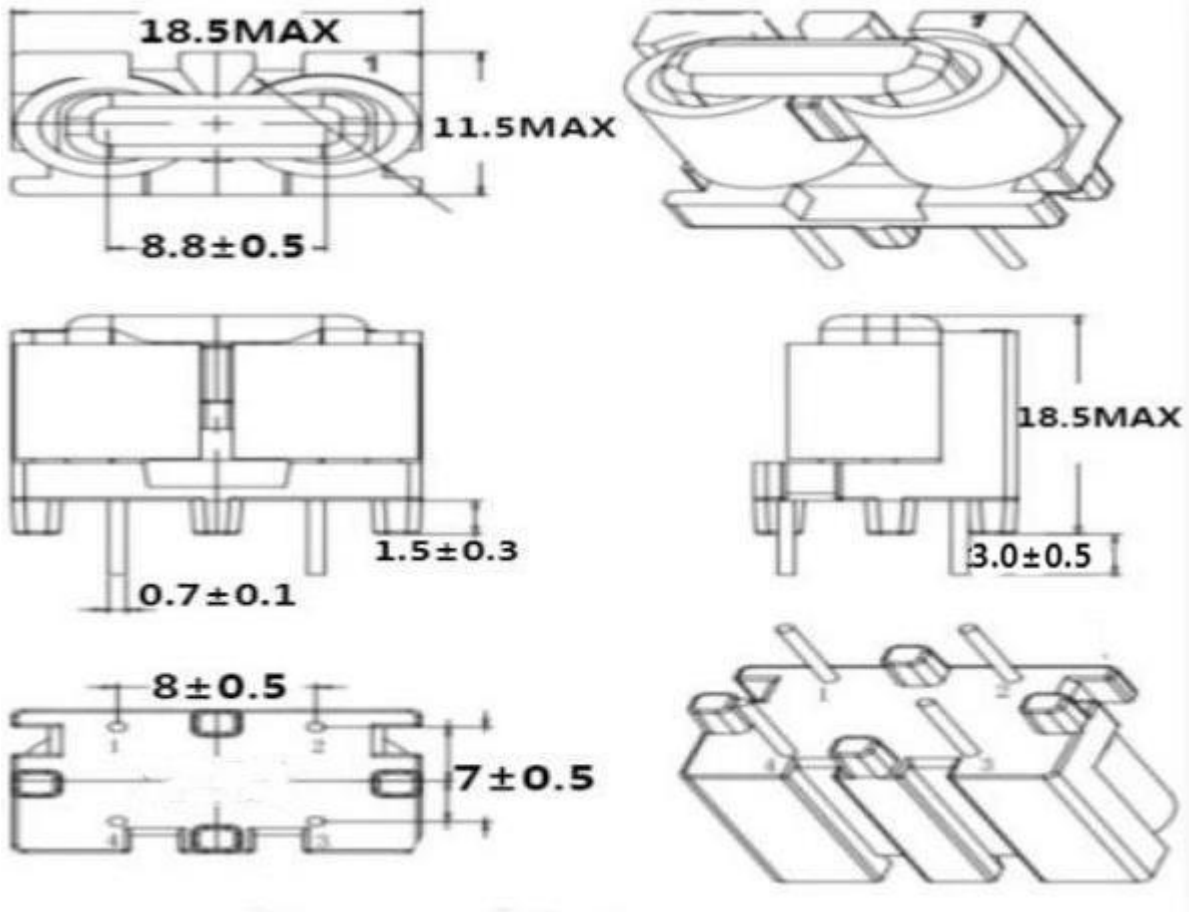

2. 内部结构图/WINDING CONSTRUCTION

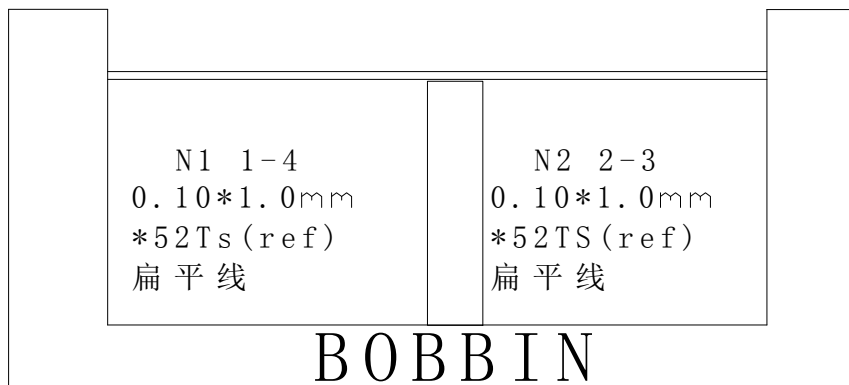

### 3. 线圈连线图/CONNECTION

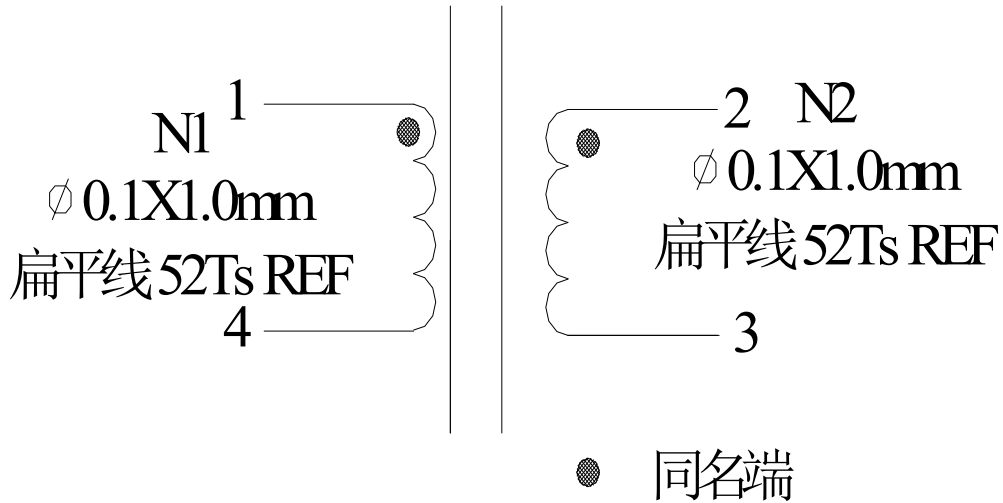

### 4. 绕制工艺要求/MANUFACTURE SPECIFICATION

1. 底座 (2+2), 磁芯为XRSQ1212磁芯;
2. 绕制顺序为: N1同时绕制N2;
3. 产品需浸油, 无铅制程;

### 5. 电气参数/ELECTRIC CHARACTER

序号 NO.	名称ITEMS	测量端 MEASURED POINT	测量值 TECHNICAL DATA	测试条件 TESTING CONDITION	测试仪器 APPARATUS
1	电感量 INDUCTANCE	$L_{1-4}=L_{2-3}$	20mH min	1KHz,0.25V 25°C	HP4284A 或内阻为 100Ω 测试仪
2	直流电阻 DC Resistance	$DCR_{1-4}=DCR_{2-3}$	240 mΩ MAX	1KHz,0.25V SER Short Other Pin	
3	抗电强度 HI-POT TEST	COIL 1 TO COIL 2	无击穿	1.5KVAc 5mA 3 SEC	CS9912BI
		COIL - CORE		1.0KVAc 5mA 3 SEC	
4	匝比 TURNS RATIO	N1:N2	52 (REF) :52	1KHz,0.25V	CH3250

拟制/DRAWING:	审核/CHECKED:	批准/RATIFY:
-------------	-------------	------------

客 户/CUSTOMER:

型 号/MODEL: XRSQ1212-20mH

承制方/MANUFACTURER: 祥如电子

版本/EDITION: A0

第 4 页 共 8 页

## 6.包装、外观和检验要求/PACKAGE SEMBLABLE AND TEST REQUIREMENT

### 6.1 包装(PACKING REQUIREMENT)

①包装箱上标明产品型号、名称、数量、生产周期，出厂日期、承制方名称及出厂检验章；最小包装 1995PCS (TYPE ,PRODUCT NAME ,QTY,MANUFACTURE PERIOD ,SHIPPING DATE ,SUPPLIER NAME AND THE STAMP OF OUT-INSPECTION MUST BE STATED IN THE OUT PACKAGING.)

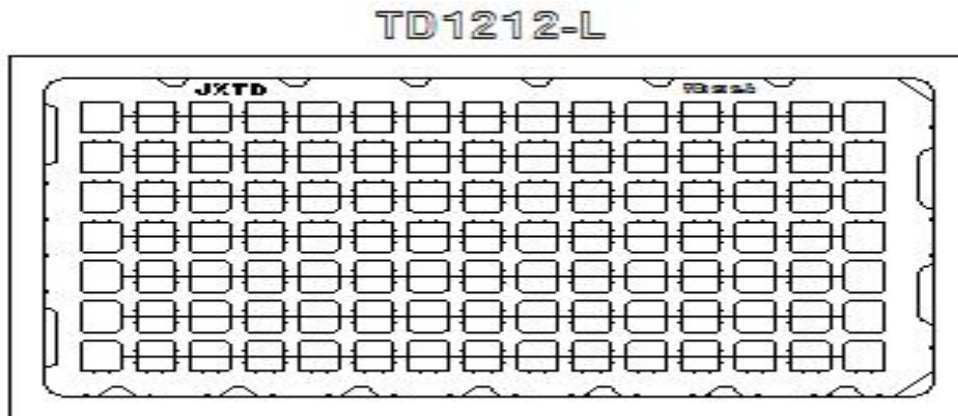

**每箱两板，1板10层，1板9层，每层15\*7=105PCS**

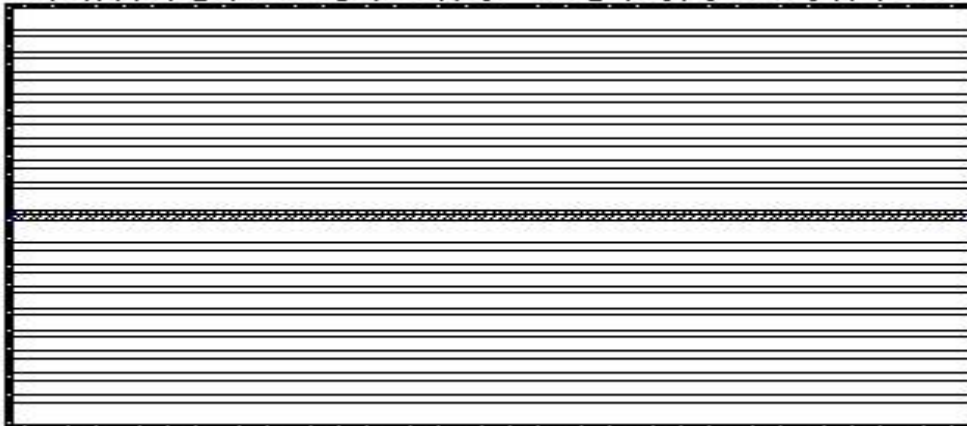

②不同生产周期的同一产品不得放入同一包装箱内；(THE SAME PRODUCT BUT DIFFERENT MANUFACTURE PERIOD NUMBER MUSTN'T BE PUT IN THE SAME CONTAINER)

③货物运达客户方后，包装箱封条应完好，箱体无破损、开裂等现象；(COMPLETE SEAL, NO BREAKAGE ON OUTER CONTAINER , NO CRACK IS REQUIRED WHEN THE CUSTOMER RECEIVED THE GOODS)

拟制/DRAWING:

审核/CHECKED:

批准/RATIFY:

客 户/CUSTOMER:

型 号/MODEL: XRSQ1212-20mH

承制方/MANUFACTURER: 祥如电子

版本/EDITION: A0

第 5 页 共 8 页

④开箱后,箱内包装材料无破损。产品应分层、间隔包装,不满一箱应加垫填充物。(THE PACKING MATERIALS CAN'T HAVE ANY BREAKAGE WHEN OPENING THE CONTAINER . THE PRODUCTS SHOULD BE PACKED IN LAYER AND SPACER . IF THERE ARE NO ENOUGH PRODUCTS TO A CONTAINER , FILLER WILL BE PUT IN )

## 6.2 外观(APPEARANCE REQUIREMENT)

①每件最小包装应有耐擦防水洗标签或印字,应注明生产周期、型号或规格;(THE LABEL OF WATERPROOF OR LETTERING SHOULD BE NEEDED ON EACH MINIMUM PACKING AND MANUFACTURE PERIOD ,TYPE OR SIZE SHOULD BE STATED)

②外观整洁。( KEEP THE APPEARANCE NEAT )

## 6.3 检验(CHECKING REQUIREMENT)

①产品生产中必须全数进行电气性能检测;(DURING PRODUCTION,ALL PRODUCTS MUST BE TESTED ELECTRIC CHACTER AND ELECTRICITY-RESISTANT INTENSITY )

②产品出货前按批次,必须根据承认书按国家行业标准进行抽样检验,合格后出具出厂检验报告,记录抽样测试数据。

( BEFORE SHIPPING , THE PRODUCT MUST BE HAD A SAMPLING TEST ACCORDING TO ACKNOWLEDGMENT BY NATIONAL INDUSTRY STANDARD . TEST REPORT WILL BE SHOWED AND THE DATE OF TESTING WILL BE NOTED AFTER QUALIFIED . )

拟制/DRAWING:

审核/CHECKED:

批准/RATIFY:

## 7. 材料清单/MATERIAL LIST

### LIST1

ITEM	TYPE	MATERIAL	SPEC		MANUFACTURE	UL NO.
			℃	UL94		
WIRE	Φ0.10*1.0m m	1UEW	180	N/A	Guangdong liziwire Electric Technology Co LXRSQ	E504985
					YOU TUO ENTERPRISE CO.,LXRSQ	E338133
Varnish	1032XXX				Shen zhen noble flower technology industrial co LXRSQ	E213437

### LIST 2

ITEM	TYPE	PRODUCT MANUFACTURE	MATERIAL	SPEC		MATERIAL MANUFACTURE	UL NO.	ROHS
				℃	UL94			
BOBBIN	XRSQ12底座	MEIRISHENG ELECTRONICS CO; LXRSQ	T375HF	150	V-0	CHANG CHUN PLASTICS CO LXRSQ	E59481	Y

### LIST 3

ITEM	TYPE	MATERIAL	SPEC		MANUFACTURE
			℃	UL94	
CORE	XRSQ12	R12K	N/A	N/A	ShanDongHengRui Magent technolgy co.,LXRSQ
		R12K OR EQUIVALENT			ACME Electronics(guangzhou) Co.,LXRSQ

### 更改说明/REJIGGER EXPLAIN:

序号 SERIAL	更改地方 REJIGGER PLACE	更改原因 REJIGGER CAUSATION	责任归属 RESPONSIBILITY BELONG TO	更改收益 REJIGGER INCOME

## 检 验 报 告

MEAS. ITEM		L(1-4) mH	L(2-3) mH	DCR(1-4) mΩ	DCR(2-3) mΩ	Lk1-4 短路 L(2-3)	
SPEC.	YOUR						
	SUGGEST	15min	15min	240MAX	240MAX	漏感	
TEST FREQ.		1KHz/0.25V	1KHz/0.25V	内阻 100Ω	内阻 100Ω	1KHZ/0.25V	
	1	42.8	42.8	197	197	95.4uH	
	2	38.9	38.9	199	199	93.5uH	
	3	39.8	39.8	198	198	95.0uH	
	4	38.7	38.7	199	199	95.4uH	
	5	38.9	38.9	199	199	95.0uH	
	6	40.1	40.1	198	198	95.4uH	
	7	35.6	35.6	198	198	95.4uH	
	8	38.8	38.8	198	198	93.3uH	
YOUR SAMPLE							

TEST CONDITION:                      TEMP.:    25°C (REF.)                      R.H.:    60% (REF.)

REMARK:    HI-POT TEST OK

R12K

特性 Characteristics	符号 Symbol	单位 Unit	特性值 Value
初始磁导率 Initial permeability	$\mu_i$		12000 ± 25%
饱和磁通密度 (H=1194A/m) Saturation flux density	$B_s$	mT	380
比损耗因子 Relative loss factor	$\tan \delta / \mu_i$	$\times 10^{-6}$	< 7 (10kHz)
比温度系数 (25℃~60℃) Relative temperature coefficient	$\alpha / \mu_i$	$\times 10^{-6}/^\circ\text{C}$	-0.5~2.0
减落因子 Disaccommodation factor	DF	$\times 10^{-6}$	< 2
剩磁(H=1194A/m) Remanence	$B_r$	mT	110
矫顽力(H=1194A/m) Coercivity	$H_c$	A/m	5
居里温度 Curie temperature	$T_c$	℃	$\geq 110$
电阻率 Resistivity	$\rho$	$\Omega \cdot \text{m}$	0.15
密度 Density	d	kg/m <sup>3</sup>	$4.95 \times 10^3$

Bs-T

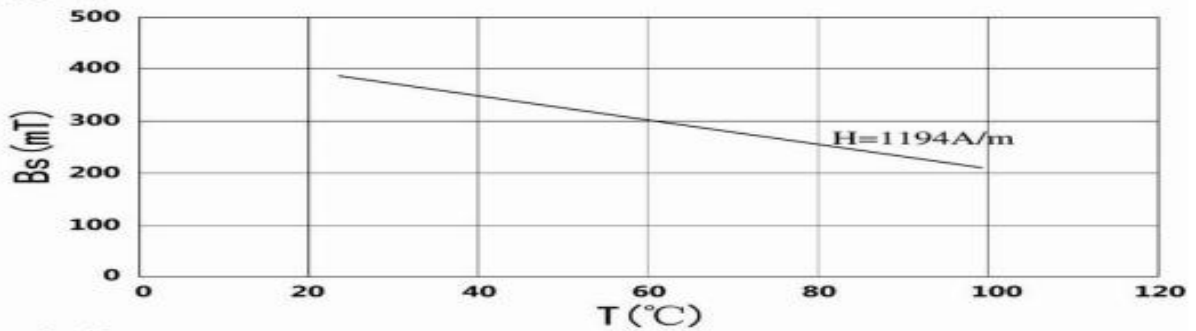

$\mu_i$ -f

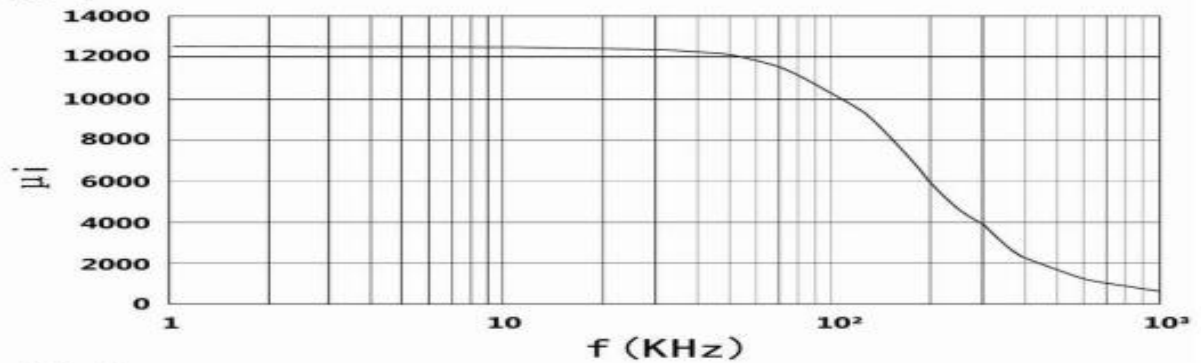

$\mu_i$ -T

