



客户/CUSTOMER: 通用型 XRSQ1212 卧式

客户代码/CUSTOMER CODE: T

承认书

SPECIFICATION FOR APPROVAL

产品名称/DESCRIPTION:	XRSQ 扁平线共模电感
客户型号/CUSTOMER MODEL:	XRSQ1212-20mH-H
客户编码/CUSTOMER CODING:	N/A
祥如型号/LUCKY TENDA MODEL:	XRSQ1212-20mH-H
版本/EDITION: A2	卧式: 10*13
日期/DATE: 2019/07/22	

承制方确认/MANUFACTURER

使用方确认/CUSTOMER APPROVED

拟制 DRAWING	审核 CHECKED	批准 RATIFY

开发审核 R&D CHECKED	项目审核 ITEM CHECKED	工艺审核 TECHNOLOGY CHECKED	品质批准 QUALITY RATIFY

安装尺寸及外形图/CONFIGURATION & DIMENSIONS UNIT:mm

拟制/DRAWING:	审核/CHECKED:	批准/RATIFY:
-------------	-------------	------------

PCB板孔径 $\geq \Phi 1.2\text{mm}$

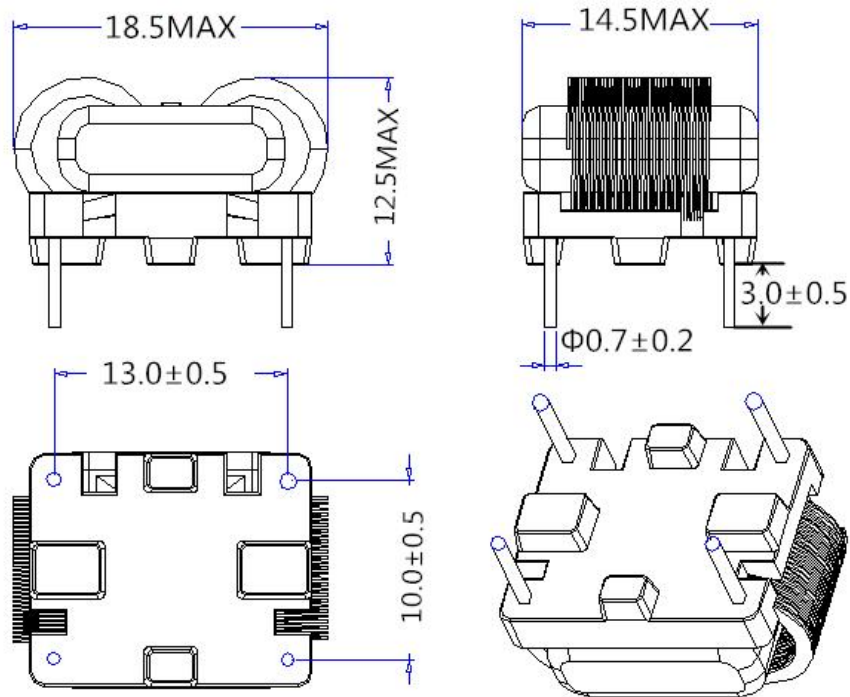

丝印说明：底部丝印标识为产品骨架标识，底部有三种丝印方式参考如下：

- 1: XRSQ XX (XRSQ 为产品骨架型号, XX 标示模具号)
- 2: XRSQ-1212 AA (XRSQ-1212 为产品骨架型号, AA 标示模具号)
- 3: 无编码 (底部无印字)

2. 内部结构图/WINDING CONSTRUCTION

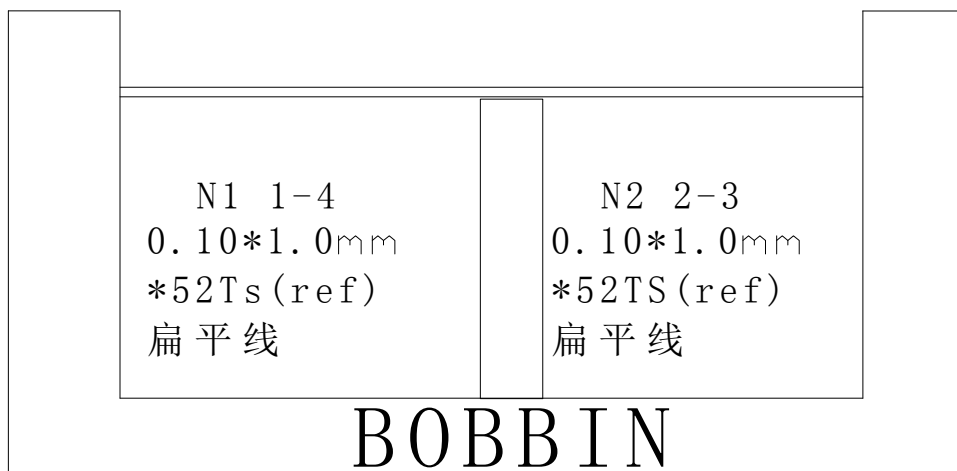

3. 线圈连线图/CONNECTION

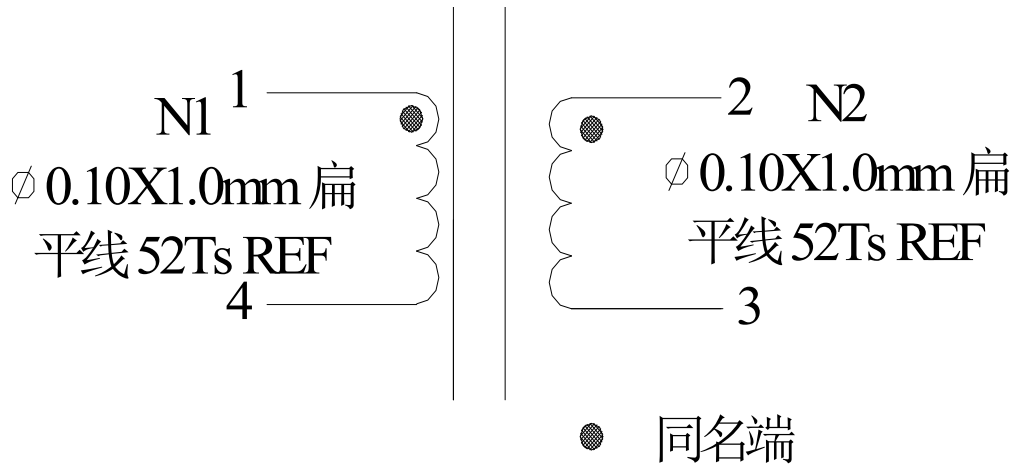

4. 绕制工艺要求/MANUFACTURE SPECIFICATION

1. 底座 (2+2), 磁芯为XRSQ1212磁芯;
2. 绕制顺序为: N1同时绕制N2;
3. 产品需浸油, 无铅制程;

5. 电气参数/ELECTRIC CHARACTER

序号 NO.	名称 ITEMS	测量端 MEASURED POINT	测量值 TECHNICAL DATA	测试条件 TESTING CONDITION	测试仪器 APPARATUS
1	电感量 INDUCTANCE	$L_{1-4}=L_{2-3}$	20mH min	1KHz, 0.25V 25°C	HP4284A 或内阻为 100Ω 测试仪
2	直流电阻 DC Resistance	$DCR_{1-4}=DCR_{2-3}$	240 mΩ MAX	1KHz, 0.25V SER Short Other Pin	
3	抗电强度 HI-POT TEST	COIL 1 TO COIL 2	无击穿	1.5kVAc 5mA 3 SEC	CS9912BI
		COIL - CORE		1.0kVAc 5mA 3 SEC	
4	匝比 TURNS RATIO	N1:N2	52 (REF) :52	1KHz, 0.25V	CH3250

拟制/DRAWING:	审核/CHECKED:	批准/RATIFY:
-------------	-------------	------------

6.包装、外观和检验要求/PACKAGE SEMBLABLE AND TEST REQUIREMENT

6.1 包装(PACKING REQUIREMENT)

①包装箱上标明产品型号、名称、数量、生产周期, 出厂日期、承制方名称及出厂检验章; 最小包装数 2176PCS (TYPE ,PRODUCT NAME ,QTY,MANUFACTURE PERIOD ,SHIPPING DATE ,SUPPLIER NAME AND THE STAMP OF OUT-INSPECTION MUST BE STATED IN THE OUT PACKAGING.)

②不同生产周期的同一产品不得放入同一包装箱内; (THE SAME PRODUCT BUT DIFFERENT MANUFACTURE PERIOD NUMBER MUSTN'T BE PUT IN THE SAME CONTAINER)

③货物运达客户方后, 包装箱封条应完好, 箱体无破损、开裂等现象; (COMPLETE SEAL, NO BREAKAGE ON OUTER CONTAINER , NO CRACK IS REQUIRED WHEN THE CUSTOMER RECEIVED THE GOODS)

④开箱后, 箱内包装材料无破损。产品应分层、间隔包装, 不满一箱应加垫填充物。(THE PACKING MATERIALS CAN'T HAVE ANY BREAKAGE WHEN OPENING THE CONTAINER . THE PRODUCTS SHOULD BE PACKED IN LAYER AND SPACER . IF THERE ARE NO ENOUGH PRODUCTS TO A CONTAINER , FILLER WILL BE PUT IN)

6.2 外观(APPEARANCE REQUIREMENT)

①每件最小包装应有耐擦防水洗标签或印字, 应注明生产周期、型号或规格; (THE LABEL OF WATERPROOF OR LETTERING SHOULD BE NEEDED ON EACH MINIMUM PACKING AND MANUFACTURE PERIOD ,TYPE OR SIZE SHOULD BE STATED)

②外观整洁。(KEEP THE APPEARANCE NEAT)

6.3 检验(CHECKING REQUIREMENT)

拟制/DRAWING:	审核/CHECKED:	批准/RATIFY:
-------------	-------------	------------

客 户/CUSTOMER: T	型 号/MODEL: XRSQ1212-20mH
承制方/MANUFACTURER: 祥如电子	版本/EDITION: A 2 第 5 页 共 8 页

①产品生产时必须全数进行电气性能检测；(DURING PRODUCTION,ALL PRODUCTS MUST BE TESTED ELECTRIC CHACTER AND ELECTRICITY-RESISTANT INTENSITY)

②产品出货前按批次，必须根据承认书按国家行业标准进行抽样检验，合格后出具出厂检验报告，记录抽样测试数据。

(BEFORE SHIPPING , THE PRODUCT MUST BE HAD A SAMPLING TEST ACCORDING TO ACKNOWLEDGMENT BY NATIONAL INDUSTRY STANDARD . TEST REPORT WILL BE SHOWED AND THE DATE OF TESTING WILL BE NOTED AFTER QUALIFIED .)

7. 材料清单/MATERIAL LIST

LIST1

ITEM	TYPE	MATERIAL	SPEC		MANUFACTURE	UL NO.
			°C	UL94		
WIRE	Φ0.1*1.0mm	1UEW	180	N/A	Guangdong liziwire Electric Technology Co LXRSQ	E504985
					YOU TUO ENTERPRISE CO.,LXRSQ	E338133
Varnish	1032XXX				Shen zhennoble flower technology industrial co LXRSQ	E213437

LIST 2

ITEM	TYPE	PRODUCT MANUFACTURE	MATERIAL	SPEC		MATERIAL MANUFACTURE	UL NO.	ROHS
				°C	UL94			
BOBBIN	XRSQ12底座	MEIRISHENG ELECTRONICS CO; LXRSQ	T375HF	150	V-0	CHANG CHUN PLASTICS CO LXRSQ	E59481	Y

拟制/DRAWING:	审核/CHECKED:	批准/RATIFY:
-------------	-------------	------------

LIST 3

ITEM	TYPE	MATERIAL	SPEC		MANUFACTURE
			℃	UL94	
CORE	XRSQ12	R12K	N/A	N/A	ShanDongHengRui Magent technolgy co.,IXRSQ
		R12K OR EQUIVALENT			ACME Electronics(guangzhou) Co.,LXRSQ
					JIU XIN

4. 存储条件: 温度-10~40℃ 相对湿度: 30~70%,

禁止将产品保管在腐蚀性物质中, 如硫磺, 氯气或酸, 否则将引起端头氧化, 导致降低焊接性. 为了避免受潮气, 灰尘等物质的影响, 产品应保管于货架上. 产品保管在库房中, 应避免热冲击, 振动以及直接光照等.

更改说明/REJIGGER EXPLAIN:

序号 SERIAL	更改地方 REJIGGER PLACE	更改原因 REJIGGER CAUSATION	责任归属 RESPONSIBILITY BELONG TO	更改收益 REJIGGER INCOME

检 验 报 告

MEAS. ITEM		L(1-4) mH	L(2-3) mH	DCR(1-4) mΩ	DCR(2-3) mΩ	LK1-4 短路 L(2-3)	
SPEC.	YOUR						
	SUGGEST	15 min	15min	240MAX	240MAX	漏感	
TEST FREQ.		1KHz/0.25V	1KHz/0.25V	内阻 100Ω	内阻 100Ω	1KHZ/0.25V	
1		32.6	32.65	196	195	93.0uH	
2		37.5	37.5	195	196	93.4uH	
3		35.7	35.7	195	195	93.2uH	
4		36.2	36.2	195	195	94.5uH	
5		35.6	35.6	196	196	94.2uH	
6		40.6	40.6	196	196	93.6uH	
7		37.2	37.2	195	195	95.6uH	
8		34.6	34.6	195	195	93.6uH	
YOUR SAMPLE							

TEST CONDITION: TEMP.: 25°C (REF.) R.H.: 60% (REF.)

REMARK: HI-POT TEST OK

R12K

特性 Characteristics	符号 Symbol	单位 Unit	特性值 Value
初始磁导率 Initial permeability	μ_i		12000 ± 25%
饱和磁通密度 (H=1194A/m) Saturation flux density	B_s	mT	380
比损耗因子 Relative loss factor	$\tan \delta / \mu_i$	$\times 10^{-6}$	< 7 (10kHz)
比温度系数 (25℃~60℃) Relative temperature coefficient	α / μ_i	$\times 10^{-6}/^\circ\text{C}$	-0.5~2.0
减落因子 Disaccommodation factor	DF	$\times 10^{-6}$	< 2
剩磁(H=1194A/m) Remanence	B_r	mT	110
矫顽力(H=1194A/m) Coercivity	H_c	A/m	5
居里温度 Curie temperature	T_c	℃	≥ 110
电阻率 Resistivity	ρ	$\Omega \cdot \text{m}$	0.15
密度 Density	d	kg/m ³	4.95×10^3

Bs-T

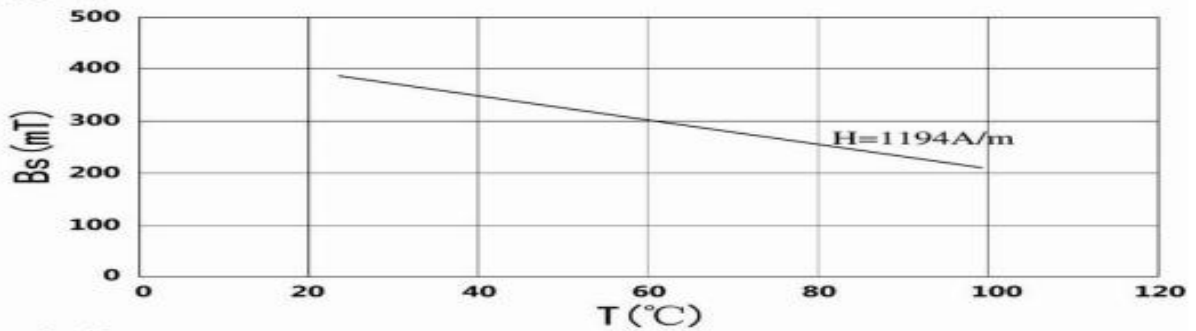

μ_i -f

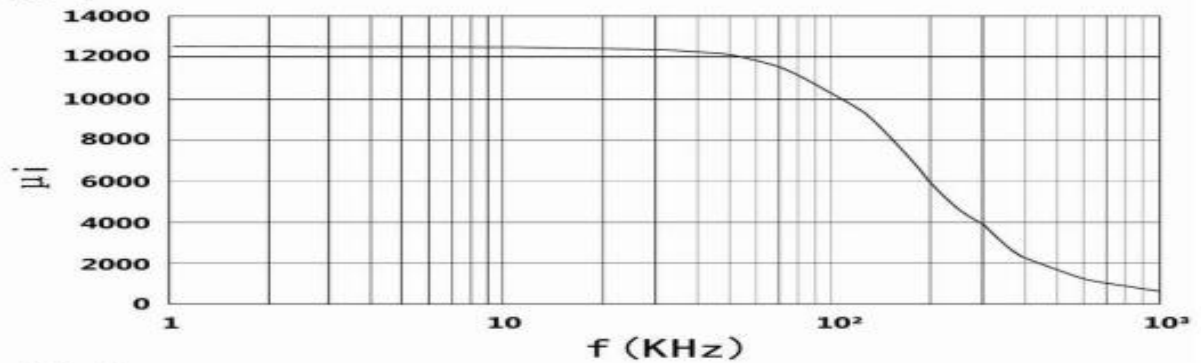

μ_i -T

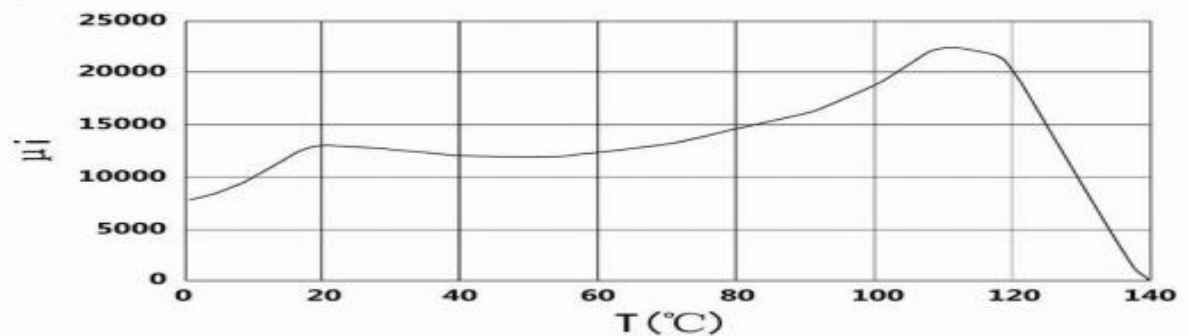

拟制/DRAWING:

审核/CHECKED:

批准/RATIFY: