





# 东莞市祥如电子有限公司

DONGGUAN XIANGRU ELECTRONICS CO., LTD

## 产品承认书

### SPECIFICATION FOR APPROVAL

|                        |               |                       |                         |
|------------------------|---------------|-----------------------|-------------------------|
| 客户名称<br>CUSTOMER       |               | 日期<br>DATE            | 2023-02-09              |
| 客户物料编号<br>CUSTOMER P/N |               | 客户规格型号<br>DESCRIPTION | 8*10-330UH 脚长15MM 0.28线 |
| 我司物料编号<br>OUR PARTNO   | XR8*10-331K-L | 我司品名<br>OUR PART NAME | 立式工字电感                  |

#### 外观尺寸 Appearance of size

单位 Unit: mm

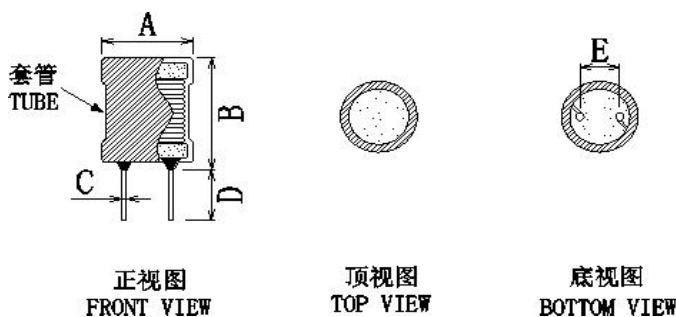

|                   |          |   |          |   |         |  |  |
|-------------------|----------|---|----------|---|---------|--|--|
| A                 | 9.5 MAX  | C | 0.6±0.1  | E | 5.0±0.5 |  |  |
| B                 | 12.5 MAX | D | 15.0±2.0 |   |         |  |  |
| 标识 Identification |          |   |          |   |         |  |  |

#### 原理图 Schematic Diagram

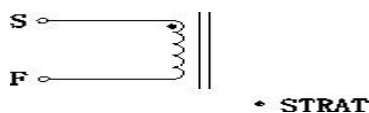

#### 绕线结构表 Winding Structure Diagram

| 绕组<br>WINDING | 起始<br>S | 结束<br>F | 漆包线<br>WIRE | 圈数<br>TURNS |      | 绕制方式<br>WINDINGWAY |  |  |
|---------------|---------|---------|-------------|-------------|------|--------------------|--|--|
| N1            | S       | F       | 2UEW-0.28mm | 98.5TS      | 圈数参考 | 平整密绕               |  |  |
|               |         |         |             |             |      |                    |  |  |
|               |         |         |             |             |      |                    |  |  |

#### 注意事项 Matters needing attention:

用少字套管

# 东莞市祥如电子有限公司

## DONGGUAN XIANGRU ELECTRONICS CO., LTD

### 产品承认书

### SPECIFICATION FOR APPROVAL

|                        |               |                       |                         |
|------------------------|---------------|-----------------------|-------------------------|
| 客户名称<br>CUSTOMER       |               | 日期<br>DATE            | 2023-02-09              |
| 客户物料编号<br>CUSTOMER P/N |               | 客户规格型号<br>DESCRIPTION | 8*10-330UH 脚长15MM 0.28线 |
| 我司物料编号<br>OUR PART NO  | XR8*10-331K-L | 我司品名<br>OUR PART NAME | 立式工字电感                  |

### 电性参数 Electrical parameters

| 测试项目<br>TEST PROJECT | 电性范围<br>SPEC | 测试条件<br>TEST FREQ | 测试仪器<br>TEST STRUMENTS |
|----------------------|--------------|-------------------|------------------------|
| 电感量L                 | 330uH ±10%   | at 25°C1KHz/0.25V | TH2829A                |
| 直流电阻DCR              | 1.0Ω MAX     | at 25°C1KHz/0.25V | TH2829A                |
|                      |              |                   |                        |
|                      |              |                   |                        |
|                      |              |                   |                        |

### 物料清单 BOM

| 物料<br>MATERIAL | 规格型号<br>SPECIFICATIONS        | 制造厂商<br>MANUFACTURERS  | UL证书号<br>UL FILE NO |
|----------------|-------------------------------|------------------------|---------------------|
| CORE           | MgZn DR2W8*10                 | LIANXING               |                     |
|                |                               | OR Equivalent supplier |                     |
| WIRE           | 2UEW-B(QA)                    | GANYUE HENGXING        | E233255             |
|                |                               | OR Equivalent supplier |                     |
| PIN            | Tinned copper clad steel wire | BAICHUAN               |                     |
|                |                               | OR Equivalent supplier |                     |
| TUBE           | UL HEAT-SHRINKABLE TUBE/125°C | XINGQI                 | E350991             |
|                |                               | OR Equivalent supplier |                     |
| EPOXY RESIN    | FK661                         | QI FU                  |                     |
|                |                               | OR Equivalent supplier |                     |
| SOLDER         | Sn:99.3%/Cu:0.7%              | SONGBEN                |                     |
|                |                               | OR Equivalent supplier |                     |



产品承认书  
SPECIFICATION FOR APPROVAL  
注意事项

## Matters needing attention

1、本公司产品适用于 AV 设备、OA 设备、家电、信息服务等一般电子设备中。

Our products are designed and promoted for use in general electronic devices such as audio-video equipment, office automation equipment, home appliance and information service.

2、当本公司的产品使用在一般电子设备以外的领域时，对于此所引发的设备失效我司将不承担任何法律责任。

In case of using the product for the purpose other than general electronics devices, we shall not be held liable for any dysfunctions in or damage to the equipment with which the product is used.

3、本承认书只保证我司产品作为一个单体时的质量情况，当我司产品被安装到贵公司产品上时，请贵司对使用在贵司电路上的产品情况进行了有效评价和确认。

Our specification limits the quality of the component as a single unit. Please ensure the component is thoroughly evaluated in your application circuit.

4、不要对产品施加过大的振动或机械冲击；

Do not apply excessive vibration or mechanical shock to products.

5、为防止断线，请不要使用锋利的物体接触线圈，如镊子；

Do not touch wire with sharp objects such as tweezers to prevent wire breakage.

6、在产品贴装时不要使用过大的压力，避免磁芯断裂。

Do not apply excessive stress to products mounted on boards to prevent core breakage.

7、为保证端子电极的焊接特性和包装材料处于良好状态，请于本公司发货后 6 个月内使用本产品。同时，由于端子电极的焊接特性会随时间发生变化，如果贮存时间超过 6 个月，请首先确认其焊接特性后再安装使用。

To maintain the solderability of terminal electrodes and to keep the packing material in good condition, product should be used within 6 months from the time of delivery. And the solderability of products electrodes may decrease as time passes, so in case of storage over 6 months, solderability shall be checked before actual usage.

8、存放货物的仓库应满足以下条件 Store products in a warehouse in compliance with the following condition:

| 条件 Conditions  | 元件含包装物 Packing status | 元件自身 Component itself |
|----------------|-----------------------|-----------------------|
| 温度 Temperature | -25~+40°C             | -25~+85°C             |
| 湿度 Humidity    | 30~70%RH              | 30~70%RH              |

9、不要使产品遭受温度和湿度的快速变化。

Do not subject products to rapid changes in temperature and humidity.

10、不要将产品存放在化学环境中，如硫酸气体或碱性气体中，否则会降低电极端子的焊接特性和使电感器腐蚀。

Do not store the products in chemical atmosphere such as one containing sulfurous acid gas or alkaline gas, that will causes poor solderability and corrosion of inductors.

11、为了避免受潮气、灰尘等物质的影响，产品应保管于货架上。

Store products on pallets to protect from humidity, dust, etc

12、产品应避免热冲击、振动以及直接光照等等。

Avoid heat shock, vibration, direct sunlight, etc.