

9ZEE01PS
(DRAWING NO.) 台要図

版数 REV.	年月日 DATE	DCN NO.	変更内容 DESCRIPTION	製図 DR.	担当 CHK.	査閲 APPD.	承認 APPD.

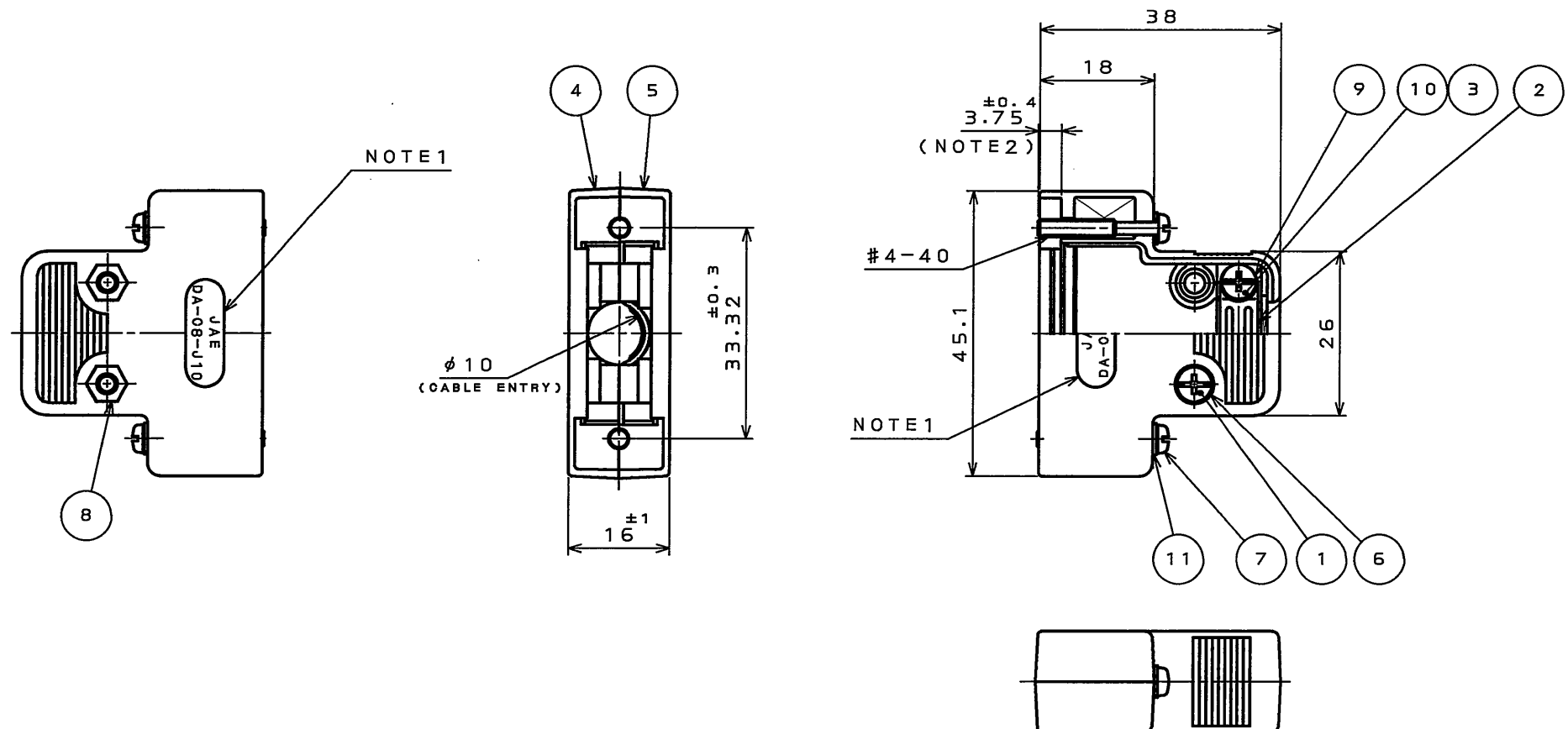

NOTE1. JAE AND PART NUMBER ARE MARKED IN RELIEF AS SHOWN.
(EXCLUDING "-F2-1R" AT THE END OF P/N)
2. THIS DIMENSION REPRESENTS HOWMUCH THE SCREW PROTRUDES.

注1. 図示の位置に社標及び品名を表示する。
但し「-F2-1R」は表示されない。
2. この寸法はねじの出張り量を表す。

符号 NO.	名称 DESCRIPTION	個数 QTY.	材料 MATERIAL	仕上 FINISH	備考 REMARKS
11	FLAT WASHER	2	STEEL	NICKEL PLATED	M2.6
10	SCREW (SLOTTED AND CROSS RECESSED HEAD)	2	STEEL	NICKEL PLATED	M3X6
9	LOCK WASHER	2	STEEL	NICKEL PLATED	M3
8	HEXNUT	2	STEEL	NICKEL PLATED	M3
7	LOCKING SCREW	2	STEEL	NICKEL PLATED	SLOTTED AND CROSS RECESSED HEAD
6	FLAT WASHER	2	STEEL	NICKEL PLATED	M3
5	HOOD B	1	ABS	NICKEL PLATED	UL94V-0
4	HOOD A	1	ABS	NICKEL PLATED	UL94V-0
3	INSERT	2	COPPER ALLOY	NICKEL PLATED	—
2	CLAMP SADDLE	1	STEEL	NICKEL PLATED	—
1	SCREW (SLOTTED AND CROSS RECESSED HEAD)	2	STEEL	NICKEL PLATED	M3X12

仕様書 (SPECIFICATION)	第1版 (ORIGINAL DATE) 13.Jul.2005	尺度 (SCALE) 1:1	シリーズ (SERIES) D-sub	日本航空電子工業株式会社 JAPAN AVIATION ELECTRONICS INDUSTRY, LTD.
製図 DR.	担当 CHK. Y.TAKAGI	名称 (TITLE) DA-C8-J10-F2-1R		
公差 (GENERAL TOLERANCE)	査閲 APPD.	承認 APPD. <i>J. Kubota</i>		図面番号 (DRAWING NO.) SJ103376
寸法 (DIMENSION)	角度 (ANGLES)	質量 (MASS)		
. ±0.5	X° ±			版数 (REV.) 1
.X ±0.5	X°X ±			
.XX ±				
.XXX ±				

DOF-0-212E(03.08)

