

Features

- Low conduction and reverse losses
- Negligible switching losses
- Low forward and reverse recovery times
- Extremely fast switching
- Surface mount device
- Low capacitance diode
- ECOPACK[®]2 compliant component

Description

The BAT54 series uses 40 V Schottky barrier diodes packaged in SO123, SOD323, SOD523, SOT-23, or SOT-323.

Table 1. Device summary

Symbol	Value
I_F	300 mA
V_{RRM}	40 V
C (typ)	7 pF
T_j (max)	150 °C

1 Characteristics

Table 2. Absolute ratings (limiting values at $T_j = 25\text{ °C}$, unless otherwise specified)

Symbol	Parameter	Value	Unit
V_{RRM}	Repetitive peak reverse voltage	40	V
I_F	Continuous forward current	300	mA
I_{FSM}	Surge non repetitive forward current	$t_p = 10\text{ ms}$ Sinusoidal	A
T_{stg}	Storage temperature range	-65 to +150	°C
T_j	Operating junction temperature range	-40 to +150	°C
T_L	Maximum soldering temperature	260	°C

Table 3. Thermal parameters

Symbol	Parameter	Value	Unit
$R_{th(j-a)}$	Junction to ambient ⁽¹⁾	SOT-23, SOD-123	500
		SOT-323, SOD323	550
		SOD-523	600
			°C/W

1. Epoxy printed circuit board with recommended pad layout

Table 4. Static electrical characteristics

Symbol	Parameter	Test conditions	Min.	Typ.	Max.	Unit
$I_R^{(1)}$	Reverse leakage current	$T_j = 25\text{ °C}$	$V_R = 30\text{ V}$		1	μA
		$T_j = 100\text{ °C}$			100	
$V_F^{(2)}$	Forward voltage drop	$T_j = 25\text{ °C}$	$I_F = 0.1\text{ mA}$		240	mV
			$I_F = 1\text{ mA}$		320	
			$I_F = 10\text{ mA}$		400	
			$I_F = 30\text{ mA}$		500	
			$I_F = 100\text{ mA}$		900	

1. Pulse test: $t_p = 5\text{ ms}$, $\delta < 2\%$

2. Pulse test: $t_p = 380\text{ }\mu\text{s}$, $\delta < 2\%$

Table 5. Dynamic characteristics

Symbol	Parameter	Test conditions	Min.	Typ.	Max.	Unit
C	Diode capacitance	$V_R = 1\text{ V}$, $F = 1\text{ MHz}$		7	10	pF
t_{rr}	Reverse recovery time	$I_F = 10\text{ mA}$, $I_R = 10\text{ mA}$, $T_j = 25\text{ °C}$ $I_{rr} = 1\text{ mA}$, $R_L = 100\text{ }\Omega$			5	ns

Figure 1. Average forward power dissipation versus average forward current

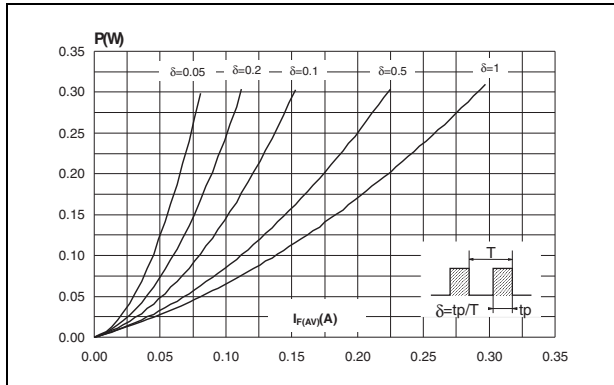

Figure 2. Average forward current versus ambient temperature ($\delta = 1$)

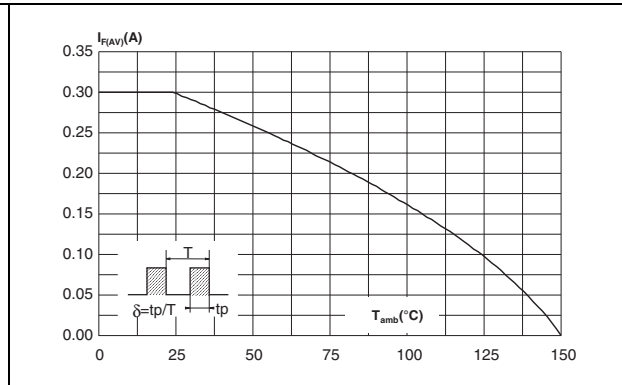

Figure 3. Reverse leakage current versus reverse applied voltage (typical values)

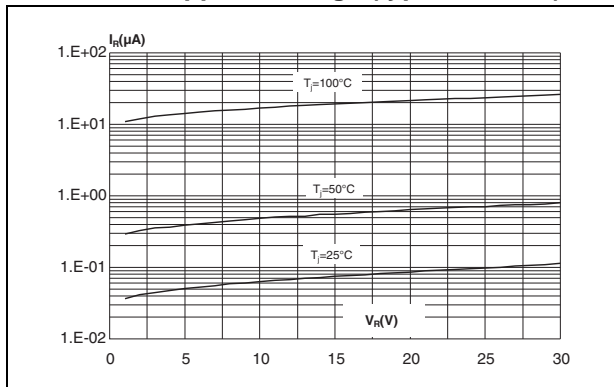

Figure 4. Reverse leakage current versus junction temperature

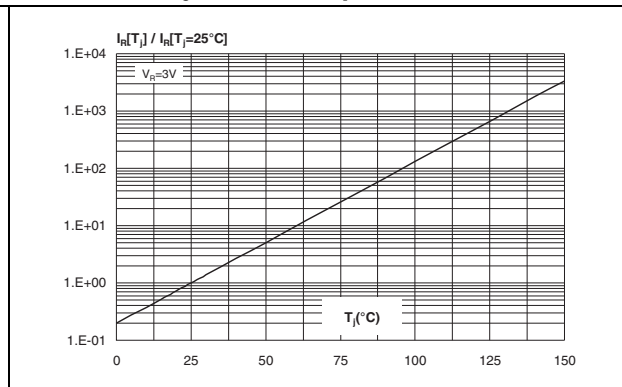

Figure 5. Junction capacitance versus reverse applied voltage (typical values)

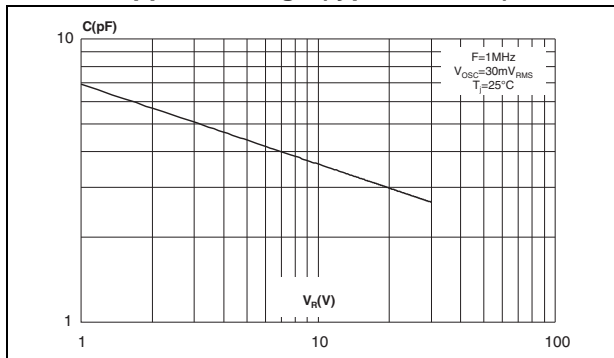

Figure 6. Forward voltage drop versus forward current (typical values)

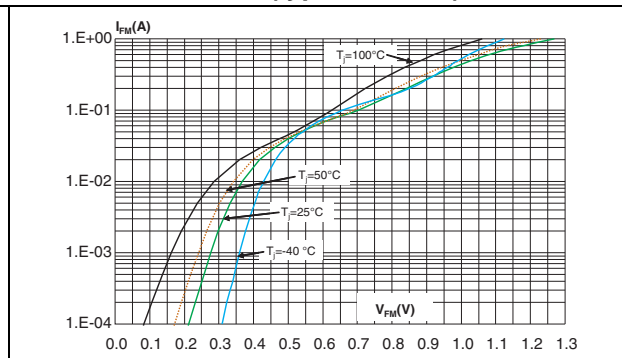

Figure 7. Thermal resistance junction to ambient versus copper surface under each lead (SOD323)

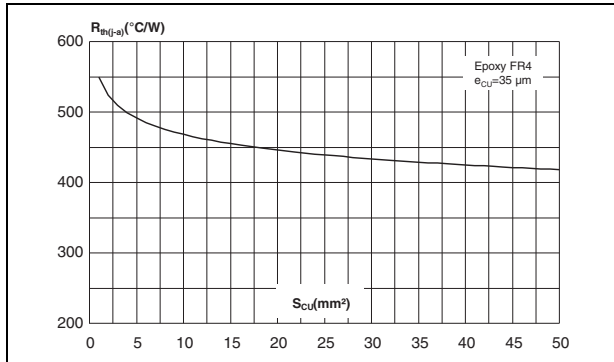

Figure 8. Relative variation of thermal impedance junction to ambient versus pulse duration (SOD323)

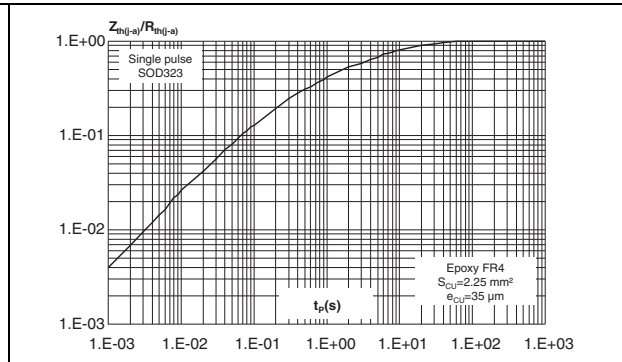

Figure 9. Relative variation of thermal impedance junction to ambient versus pulse duration (SOT23)

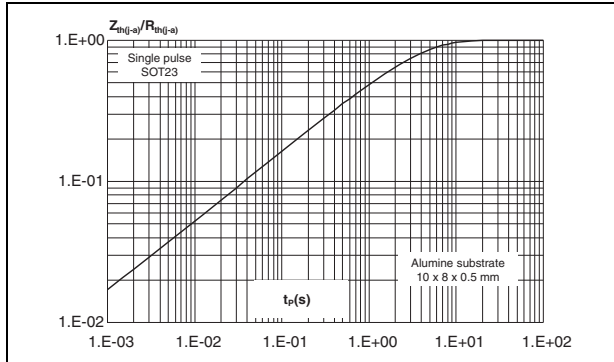
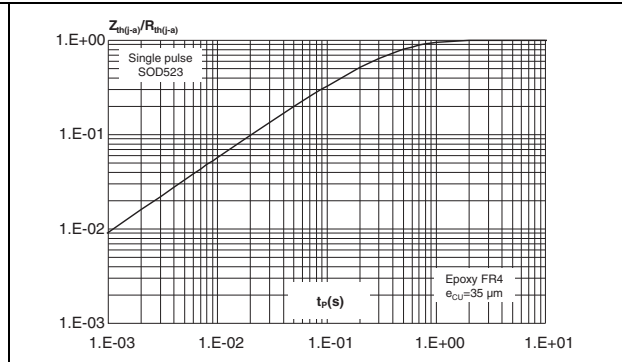

Figure 10. Relative variation of thermal impedance junction to ambient versus pulse duration (SOD-523)



2 Package information

Figure 11. SOD123 dimension definitions

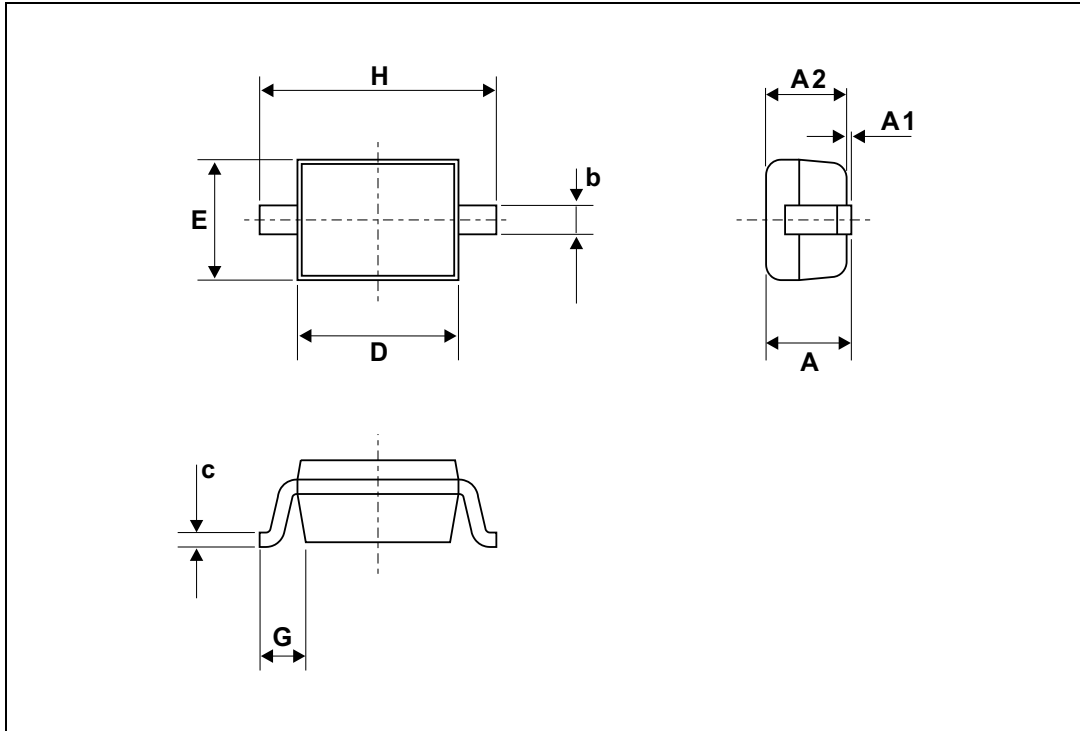

Table 6. SOD123 dimension values

Ref.	Dimensions					
	Millimeters			Inches		
	Min.	Typ.	Max.	Min.	Typ.	Max.
A			1.45			0.057
A1	0		0.10		0	0.004
A2	0.85		1.35	0.033		0.053
b		0.55			0.022	
c		0.15			0.039	
D	2.55		2.85	0.1		0.112
E	1.4		1.70	0.055		0.067
G	0.25			0.01		
H	3.55		3.75	0.14		0.148

Figure 12. SOD123 footprint dimensions in mm (inches)

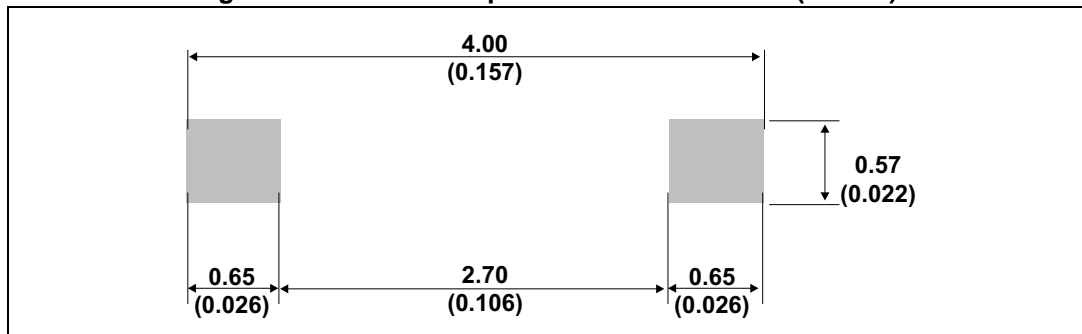

Figure 13. SOD323 dimension definitions

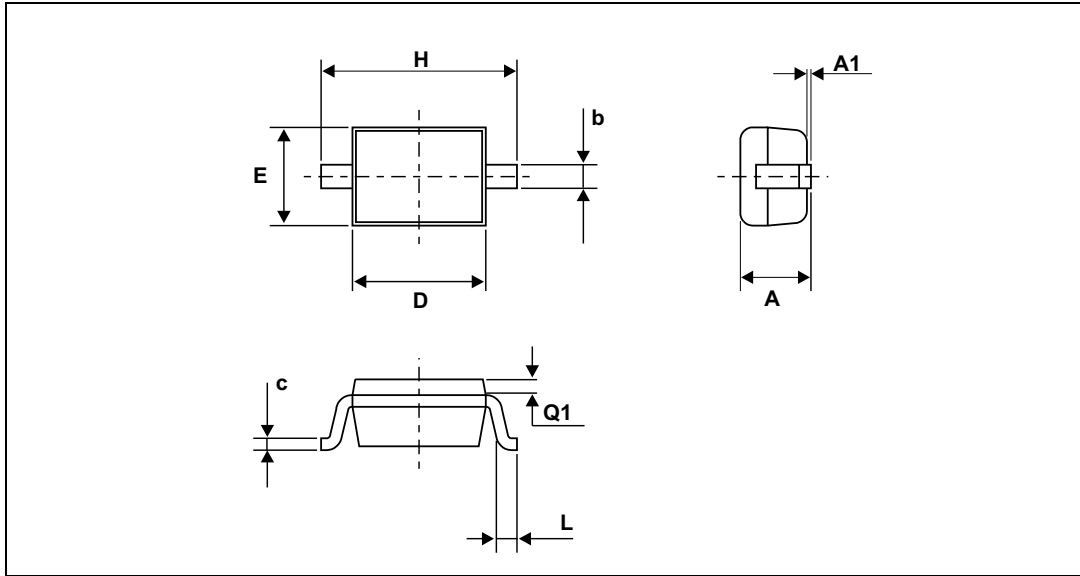

Table 7. SOD323 dimension values

Ref.	Dimensions					
	Millimeters			Inches		
	Min.	Typ.	Max.	Min.	Typ.	Max.
A			1.17			0.046
A1	0		0.1	0		0.004
b	0.25		0.44	0.01		0.017
c	0.1		0.25	0.004		0.01
D	1.52		1.8	0.06		0.071
E	1.11		1.45	0.044		0.057
H	2.3		2.7	0.09		0.106
L	0.1		0.46	0.004		0.02
Q1	0.1		0.41	0.004		0.016

Figure 14. SOD323 footprint dimensions in mm (inches)

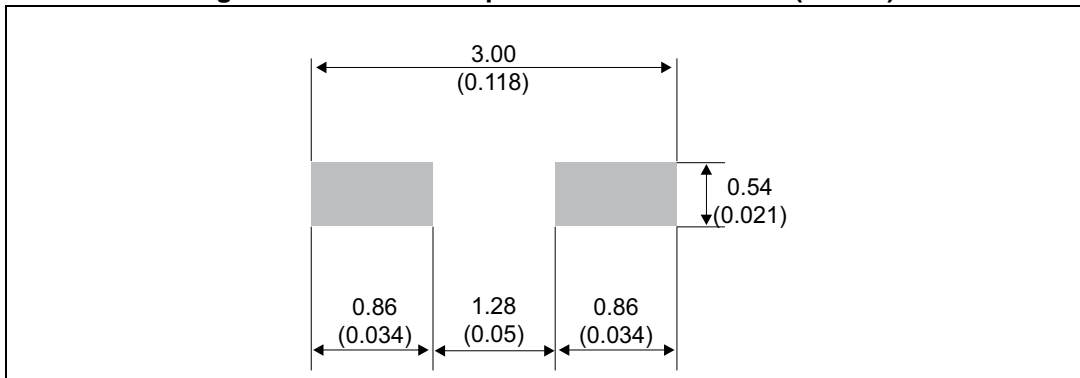

Figure 15. SOD-523 dimension definitions

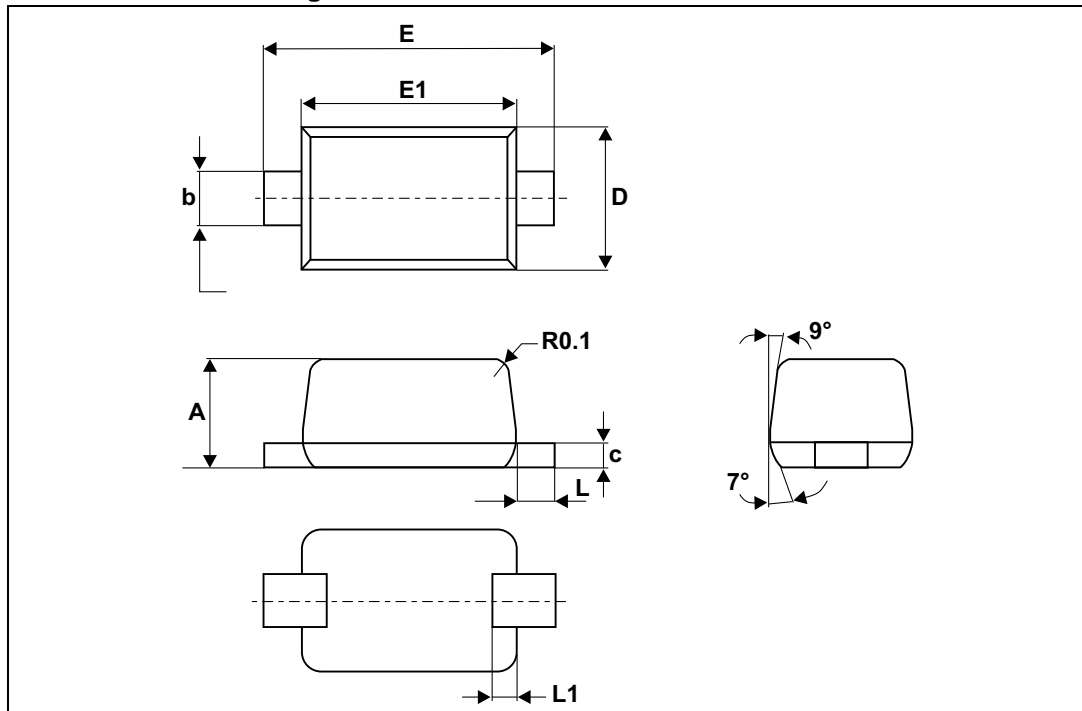

Table 8. SOD-523 dimension values

Ref.	Dimensions					
	Millimeters			Inches		
	Min.	Typ.	Max.	Min.	Typ.	Max.
A	0.50	0.60	0.70	0.020	0.024	0.028
E	1.50	1.60	1.70	0.059	0.063	0.067
E1	1.10	1.20	1.30	0.043	0.047	0.051
D	0.70	0.80	0.90	0.028	0.031	0.035
b	0.25		0.35	0.010		0.014
c	0.07		0.20	0.003		0.008
L	0.15	0.20	0.25	0.006	0.008	0.010
L1	0.05		0.20	0.002		0.008

Figure 16. SOD-523 footprint dimensions in mm (inches)

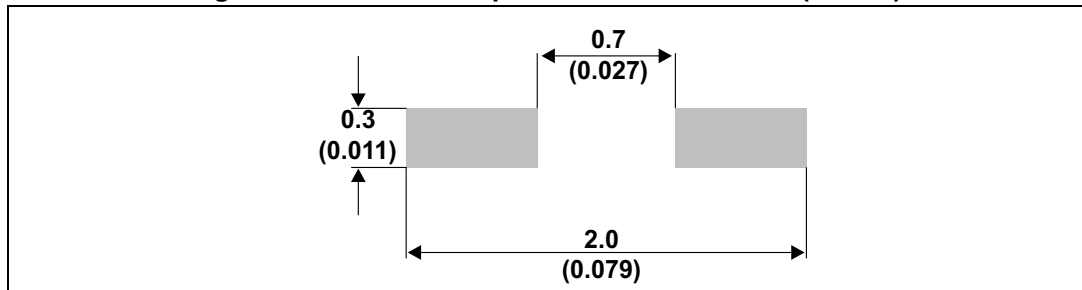

Figure 17. SOT23 dimension definitions

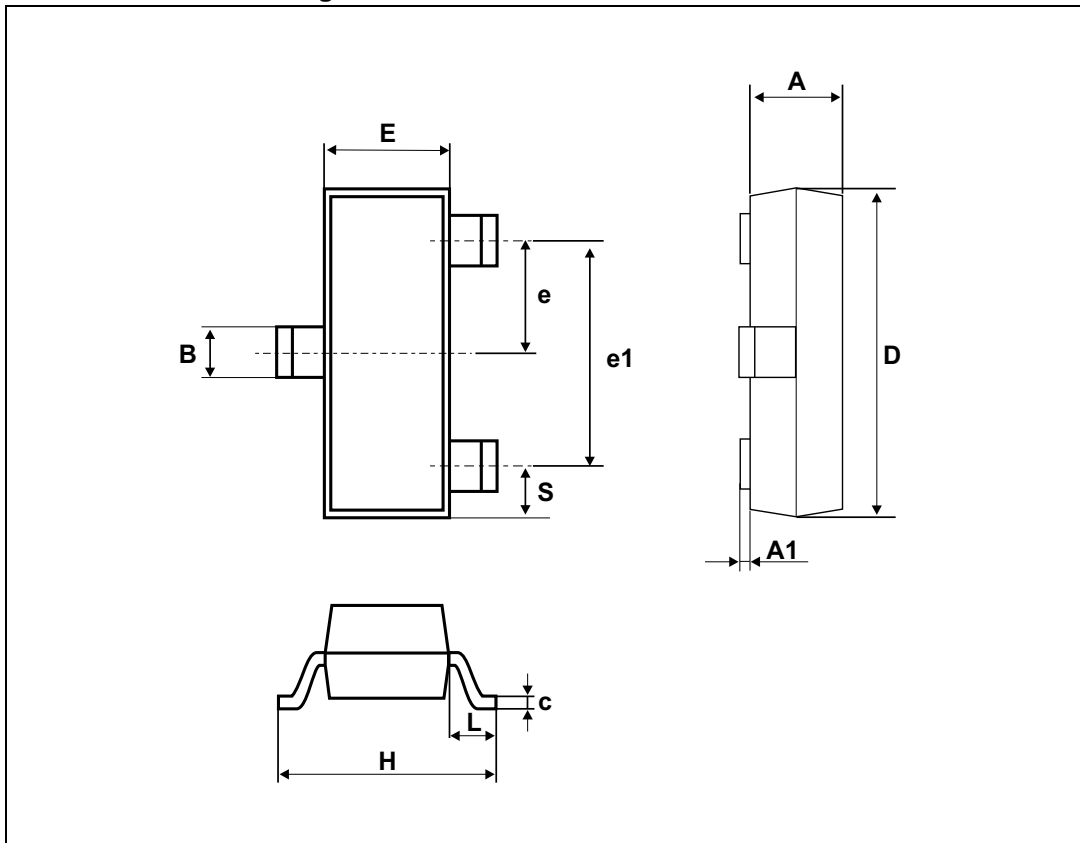

Table 9. SOT23 dimension values

Ref.	Dimensions					
	Millimeters			Inches		
	Min.	Typ.	Max.	Min.	Typ.	Max.
A	0.89		1.4	0.035		0.055
A1	0		0.1	0		0.004
B	0.3		0.51	0.012		0.02
c	0.085		0.18	0.003		0.007
D	2.75		3.04	0.108		0.12
e	0.85		1.05	0.033		0.041
e1	1.7		2.1	0.067		0.083
E	1.2		1.75	0.047		0.069
H	2.1		3.00	0.083		0.118
L		0.6			0.024	
S	0.35		0.65	0.014		0.026

Figure 18. SOT23 footprint dimensions in mm (inches)

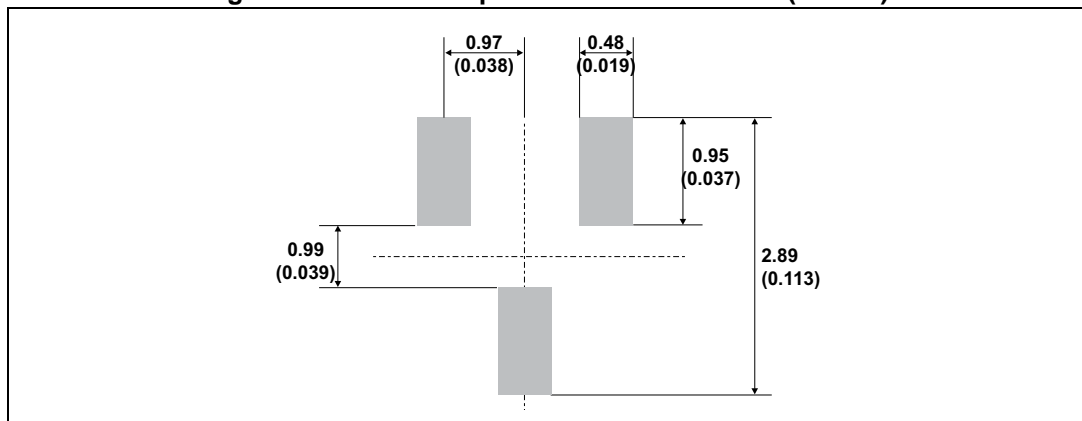

Figure 19. SOT-323 dimension definitions

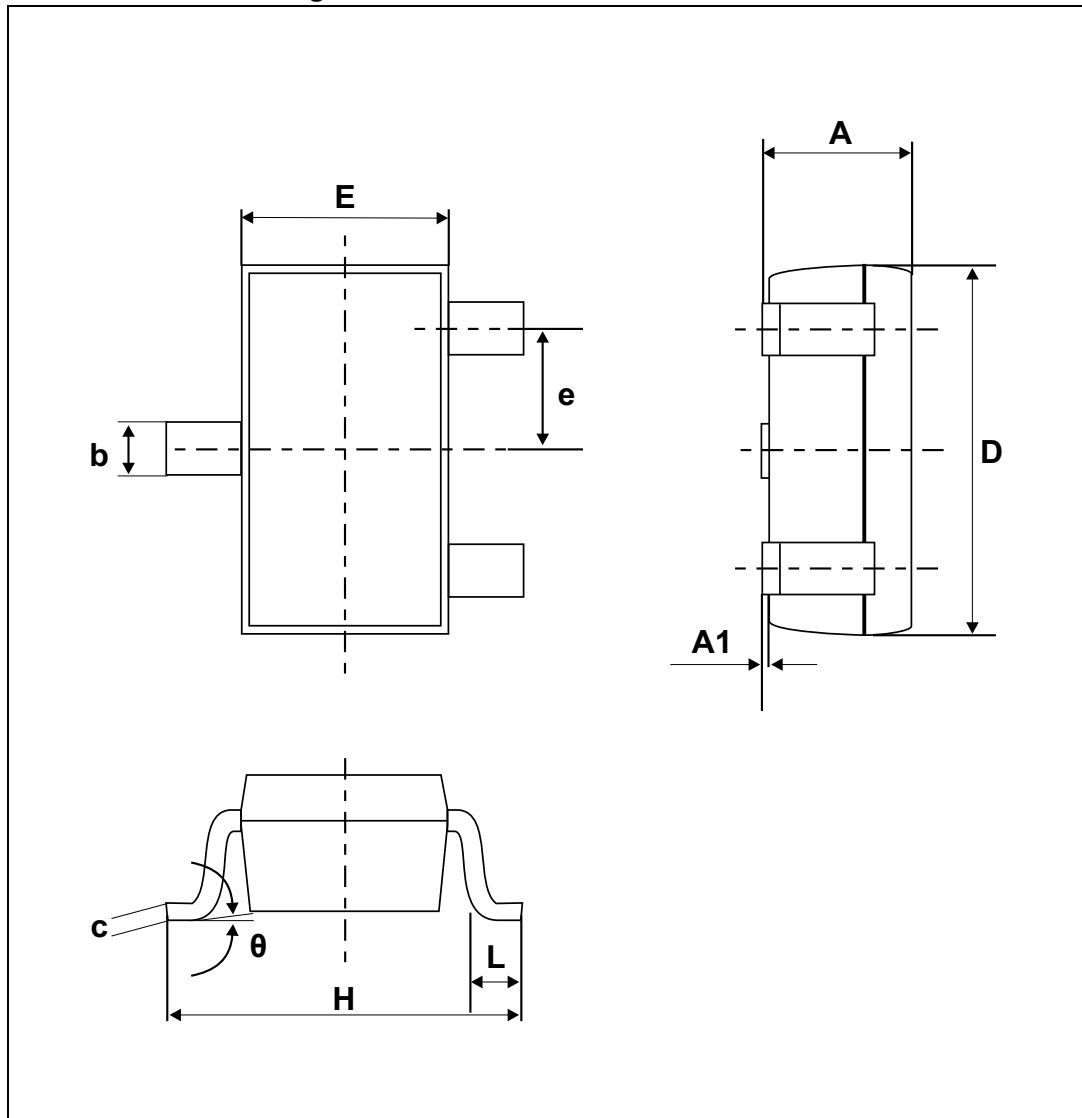
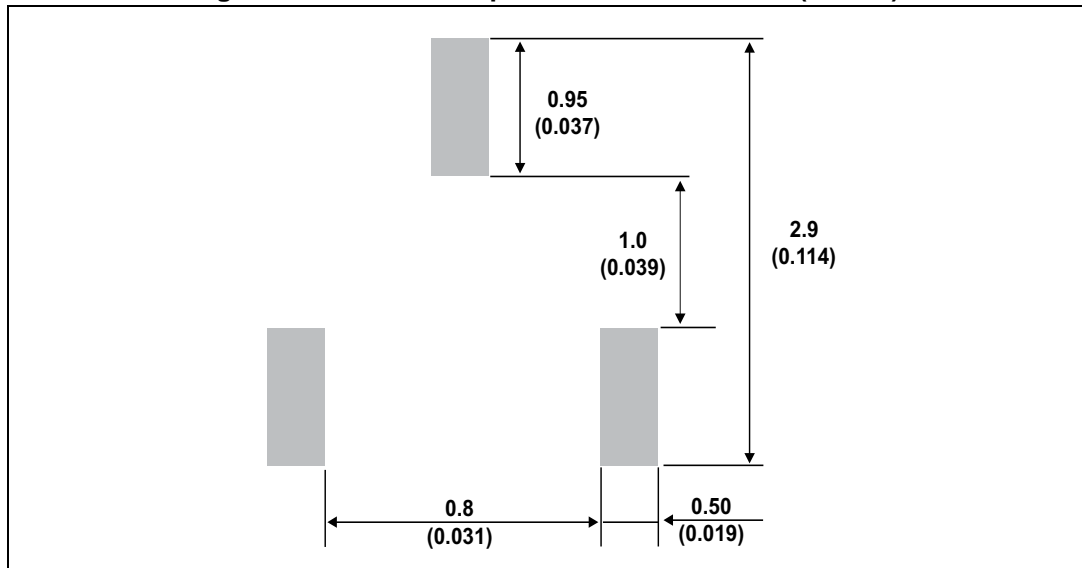

Table 10. SOT-323 dimension values

Ref.	Dimensions					
	Millimeters			Inches		
	Min.	Typ.	Max.	Min.	Typ.	Max.
A	0.8		1.1	0.031		0.043
A1	0.0		0.1	0.0		0.004
b	0.25		0.4	0.010		0.016
c	0.1		0.26	0.004		0.010
D	1.8	2.0	2.2	0.071	0.079	0.086
E	1.15	1.25	1.35	0.045	0.049	0.053
e	0.6	0.65	0.7	0.023	0.026	0.027
H	1.8	2.1	2.4	0.071	0.083	0.094
L	0.1	0.2	0.3	0.004	0.008	0.012
q	0		30°	0		30°

Figure 20. SOT-323 footprint dimensions in mm (inches)



3 Ordering information

Figure 21. Ordering information scheme

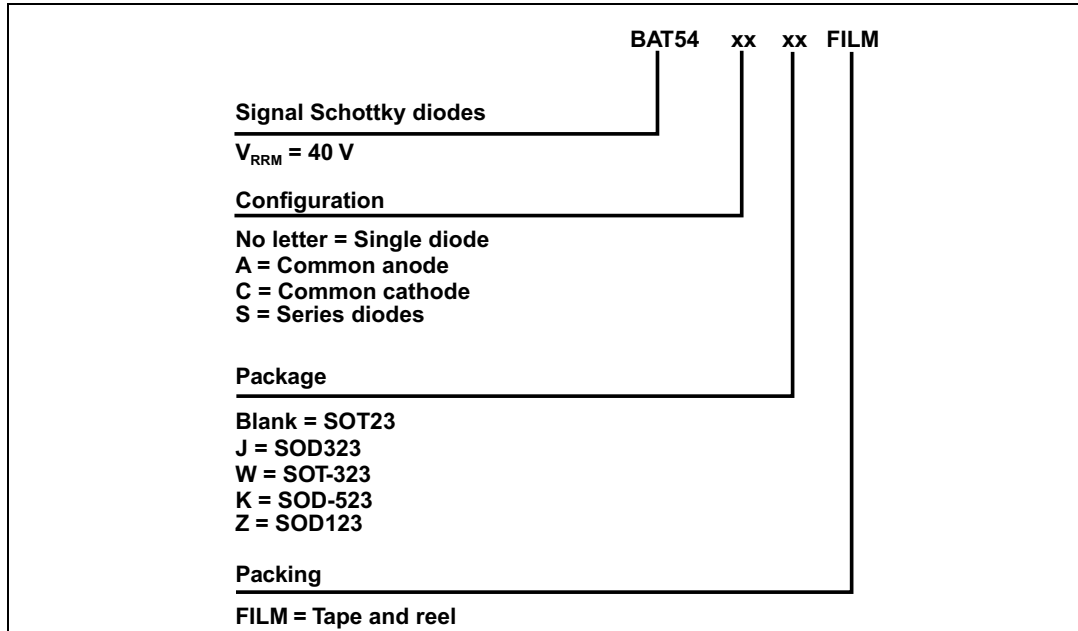

Table 11. Ordering information

Order code	Marking	Package	Weight	Base qty	Delivery mode
BAT54FILM	D86	SOT-23 Single	10 mg	3000	Tape and reel
BAT54SFILM	D88	SOT-23 Serial	10 mg	3000	Tape and reel
BAT54CFILM	KL3	SOT-23 Common cathode	10 mg	3000	Tape and reel
BAT54AFILM	D84	SOT-23 Common anode	10 mg	3000	Tape and reel
BAT54WFILM	D73	SOT-323 Single	6 mg	3000	Tape and reel
BAT54SWFILM	D78	SOT-323 Serial	6 mg	3000	Tape and reel
BAT54CWFILM	D77	SOT-323 Common cathode	6 mg	3000	Tape and reel
BAT54AWFILM	D74	SOT-323 Common anode	6 mg	3000	Tape and reel
BAT54JFILM	86	SOD-323	5 mg	3000	Tape and reel
BAT54JFILM-HQ	86	SOD-323	5 mg	10000	Tape and reel
BAT54KFILM	86	SOD-523	1.4 mg	3000	Tape and reel
BAT54ZFILM	D72	SOD-123	10 mg	3000	Tape and reel