

RECOMMENDED P.C.B. LAYOUT
TOLERANCE UNSPECIFIED ±0.05mm

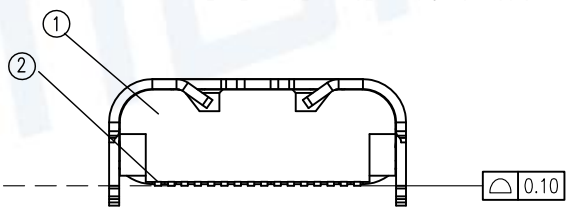
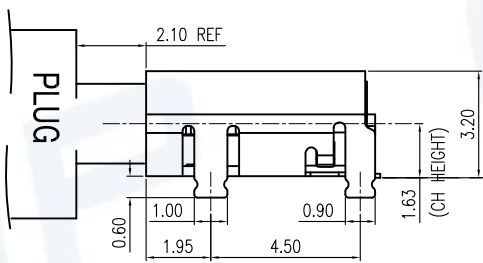
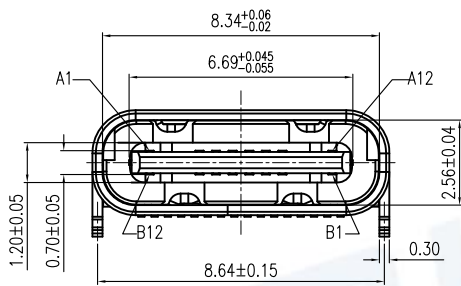

REV.	DESCRIPTION OF REVISIONS	APPR.	CHKD.	DRAW.	DATE
△	Original reversion	lucky	lucky	Roy	2019.8.10
△	All product model	lucky	lucky	Roy	2020.03.19
△	Delete Model No. U20405-2	lucky	lucky	Roy	2020.10.12

NOTE:
 1. MECHANICAL:
 1-1 Insertion force: 5~20N
 1-2 Extraction force: 8~20N
 Extraction force: 10000 CYCLES 6~20N
 1-3. FREQUENCY: 500±50 CYCLES/HOUR, 10000 CYCLES;
 2. ELECTRICAL CHARACTERISTICS:
 2-1. CURRENT RATING:
 VBUS Pins (A4,A9,B4,B9): 5.0A.
 Vconn(B5) : 1.25A
 Other All Pins 0.25A
 2-2. INITIAL CONTACT RESISTANCE: 40mΩ Max.
 2-3. INSULATION RESISTANCE: 100MΩ MIN
 2-4. WITHSTANDING VOLTAGE: 100V AC, 1 MINUTE;
 3. ENVIRONMENTAL
 TEMPERATURE RANGE: -40°C TO +85°C.

Model No.	PLATING
U20405-1	3U"
U20405-3	1U"

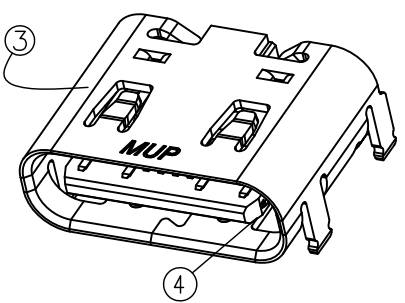
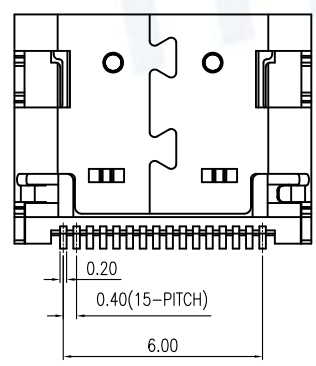

PIN ASSIGNMENT																
PCB No.	C1	C2	C3	C4	C5	C6	C7	C8	C9	C10	C11	C12	C13	C14	C15	C16
PIN No.	B12	A1	B9	A4	A5	A6	A7	A8	B8	B7	B6	B5	B4	A9	B1	A1 ₂
	GND		VBUS		CC1	D+	D-	SBU1	SBU2	D-	D+	CC2	VBUS		GND	
ITEM	PART NAME	Q'TY	MATERIAL				FINISH									
①	Molding	1	THERMOPLASTIC				Black, UL94V-0									
②	CONTACT	1	HIGH CONDUCTIVITY COPPER				Contact area: Gold plated over Ni.									
③	SHELL	1	STAINLESS STEEL				Ni plated over all									
④	MID-PLATE	1	STAINLESS STEEL				Cleaning									

Unless Otherwise specified, other tolerance are:

MUP MUP INDUSTRIAL CO.,LTD.

NAME: **USB Type C SINGLE-Row SMT Receptacle**

MODEL No: **MUP-U20405-X**

TYPE : **16Pin & Without Post on board L=6.90**

APPR.	LUCKY/2020.10.12	PRAT NO.:	U20405-X	DWG NO.:	DWG-U20405-X-001
CHKD.	LUCKY/2020.10.12	PROJ.	UNIT	SCALE	SHEET
DRAW.	Roy/2020.10.12	PROJ.	mm	1:1	1/1
					REVISION
					3



REV.	DESCRIPTION OF REVISIONS	APPR.	CHKD.	DRAW.	DATE
△	Original reversion	lucky	lucky	Roy	2019.8.10
△	Add product model	lucky	lucky	Roy	2020.03.19
△	Delete Model No. U20405-2	lucky	lucky	Roy	2020.10.12

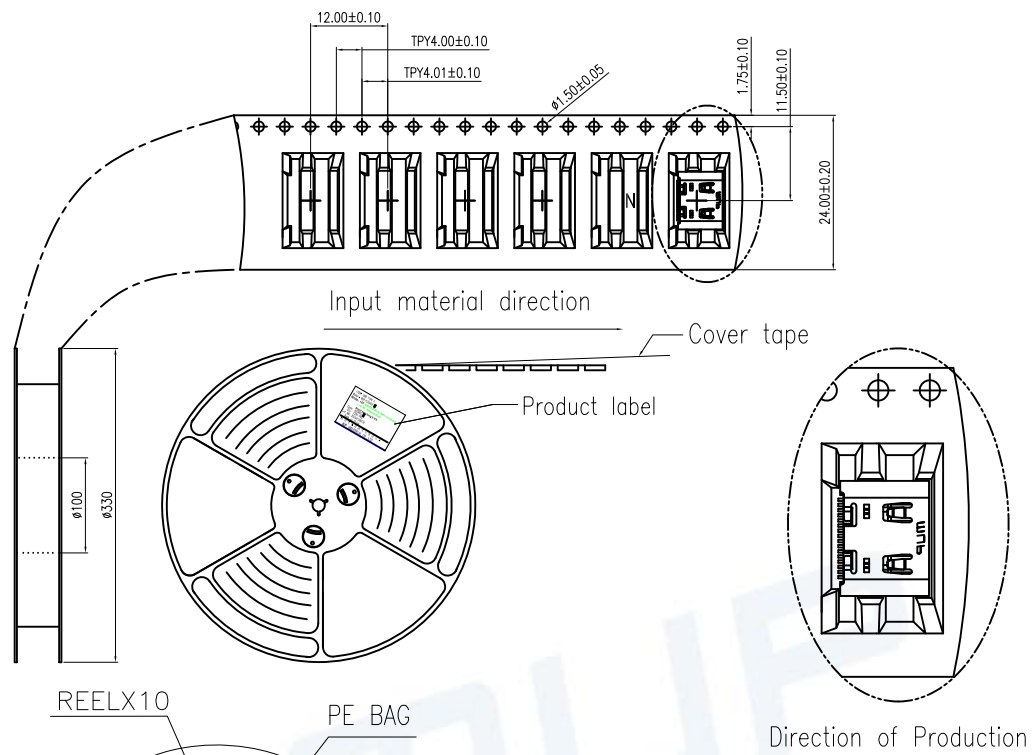

NOTES

1. NUMBER OF CONNECTORS: 1200PCS/REEL
2. LEAD TAPE LENGTH

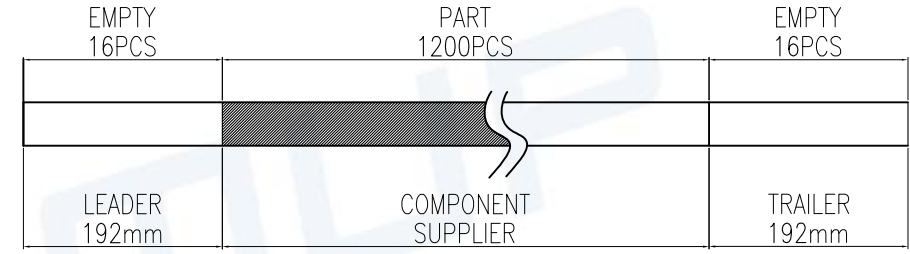

3. QUANTITY: 12000/CARTON
4. WEIGHT :
 - 4.1 NET WEIGHT : 5.0 Kg
 - 4.2 GROSS WEIGHT : 10.3 Kg

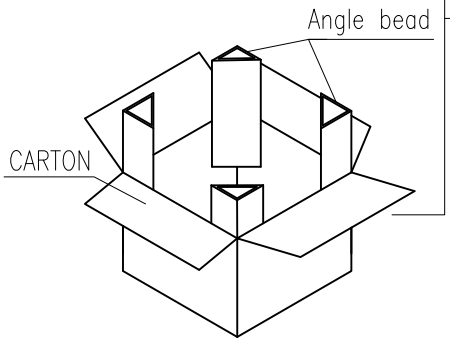
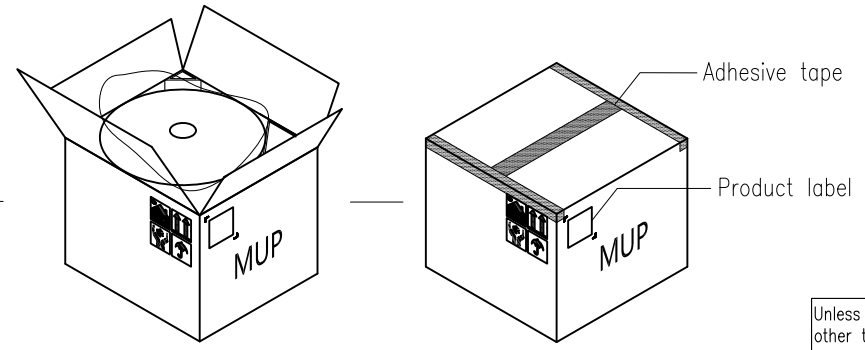
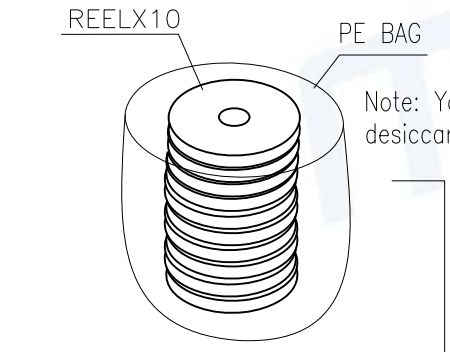

Unless Otherwise specified, other tolerance are:

X. ±0.40	X'. ±5°
X.X ±0.30	X.X' ±4°
X.XX ±0.25	X.XX' ±3°
X.XXX±0.15	X.XXX'±2°

APPR.	LUCKY/2020.10.12
CHKD.	LUCKY/2020.10.12
DRAW.	Roy/2020.10.12

MUP MUP INDUSTRIAL CO.,LTD.	
NAME: USB Type C SINGLE-Row SMT Receptacle	
MODEL No: MUP-U20405-X	
TYPE : 16Pin & Without Post on board L=6.90	
PROJ.	UNIT mm
SCALE 1:1	SHEET 2/2
REVISION 3	

