

# Zero-Drift, Rail-to-Rail I/O CMOS Operational Amplifiers

## FEATURES

- **Low Offset Voltage:  $\pm 20\mu\text{V}$  (MAX)**
- **Input Offset Drift:  $\pm 0.1\mu\text{V}/^\circ\text{C}$  (TYP)**
- **High Gain Bandwidth Product: 11MHz**
- **Rail-to-Rail Input and Output**
- **High Gain, CMRR, PSRR: 120dB(TYP)**
- **High Slew Rate: 8.5V/us**
- **Low Noise: 0.48uVp-p (0.01Hz~10Hz)**
- **Low Power Consumption: 1.3mA /op amp**
- **Overload Recovery Time: 0.4us**
- **Low Supply Voltage: +2.9 V to +5.5 V**
- **No External Capacitors Required**
- **Extended Temperature:  $-40^\circ\text{C}$  to  $+125^\circ\text{C}$**

## APPLICATIONS

- **Temperature Sensors**
- **Medical/Industrial Instrumentation**
- **Pressure Sensors**
- **Battery-Powered Instrumentation**
- **Active Filtering**
- **Weight Scale Sensor**
- **Strain Gage Amplifiers**
- **Power Converter/Inverter**

## DESCRIPTION

The RS8561, RS8562, RS8564, RS8563 (dual version & shutdown) series of CMOS operational amplifiers use auto-zero techniques to simultaneously provide very low offset voltage (20uV max) and near-zero drift over time and temperature. This family of amplifiers has ultralow noise, offset and power.

This miniature, high-precision operational amplifiers offset high input impedance and rail-to-rail input and rail-to-rail output swing. With high gain-bandwidth product of 11MHz and slew rate of 8.5V/us.

Single or dual supplies as low as +2.9V ( $\pm 1.45\text{V}$ ) and up to +5.5V ( $\pm 2.75\text{V}$ ) may be used.

The RS8561/RS8562/RS8564/RS8563 (dual version with shutdown) are specified for the extended industrial and automotive temperature range ( $-40^\circ\text{C}$  to  $125^\circ\text{C}$ ). The RS8561 single amplifier is available in 5-lead SOT23, 8-lead MSOP8 and 8-lead SOIC packages, The RS8562 dual amplifier is available in 8-lead SOIC and 8-lead MSOP narrow surface mount packages, The RS8563 (dual version with shutdown) comes in Micro-SIZE MSOP-10. The RS8564 quad is available in 14-lead SOIC and 14-lead narrow TSSOP packages.

## Device Information (1)

PART NUMBER	PACKAGE	BODY SIZE (NOM)
RS8561	SOT23-5	2.90mmx1.60mm
	SOIC-8 (SOP8)	4.90mmx3.90mm
	MSOP-8	3.00mmx3.00mm
RS8562	SOIC-8 (SOP8)	4.90mmx3.90mm
	MSOP-8	3.00mmx3.00mm
RS8563	MSOP-10	3.00mmx3.00mm
RS8564	SOIC-14 (SOP14)	8.65mmx3.90mm
	TSSOP-14	5.00mmx4.40mm

(1) For all available packages, see the orderable addendum at the end of the data sheet.

## Revision History

Note: Page numbers for previous revisions may differ from page numbers in the current version.

Version	Change Date	Change Item
C.1	2022/05/17	1. Update Package Qty on Page 3@RevB.6 2. Added TAPE AND REEL INFORMATION 3. Added APPLICATION NOTE

## Pin Configuration and Functions (Top View)

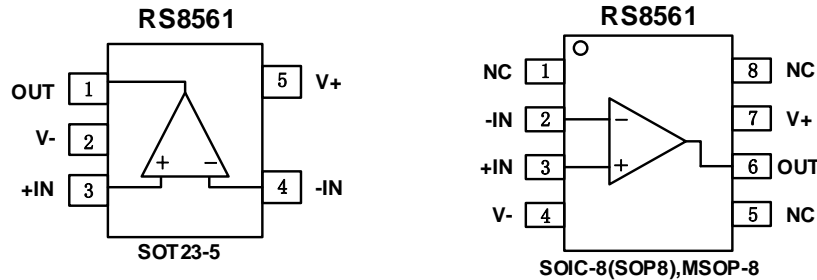

### Pin Description

NAME	PIN		I/O	DESCRIPTION
	RS8561	RS8561		
	SOT23-5	SOIC-8 (SOP8)/ MSOP8		
-IN	4	2	I	Negative (inverting) input
+IN	3	3	I	Positive (noninverting) input
NC	-	1,5,8	-	No internal connection (can be left floating)
OUT	1	6	O	Output
V-	2	4	-	Negative (lowest) power supply
V+	5	7	-	Positive (highest) power supply

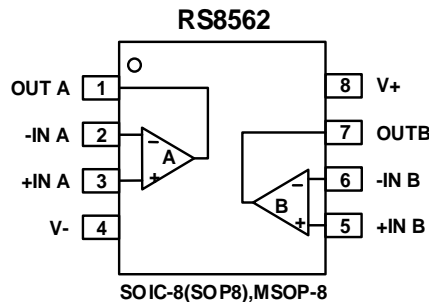

### Pin Description

NAME	PIN		I/O	DESCRIPTION
	SOIC-8 (SOP8)/ MSOP8			
-INA	2	I	Inverting input, channel A	
+INA	3	I	Noninverting input, channel A	
-INB	6	I	Inverting input, channel B	
+INB	5	I	Noninverting input, channel B	
OUTA	1	O	Output, channel A	
OUTB	7	O	Output, channel B	
V-	4	-	Negative (lowest) power supply	
V+	8	-	Positive (highest) power supply	

## Pin Configuration and Functions (Top View)

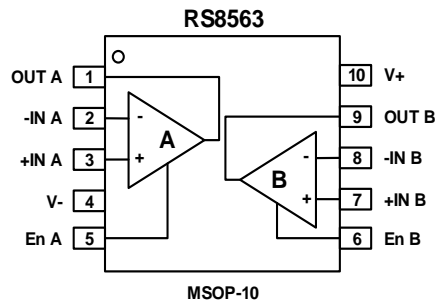

## Pin Description

NAME	PIN	I/O	DESCRIPTION
	MSOP-10		
-INA	2	I	Inverting input, channel A
+INA	3	I	Noninverting input, channel A
-INB	8	I	Inverting input, channel B
+INB	7	I	Noninverting input, channel B
EnA	5	I	Enable Input. A logic low reduces the supply current to 10nA. Connect to IN for normal operation, channel A
EnB	6	I	Enable Input. A logic low reduces the supply current to 10nA. Connect to IN for normal operation, channel B
OUTA	1	O	Output, channel A
OUTB	9	O	Output, channel B
V-	4	-	Negative (lowest) power supply
V+	10	-	Positive (highest) power supply

## Pin Configuration and Functions (Top View)

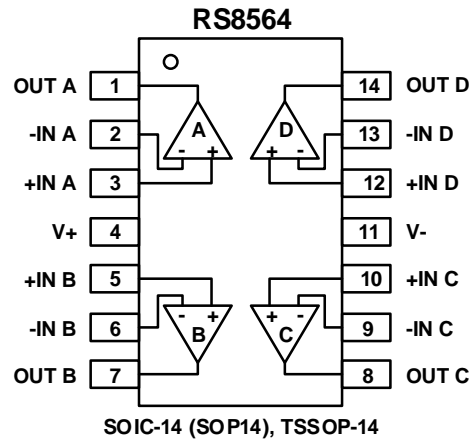

### Pin Description

NAME	PIN	I/O	DESCRIPTION
	SOIC-14 (SOP14)/ TSSOP-14		
-INA	2	I	Inverting input, channel A
+INA	3	I	Noninverting input, channel A
-INB	6	I	Inverting input, channel B
+INB	5	I	Noninverting input, channel B
-INC	9	I	Inverting input, channel C
+INC	10	I	Noninverting input, channel C
-IND	13	I	Inverting input, channel D
+IND	12	I	Noninverting input, channel D
OUTA	1	O	Output, channel A
OUTB	7	O	Output, channel B
OUTC	8	O	Output, channel C
OUTD	14	O	Output, channel D
V-	11	-	Negative (lowest) power supply
V+	4	-	Positive (highest) power supply

## SPECIFICATIONS

### Absolute Maximum Ratings

Over operating free-air temperature range (unless otherwise noted) <sup>(1)</sup>

		MIN	MAX	UNIT
Voltage	Supply, $V_S=(V+) - (V-)$		7.0	V
	Signal input pin <sup>(2)</sup>	(V-) -0.5	(V+) +0.5	
	Signal output pin <sup>(3)</sup>	(V-) -0.5	(V+) +0.5	
Current	Signal input pin <sup>(2)</sup>	-10	10	mA
	Signal output pin <sup>(3)</sup>	-55	55	mA
	Output short-circuit <sup>(4)</sup>	Continuous		
Temperature	Operating range, $T_A$	-40	125	°C
	Junction, $T_J$	-40	150	
	Storage, $T_{stg}$	-65	150	

- (1) Stresses above these ratings may cause permanent damage. Exposure to absolute maximum conditions for extended periods may degrade device reliability. These are stress ratings only, and functional operation of the device at these or any other conditions beyond those specified is not implied.
- (2) Input terminals are diode-clamped to the power-supply rails. Input signals that can swing more than 0.5V beyond the supply rails should be current-limited to 10mA or less.
- (3) Output terminals are diode-clamped to the power-supply rails. Output signals that can swing more than 0.5V beyond the supply rails should be current-limited to  $\pm 55$ mA or less.
- (4) Short-circuit to ground, one amplifier per package.

### ESD Ratings

			VALUE	UNIT
$V_{(ESD)}$	Electrostatic discharge	Human-body model (HBM)	$\pm 5000$	V
		Machine Model (MM)	$\pm 400$	

### Recommended Operating Conditions

Over operating free-air temperature range (unless otherwise noted)

		MIN	NOM	MAX	UNIT
Supply voltage, $V_S= (V+) - (V-)$	Single-supply	2.9		5.5	V
	Dual-supply	$\pm 1.45$		$\pm 2.75$	

### Thermal Information: RS8561

THERMAL METRIC		RS8561			UNIT
		5PINS	8PINS		
		SOT23-5	SOIC-8	MSOP-8	
$R_{\theta JA}$	Junction-to-ambient thermal resistance	273.8	116	165	°C/W
$R_{\theta JC (top)}$	Junction-to-case (top) thermal resistance	126.8	60	53	°C/W
$R_{\theta JB}$	Junction-to-board thermal resistance	85.9	56	87	°C/W
$\Psi_{JT}$	Junction-to-top characterization parameter	10.9	12.8	4.9	°C/W
$\Psi_{JB}$	Junction-to-board characterization parameter	84.9	98.3	85	°C/W
$R_{\theta JC (bot)}$	Junction-to-case (bottom) thermal resistance	N/A	N/A	N/A	°C/W

**Thermal Information: RS8562**

THERMAL METRIC		RS8562		UNIT
		8PINS		
		SOIC-8	MSOP8	
R <sub>θJA</sub>	Junction-to-ambient thermal resistance	116	165	°C/W
R <sub>θJC (top)</sub>	Junction-to-case (top) thermal resistance	60	53	°C/W
R <sub>θJB</sub>	Junction-to-board thermal resistance	56	87	°C/W
Ψ <sub>JT</sub>	Junction-to-top characterization parameter	12.8	4.9	°C/W
Ψ <sub>JB</sub>	Junction-to-board characterization parameter	98.3	85	°C/W
R <sub>θJC (bot)</sub>	Junction-to-case (bottom) thermal resistance	N/A	N/A	°C/W

**Thermal Information: RS8563**

THERMAL METRIC		RS8563		UNIT
		10PINS		
		MSOP-10		
R <sub>θJA</sub>	Junction-to-ambient thermal resistance	169.5		°C/W
R <sub>θJC (top)</sub>	Junction-to-case (top) thermal resistance	84.1		°C/W
R <sub>θJB</sub>	Junction-to-board thermal resistance	113		°C/W
Ψ <sub>JT</sub>	Junction-to-top characterization parameter	15.8		°C/W
Ψ <sub>JB</sub>	Junction-to-board characterization parameter	111.6		°C/W
R <sub>θJC (bot)</sub>	Junction-to-case (bottom) thermal resistance	N/A		°C/W

**Thermal Information: RS8564**

THERMAL METRIC		RS8564		UNIT
		14PINS		
		SOIC-14	TSSOP-14	
R <sub>θJA</sub>	Junction-to-ambient thermal resistance	83.8	120.8	°C/W
R <sub>θJC (top)</sub>	Junction-to-case (top) thermal resistance	70.7	34.3	°C/W
R <sub>θJB</sub>	Junction-to-board thermal resistance	59.5	62.8	°C/W
Ψ <sub>JT</sub>	Junction-to-top characterization parameter	11.6	1	°C/W
Ψ <sub>JB</sub>	Junction-to-board characterization parameter	37.7	56.5	°C/W
R <sub>θJC (bot)</sub>	Junction-to-case (bottom) thermal resistance	N/A	N/A	°C/W

**PACKAGE/ORDERING INFORMATION**

Orderable Device	Package Type	Pin	Channel	Op Temp(°C)	Device Marking <sup>(1)</sup>	Package Qty
RS8561XF	SOT23-5	5	1	-40°C ~125°C	8561	Tape and Reel,3000
RS8561XK	SOIC-8 (SOP8)	8	1	-40°C ~125°C	RS8561	Tape and Reel,4000
RS8561XM	MSOP-8	8	1	-40°C ~125°C	RS8561	Tape and Reel,4000
RS8562XK	SOIC-8 (SOP8)	8	2	-40°C ~125°C	RS8562	Tape and Reel,4000
RS8562XM	MSOP-8	8	2	-40°C ~125°C	RS8562	Tape and Reel,4000
RS8563XN	MSOP-10	10	2	-40°C ~125°C	RS8563	Tape and Reel,4000
RS8564XP	SOIC-14 (SOP14)	14	4	-40°C ~125°C	RS8564	Tape and Reel,4000
RS8564XQ	TSSOP-14	14	4	-40°C ~125°C	RS8564	Tape and Reel,4000

## NOTE:

- (1) There may be additional marking, which relates to the lot trace code information (data code and vendor code), the logo or the environmental category on the device.



## ELECTRICAL CHARACTERISTICS

Boldface limits apply over the specified temperature range,  $T_A = -40^{\circ}\text{C}$  to  $+125^{\circ}\text{C}$ .

(At  $T_A = +25^{\circ}\text{C}$ ,  $V_S = 5\text{V}$ ,  $R_L = 10\text{k}\Omega$  connected to  $V_S/2$ , and  $V_{OUT} = V_S/2$ , unless otherwise noted.)

PARAMETER	SYMBOL	CONDITION	RS8561, RS8562, RS8563, RS8564			
			MIN	TYP	MAX	UNIT
<b>OFFSET VOLTAGE</b>						
Input Offset Voltage	$V_{OS}$	$V_{CM} = V_S/2$	-20	$\pm 3$	20	$\mu\text{V}$
Input Offset Voltage Average Drift	$V_{OS} T_C$			$\pm 0.1$	$\pm 0.4$	$\mu\text{V}/^{\circ}\text{C}$
Power-Supply Rejection Ratio	PSRR	$V_S = +2.9\text{V}$ to $+5.5\text{V}$ , $V_{CM} = 0$	100	120		dB
Channel Separation, dc				0.1		$\mu\text{V}/\text{V}$
<b>INPUT BIAS CURRENT</b>						
Input Bias Current	$I_B$	$V_{CM} = V_S/2$		$\pm 100$		pA
Input Offset Current	$I_{OS}$			$\pm 10$		pA
<b>NOISE PERFORMANCE</b>						
Input Voltage Noise	$e_n$ p-p	$f = 0.01\text{Hz}$ to $10\text{Hz}$		0.48		$\mu\text{Vpp}$
Input Voltage Noise	$e_n$ p-p	$f = 0.01\text{Hz}$ to $1\text{Hz}$		0.15		$\mu\text{Vpp}$
Input Voltage Noise Density	$e_n$	$f = 1\text{KHz}$		32		$\text{nV}/\sqrt{\text{Hz}}$
Input Current Noise Density	$i_n$	$f = 10\text{Hz}$		1.5		$\text{fA}/\sqrt{\text{Hz}}$
<b>INPUT VOLTAGE RANGE</b>						
Common-Mode Voltage Range	$V_{CM}$		(V-) -0.1		(V+) +0.1	V
Common-Mode Rejection Ratio	CMRR	$(V-) -0.1\text{V} < V_{CM} < (V+) + 0.1\text{V}$	100	120		dB
<b>INPUT CAPACITANCE</b>						
Differential				5		pF
Common-Mode				5		pF
<b>Open-Loop Gain</b>						
Open-Loop Voltage Gain	$A_{OL}$	$R_L = 10\text{K}\Omega$ , $V_O = 0.3\text{V}$ to $4.7\text{V}$ , $T_A = -40^{\circ}\text{C}$ to $125^{\circ}\text{C}$	100	120		dB
<b>DYNAMIC PERFORMANCE</b>						
Slew Rate	SR	$G = +1$		8.5		$\text{V}/\mu\text{s}$
Gain-Bandwidth Product	GBW			11		MHz
Overload Recovery Time	$t_{OR}$			0.4		$\mu\text{s}$
<b>OUTPUT CHARACTERISTICS</b>						
Output Voltage High	$V_{OH}$	$R_L = 100\text{K}\Omega$ to GND	4.99	4.998		V
		$R_L = 10\text{K}\Omega$ to GND	4.95	4.98		
Output Voltage Low	$V_{OL}$	$R_L = 100\text{K}\Omega$ to V+		1	10	mV
		$R_L = 10\text{K}\Omega$ to V+		10	30	
Short-Circuit Current	$I_{SC}$			65		mA
<b>POWER SUPPLY</b>						
Operating Voltage Range	$V_S$		2.9		5.5	V
Quiescent Current/ Amplifier	$I_Q$			1.3	1.55	mA
<b>SHUTDOWN</b>						
$t_{OFF}$				2		$\mu\text{s}$
$t_{ON}$				150		$\mu\text{s}$

$V_L$ (shutdown)			0		+0.8	V
$V_H$ (amplifier is active)			0.75 (V+)		V+	V
Input Bias Current of Enable Pin				50		pA
$I_{QSD}$				1	5	$\mu$ A

## TYPICAL CHARACTERISTICS

At  $T_A = +25^\circ\text{C}$ ,  $V_S = 5\text{V}$ ,  $R_L = 10\text{k}\Omega$  connected to  $V_S/2$ ,  $V_{OUT} = V_S/2$ , unless otherwise noted.

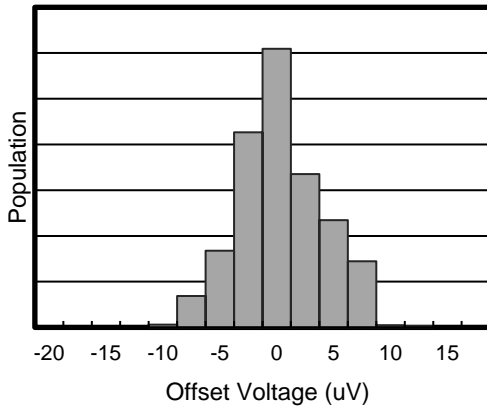

**Figure 1. Offset Voltage Production Distribution**

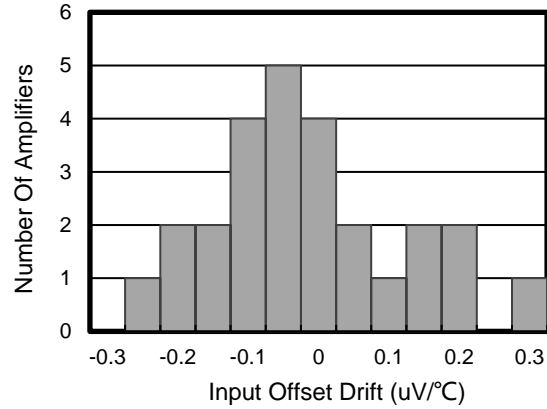

**Figure 2. Offset Voltage Drift Production Distribution**

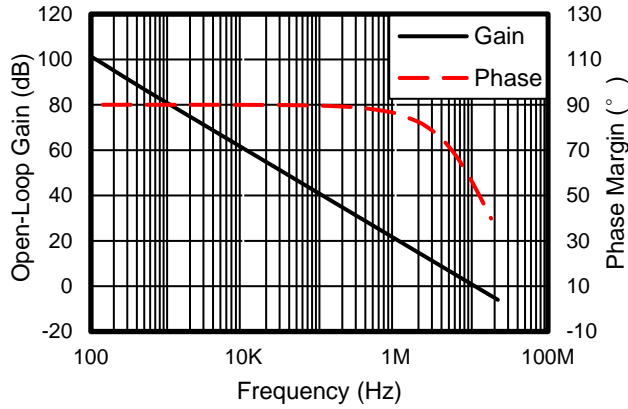

**Figure 3. Open-Loop Gain and Phase vs Frequency**

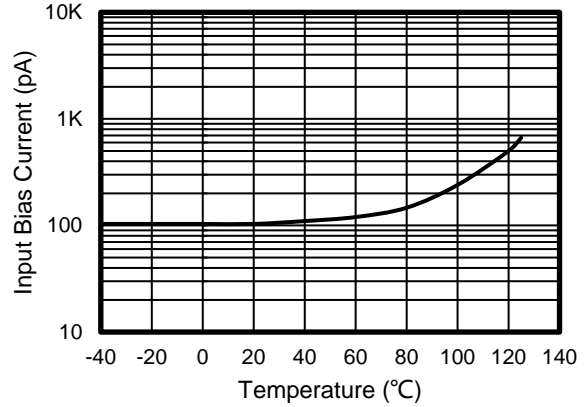

**Figure 4. Input Bias Current vs Temperature**

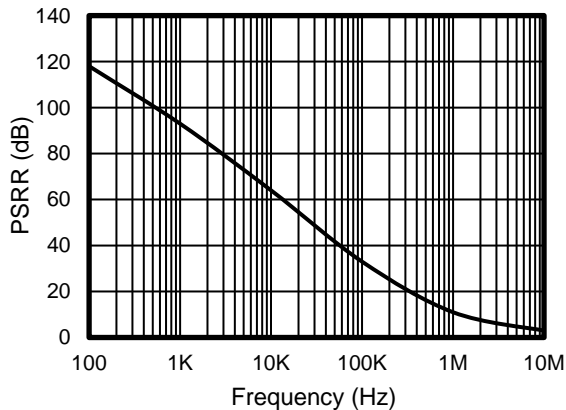

**Figure 5. Power-Supply Rejection Ratio vs Frequency**

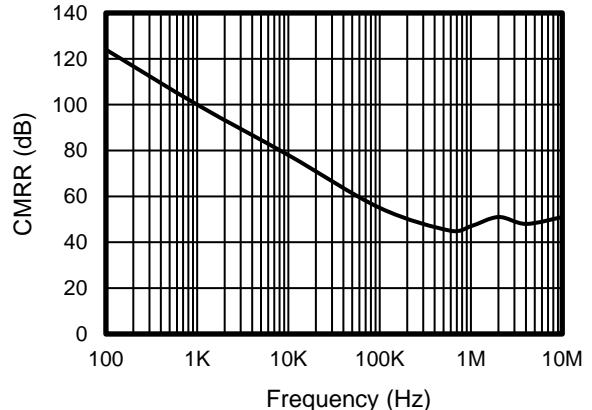

**Figure 6. Common-Mode Rejection Ratio vs Frequency**

## TYPICAL CHARACTERISTICS

At  $T_A = +25^\circ\text{C}$ ,  $V_S = 5\text{V}$ ,  $R_L = 10\text{k}\Omega$  connected to  $V_S/2$ ,  $V_{OUT} = V_S/2$ , unless otherwise noted.

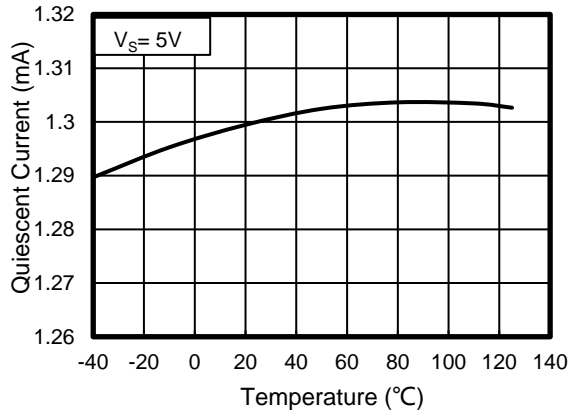

Figure 7. Quiescent Current vs Temperature

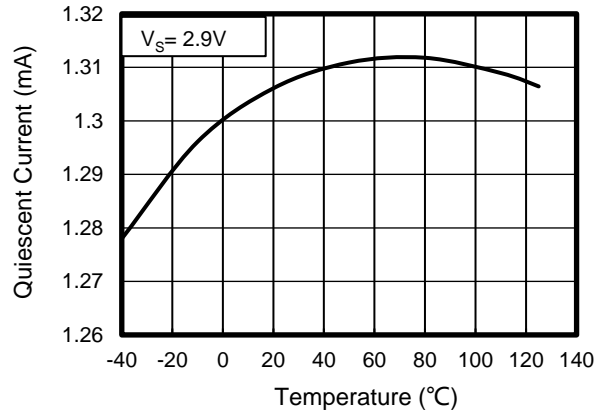

Figure 8. Quiescent Current vs Temperature

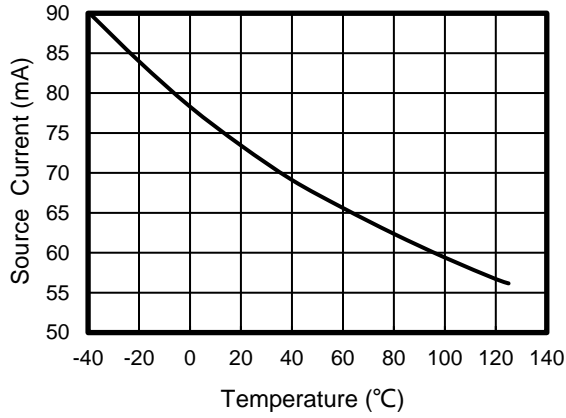

Figure 9. Source Current vs Temperature

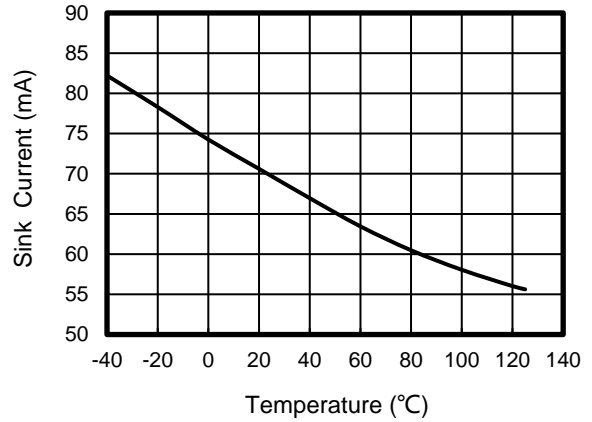

Figure 10. Sink Current vs Temperature

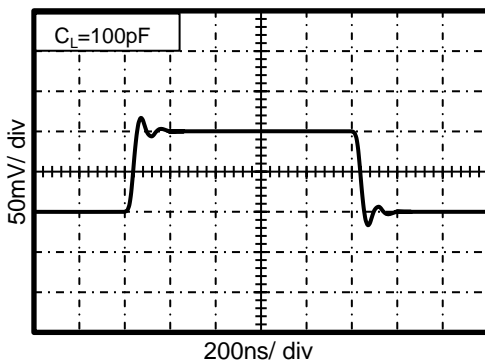

Figure 11. Small-Signal Step Response

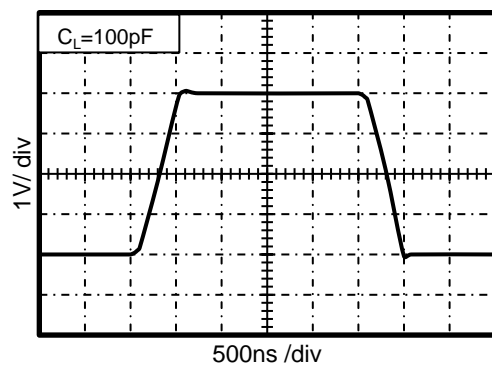

Figure 12. Large-Signal Step Response

## TYPICAL CHARACTERISTICS

At  $T_A = +25^\circ\text{C}$ ,  $V_S = 5\text{V}$ ,  $R_L = 10\text{k}\Omega$  connected to  $V_S/2$ ,  $V_{OUT} = V_S/2$ , unless otherwise noted.

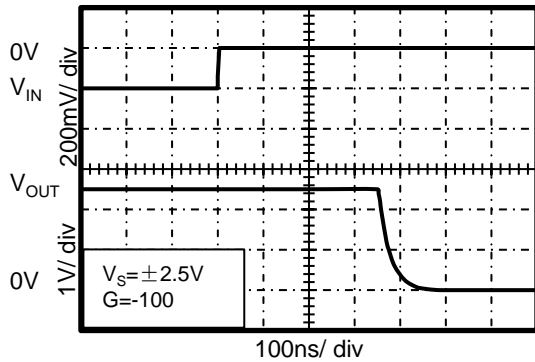

Figure 13. Positive Overtolerance Recovery

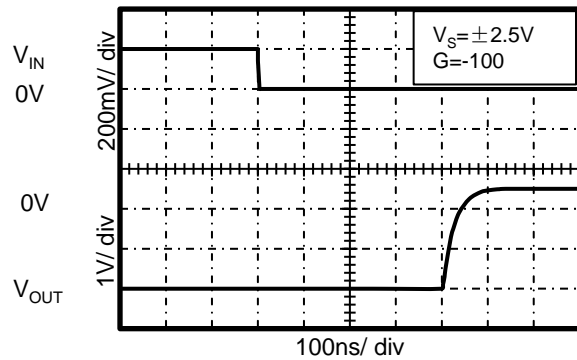

Figure 14. Negative Overtolerance Recovery

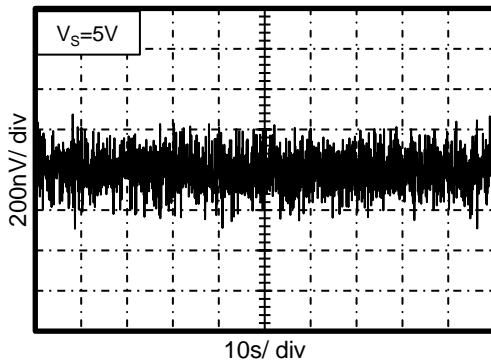

Figure 15. 0.01Hz to 10Hz Noise

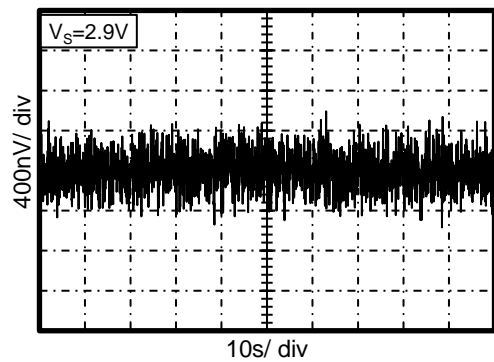

Figure 16. 0.01Hz to 10Hz Noise

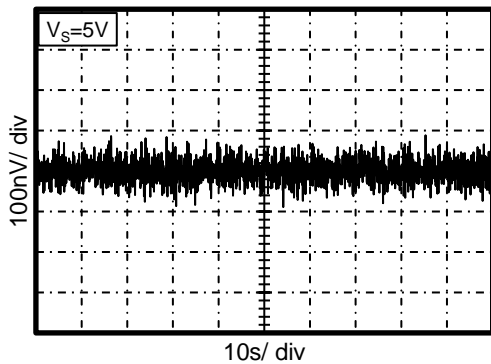

Figure 17. 0.01Hz to 1Hz Noise

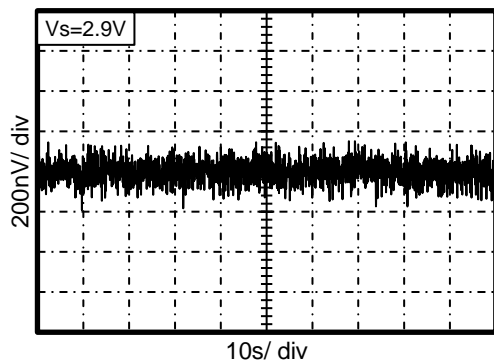

Figure 18. 0.01Hz to 1Hz Noise

## Detailed Description

### Overview

The RS8561, RS8562, RS8563, RS8564 series op amps are unity-gain stable and free from unexpected output phase reversal. They use auto-zeroing techniques to provide low offset voltage and very low drift over time and temperature.

Good layout practice mandates use of a 0.1  $\mu$ F capacitor placed closely across the supply pins.

For lowest offset voltage and precision performance, circuit layout and mechanical conditions should be optimized. Avoid temperature gradients that create thermoelectric (Seebeck) effects in thermocouple junctions formed from connecting dissimilar conductors. These thermally-generated potentials can be made to cancel by assuring that they are equal on both input terminals.

- Use low thermoelectric-coefficient connections (avoid dissimilar metals).
- Thermally isolate components from power supplies or other heat-sources.
- Shield op amp and input circuitry from air currents, such as cooling fans.

Following these guidelines will reduce the likelihood of junctions being at different temperatures, which can cause thermoelectric voltages of 0.1  $\mu$ V/ $^{\circ}$ C or higher, depending on materials used.

### OPERATING VOLTAGE

The RS8561, RS8562, RS8563, RS8564 series op amps operate over a power-supply range of +2.9V to +5.5V ( $\pm$ 1.45V to  $\pm$ 2.75V). Supply voltages higher than 7V (absolute maximum) can permanently damage the amplifier. Parameters that vary over supply voltage or temperature are shown in the typical characteristics section of this data sheet.

### RS8563 ENABLE FUNCTION

The enable/shutdown digital input is referenced to the V- supply voltage of the amp. A logic high enables the op amp. A valid logic high is defined as > 75% of the total supply voltage. The valid logic high signal can be up to 5.5V above the negative supply, independent of the positive supply voltage. A valid logic low is defined as < 0.8V above the V- supply pin. If dual or split power supplies are used, be sure that logic input signals are properly referred to the negative supply voltage. The enable pin must be connected to a valid high or low voltage, or driven, not left open circuit.

The logic input is a high-impedance CMOS input, with separate logic inputs provided on the dual version. For battery operated applications, this feature can be used to greatly reduce the average current and extend battery life.

The enable time includes one full autozero cycle required by the amplifier to return to  $V_{OS}$  accuracy. Prior to this time, the amplifier functions properly, but with unspecified offset voltage.

Disable time is 1  $\mu$ s. When disabled, the output assumes a high-impedance state. This allows the RS8563 to be operated as a gated amplifier, or to have the output multiplexed onto a common analog output bus.

## APPLICATION NOTE

The RS856X is a unity-gain stable, precision operational amplifier with very low offset voltage drift; these devices are also free from output phase reversal. Applications with noisy or high-impedance power supplies require decoupling capacitors close to the device power-supply pins. In most cases, 0.1- $\mu$ F capacitors are adequate.

### Typical Applications

#### Bidirectional Current-Sensing

This single-supply, low-side, bidirectional current-sensing solution detects load currents from -1 A to 1 A. The single-ended output spans from 110 mV to 3.19 V. This design uses the RS856X because of its low offset voltage and rail-to-rail input and output. One of the amplifiers is configured as a difference amplifier and the other provides the reference voltage.

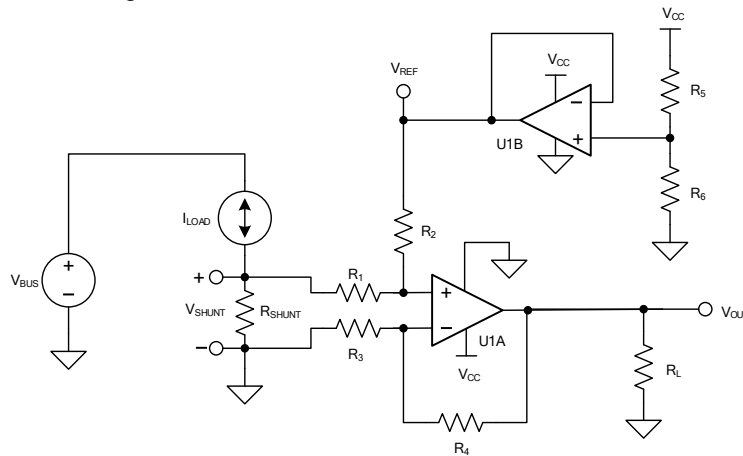

**Figure 19. Bidirectional Current-Sensing Schematic**

#### Design Requirements

This solution has the following requirements:

- Supply voltage: 3.3 V
- Input: -1 A to 1 A
- Output: 1.65 V  $\pm$  1.54 V (110 mV to 3.19 V)

#### Detailed Design Procedure

The load current,  $I_{LOAD}$ , flows through the shunt resistor ( $R_{SHUNT}$ ) to develop the shunt voltage,  $V_{SHUNT}$ . The shunt voltage is then amplified by the difference amplifier, which consists of U1A and  $R_1$  through  $R_4$ . The gain of the difference amplifier is set by the ratio of  $R_4$  to  $R_3$ . To minimize errors, set  $R_2 = R_4$  and  $R_1 = R_3$ . The reference voltage,  $V_{REF}$ , is supplied by buffering a resistor divider using U1B. The transfer function is given by Equation 1.

$$V_{OUT} = V_{SHUNT} \times \text{Gain}_{\text{Diff\_Amp}} + V_{REF}$$

Where

$$V_{SHUNT} = I_{LOAD} \times R_{SHUNT}$$

$$\text{Gain}_{\text{Diff\_Amp}} = \frac{R_4}{R_3}$$

$$V_{REF} = V_{CC} \times \left( \frac{R_6}{R_5 + R_6} \right) \quad (1)$$

There are two types of errors in this design: offset and gain. Gain errors are introduced by the tolerance of the shunt resistor and the ratios of  $R_4$  to  $R_3$  and, similarly,  $R_2$  to  $R_1$ . Offset errors are introduced by the voltage divider ( $R_5$  and  $R_6$ ) and how closely the ratio of  $R_4/R_3$  matches  $R_2/R_1$ . The latter value impacts the CMRR of the difference amplifier, which ultimately translates to an offset error. Because this is a low-side measurement, the value of  $V_{SHUNT}$  is the ground potential for the system load. Therefore, it is important to place a maximum value on  $V_{SHUNT}$ . In this design, the maximum value for  $V_{SHUNT}$  is set to 100 mV. Equation 2 calculates the maximum value of the shunt resistor given a maximum shunt voltage of 100 mV and maximum load current of 1 A.

$$R_{SHUNT(\text{Max})} = \frac{V_{SHUNT(\text{Max})}}{I_{LOAD(\text{Max})}} = \frac{100 \text{ mV}}{1 \text{ A}} = 100 \text{ m}\Omega \quad (2)$$

## APPLICATION NOTE

The tolerance of  $R_{SHUNT}$  is directly proportional to cost. For this design, a shunt resistor with a tolerance of 0.5% was selected. If greater accuracy is required, select a 0.1% resistor or better.

The load current is bidirectional; therefore, the shunt voltage range is -100 mV to 100 mV. This voltage is divided down by  $R_1$  and  $R_2$  before reaching the operational amplifier, U1A. Take care to ensure that the voltage present at the noninverting node of U1A is within the common-mode range of the device. Therefore, it is important to use an operational amplifier, such as the RS856X, that has a common-mode range that extends below the negative supply voltage. Finally, to minimize offset error, note that the RS856X has a typical offset voltage of  $\pm 3\mu\text{V}$  ( $\pm 20\mu\text{V}$  maximum). Given a symmetric load current of -1 A to 1 A, the voltage divider resistors ( $R_5$  and  $R_6$ ) must be equal. To be consistent with the shunt resistor, a tolerance of 0.5% was selected. To minimize power consumption, 10k $\Omega$  resistors were used. To set the gain of the difference amplifier, the common-mode range and output swing of the RS856X must be considered. Equation 3 and Equation 4 depict the typical common-mode range and maximum output swing, respectively, of the RS856X given a 3.3V supply.

$$-100\text{mV} < V_{CM} < 3.4\text{V} \quad (3)$$

$$100\text{mV} < V_{OUT} < 3.2\text{V} \quad (4)$$

The gain of the difference amplifier can now be calculated as shown in Equation 5.

$$\text{Gain}_{\text{Diff\_Amp}} = \frac{V_{OUT\_Max} - V_{OUT\_Min}}{R_{SHUNT} \times (I_{MAX} - I_{MIN})} = \frac{3.2\text{ V} - 100\text{ mV}}{100\text{ m}\Omega \times [1\text{ A} - (-1\text{ A})]} = 15.5 \frac{\text{V}}{\text{V}} \quad (5)$$

The resistor value selected for  $R_1$  and  $R_3$  was 1k $\Omega$ . 15.4k $\Omega$  was selected for  $R_2$  and  $R_4$  because it is the nearest standard value. Therefore, the ideal gain of the difference amplifier is 15.4 V/V.

The gain error of the circuit primarily depends on  $R_1$  through  $R_4$ . As a result of this dependence, 0.1% resistors were selected. This configuration reduces the likelihood that the design requires a two-point calibration. A simple one-point calibration, if desired, removes the offset errors introduced by the 0.5% resistors.

### Application Curve

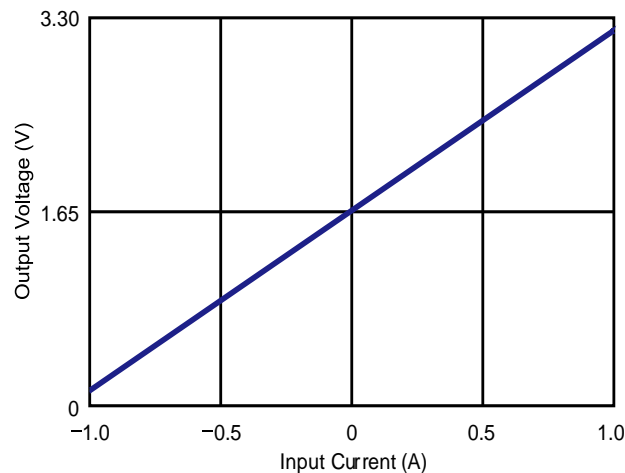

**Figure 20. Bidirectional Current-Sensing Circuit Performance: Output Voltage vs Input Current**



## LAYOUT

### Layout Guidelines

Attention to good layout practices is always recommended. Keep traces short. When possible, use a PCB ground plane with surface-mount components placed as close to the device pins as possible. Place a 0.1uF capacitor closely across the supply pins.

These guidelines should be applied throughout the analog circuit to improve performance and provide benefits such as reducing the EMI susceptibility.

### Layout Example

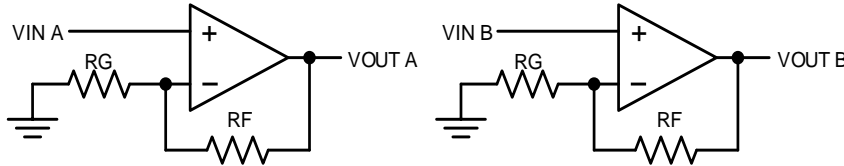

Figure 21. Schematic Representation

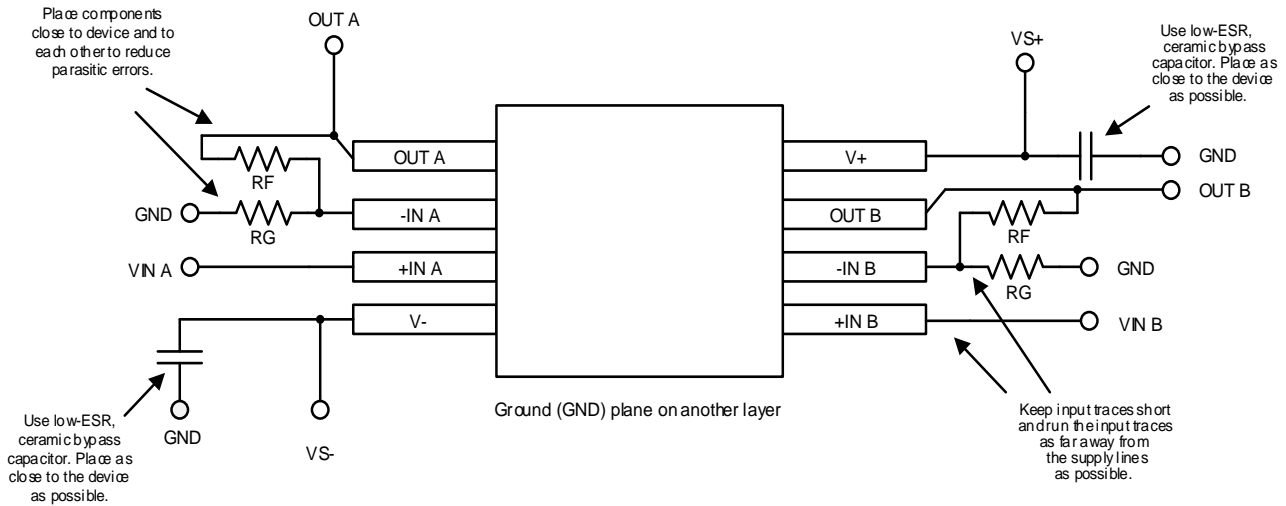
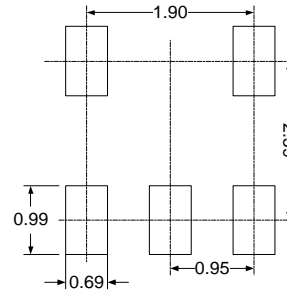
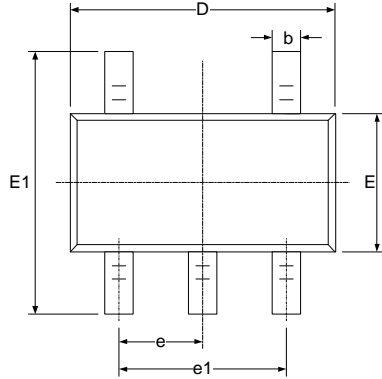
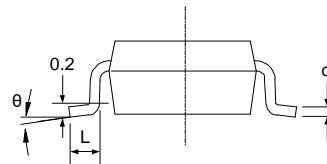
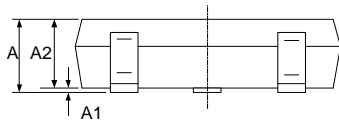
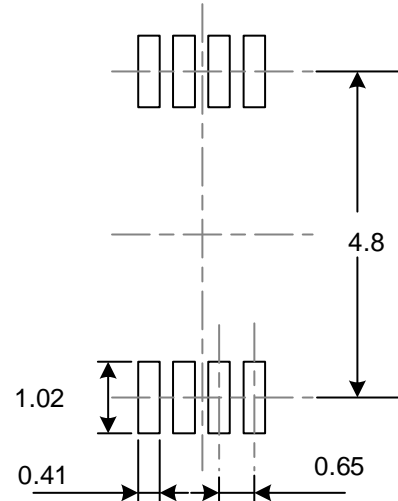
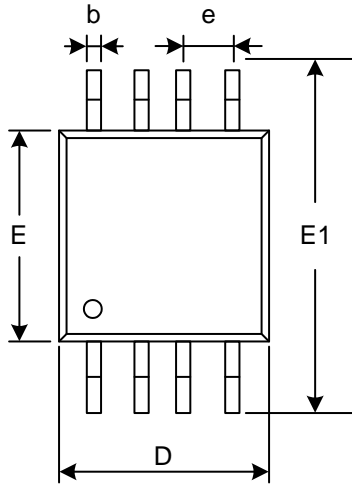
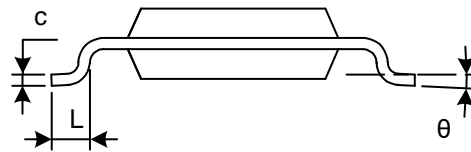
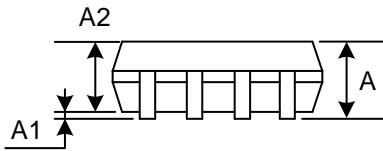

Figure 22. Layout Example

**PACKAGE OUTLINE DIMENSIONS**  
**SOT23-5**

**RECOMMENDED LAND PATTERN (Unit: mm)**

Symbol	Dimensions In Millimeters		Dimensions In Inches	
	Min	Max	Min	Max
A	1.050	1.250	0.041	0.049
A1	0.000	0.100	0.000	0.004
A2	1.050	1.150	0.041	0.045
b	0.300	0.500	0.012	0.020
c	0.100	0.200	0.004	0.008
D	2.820	3.020	0.111	0.119
E	1.500	1.700	0.059	0.067
E1	2.650	2.950	0.104	0.116
e	0.950(BSC)		0.037(BSC)	
e1	1.800	2.000	0.071	0.079
L	0.300	0.600	0.012	0.024
$\theta$	0°	8°	0°	8°

**MSOP-8**

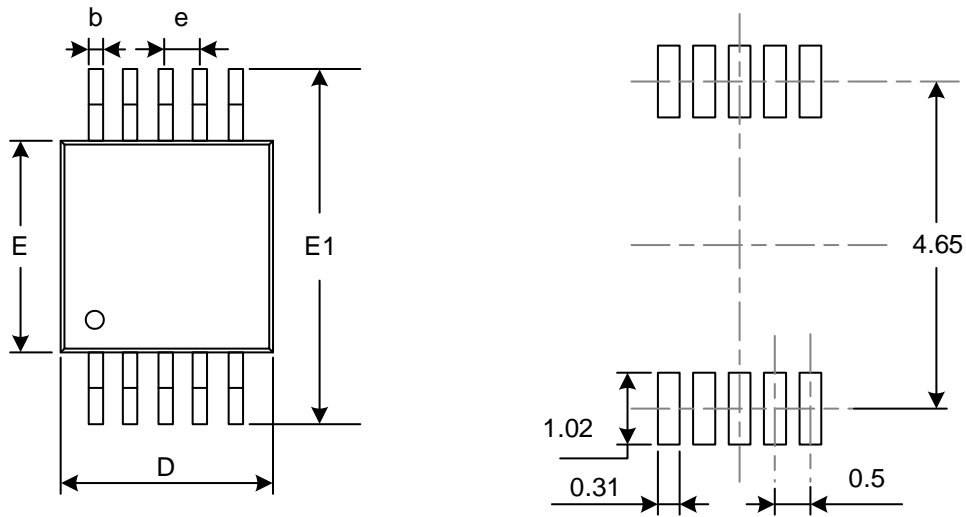
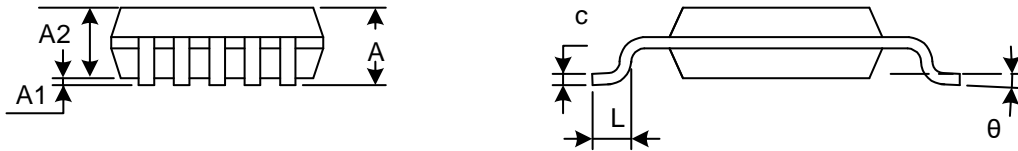
**RECOMMENDED LAND PATTERN (Unit: mm)**

Symbol	Dimensions In Millimeters		Dimensions In Inches	
	Min	Max	Min	Max
A	0.820	1.100	0.032	0.043
A1	0.020	0.150	0.001	0.006
A2	0.750	0.950	0.030	0.037
b	0.250	0.380	0.010	0.015
c	0.090	0.230	0.004	0.009
D	2.900	3.100	0.114	0.122
e	0.650(BSC)		0.026(BSC)	
E	2.900	3.100	0.114	0.122
E1	4.750	5.050	0.187	0.199
L	0.400	0.800	0.016	0.031
$\theta$	0°	6°	0°	6°

**MSOP-10**

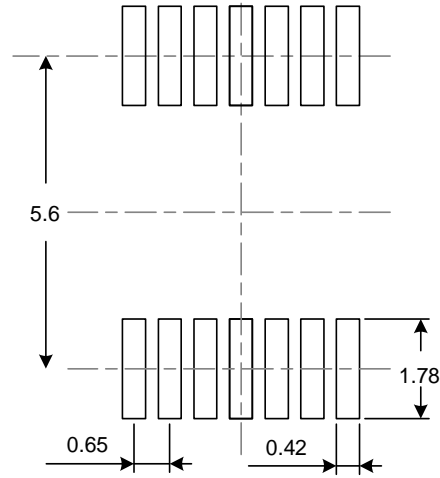
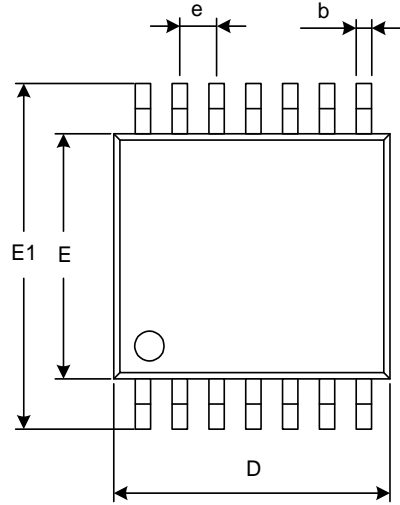
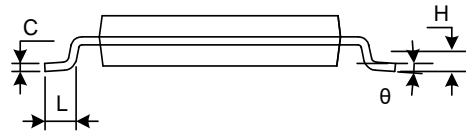
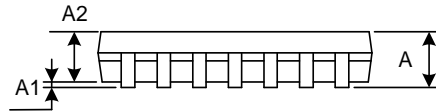
**RECOMMENDED LAND PATTERN (Unit: mm)**

Symbol	Dimensions In Millimeters		Dimensions In Inches	
	Min	Max	Min	Max
A	0.820	1.100	0.032	0.043
A1	0.020	0.150	0.001	0.006
A2	0.750	0.950	0.030	0.037
b	0.180	0.280	0.007	0.011
c	0.090	0.230	0.004	0.009
D	2.900	3.100	0.114	0.122
e	0.50(BSC)		0.020(BSC)	
E	2.900	3.100	0.114	0.122
E1	4.750	5.050	0.187	0.199
L	0.400	0.800	0.016	0.031
θ	0°	6°	0°	6°

**TSSOP-14**

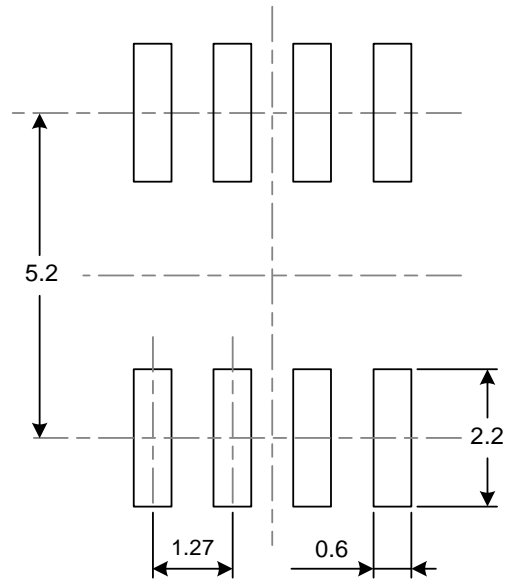
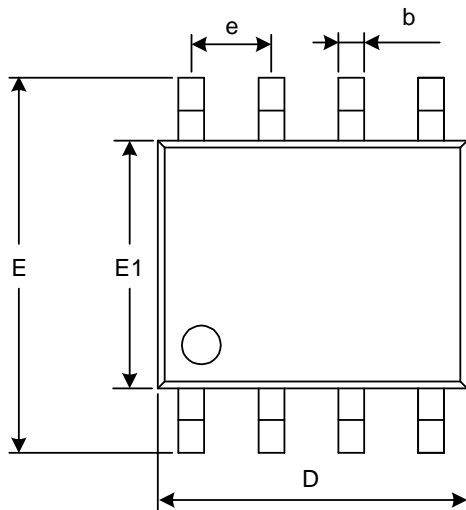
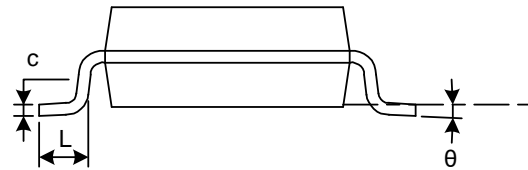
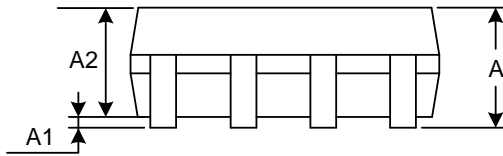
**RECOMMENDED LAND PATTERN (Unit: mm)**

Symbol	Dimensions In Millimeters		Dimensions In Inches	
	Min	Max	Min	Max
A		1.200		0.047
A1	0.050	0.150	0.002	0.006
A2	0.800	1.050	0.031	0.041
b	0.190	0.300	0.007	0.012
c	0.090	0.200	0.004	0.008
D	4.860	5.100	0.191	0.201
E	4.300	4.500	0.169	0.177
E1	6.250	6.550	0.246	0.258
e	0.650(BSC)		0.026(BSC)	
L	0.500	0.700	0.020	0.028
H	0.25(TYP)		0.01(TYP)	
$\theta$	1°	7°	1°	7°

**SOIC-8 (SOP8)**

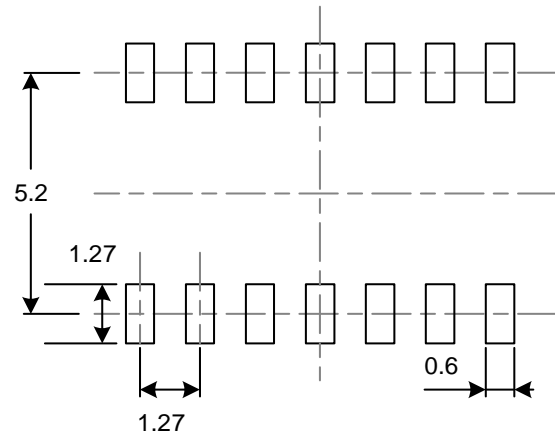
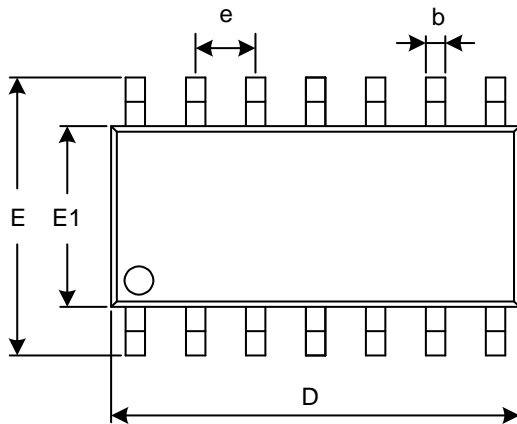
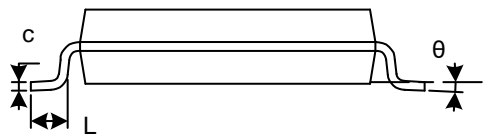
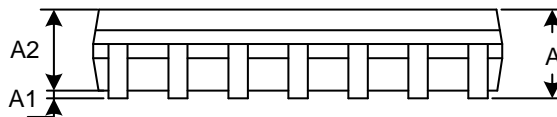
**RECOMMENDED LAND PATTERN (Unit: mm)**

Symbol	Dimensions In Millimeters		Dimensions In Inches	
	Min	Max	Min	Max
A	1.350	1.750	0.053	0.069
A1	0.100	0.250	0.004	0.010
A2	1.350	1.550	0.053	0.061
b	0.330	0.510	0.013	0.020
c	0.170	0.250	0.007	0.010
D	4.800	5.000	0.189	0.197
e	1.270(BSC)		0.050(BSC)	
E	5.800	6.200	0.228	0.244
E1	3.800	4.000	0.150	0.157
L	0.400	1.270	0.016	0.050
$\theta$	0°	8°	0°	8°

**SOIC-14 (SOP14)**

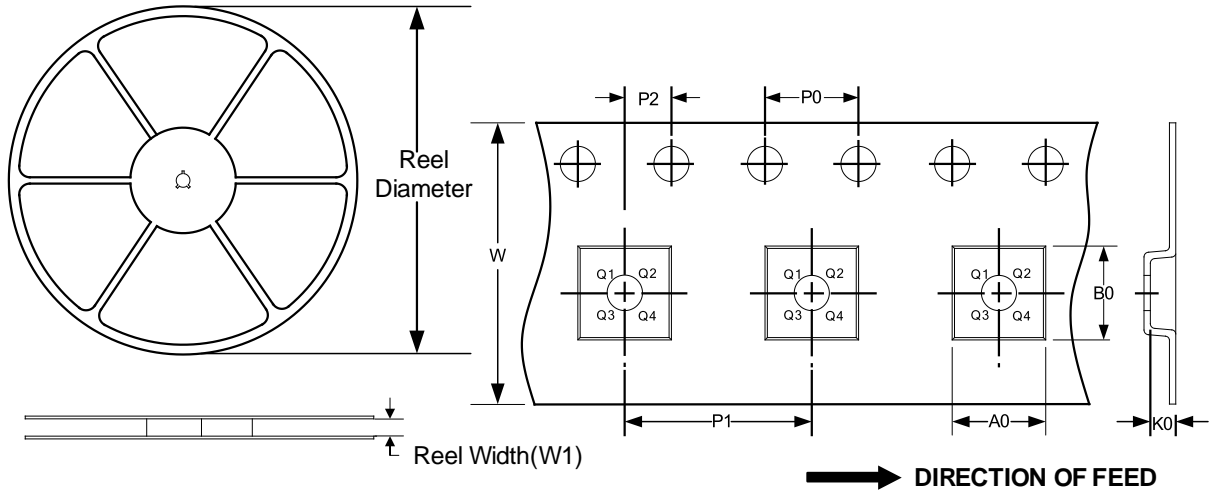
**RECOMMENDED LAND PATTERN (Unit: mm)**

Symbol	Dimensions In Millimeters		Dimensions In Inches	
	Min	Max	Min	Max
A	1.350	1.750	0.053	0.069
A1	0.100	0.250	0.004	0.010
A2	1.350	1.550	0.053	0.061
b	0.310	0.510	0.012	0.020
c	0.100	0.250	0.004	0.010
D	8.450	8.850	0.333	0.348
e	1.270(BSC)		0.050(BSC)	
E	5.800	6.200	0.228	0.244
E1	3.800	4.000	0.150	0.157
L	0.400	1.270	0.016	0.050
$\theta$	0°	8°	0°	8°

**TAPE AND REEL INFORMATION**  
**REEL DIMENSIONS**
**TAPE DIMENSION**

NOTE: The picture is only for reference. Please make the object as the standard.

**KEY PARAMETER LIST OF TAPE AND REEL**

Package Type	Reel Diameter	Reel Width (mm)	A0 (mm)	B0 (mm)	K0 (mm)	P0 (mm)	P1 (mm)	P2 (mm)	W (mm)	Pin1 Quadrant
SOT23-5	7"	9.5	3.20	3.20	1.40	4.0	4.0	2.0	8.0	Q3
MSOP8	13"	12.4	5.20	3.30	1.50	4.0	8.0	2.0	12.0	Q1
TSSOP14	13"	12.4	6.95	5.60	1.20	4.0	8.0	2.0	12.0	Q1
SOIC-8 (SOP8)	13"	12.4	6.40	5.40	2.10	4.0	8.0	2.0	12.0	Q1
SOIC-14 (SOP14)	13"	16.4	6.60	9.30	2.10	4.0	8.0	2.0	16.0	Q1
MSOP-10	13"	12.4	5.20	3.30	1.20	4.0	8.0	2.0	12.0	Q1