

SLIDE SHELL OPEN

NOTES:

1.MATERIAL:

- 1).HOUSING MATERIAL:THERMOPLASTIC UL94V-0;COLOR:BLACK
- 2).CONTACT MATERIAL:COPPERALLOY,T=0.15mm
- 3).SHELLMATERIAL:STAINLESS STEEL,T=0.20mm

2.FINISH:

- 1).CONTACT FINISH:50u"min.NICKEL UNDER PLATED,PLATED 3u"Au ON CONTACTAREA:TIN-PLATED HIGH-TEMPER ATURR 80u"-120u"ON SOLDER AREA
- 2).SHELL FINISH:Cleaning.

3.ELECTRICAL SPECIFICATIONS.

- 1).OPERATING VOLTAGE: 250V(AC/DC)
- 2).CURRENT RATING:0.5A.
- 3).OPERATING TEMPERATURE: -20°C~+65C.
- 4).INSULATION RESISTANCE: 1000M OHMS min, at 250VDC.
- 5).DIELECTRIC WITHSTANDING VOLTAGE:500VAC/1minute.
- 6).CONTACT RESISTANCE:100m OHMS max.



SLIDE SHELL LOCK

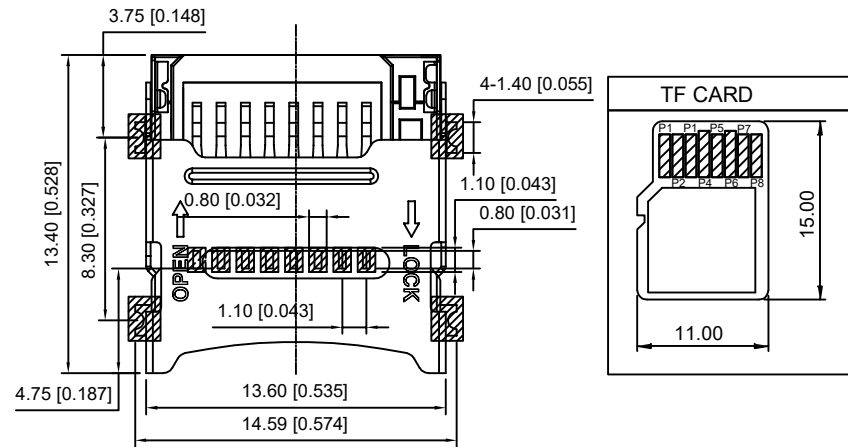
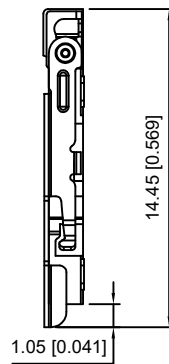
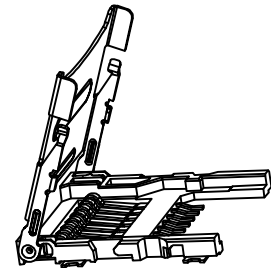

RECOMMENDED PCB LAYOU  
TOLERANCE ±0.05

new		2015/5/3		A		瀚源	
ECN BO.		DESCRIPTION.		DATE.			
DESIGNED	CHECKED	APPROVAL	DRAWING NUMBER	SCALT: 1/2		SCALE: 3:1	
Mikey	Tom	Jerry	PART NAME	TF-1307-18	UNLESS OTHERWISE SPECIFIED,TOLERANCE:	X.	±0.2f
			MODEL NAME	TF-1307-18		X.x	±0.2f
			3RD ANGLE PROJ	HanElectricity Co.,LTD		X.xx	±0.1f
						ANGULAIR	±3
						FILE.NO.	