

CH481

AEC-Q100 Qualified, Programmable Hall Effect Digital Sensor

This is advanced information on a new product now in development or undergoing evaluation. Details are subject to change without notice and Cosemittech assumes no obligation for future manufacture of this product. Contact Cosemittech for the latest status.

Features

- AEC-Q100 automotive qualified
- Customer-programmable operate point, Output polarity, Hysteresis (switch or latch), Output falling time for reduced EMI
- Factory-programmable TC of operate points
- Chopper stabilization for stable operate points throughout operating temperature range
- On board voltage regulator for 2.8V to 30V range
- Resistant to physical stress
- Output short-circuit protection
- Operation from unregulated supply
- Reverse-battery and freewheeling protection
- On-chip protection against Supply transients
- Wide Operating temperature range: -40 to 150 °C
- Small package sizes TO-92S, SOT-23 and SOT-89
- RoHS-compliant material meets directive 2011/65/EU

Package

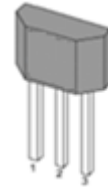

TO-92S

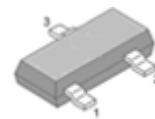

SOT-23



SOT-89

Application

- Brushless dc (direct current) motor commutation
- Motor and fan control
- Robotics control
- Speed and RPM sensing
- Tachometer, counter pickup
- Flow-rate sensing
- Automobile gear shifter

Functional Block Diagram

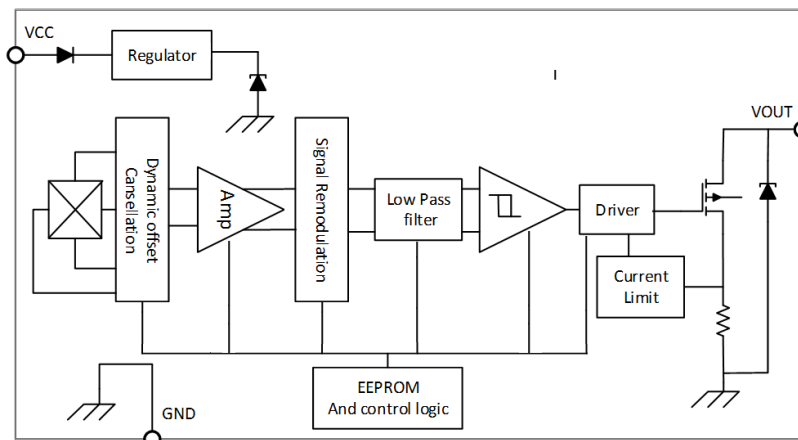

Description

The CH481 Hall-effect sensor is extremely temperature-stable and stress-resistant sensor ICs, especially suited for operation over extended temperature ranges from -40°C to 150°C. Superior high temperature performance is possible through dynamic offset cancellation, which reduces the residual offset voltage normally caused by device over-molding, temperature dependencies, and thermal stress.

The device includes a voltage regulator, Hall-voltage generator, small-signal amplifier, chopper stabilization, Schmitt trigger, and a short circuit protected open-drain output to sink up to 25 mA.

An on-board regulator permits operation with supply voltages of 2.8 to 30 V. The advantage of operating down to 2.8 V is that the device can be used in 2.8 V applications or with additional external resistance in series with the supply pin for greater protection against high-voltage transient events.

The CH481 can be programmed as a latch switch. Normally a south pole of sufficient strength turns on the output; however, the output polarity can be changed by programming EEPROM.

The falling time of driver can be programmed to reduce the EMI in automotive applications.

The CH481 also has integrated internal clamps against supply transients; output short circuit protection; reverse battery conditions.

Three package styles provide a magnetically optimized package for most applications, SOT-23, SOT-89 and TO-92S. Each package type is lead (Pb) free (suffix, -T), with a 100% matte-tin-plated lead-frame.

Revision History

| Date | Revision | Change |
|-----------|----------|--|
| Oct 2018 | 0.1 | Draft |
| Feb 2019 | 0.2 | 1. Fixed some characteristic value errors |
| July 2021 | 0.3 | 1. Updated format 2. Fixed the maximum electric characteristic. |
| Dec 2021 | 0.4 | Fixed 9.3 output stage Figure 1 R1 location |

Table of Contents

| | | |
|-----------|---|-----------|
| 1 | PRODUCT FAMILY MEMBERS | 4 |
| 2 | PIN DEFINITIONS AND DESCRIPTIONS | 5 |
| 3 | ABSOLUTE MAXIMUM RATINGS | 5 |
| 4 | ESD PROTECTIONS | 5 |
| 5 | FUNCTION DESCRIPTION..... | 6 |
| 6 | MAGNETIC ACTIVATION..... | 6 |
| 7 | TEMPERATURE CHARACTERISTICS | 6 |
| 8 | PARAMETERS SPECIFICATION | 7 |
| 9 | APPLICATION INFORMATION | 9 |
| 10 | PACKAGE INFORMATION: | 13 |

1 Product Family Members

| Part Number | Marking ID | Description |
|-----------------------|------------|---|
| CH481LX0SR_XXX_XXX_XX | C481 | Bipolar latching, Hall-effect digital sensor IC, SOT-23-3L package, tape and reel packing (3000 units per reel) |
| CH481LX0TB_XXX_XXX_XX | C481 | Bipolar latching, Hall-effect digital sensor IC, flat, TO-92S package, bulk packing (1000 units per bag) |
| CH481LX0ER_XXX_XXX_XX | C481 | Bipolar latching, Hall-effect digital sensor IC, SOT-89-3L package, tape and reel packing (1000 units per reel) |
| CH481LX1SR_XXX_XXX_XX | C481 | Bipolar latching, Hall-effect digital sensor IC, SOT-23-3L package, tape and reel packing (3000 units per reel) |
| CH481LX1TB_XXX_XXX_XX | C481 | Bipolar latching, Hall-effect digital sensor IC, flat, TO-92S package, bulk packing (1000 units per bag) |
| CH481LX1ER_XXX_XXX_XX | C481 | Bipolar latching, Hall-effect digital sensor IC, SOT-89-3L package, tape and reel packing (1000 units per reel) |
| CH481U00SR_XXX_XXX_XX | C481 | Unipolar, Hall-effect digital sensor IC, SOT-23-3L package, tape and reel packing (3000 units per reel) |
| CH481U00TB_XXX_XXX_XX | C481 | Unipolar, Hall-effect digital sensor IC, flat, TO-92S package, bulk packing (1000 units per bag) |
| CH481U01ER_XXX_XXX_XX | C481 | Unipolar, Hall-effect digital sensor IC, SOT-89-3L package, tape and reel packing (1000 units per reel) |
| CH481U01SR_XXX_XXX_XX | C481 | Unipolar, Hall-effect digital sensor IC, SOT-23-3L package, tape and reel packing (3000 units per reel) |
| CH481U01TB_XXX_XXX_XX | C481 | Unipolar, Hall-effect digital sensor IC, flat, TO-92S package, bulk packing (1000 units per bag) |
| CH481U01ER_XXX_XXX_XX | C481 | Unipolar, Hall-effect digital sensor IC, SOT-89-3L package, tape and reel packing (1000 units per reel) |
| CH481U10SR_XXX_XXX_XX | C481 | Unipolar, Hall-effect digital sensor IC, SOT-23-3L package, tape and reel packing (3000 units per reel) |
| CH481U10TB_XXX_XXX_XX | C481 | Unipolar, Hall-effect digital sensor IC, flat, TO-92S package, bulk packing (1000 units per bag) |
| CH481U10ER_XXX_XXX_XX | C481 | Unipolar, Hall-effect digital sensor IC, SOT-89-3L package, tape and reel packing (1000 units per reel) |
| CH481U11SR_XXX_XXX_XX | C481 | Unipolar, Hall-effect digital sensor IC, SOT-23-3L package, tape and reel packing (3000 units per reel) |
| CH481U11TB_XXX_XXX_XX | C481 | Unipolar, Hall-effect digital sensor IC, flat, TO-92S package, bulk packing (1000 units per bag) |
| CH481U11ER_XXX_XXX_XX | C481 | Unipolar, Hall-effect digital sensor IC, SOT-89-3L package, tape and reel packing (1000 units per reel) |

CH481x is available in a variety of delivery forms. They are distinguished by a specific nomenclature code:

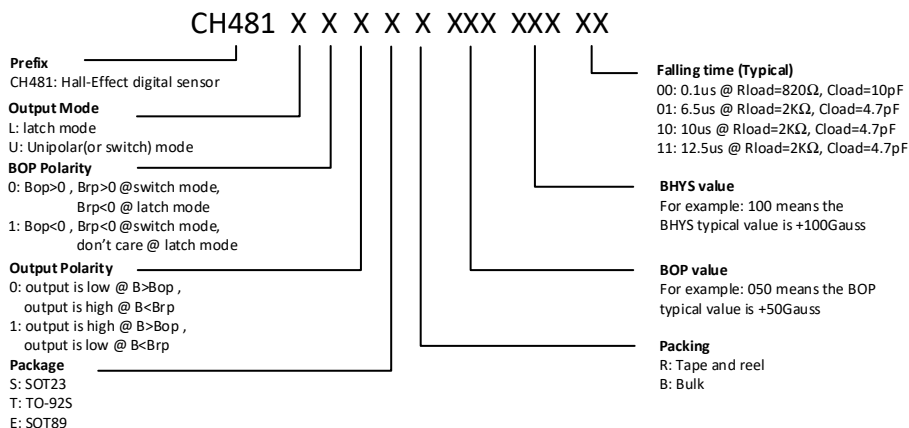

2 Pin Definitions and Descriptions

| SOT-23-3L (S) | TO-92S (T) | SOT-89-3L (E) | Name | Type | Function |
|---------------|------------|---------------|------|--------|-----------------------|
| 1 | 1 | 1 | VDD | Supply | Supply Voltage pin |
| 2 | 3 | 3 | OUT | Output | Open Drain Output pin |
| 3 | 2 | 2 | GND | Ground | Ground pin |

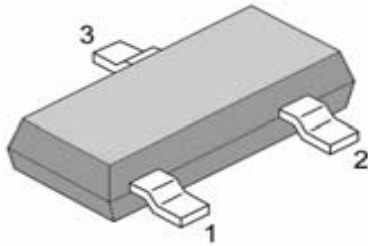
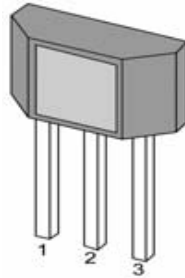
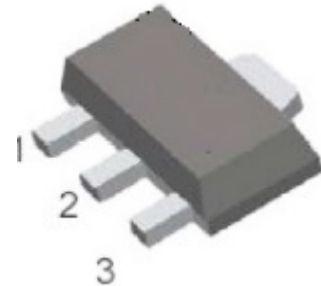
SOT-23-3L

TO-92S

SOT-89-3L

3 Absolute Maximum Ratings

| Parameter | Symbol | Min | Max | Units |
|--|------------------|----------|------------------|-------|
| Supply Voltage | V_{DD} | - | 28 | V |
| | | | 30 ¹⁾ | V |
| VDD Reverse Voltage VDD | V_{RDD} | -24 | | V |
| VDD Reverse Voltage (Pulse) ($T_{pulse} \leq 2\mu s$, $T_{cycle} \geq 1s$) | $V_{RDD(Pulse)}$ | -30 | | V |
| Supply Current | I_{DD} | - | 20 | mA |
| Output off Voltage | V_{OUT} | -0.3 | 30 | V |
| Output Current | I_{OUT} | - | 25 | mA |
| Operating Ambient Temperature | T_A | -40 | 150 | °C |
| Storage Temperature | T_S | -50 | 150 | °C |
| Junction temperature | T_J | -50 | 165 | °C |
| Magnetic Flux | B | No Limit | | Gauss |

1) $t < 5ms$, No cumulative stress

Note: Exceeding the absolute maximum ratings may cause permanent damage. Exposure to absolute-maximum-rated conditions for extended periods may affect device reliability.

4 ESD Protections

| Parameter | Value | Unit |
|------------------------|-------|------|
| All pins ¹⁾ | ±8000 | V |
| All pins ²⁾ | ±300 | V |
| All pins ³⁾ | ±2000 | V |

1) HBM (Human Body Mode) according to AEC-Q100-002

2) MM (Machine Mode) according to AEC-Q100-003

3) CDM (charged device mode) according to AEC-Q100-011

5 Function Description

The CH481 exhibits programmable latch/Unipolar magnetic switching characteristics. Therefore, it requires both south and north poles or signal magnetic polar to operate properly.

The Latch mode behaves as a latch with symmetric operating and release switching points ($BOP=|BRP|$). This means magnetic fields with equivalent strength and opposite direction drive the output high and low.

Removing the magnetic field ($B \rightarrow 0$), it keeps the output in its previous state. This latching property defines the device as a magnetic memory.

A magnetic hysteresis BHYST keeps BOP and BRP separated by a minimal value. This hysteresis prevents output oscillation near the switching point.

The unipolar mode behaves as a unipolar with asymmetric operating and release switching points. This means While the magnetic flux density (B) is larger than operate point (Bop), the output will be turned on (Low), while the magnetic flux density(B) is lower than release point (Brp), then turn off (High) or depend the program bit, the output characteristic can be reverse.

6 Magnetic Activation

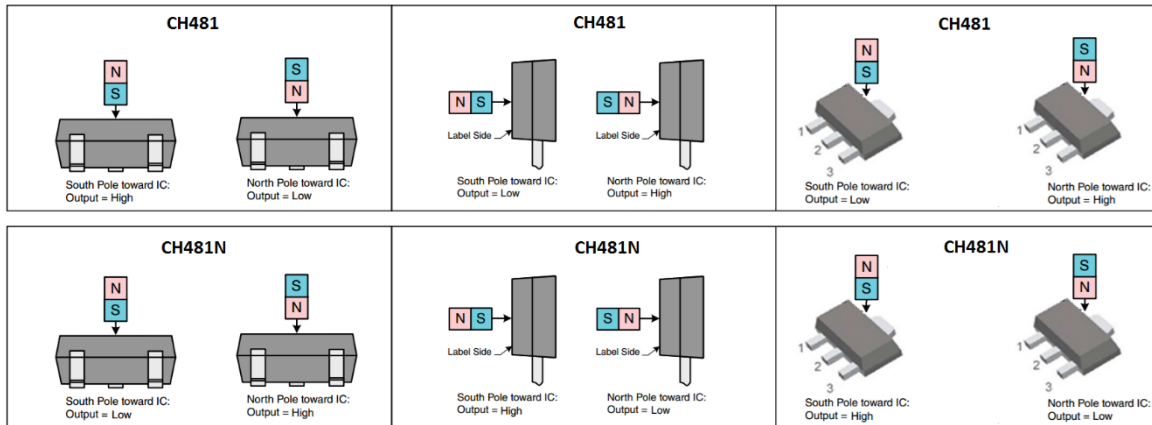

7 Temperature Characteristics

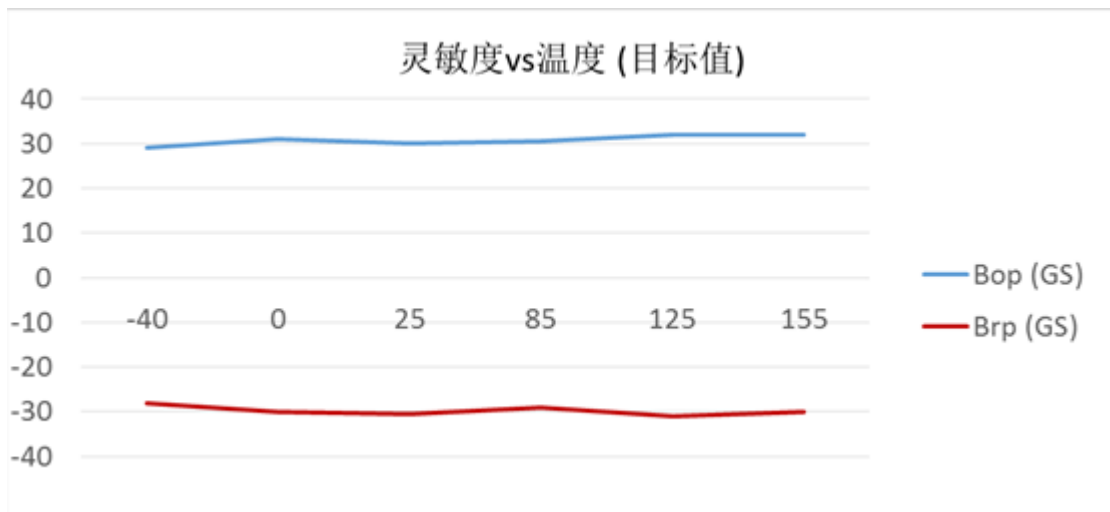

8 Parameters Specification

(VCC=3.3V supply, TA= -40 °C to 150 °C except where otherwise specified.)

| Symbol | Characteristic | Test Conditions | Min. | Typ. | Max. | Unit |
|-----------------------|---------------------------------|--|------|------|------|------|
| VCC | Supply Voltage | Operating, T _J < 165°C | 2.8 | | 28 | V |
| I _{CC} | Supply Current | No load on V _{OUT} | 1.0 | 1.6 | 4 | mA |
| V _{ZSUPPLY} | Supply Zener Clamp Voltage | I _{CC} = 7 mA; T _A = 25°C | 29.5 | – | – | V |
| V _{ZOUT} | Output Zener Clamp Voltage | I _{OUT} = 3mA | 28.5 | – | – | V |
| V _{RCC} | Reverse Battery Zener | | -24 | – | | V |
| I _{RCC} | Reverse Battery Current | V _{CC} = -24 V | – | – | -5 | mA |
| f _c | Chopping Frequency | | – | 500 | – | kHz |
| t _{PO} | Power-On Time | T _A = 25°C; C _{LOAD} = 10 pF | – | – | 30 | µs |
| POS | Power-On State ² | POL = 0; B < B _{RP} , t > t _{po} | – | High | – | – |
| | | POL = 1; B < B _{RP} , t > t _{po} | – | Low | – | – |
| V _{OUT(sat)} | Output Saturation Voltage | I _{OUT} = 20 mA | – | 175 | 400 | mV |
| I _{OFF} | Output Leakage Current | V _{OUT} = 26 V; Switch state = Off | – | – | 10 | µA |
| I _{OUT(lim)} | Output Current Limit | Short-Circuit Protection, Output = On | 30 | – | 90 | mA |
| t _r | Output Rise Time ^{3,4} | V _{CC} = 12 V, R _{LOAD} = 820 Ω, C _{LOAD} = 10 pF | – | – | 2 | µs |
| | | V _{CC} = 12 V, R _{LOAD} = 2 kΩ, C _{LOAD} = 4.7 nF | – | 21 | – | µs |
| t _r | Output Fall Time ^{3,4} | F _{time} = 00, V _{CC} = 12 V, R _{LOAD} = 820 Ω, C _{LOAD} = 10 pF | – | 0.1 | 2 | µs |
| | | F _{time} = 01, V _{CC} = 12 V, R _{LOAD} = 2 kΩ, C _{LOAD} = 4.7 nF | – | 6.5 | – | µs |
| | | F _{time} = 10, V _{CC} = 12 V, R _{LOAD} = 2 kΩ, C _{LOAD} = 4.7 nF | – | 10 | – | µs |
| | | F _{time} = 11, V _{CC} = 12 V, R _{LOAD} = 2 kΩ, C _{LOAD} = 4.7 nF | – | 12.5 | – | µs |
| POL | Output Polarity | POL=0, B>B _{OP} | – | Low | – | – |
| | | POL=0, B<B _{RP} | – | High | – | – |
| | | POL=1, B>B _{OP} | – | High | – | – |
| | | POL=1, B<B _{RP} | – | Low | – | – |
| BOP_init | Pre-Programming BOP Target | T _A = 25°C, BOPPOL = 0, mode=0 | – | 35 | – | G |
| | | T _A = 25°C, BOPPOL = 1, mode=0 | – | -35 | – | G |
| Bhys_init | Pre-Programming Hysteresis | B _{OP} - B _{RP} , mode=0 | 10 | 15 | 20 | G |
| BOP_init_L | Pre-Programming BOP Target | T _A = 25°C, mode=1 | – | 35 | – | G |
| BRP_init_L | Pre-Programming BRP Target | T _A = 25°C, mode=1 | – | -35 | – | G |

| | | | | | | |
|------------------------|---|--|-------|-------|------|------|
| Bhys_init_L | Pre-Programming Hysteresis | $B_{OP} - B_{RP}$, mode=1 | 50 | 70 | 90 | G |
| ΔBOP | Switch-point Thermal Drift ⁵ | LT package, $B_{OP} = \pm 450$ G | -0.14 | -0.03 | 0.08 | %/°C |
| | | UA package, $B_{OP} = \pm 450$ G | -0.08 | 0.00 | 0.08 | %/°C |
| Bit _{BOPSEL} | BOP Magnitude Selection Bits | | - | 8 | - | Bit |
| Res _{BOP} | BOP Step Size | Bit = LSB of BOPSEL | - | 3 | 6 | G |
| Bit _{BHYSSEL} | BHYS Magnitude Selection Bits | | - | 8 | - | Bit |
| Res _{BHYS} | BHYS Step Size | Bit = LSB of BRPSEL | - | 3 | 6 | G |
| Bit _{BOPPOL} | Switchpoint Polarity Bits | | - | 1 | - | Bit |
| Bit _{POL} | Output Polarity Bits | | - | 1 | - | Bit |
| Bit _{FALL} | Fall Time Bits | | - | 2 | - | Bit |
| Bit _{mode} | Modes Bits | | - | 1 | - | Bit |
| B_{OP} | Programmable BOP Range | $T_A = 25^\circ\text{C}$, BOPPOL = 1 (minimum at BOPSEL = 255, maximum at BOPSEL = 0), mode=0 | -450 | - | 10 | G |
| B_{OP} | Programmable BOP Range | $T_A = 25^\circ\text{C}$, BOPPOL = 0 (minimum at BOPSEL = 0, maximum at BOPSEL = 255), mode=0 | -10 | - | 450 | G |
| B_{HYS} | Programmable BRP Range | $T_A = 25^\circ\text{C}$, BOPPOL = 1 (minimum at BOPSEL = 255, maximum at BOPSEL = 0), mode=0 | -450 | - | 15 | G |
| B_{HYS} | Programmable BRP Range | $T_A = 25^\circ\text{C}$, BOPPOL = 0 (minimum at BOPSEL = 0, maximum at BOPSEL = 255), mode=0 | -15 | - | 450 | G |
| B_{OP_L} | Programmable BOP Range | $T_A = 25^\circ\text{C}$, BOPPOL = 0 (minimum at BOPSEL = 0, maximum at BOPSEL = 255), mode=1 | 7 | - | 450 | G |
| B_{RP_L} | Programmable BRP Range | $T_A = 25^\circ\text{C}$, BOPPOL = 1 (minimum at BOPSEL = 255, maximum at BOPSEL = 0), mode=1 | -450 | - | -7 | G |

- 1G (gauss) = 0.1 mT (millitesla).
- Output state when device configured reference to the application diagram.
- Output Rise Time is governed by external circuits tied to VOUT.
- Measured from 10% to 90% of the steady state output.

Internal trimming utilized to minimize switch-point drift over the operating temperature range.

NOTICE

1. The magnetic field strength (Gauss) required to cause the switch to change state (operate and release) will be as specified in the magnetic characteristics. To test the switch against the specified magnetic characteristics, the switch must be placed in a uniform magnetic field.

9 Application Information

9.1 Typical Application

It is recommended that an external capacitor C_{bypass} is connected to the supply. This can reduce the noise injected into the device. Normal 0.1 μF is suggested.

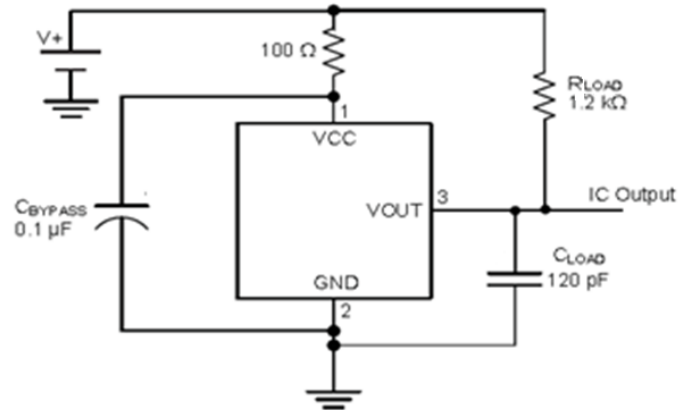

Typical Application Circuit

When $\text{mode}=0$, the Output Polarity bit is not set ($\text{POL} = 0$), the CH481 output switches on after the magnetic field at the Hall sensor IC exceeds the operate point threshold, BOP. When the magnetic field is reduced to below the release point threshold, BRP, the device output switches off. The difference between the magnetic operate and release points is called the hysteresis of the device, BHYS. In the alternative case, in which the Output Polarity bit is set ($\text{POL} = 1$), CH481 response to magnetic pole is alternative; the CH481 output switches off when the magnetic field at the Hall sensor IC exceeds the operate point threshold, BRP. When the magnetic field is reduced to below the release point threshold, BOP, the device output switches on.

When $\text{mode}=0$, $\text{BOPPOL}=1$, the device is configured as invert unipolar switch. The output of states depends on POL, if $\text{POL}=0$, the device turns off when field is lower than Bop, turns on when higher than Brp; if $\text{POL}=1$, the device turns off when field is lower than Brp, turns on when field lower than Bop.

Note that for the Pre-Programming BOP Target, BOPinit, when $\text{BOPPOL} = 0$ although the operating range is 0 to B+, the initial BOPinit is actually negative, and likewise, when $\text{BOPPOL} = 1$, although the operating range 0 to B-, the initial BOPinit is actually positive.

If the $\text{mode}=1$, the device is configured as latch, in this case, the $\text{Bop}=-\text{Brp}$, if the field is higher than Bop, the device is turned on. The device is turned off when the field is lower than Brp. At this case, BOPPOL is ineffective.

9.2 Device Output

If the device is powered on with a magnetic field strength between BRP and BOP, then the device output is indeterminate and can either be Hi-Z or Low. If the field strength is greater than BOP, then the output is pulled low. If the field strength is less than BRP, then the output is released.

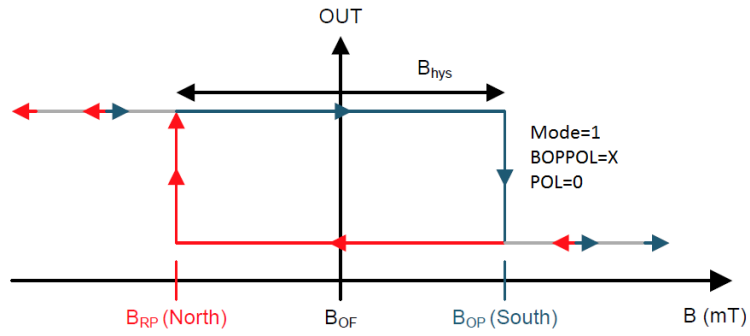

Latch: output voltage characteristic (Mode=1, BOPPOL=X, POL=0)

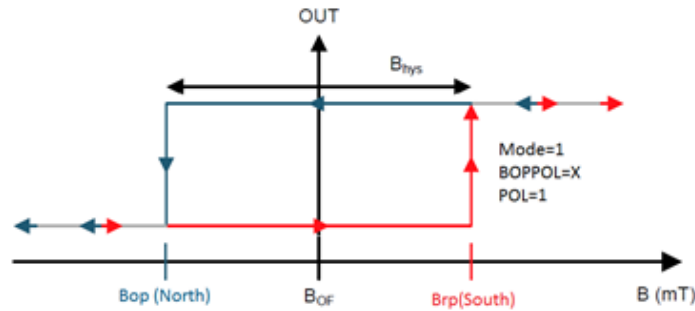

Latch: output voltage characteristic (Mode=1, BOPPOL=X, POL=1)

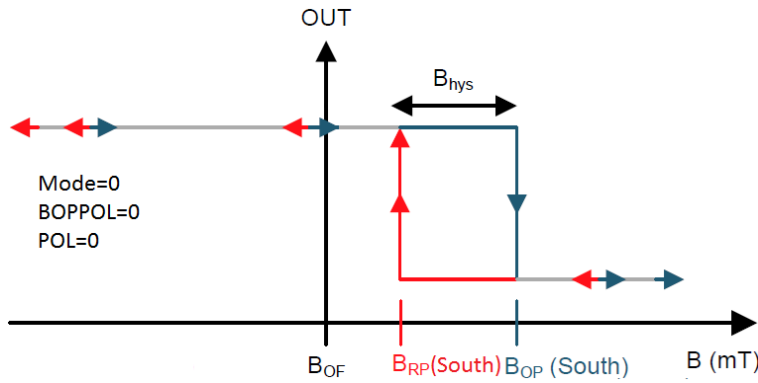

Unipolar: output voltage characteristic (Mode=0, BOPPOL=0, POL=0)

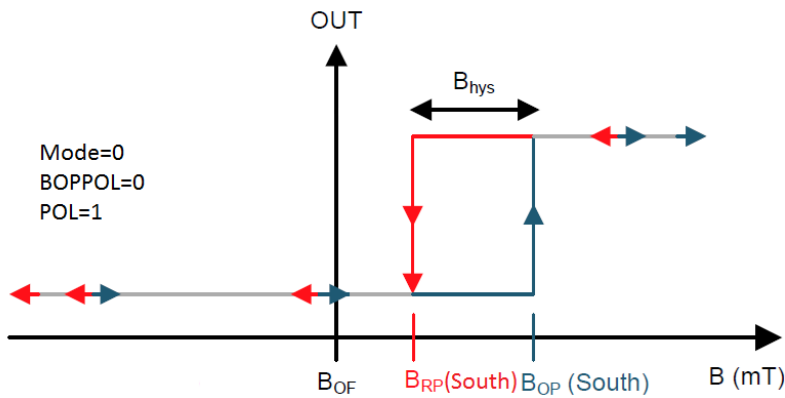

Unipolar: output voltage characteristic (Mode=0, BOPPOL=0, POL=1)

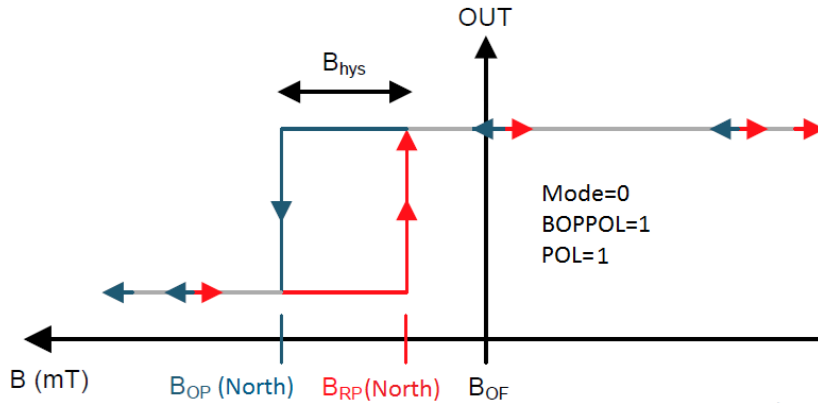

Unipolar: output voltage characteristic (Mode=0, BOPPOL=1, POL=1)

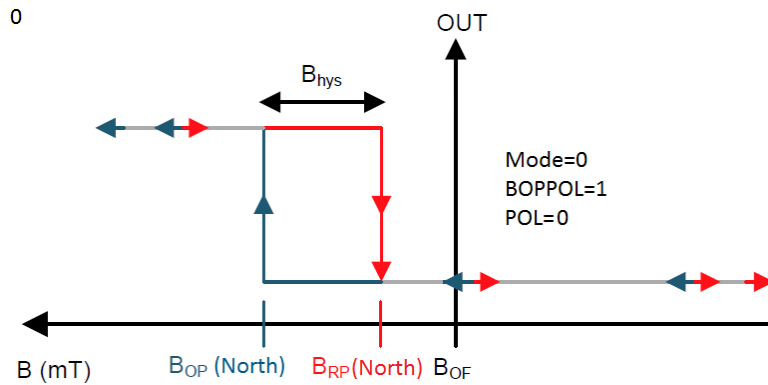

Unipolar: output voltage characteristic (Mode=0, BOPPOL=1, POL=0)

9.3 Output Stage

The CH481 output stage uses an open-drain NMOS, and it is rated to sink up to 30 mA of current. For proper operation, calculate the value of the pullup resistor R1 using Equation 1.

$$\frac{V_{ref\ max}}{30\ mA} \leq R1 \leq \frac{V_{ref\ min}}{100\ \mu A} \quad (1)$$

The size of R1 is a tradeoff between the OUT rise time and the current when OUT is pulled low. A lower current is generally better, however faster transitions and bandwidth require a smaller resistor for faster switching. In addition, ensure that the value of R1 > 500 Ω to ensure the output driver can pull the OUT pin close to GND.

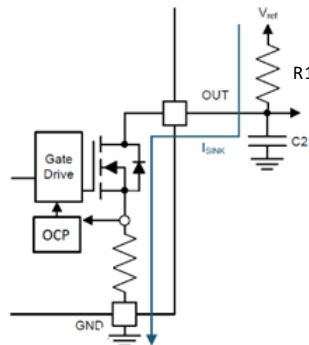

Select a value for C2 based on the system bandwidth specifications as shown in Equation 2.

$$2 \times f_{BW} \text{ (Hz)} < \frac{1}{2\pi \times R1 \times C2} \quad (2)$$

Most applications do not require this C2 filtering capacitor.

9.4 Protection Circuits

The CH481 device is fully protected against overcurrent and reverse-supply conditions.

9.5 Overcurrent Protection (OCP)

An analog current-limit circuit limits the current through the FET. The driver current is clamped to IOCP. During this clamping, the rDS(on) of the output FET is increased from the nominal value.

9.6 Reverse Supply Protection

The CH481 device is protected in the event that the VCC pin and the GND pin are reversed (up to -24 V).

9.7 Alternative Two-Wire Application

For systems that require minimal wire count, the device output can be connected to VCC through a resistor, and the total supplied current can be sensed near the controller.

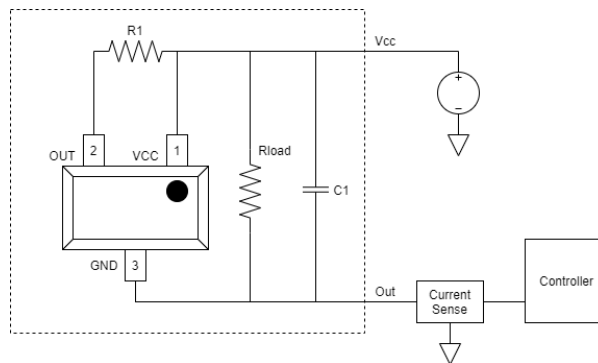

2-Wire Application

Current can be sensed using a shunt resistor or other circuitry.

For typical usage, when R1 = 510Ohm, Rload = NC (not connected), C1 = 0.1uF we can get the current sensing as below table:
(Vcc = 12V).

| Hall Status | Min | Typ | Max | Unit |
|-------------|-----|-----|-----|------|
| Output High | 1 | - | 4 | mA |
| Output Low | 24 | - | 28 | mA |

Customer can tune Rload to change the base current in order to fit different system.

10 Package Information:

Package Designator TO-92S

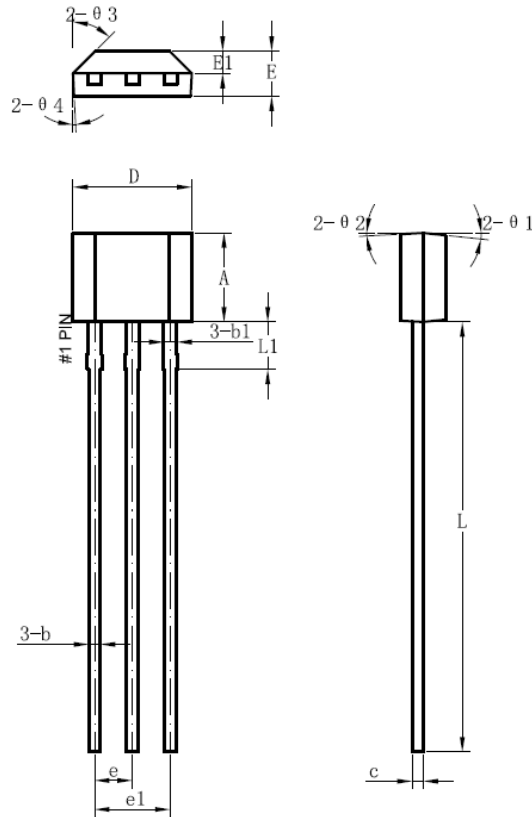

| Symbol | Dimensions in Millimeters | | |
|------------|---------------------------|------|------|
| | Min. | Typ. | Max. |
| A | 2.9 | 3 | 3.1 |
| b | 0.35 | 0.39 | 0.56 |
| b1 | | 0.44 | |
| c | 0.36 | 0.38 | 0.51 |
| D | 3.9 | 4 | 4.1 |
| E | 1.42 | 1.52 | 1.62 |
| E1 | | 0.75 | |
| e | | 1.27 | |
| e1 | | 2.54 | |
| L | 13.5 | 14.5 | 15.5 |
| L1 | | 1.6 | |
| $\theta 1$ | | 6° | |
| $\theta 2$ | | 3° | |
| $\theta 3$ | | 45° | |

PACKAGE DESIGNATOR
SOT-23-3L

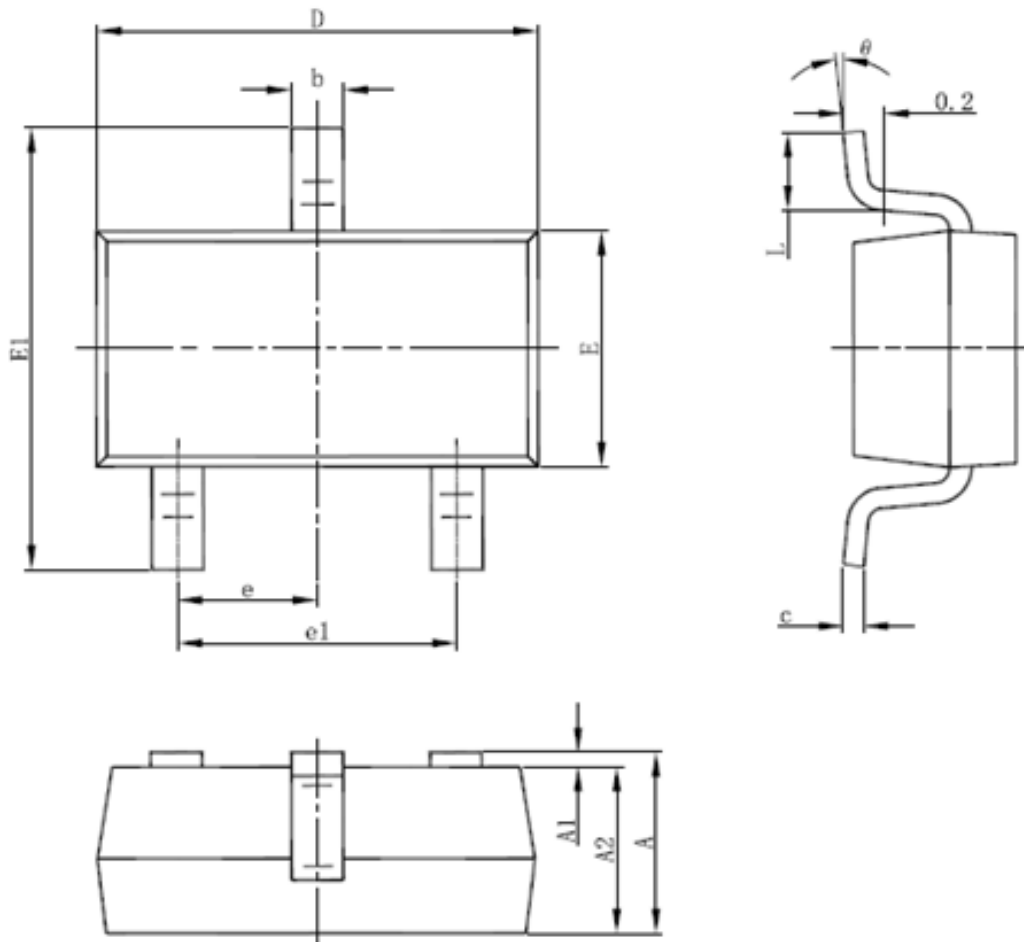

| Symbol | Dimensions In Millimeters | | Dimensions In Inches | |
|----------|---------------------------|-------|----------------------|-------|
| | Min | Max | Min | Max |
| A | 1.050 | 1.250 | 0.041 | 0.049 |
| A1 | 0.000 | 0.100 | 0.000 | 0.004 |
| A2 | 1.050 | 1.150 | 0.041 | 0.045 |
| b | 0.300 | 0.500 | 0.012 | 0.020 |
| c | 0.100 | 0.200 | 0.004 | 0.008 |
| D | 2.820 | 3.020 | 0.111 | 0.119 |
| E | 1.500 | 1.700 | 0.059 | 0.067 |
| E1 | 2.650 | 2.950 | 0.104 | 0.116 |
| e | 0.950(BSC) | | 0.037(BSC) | |
| e1 | 1.800 | 2.000 | 0.071 | 0.079 |
| L | 0.300 | 0.600 | 0.012 | 0.024 |
| θ | 0° | 8° | 0° | 8° |

PACKAGE DESIGNATOR
SOT-89-3L

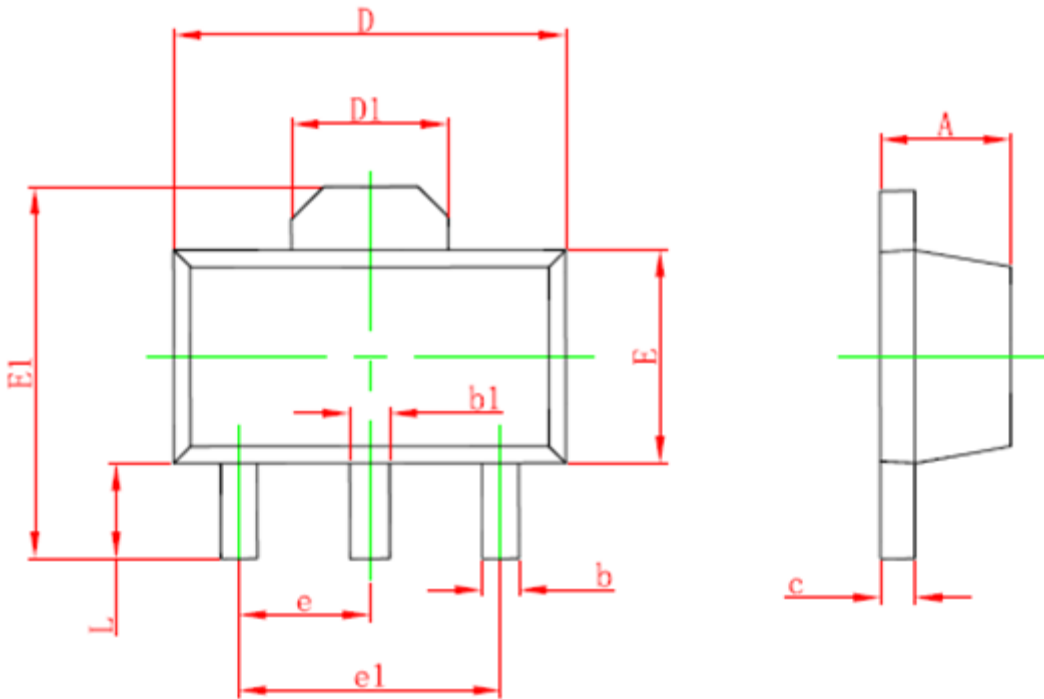

| Symbol | Dimensions In Millimeters | | Dimensions In Inches | |
|--------|---------------------------|-------|----------------------|-------|
| | Min. | Max. | Min. | Max. |
| A | 1.400 | 1.600 | 0.055 | 0.063 |
| b | 0.320 | 0.520 | 0.013 | 0.020 |
| b1 | 0.400 | 0.580 | 0.016 | 0.023 |
| c | 0.350 | 0.440 | 0.014 | 0.017 |
| D | 4.400 | 4.600 | 0.173 | 0.181 |
| D1 | 1.550 REF. | | 0.061 REF. | |
| E | 2.300 | 2.600 | 0.091 | 0.102 |
| E1 | 3.940 | 4.250 | 0.155 | 0.167 |
| e | 1.500 TYP. | | 0.060 TYP. | |
| e1 | 3.000 TYP. | | 0.118 TYP. | |
| L | 0.900 | 1.200 | 0.035 | 0.047 |

This is advanced information on a new product now in development or undergoing evaluation. Details are subject to change without notice and Cosemitech assumes no obligation for future manufacture of this product. Contact Cosemitech for the latest status.

Information furnished is believed to be accurate and reliable. However, Cosemitech assumes no responsibility for the consequences of use of such information nor for any infringement of patents or other rights of third parties which may result from its use. No license is granted by implication or otherwise under any patent or patent rights of Cosemitech. Specification mentioned in this publication are subject to change without notice. This publication supersedes and replaces all information previously supplied. Cosemitech products are not authorized for use as critical components in life support devices or systems without express written approval of Cosemitech.

The Cosemitech logo is a registered trademark of Cosemitech.