

## TPS256x 双通道精度可调节限流电源开关

### 1 特性

- 2 个独立的电流限制通道
- 满足 USB 限流要求
- 可调节电流限制：250mA 至 2.8A (典型值)
- 2.8A 电流下的限流精度为  $\pm 7.5\%$
- 快速过流响应：3.5  $\mu\text{s}$  (典型值)
- 2 个 44m $\Omega$  高侧 MOSFET
- 工作电压范围：2.5V 至 6.5V
- 最大待机电源电流 2  $\mu\text{A}$
- 内置软启动
- 15kV、8kV 系统级 ESD 能力
- UL 列表：文件号 E169910
- 获得 CB 和 Nemko 认证

### 2 应用

- USB 端口、集线器
- 数字电视
- 机顶盒
- VoIP 电话

### 3 说明

TPS2560 和 TPS2561 (TPS256x) 是双通道配电开关，用于需要精准电流限制或者会遇到高容性负载和短路的应用。这些器件通过一个外部电阻器为每个通道提供 250mA 至 2.8A (典型值) 之间的可编程电流限制阈值。通过控制电源开关的上升时间和下降时间，可最大程度地降低开通和关断期间的电流浪涌。

当输出负载超过电流限制阈值时，通过切换至恒定电流模式，TPS256x 器件的每个通道均可将输出电流限制在安全水平。在过流和过热条件下，每个通道的 FAULTx 逻辑输出单独置位为低电平。

#### 器件信息(1)

器件型号	封装	封装尺寸 (标称值)
TPS2560、TPS2561	VSON (10)	3.00mm × 3.00mm

(1) 如需了解所有可用封装，请参阅数据表末尾的可订购产品附录。

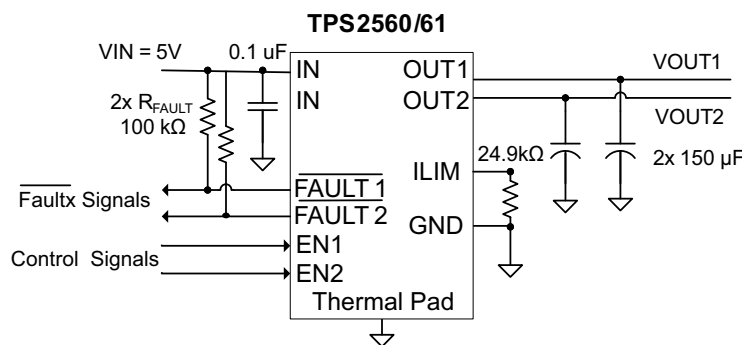

典型应用图



## Table of Contents

<b>1 特性</b> .....	1	9.2 Functional Block Diagram.....	10
<b>2 应用</b> .....	1	9.3 Feature Description.....	10
<b>3 说明</b> .....	1	9.4 Device Functional Modes.....	11
<b>4 Revision History</b> .....	2	<b>10 Power Supply Recommendations</b> .....	18
<b>5 Device Comparison Table</b> .....	3	10.1 Self-Powered and Bus-Powered Hubs.....	18
<b>6 Pin Configuration and Functions</b> .....	3	10.2 Low-Power Bus-Powered and High-Power Bus-Powered Functions.....	18
<b>7 Specifications</b> .....	4	<b>11 Layout</b> .....	19
7.1 Absolute Maximum Ratings.....	4	11.1 Layout Guidelines.....	19
7.2 ESD Ratings.....	4	11.2 Layout Example.....	20
7.3 ESD Ratings: Surge.....	4	<b>12 Device and Documentation Support</b> .....	21
7.4 Recommended Operating Conditions.....	4	12.1 接收文档更新通知.....	21
7.5 Thermal Information.....	5	12.2 支持资源.....	21
7.6 Electrical Characteristics.....	5	12.3 Trademarks.....	21
7.7 Dissipation Ratings.....	6	12.4 静电放电警告.....	21
7.8 Typical Characteristics.....	7	12.5 术语表.....	21
<b>8 Parameter Measurement Information</b> .....	9	<b>13 Mechanical, Packaging, and Orderable Information</b> .....	21
<b>9 Detailed Description</b> .....	10		
9.1 Overview.....	10		

## 4 Revision History

注：以前版本的页码可能与当前版本的页码不同

Changes from Revision B (December 2015) to Revision C (October 2020)	Page
• 更新了整个文档中的表格、图和交叉参考的编号格式.....	1
• Added OUTx parameter to <i>Absolute Maximum Ratings</i> table .....	4

Changes from Revision A (February 2012) to Revision B (December 2015)	Page
• 添加了 ESD 等级表、特性说明部分、器件功能模式、应用和实施部分、电源相关建议部分、布局部分、器件和文档支持部分以及机械、封装和可订购信息部分.....	1

Changes from Revision * (December 2009) to Revision A (February 2012)	Page
• Changed $V_{ENx}$ to $V_{EN\bar{x}}$ in Recommended Operating Conditions.....	4
• Changed $V_{EN\bar{x}}$ to $V_{ENx}$ in Recommended Operating Conditions.....	4

## 5 Device Comparison Table

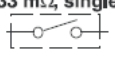
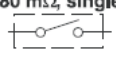
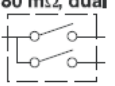
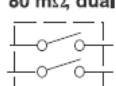
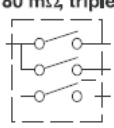
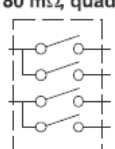
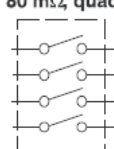
GENERAL SWITCH CATALOG						
 TPS201xA 0.2 A - 2 A TPS202x 0.2 A - 2 A TPS203x 0.2 A - 2 A	 TPS2014 600 mA TPS2015 1 A TPS2041B 500 mA TPS2051B 500 mA TPS2045A 250 mA TPS2049 100 mA TPS2055A 250 mA TPS2061 1 A TPS2065 1 A TPS2068 1.5 A TPS2069 1.5 A	 TPS2042B 500 mA TPS2052B 500 mA TPS2046B 250 mA TPS2056 250 mA TPS2062 1 A TPS2066 1 A TPS2060 1.5 A TPS2064 1.5 A	 TPS2080 500 mA TPS2081 500 mA TPS2082 500 mA TPS2090 250 mA TPS2091 250 mA TPS2092 250 mA	 TPS2043B 500 mA TPS2053B 500 mA TPS2047B 250 mA TPS2057A 250 mA TPS2063 1 A TPS2067 1 A	 TPS2044B 500 mA TPS2054B 500 mA TPS2048A 250 mA TPS2058 250 mA	 TPS2085 500 mA TPS2086 500 mA TPS2087 500 mA TPS2095 250 mA TPS2096 250 mA TPS2097 250 mA

## 6 Pin Configuration and Functions

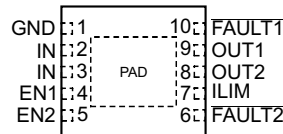

DRC Package, 10-Pin VSON, Top View

表 6-1. Pin Functions

NAME	PIN		I/O	DESCRIPTION
	TPS2560	TPS2561		
EN1	4	—	I	Enable input, logic low turns on channel one power switch.
EN1	—	4	I	Enable input, logic high turns on channel one power switch.
EN2	5	—	I	Enable input, logic low turns on channel two power switch.
EN2	—	5	I	Enable input, logic high turns on channel two power switch.
GND	1	1	—	Ground connection; connect externally to the thermal pad.
IN	2, 3	2, 3	I	Input voltage; connect a 0.1 $\mu$ F or greater ceramic capacitor from IN to GND as close to the IC as possible.
FAULT1	10	10	O	Active-low open-drain output, asserted during overcurrent or overtemperature condition on channel one.
FAULT2	6	6	O	Active-low open-drain output, asserted during overcurrent or overtemperature condition on channel two.
OUT1	9	9	O	Power-switch output for channel one.
OUT2	8	8	O	Power-switch output for channel two.
ILIM	7	7	O	External resistor used to set current-limit threshold; recommended $20 \text{ k}\Omega \leq R_{\text{ILIM}} \leq 187 \text{ k}\Omega$ .
Thermal pad	PAD	PAD	—	Internally connected to GND; used to heat-sink the part to the circuit board traces. Connect the thermal pad to GND pin externally.

## 7 Specifications

### 7.1 Absolute Maximum Ratings

over operating free-air temperature range (unless otherwise noted)<sup>(1) (2)</sup>

	MIN	MAX	UNIT
Voltage on IN, ENx or $\overline{\text{ENx}}$ , ILIM, $\overline{\text{FAULTx}}$	- 0.3	7	V
OUTx	- 0.8	7	V
Voltage from IN to OUTx	- 7	7	V
Continuous output current	Internally limited		-
Continuous total power dissipation	See <a href="#">Dissipation Ratings</a>		-
Continuous $\overline{\text{FAULTx}}$ sink current	25		mA
ILIM source current	Internally limited		-
T <sub>J</sub> Maximum junction temperature	- 40	OTSD <sup>(3)</sup>	°C

(1) Stresses beyond those listed under *Absolute Maximum Ratings* may cause permanent damage to the device. These are stress ratings only, which do not imply functional operation of the device at these or any other conditions beyond those indicated under the [Recommended Operating Conditions](#). Exposure to absolute-maximum-rated conditions for extended periods may affect device reliability.

(2) Voltages are referenced to GND unless otherwise noted.

(3) Ambient over temperature shutdown threshold.

### 7.2 ESD Ratings

		VALUE	UNIT
V <sub>(ESD)</sub>	Electrostatic discharge	Human-body model (HBM), per ANSI/ESDA/JEDEC JS-001 <sup>(1)</sup>	±2000
		Charged-device model (CDM), per JEDEC specification JESD22-C101 <sup>(2)</sup>	±500

(1) JEDEC document JEP155 states that 500-V HBM allows safe manufacturing with a standard ESD control process.

(2) JEDEC document JEP157 states that 250-V CDM allows safe manufacturing with a standard ESD control process.

### 7.3 ESD Ratings: Surge

		VALUE	UNIT
V <sub>(ESD)</sub>	Electrostatic discharge	IEC 61000-4-2 contact discharge <sup>(1)</sup>	±8000
		IEC 61000-4-2 air-gap discharge <sup>(1)</sup>	±15000

(1) Surges per EN61000-4-2: 1999 applied to output terminals of EVM. These are passing test levels, not failure threshold.

### 7.4 Recommended Operating Conditions

over operating free-air temperature range (unless otherwise noted)

		MIN	NOM	MAX	UNIT
V <sub>IN</sub>	Input voltage	2.5		6.5	V
V <sub>ENx</sub>	TPS2560 enable voltage	0		6.5	V
V <sub>ENx</sub>	TPS2561 enable voltage	0		6.5	V
V <sub>IH</sub>	High-level input voltage on ENx or $\overline{\text{ENx}}$	1.1			V
V <sub>IL</sub>	Low-level input voltage on ENx or $\overline{\text{ENx}}$			0.66	V
I <sub>OUTx</sub>	Continuous output current per channel	0		2.5	A
	Continuous $\overline{\text{FAULTx}}$ sink current	0		10	mA
R <sub>ILIM</sub>	Recommended resistor limit	20		187	kΩ
T <sub>J</sub>	Operating junction temperature	- 40		125	°C

## 7.5 Thermal Information

THERMAL METRIC <sup>(1)</sup>		TPS256x	UNIT
		DRC (VSON)	
		10 PINS	
R <sub>θJA</sub>	Junction-to-ambient thermal resistance	47.8	°C/W
R <sub>θJC(top)</sub>	Junction-to-case (top) thermal resistance	66.2	°C/W
R <sub>θJB</sub>	Junction-to-board thermal resistance	22.4	°C/W
ψ <sub>JT</sub>	Junction-to-top characterization parameter	1.6	°C/W
ψ <sub>JB</sub>	Junction-to-board characterization parameter	22.6	°C/W
R <sub>θJC(bot)</sub>	Junction-to-case (bottom) thermal resistance	4.9	°C/W

(1) For more information about traditional and new thermal metrics, see the [Semiconductor and IC Package Thermal Metrics application report](#).

## 7.6 Electrical Characteristics

over recommended operating conditions, V<sub>ENx</sub> = 0 V, or V<sub>ENx</sub> = V<sub>IN</sub> (unless otherwise noted)

PARAMETER		TEST CONDITIONS <sup>(1)</sup>	MIN	TYP	MAX	UNIT	
<b>POWER SWITCH</b>							
r <sub>DS(on)</sub>	Static drain-source on-state resistance per channel, IN to OUTx	T <sub>J</sub> = 25 °C	44	50		mΩ	
		- 40 °C ≤ T <sub>J</sub> ≤ 125 °C			70		
t <sub>r</sub>	Rise time, output	C <sub>Lx</sub> = 1 μF, R <sub>Lx</sub> = 100 Ω (see 图 8-1)	V <sub>IN</sub> = 6.5 V	2	3	4	ms
			V <sub>IN</sub> = 2.5 V	1	2	3	
t <sub>f</sub>	Fall time, output	C <sub>Lx</sub> = 1 μF, R <sub>Lx</sub> = 100 Ω (see 图 8-1)	V <sub>IN</sub> = 6.5 V	0.6	0.8	1.0	ms
			V <sub>IN</sub> = 2.5 V	0.4	0.6	0.8	
<b>ENABLE INPUT, EN OR EN</b>							
	Enable pin turn on/off threshold		0.66		1.1	V	
	Hysteresis			55 <sup>(2)</sup>		mV	
I <sub>EN</sub>	Input current	V <sub>ENx</sub> = 0 V or 6.5 V, V <sub>ENx</sub> = 0 V or 6.5 V	- 0.5		0.5	μA	
t <sub>on</sub>	Turnon time	C <sub>Lx</sub> = 1 μF, R <sub>Lx</sub> = 100 Ω, (see 图 8-1)			9	ms	
t <sub>off</sub>	Turnoff time				6	ms	
<b>CURRENT LIMIT</b>							
I <sub>OS</sub>	Current-limit threshold per channel (Maximum DC output current I <sub>OUTx</sub> delivered to load) and Short-circuit current, OUTx connected to GND	R <sub>LIM</sub> = 20 kΩ	2590	2800	3005	mA	
		R <sub>LIM</sub> = 61.9 kΩ	800	900	1005		
		R <sub>LIM</sub> = 100 kΩ	470	560	645		
t <sub>IOS</sub>	Response time to short circuit	V <sub>IN</sub> = 5.0 V, (see 图 8-2)		3.5 <sup>(2)</sup>		μs	

## 7.6 Electrical Characteristics (continued)

over recommended operating conditions,  $V_{/ENx} = 0\text{ V}$ , or  $V_{ENx} = V_{IN}$  (unless otherwise noted)

PARAMETER		TEST CONDITIONS <sup>(1)</sup>	MIN	TYP	MAX	UNIT
<b>SUPPLY CURRENT</b>						
$I_{IN\_off}$	Supply current, low-level output	$V_{IN} = 6.5\text{ V}$ , no load on OUTx, $V_{ENx} = 6.5\text{ V}$ or $V_{ENx} = 0\text{ V}$		0.1	2.0	$\mu\text{ A}$
$I_{IN\_on}$	Supply current, high-level output	$V_{IN} = 6.5\text{ V}$ , no load on OUT	$R_{ILIM} = 20\text{ k}\Omega$	100	125	$\mu\text{ A}$
			$R_{ILIM} = 100\text{ k}\Omega$	85	110	$\mu\text{ A}$
$I_{REV}$	Reverse leakage current	$V_{OUTx} = 6.5\text{ V}$ , $V_{IN} = 0\text{ V}$		0.01	1.0	$\mu\text{ A}$
<b>UNDERVOLTAGE LOCKOUT</b>						
UVLO	Low-level input voltage, IN	$V_{IN}$ rising		2.35	2.45	V
	Hysteresis, IN	$T_J = 25^\circ\text{C}$		35		mV
<b>FAULTx FLAG</b>						
$V_{OL}$	Output low voltage, FAULTx	$I_{FAULTx} = 1\text{ mA}$			180	mV
	Off-state leakage	$V_{FAULTx} = 6.5\text{ V}$			1	$\mu\text{ A}$
	FAULTx deglitch	FAULTx assertion or de-assertion due to overcurrent condition	6	9	13	ms
<b>THERMAL SHUTDOWN</b>						
OTSD2	Thermal shutdown threshold		155			$^\circ\text{C}$
OTSD	Thermal shutdown threshold in current-limit		135			$^\circ\text{C}$
	Hysteresis			20 <sup>(2)</sup>		$^\circ\text{C}$

- (1) Pulse-testing techniques maintain junction temperature close to ambient temperature; thermal effects must be taken into account separately.
- (2) These parameters are provided for reference only, and do not constitute part of TI's published specifications for purposes of TI's product warranty.

## 7.7 Dissipation Ratings

BOARD	PACKAGE	THERMAL RESISTANCE <sup>(2)</sup> $R_{\theta JA}$	THERMAL RESISTANCE $R_{\theta JC}$	$T_A \leq 25^\circ\text{C}$ POWER RATING
High-K <sup>(1)</sup>	DRC	41.6 $^\circ\text{C}/\text{W}$	10.7 $^\circ\text{C}/\text{W}$	2403 mW

- (1) The JEDEC high-K (2s2p) board used to derive this data was a 3-in  $\times$  3-in, multilayer board with 1-ounce internal power and ground planes and 2-ounce copper traces on top and bottom of the board.
- (2) Mounting per the [PowerPAD™ Thermally Enhanced Package application report](#).

### 7.8 Typical Characteristics



图 7-1. Turn-On Delay and Rise Time



图 7-2. Turn-Off Delay and Fall Time

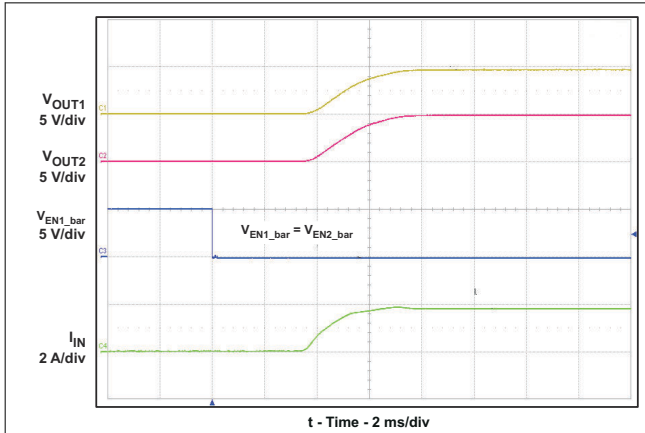

图 7-3. Full-Load to Short-Circuit Transient Response

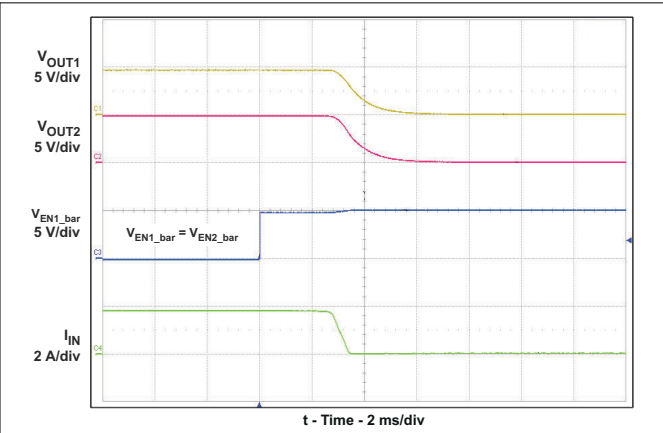

图 7-4. Short-Circuit to Full-Load Recovery Response

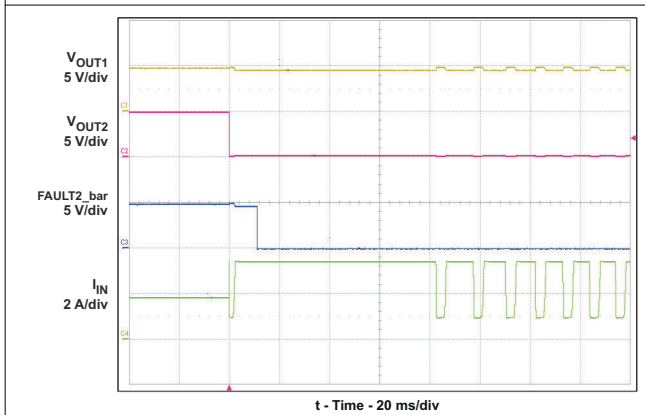

图 7-5. UVLO - Undervoltage Lockout - V

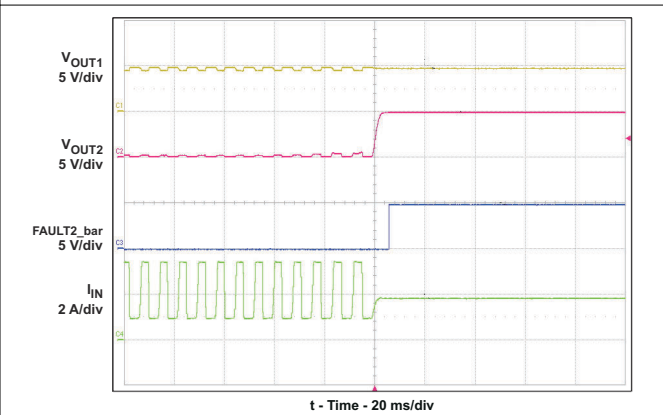

图 7-6.  $I_{IN}$  - Supply Current, Output Disabled - nA

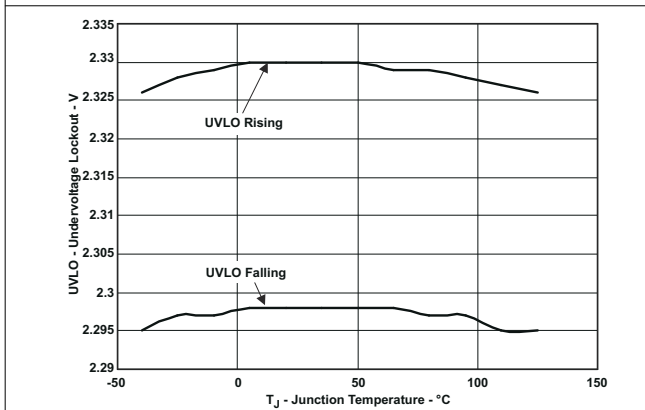

图 7-7.  $I_{IN}$  - Supply Current, Output Enabled -  $\mu A$

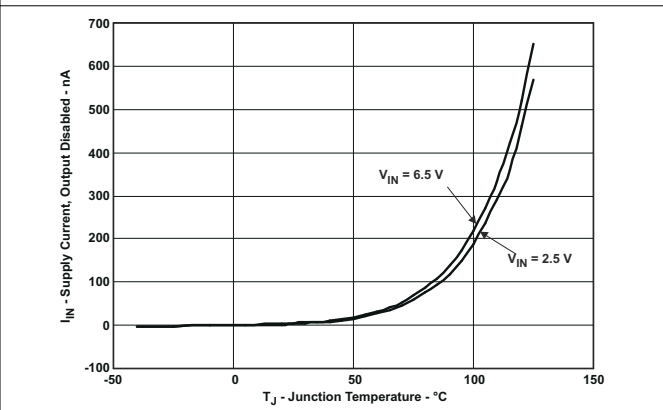

图 7-8.  $I_{IN}$  - Supply Current, Output Enabled -  $\mu A$

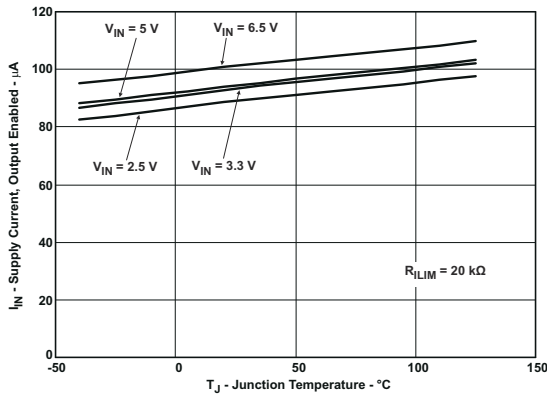

图 7-9. MOSFET  $r_{DS(on)}$  vs Junction Temperature

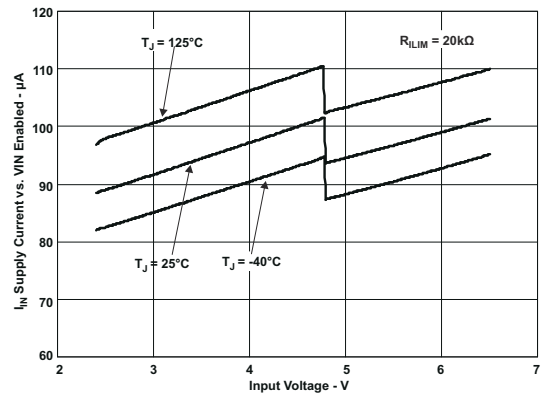

图 7-10. Switch Current vs Drain-Source Voltage Across Switch

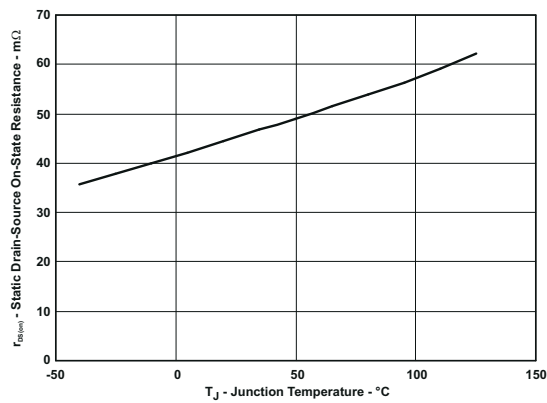

图 7-11. Switch Current vs Drain-Source Voltage Across Switch

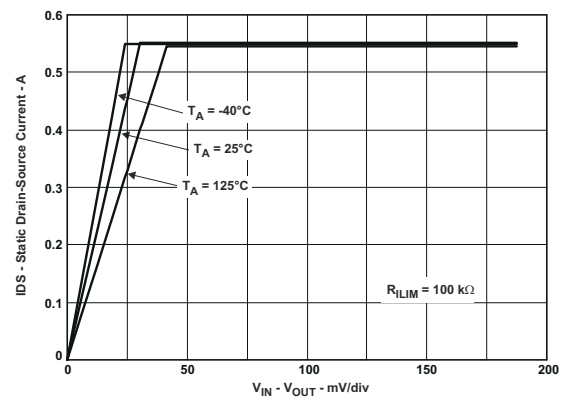

## 8 Parameter Measurement Information

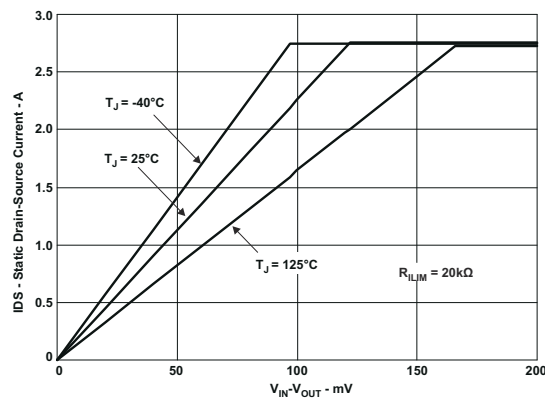

图 8-1. Test Circuit and Voltage Waveforms



图 8-2. Response Time to Short Circuit Waveform

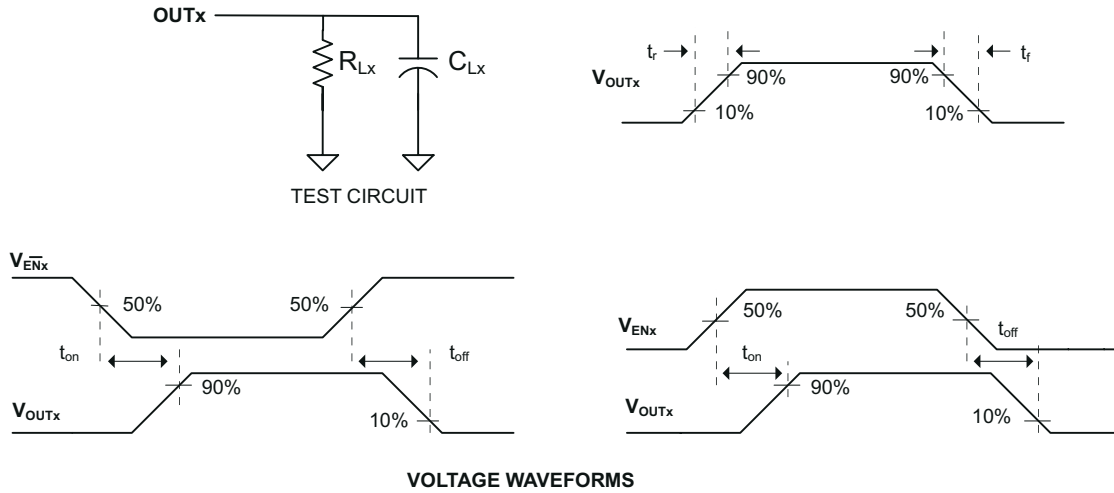

图 8-3. Output Voltage vs Current-Limit Threshold

## 9 Detailed Description

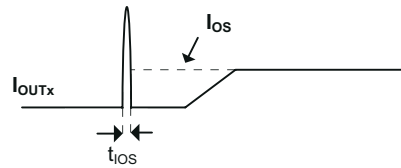
### 9.1 Overview

The TPS256x is a dual-channel, current-limited power-distribution switch using N-channel MOSFETs for applications where short circuits or heavy capacitive loads will be encountered. This device allows the user to program the current-limit threshold between 250 mA and 2.8 A (typ) per channel via an external resistor. This device incorporates an internal charge pump and gate drive circuitry necessary to drive the N-channel MOSFETs. The charge pump supplies power to the driver circuit for each channel and provides the necessary voltage to pull the gate of the MOSFET above the source. The charge pump operates from input voltages as low as 2.5 V and requires little supply current. The driver controls the gate voltage of the power switch. The driver incorporates circuitry that controls the rise and fall times of the output voltage to limit large current and voltage surges and provides built-in soft-start functionality. Each channel of the TPS256x limits the output current to the programmed current-limit threshold  $I_{OS}$  during an overcurrent or short-circuit event by reducing the charge pump voltage driving the N-channel MOSFET and operating it in the linear range of operation. The result of limiting the output current to  $I_{OS}$  reduces the output voltage at OUTx because the N-channel MOSFET is no longer fully enhanced.

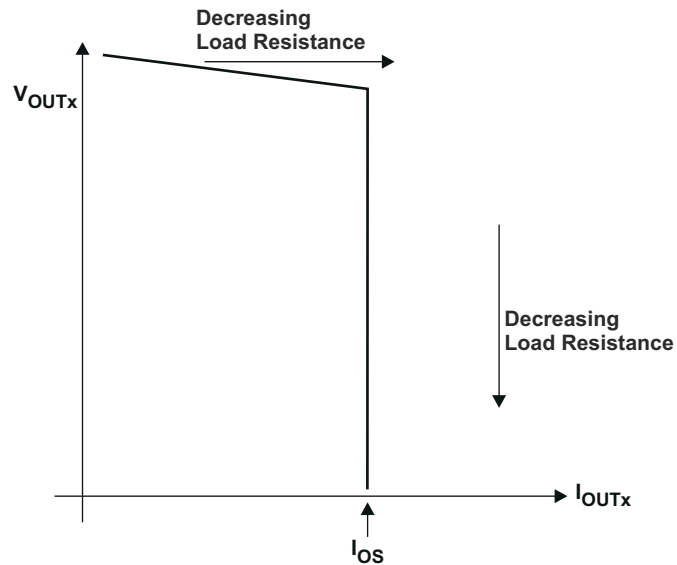
### 9.2 Functional Block Diagram

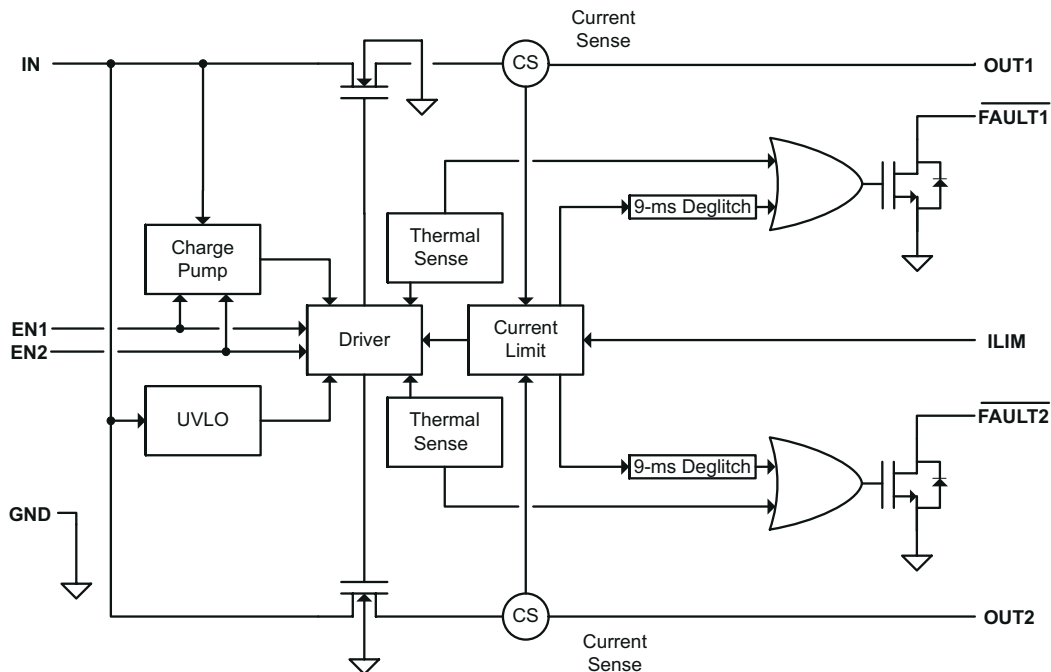

### 9.3 Feature Description

#### 9.3.1 Overcurrent Conditions

The TPS256x responds to overcurrent conditions by limiting the output current per channel to  $I_{OS}$ . When an overcurrent condition is detected, the device maintains a constant output current and reduces the output voltage accordingly. Two possible overload conditions can occur.

The first condition is when a short circuit or partial short circuit is present when the device is powered-up or enabled. The output voltage is held near zero potential with respect to ground and the TPS256x ramps the output current to  $I_{OS}$ . The TPS256x devices will limit the current to  $I_{OS}$  until the overload condition is removed or the device begins to thermal cycle.

The second condition is when a short circuit, partial short circuit, or transient overload occurs while the device is enabled and powered on. The device responds to the overcurrent condition within time  $t_{IOS}$  (see [Figure 8-2](#)). The current-sense amplifier is overdriven during this time and momentarily disables the internal current-limit MOSFET. The current-sense amplifier recovers and ramps the output current to  $I_{OS}$ . Similar to the previous

case, the TPS256x will limit the current to  $I_{OS}$  until the overload condition is removed or the device begins to thermal cycle.

The TPS256x thermal cycles if an overload condition is present long enough to activate thermal limiting in any of the above cases. The device turns off when the junction temperature exceeds 135°C (min) while in current limit. The device remains off until the junction temperature cools 20°C (typ) and then restarts. The TPS256x cycles on/off until the overload is removed (see [Figure 7-4](#)).

### 9.3.2 FAULT $\bar{x}$ Response

The FAULT $\bar{x}$  open-drain outputs are asserted (active low) on an individual channel during an overcurrent or overtemperature condition. The TPS256x asserts the FAULT $\bar{x}$  signal until the fault condition is removed and the device resumes normal operation on that channel. The TPS256x is designed to eliminate false FAULT $\bar{x}$  reporting by using an internal delay "deglitch" circuit (9-ms typ) for overcurrent conditions without the need for external circuitry. This ensures that FAULT $\bar{x}$  is not accidentally asserted due to normal operation such as starting into a heavy capacitive load. The deglitch circuitry delays entering and leaving current-limited induced fault conditions. The FAULT $\bar{x}$  signal is not deglitched when the MOSFET is disabled due to an overtemperature condition but is deglitched after the device has cooled and begins to turn on. This unidirectional deglitch prevents FAULT $\bar{x}$  oscillation during an overtemperature event.

### 9.3.3 Undervoltage Lockout (UVLO)

The undervoltage lockout (UVLO) circuit disables the power switch until the input voltage reaches the UVLO turn-on threshold. Built-in hysteresis prevents unwanted on/off cycling due to input voltage droop during turn on.

### 9.3.4 Enable ( $\bar{ENx}$ or ENx)

The logic enables control the power switches and device supply current. The supply current is reduced to less than 2-  $\mu$  A when a logic high is present on  $\bar{ENx}$  or when a logic low is present on ENx. A logic low input on  $\bar{ENx}$  or a logic high input on ENx enables the driver, control circuits, and power switches. The enable inputs are compatible with both TTL and CMOS logic levels.

### 9.3.5 Thermal Sense

The TPS256x self protects by using two independent thermal sensing circuits that monitor the operating temperature of the power switch and disable operation if the temperature exceeds recommended operating conditions. Each channel of the TPS256x operates in constant-current mode during an overcurrent conditions, which increases the voltage drop across the power switch. The power dissipation in the package is proportional to the voltage drop across the power switch, which increases the junction temperature during an overcurrent condition. The first thermal sensor (OTSD) turns off the individual power switch channel when the die temperature exceeds 135°C (min) and the channel is in current limit. Hysteresis is built into the thermal sensor, and the switch turns on after the device has cooled approximately 20°C.

The TPS256x also has a second ambient thermal sensor (OTSD2). The ambient thermal sensor turns off both power switch channels when the die temperature exceeds 155°C (min) regardless of whether the power switch channels are in current limit and will turn on the power switches after the device has cooled approximately 20°C. The TPS256x continues to cycle off and on until the fault is removed.

## 9.4 Device Functional Modes

There are no other functional modes.

## Application and Implementation

### Note

Information in the following applications sections is not part of the TI component specification, and TI does not warrant its accuracy or completeness. TI's customers are responsible for determining suitability of components for their purposes. Customers should validate and test their design implementation to confirm system functionality.

## 10.1 Application Information

### 10.1.1 Auto-Retry Functionality

Some applications require that an overcurrent condition disables the part momentarily during a fault condition and re-enables after a pre-set time. This auto-retry functionality can be implemented with an external resistor and capacitor. During a fault condition, FAULT $\bar{x}$  pulls EN $x$  low disabling the part. The part is disabled when EN $x$  is pulled below the turn-off threshold, and FAULT $\bar{x}$  goes high impedance allowing C<sub>RETRY</sub> to begin charging. The part re-enables when the voltage on EN $x$  reaches the turn-on threshold, and the auto-retry time is determined by the resistor/capacitor time constant. The part will continue to cycle in this manner until the fault condition is removed.



图 10-1. Auto-Retry Functionality

Some applications require auto-retry functionality and the ability to enable/disable with an external logic signal. The figure below shows how an external logic signal can drive EN through R<sub>FAULT</sub> and maintain auto-retry functionality. The resistor/capacitor time constant determines the auto-retry time-out period.

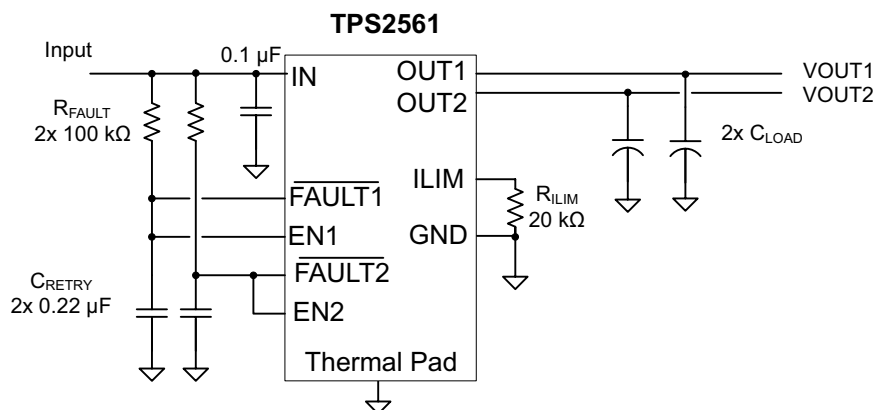

图 10-2. Auto-Retry Functionality With External EN Signal

### 10.1.2 Two-Level Current-Limit Circuit

Some applications require different current-limit thresholds depending on external system conditions. 图 10-3 shows an implementation for an externally controlled, two-level current-limit circuit. The current-limit threshold is set by the total resistance from ILIM to GND (see previously discussed *Programming the Current-Limit Threshold* section). A logic-level input enables/disables MOSFET Q1 and changes the current-limit threshold by modifying the total resistance from ILIM to GND. Additional MOSFET/resistor combinations can be used in parallel to Q1/R2 to increase the number of additional current-limit levels.

#### Note

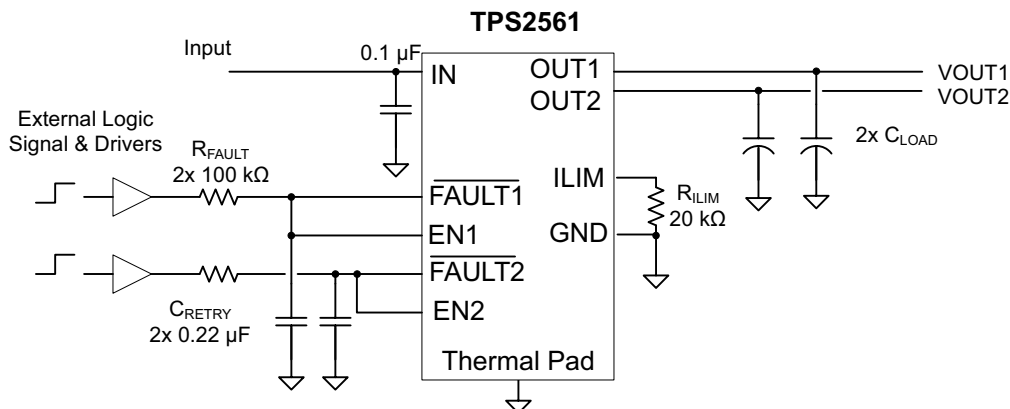
ILIM should never be driven directly with an external signal.



图 10-3. Two-Level Current-Limit Circuit

## 10.2 Typical Application

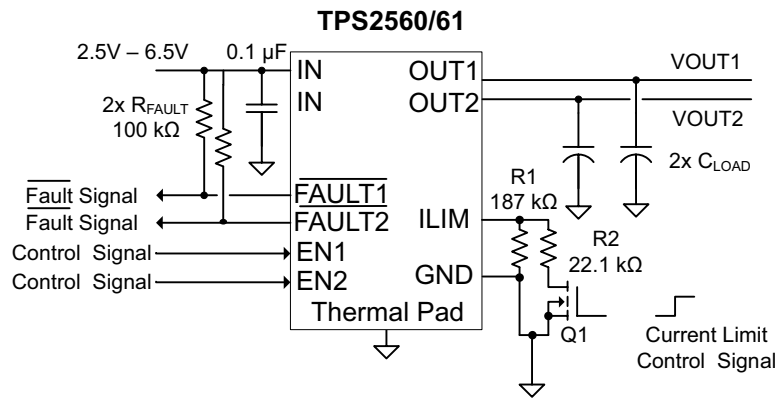

图 10-4. Typical Application Circuit

### 10.2.1 Design Requirements

See the design parameters in 表 10-1.

表 10-1. Design Parameters

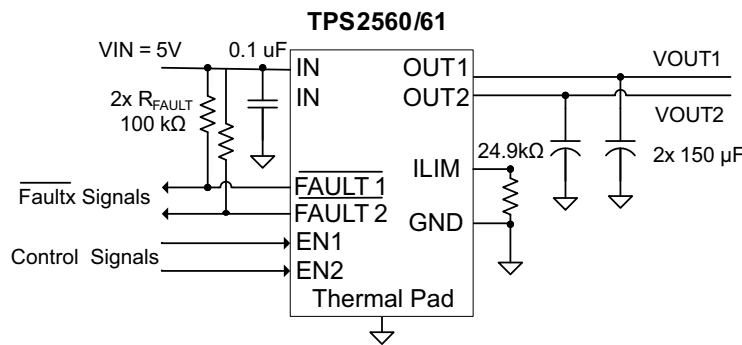
PARAMETER	VALUE
Input voltage	5 V
Output voltage	5 V
Above a minimum current limit	2000 mA
Below a minimum current limit	1000 mA

## 10.2.2 Detailed Design Procedure

### 10.2.2.1 Input and Output Capacitance

Input and output capacitance improves the performance of the device; the actual capacitance should be optimized for the particular application. For all applications, a 0.1  $\mu\text{F}$  or greater ceramic bypass capacitor between IN and GND is recommended as close to the device as possible for local noise decoupling. This precaution reduces ringing on the input due to power-supply transients. Additional input capacitance may be needed on the input to reduce voltage overshoot from exceeding the absolute maximum voltage of the device during heavy transient conditions. This is especially important during bench testing when long, inductive cables are used to connect the evaluation board to the bench power supply.

Output capacitance is not required, but placing a high-value electrolytic capacitor on the output pin is recommended when large transient currents are expected on the output.

### 10.2.2.2 Programming the Current-Limit Threshold

The overcurrent threshold is user programmable via an external resistor,  $R_{ILIM}$ .  $R_{ILIM}$  sets the current-limit threshold for both channels. The TPS256x use an internal regulation loop to provide a regulated voltage on the ILIM pin. The current-limit threshold is proportional to the current sourced out of ILIM. The recommended 1% resistor range for  $R_{ILIM}$  is  $20\text{ k}\Omega \leq R_{ILIM} \leq 187\text{ k}\Omega$  to ensure stability of the internal regulation loop. Many applications require that the minimum current limit is above a certain current level or that the maximum current limit is below a certain current level, so it is important to consider the tolerance of the overcurrent threshold when selecting a value for  $R_{ILIM}$ . The following equations calculate the resulting overcurrent threshold for a given external resistor value ( $R_{ILIM}$ ). The traces routing the  $R_{ILIM}$  resistor to the TPS256x should be as short as possible to reduce parasitic effects on the current-limit accuracy.

$$I_{OSmax}(\text{mA}) = \frac{52850V}{R_{ILIM}^{0.957}\text{k}\Omega}$$

$$I_{OSnom}(\text{mA}) = \frac{56000V}{R_{ILIM}\text{k}\Omega}$$

$$I_{OSmin}(\text{mA}) = \frac{61200V}{R_{ILIM}^{1.056}\text{k}\Omega}$$

(1)



图 10-5. Current-Limit Threshold vs  $R_{ILIM}$

### 10.2.2.3 Application 1: Designing Above a Minimum Current Limit

Some applications require that current limiting cannot occur below a certain threshold. For this example, assume that 2 A must be delivered to the load so that the minimum desired current-limit threshold is 2000 mA. Use the  $I_{OS}$  equations and [Figure 10-5](#) to select  $R_{ILIM}$ .

$$\begin{aligned}
 I_{OSmin}(\text{mA}) &= 2000\text{mA} \\
 I_{OSmin}(\text{mA}) &= \frac{61200\text{V}}{R_{ILIM}^{1.056}\text{k}\Omega} \\
 R_{ILIM}(\text{k}\Omega) &= \left( \frac{61200\text{V}}{I_{OSmin}\text{mA}} \right)^{\frac{1}{1.056}} \\
 R_{ILIM}(\text{k}\Omega) &= 25.52\text{k}\Omega
 \end{aligned} \tag{2}$$

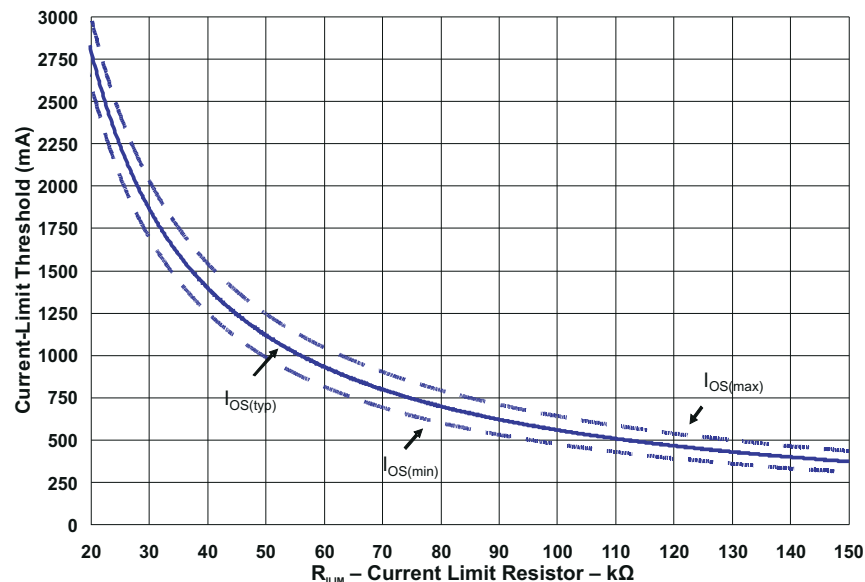
Select the closest 1% resistor less than the calculated value:  $R_{ILIM} = 25.5 \text{ k}\Omega$ . This sets the minimum current-limit threshold at 2 A. Use the  $I_{OS}$  equations, [Figure 10-5](#), and the previously calculated value for  $R_{ILIM}$  to calculate the maximum resulting current-limit threshold.

$$\begin{aligned}
 R_{ILIM}(\text{k}\Omega) &= 25.5\text{k}\Omega \\
 I_{OSmax}(\text{mA}) &= \frac{52850\text{V}}{R_{ILIM}^{0.957}\text{k}\Omega} \\
 I_{OSmax}(\text{mA}) &= \frac{52850\text{V}}{25.5^{0.957}\text{k}\Omega} \\
 I_{OSmax}(\text{mA}) &= 2382\text{mA}
 \end{aligned} \tag{3}$$

The resulting maximum current-limit threshold is 2382 mA with a 25.5-k $\Omega$  resistor.

### 10.2.2.4 Application 2: Designing Below a Maximum Current Limit

Some applications require that current limiting must occur below a certain threshold. For this example, assume that the desired upper current-limit threshold must be below 1000 mA to protect an up-stream power supply. Use the  $I_{OS}$  equations and [Figure 10-5](#) to select  $R_{ILIM}$ .

$$\begin{aligned}
 I_{OSmax}(\text{mA}) &= 1000\text{mA} \\
 I_{OSmax}(\text{mA}) &= \frac{52850\text{V}}{R_{ILIM}^{0.957}\text{k}\Omega} \\
 R_{ILIM}(\text{k}\Omega) &= \left( \frac{52850\text{V}}{I_{OSmax}\text{mA}} \right)^{\frac{1}{0.957}} \\
 R_{ILIM}(\text{k}\Omega) &= 63.16\text{k}\Omega
 \end{aligned} \tag{4}$$

Select the closest 1% resistor greater than the calculated value:  $R_{ILIM} = 63.4 \text{ k}\Omega$ . This sets the maximum current-limit threshold at 1000 mA. Use the  $I_{OS}$  equations, [Figure 10-5](#), and the previously calculated value for  $R_{ILIM}$  to calculate the minimum resulting current-limit threshold.

$$\begin{aligned}
 R_{ILIM}(\text{k}\Omega) &= 63.4\text{k}\Omega \\
 I_{OSmin}(\text{mA}) &= \frac{61200\text{V}}{R_{ILIM}^{1.056}\text{k}\Omega} \\
 I_{OSmin}(\text{mA}) &= \frac{61200\text{V}}{63.4^{1.056}\text{k}\Omega} \\
 I_{OSmin}(\text{mA}) &= 765\text{mA}
 \end{aligned} \tag{5}$$

The resulting minimum current-limit threshold is 765 mA with a 63.4 k $\Omega$  resistor.

### 10.2.2.5 Accounting for Resistor Tolerance

The previous sections described the selection of  $R_{ILIM}$  given certain application requirements and the importance of understanding the current-limit threshold tolerance. The analysis focused only on the TPS256x performance and assumed an exact resistor value. However, resistors sold in quantity are not exact and are bounded by an upper and lower tolerance centered around a nominal resistance. The additional  $R_{ILIM}$  resistance tolerance directly affects the current-limit threshold accuracy at a system level. The following table shows a process that accounts for worst-case resistor tolerance assuming 1% resistor values. Step one follows the selection process outlined in the application examples above. Step two determines the upper and lower resistance bounds of the selected resistor. Step three uses the upper and lower resistor bounds in the  $I_{OS}$  equations to calculate the threshold limits. It is important to use tighter tolerance resistors, e.g. 0.5% or 0.1%, when precision current limiting is desired.

表 10-2. Common  $R_{ILIM}$  Resistor Selections

DESIRED NOMINAL CURRENT LIMIT	IDEAL RESISTOR	CLOSEST 1% RESISTOR	1% LOW RESISTOR TOLERANCE	1% HIGH RESISTOR TOLERANCE	IOS ACTUAL LIMITS			
					MIN	NOM	MAX	UNIT
300 mA	186.7 k $\Omega$	187 k $\Omega$	185.1 k $\Omega$	188.9 k $\Omega$	241.6	299.5	357.3	mA
400 mA	140.0 k $\Omega$	140 k $\Omega$	138.6 k $\Omega$	141.4 k $\Omega$	328.0	400.0	471.4	mA
600 mA	93.3 k $\Omega$	93.1 k $\Omega$	92.2 k $\Omega$	94.0 k $\Omega$	504.6	601.5	696.5	mA
800 mA	70.0 k $\Omega$	69.8 k $\Omega$	69.1 k $\Omega$	70.5 k $\Omega$	684.0	802.3	917.6	mA
1000 mA	56.0 k $\Omega$	56.2 k $\Omega$	55.6 k $\Omega$	56.8 k $\Omega$	859.9	996.4	1129.1	mA
1200 mA	46.7 k $\Omega$	46.4 k $\Omega$	45.9 k $\Omega$	46.9 k $\Omega$	1052.8	1206.9	1356.3	mA
1400 mA	40.0 k $\Omega$	40.2 k $\Omega$	39.8 k $\Omega$	40.6 k $\Omega$	1225.0	1393.0	1555.9	mA
1600 mA	35.0 k $\Omega$	34.8 k $\Omega$	34.5 k $\Omega$	35.1 k $\Omega$	1426.5	1609.2	1786.2	mA
1800 mA	31.1 k $\Omega$	30.9 k $\Omega$	30.6 k $\Omega$	31.2 k $\Omega$	1617.3	1812.3	2001.4	mA
2000 mA	28.0 k $\Omega$	28 k $\Omega$	27.7 k $\Omega$	28.3 k $\Omega$	1794.7	2000.0	2199.3	mA
2200 mA	25.5 k $\Omega$	25.5 k $\Omega$	25.2 k $\Omega$	25.8 k $\Omega$	1981.0	2196.1	2405.3	mA
2400 mA	23.3 k $\Omega$	23.2 k $\Omega$	23.0 k $\Omega$	23.4 k $\Omega$	2188.9	2413.8	2633.0	mA
2600 mA	21.5 k $\Omega$	21.5 k $\Omega$	21.3 k $\Omega$	21.7 k $\Omega$	2372.1	2604.7	2831.9	mA
2800 mA	20.0 k $\Omega$	20 k $\Omega$	19.8 k $\Omega$	20.2 k $\Omega$	2560.4	2800.0	3034.8	mA



### 10.2.3 Application Curves

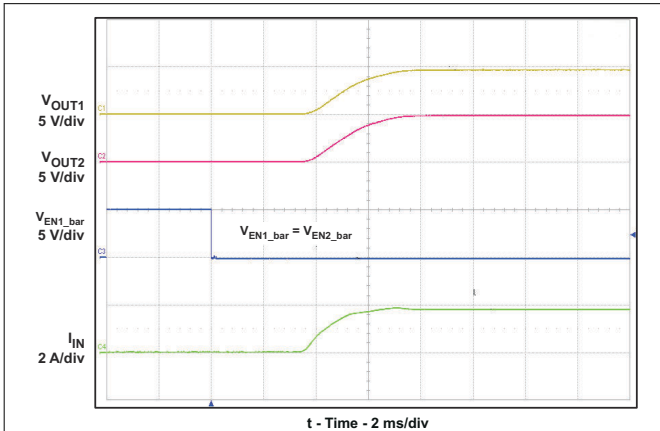

**图 10-6. Turn-On Delay and Rise Time**

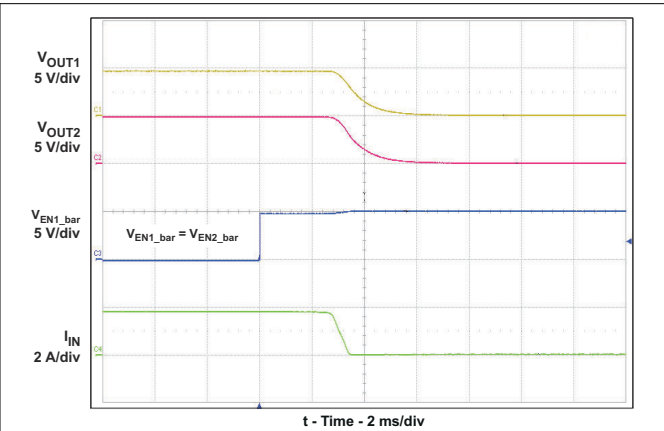

**图 10-7. Turn-Off Delay and Fall Time**

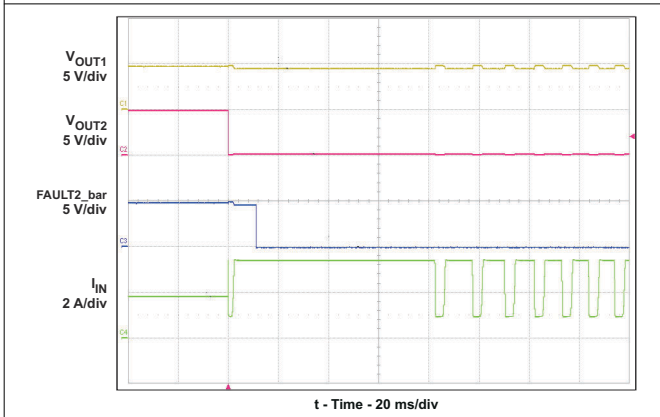

**图 10-8. Full-Load to Short-Circuit Transient Response**

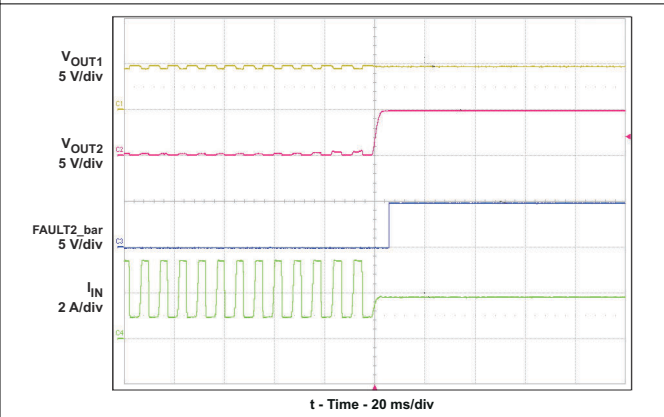

**图 10-9. Short-Circuit to Full-Load Recovery Response**

## 10 Power Supply Recommendations

### 10.1 Self-Powered and Bus-Powered Hubs

A SPH has a local power supply that powers embedded functions and downstream ports. This power supply must provide between 4.75 V to 5.25 V to downstream facing devices under full-load and no-load conditions. SPHs are required to have current-limit protection and must report overcurrent conditions to the USB controller. Typical SPHs are desktop PCs, monitors, printers, and stand-alone hubs. A BPH obtains all power from an upstream port and often contains an embedded function. It must power up with less than 100 mA. The BPH usually has one embedded function, and power is always available to the controller of the hub. If the embedded function and hub require more than 100 mA on power up, the power to the embedded function may need to be kept off until enumeration is completed. This is accomplished by removing power or by shutting off the clock to the embedded function. Power switching the embedded function is not necessary if the aggregate power draw for the function and controller is less than 100 mA. The total current drawn by the bus-powered device is the sum of the current to the controller, the embedded function, and the downstream ports, and it is limited to 500 mA from an upstream port.

### 10.2 Low-Power Bus-Powered and High-Power Bus-Powered Functions

Both low-power and high-power bus-powered functions obtain all power from upstream ports. Low-power functions always draw less than 100 mA; high-power functions must draw less than 100 mA at power up and can draw up to 500 mA after enumeration. If the load of the function is more than the parallel combination of 44  $\Omega$  and 10  $\mu$ F at power up, the device must implement inrush current limiting.

## 11 Layout

### 11.1 Layout Guidelines

- Place the 100-nF bypass capacitor near the IN and GND pins, and make the connections using a low-inductance trace
- Place a high-value electrolytic capacitor and a 100-nF bypass capacitor on the output pin is recommended when large transient currents are expected on the output
- The traces routing the RILIM resistor to the device should be as short as possible to reduce parasitic effects on the current limit accuracy
- The thermal pad should be directly connected to PCB ground plane using wide and short copper trace

#### 11.1.1 Power Dissipation

The low on-resistance of the N-channel MOSFET allows small surface-mount packages to pass large currents. It is good design practice to estimate power dissipation and junction temperature. The below analysis gives an approximation for calculating junction temperature based on the power dissipation in the package. However, it is important to note that thermal analysis is strongly dependent on additional system level factors. Such factors include air flow, board layout, copper thickness and surface area, and proximity to other devices dissipating power. Good thermal design practice must include all system level factors in addition to individual component analysis.

Begin by determining the  $r_{DS(on)}$  of the N-channel MOSFET relative to the input voltage and operating temperature. As an initial estimate, use the highest operating ambient temperature of interest and read  $r_{DS(on)}$  from the typical characteristics graph. Using this value, the power dissipation can be calculated with [方程式 6](#). This step calculates the total power dissipation of the N-channel MOSFET.

$$P_D = (R_{DS(on)} \times I_{OUT1}^2) + (R_{DS(on)} \times I_{OUT2}^2) \quad (6)$$

where

- $P_D$  = Total power dissipation (W)
- $r_{DS(on)}$  = Power switch on-resistance of one channel ( $\Omega$ )
- $I_{OUTx}$  = Maximum current-limit threshold set by  $R_{ILIM}$ (A)

Finally, calculate the junction temperature with 方程式 7.

$$T_J = P_D \times R_{\theta JA} + T_A \tag{7}$$

where

- $T_A$  = Ambient temperature (°C)
- $R_{\theta JA}$  = Thermal resistance (°C/W)
- $P_D$  = Total power dissipation (W)

Compare the calculated junction temperature with the initial estimate. If they are not within a few degrees, repeat the calculation using the "refined"  $r_{DS(on)}$  from the previous calculation as the new estimate. Two or three iterations are generally sufficient to achieve the desired result. The final junction temperature is highly dependent on thermal resistance  $R_{\theta JA}$ , and thermal resistance is highly dependent on the individual package and board layout. The [Dissipation Ratings](#) table provides example thermal resistances for specific packages and board layouts.

### 11.2 Layout Example



图 11-1. Layout Recommendation

## 12 Device and Documentation Support

### 12.1 接收文档更新通知

要接收文档更新通知，请导航至 [ti.com](http://ti.com) 上的器件产品文件夹。点击 [订阅更新](#) 进行注册，即可每周接收产品信息更改摘要。有关更改的详细信息，请查看任何已修订文档中包含的修订历史记录。

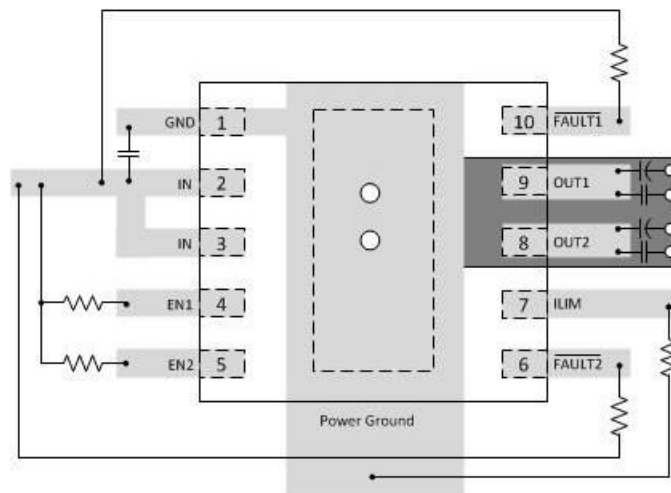
### 12.2 支持资源

**TI E2E™ 支持论坛** 是工程师的重要参考资料，可直接从专家获得快速、经过验证的解答和设计帮助。搜索现有解答或提出自己的问题可获得所需的快速设计帮助。

链接的内容由各个贡献者“按原样”提供。这些内容并不构成 TI 技术规范，并且不一定反映 TI 的观点；请参阅 TI 的《[使用条款](#)》。

### 12.3 Trademarks

TI E2E™ is a trademark of Texas Instruments.

所有商标均为其各自所有者的财产。

### 12.4 静电放电警告



静电放电 (ESD) 会损坏这个集成电路。德州仪器 (TI) 建议通过适当的预防措施处理所有集成电路。如果不遵守正确的处理和安装程序，可能会损坏集成电路。

ESD 的损坏小至导致微小的性能降级，大至整个器件故障。精密的集成电路可能更容易受到损坏，这是因为非常细微的参数更改都可能会导致器件与其发布的规格不相符。

### 12.5 术语表

**TI 术语表** 本术语表列出并解释了术语、首字母缩略词和定义。

## 13 Mechanical, Packaging, and Orderable Information

The following pages include mechanical, packaging, and orderable information. This information is the most current data available for the designated devices. This data is subject to change without notice and revision of this document. For browser-based versions of this data sheet, refer to the left-hand navigation.

**PACKAGING INFORMATION**

Orderable Device	Status (1)	Package Type	Package Drawing	Pins	Package Qty	Eco Plan (2)	Lead finish/ Ball material (6)	MSL Peak Temp (3)	Op Temp (°C)	Device Marking (4/5)	Samples
TPS2560DRCR	ACTIVE	VSON	DRC	10	3000	RoHS & Green	NIPDAU	Level-2-260C-1 YEAR	-40 to 125	2560	<a href="#">Samples</a>
TPS2560DRCT	ACTIVE	VSON	DRC	10	250	RoHS & Green	NIPDAU	Level-2-260C-1 YEAR	-40 to 125	2560	<a href="#">Samples</a>
TPS2561DRCR	ACTIVE	VSON	DRC	10	3000	RoHS & Green	NIPDAU	Level-2-260C-1 YEAR	-40 to 125	2561	<a href="#">Samples</a>
TPS2561DRCT	ACTIVE	VSON	DRC	10	250	RoHS & Green	NIPDAU	Level-2-260C-1 YEAR	-40 to 125	2561	<a href="#">Samples</a>

(1) The marketing status values are defined as follows:

**ACTIVE:** Product device recommended for new designs.

**LIFEBUY:** TI has announced that the device will be discontinued, and a lifetime-buy period is in effect.

**NRND:** Not recommended for new designs. Device is in production to support existing customers, but TI does not recommend using this part in a new design.

**PREVIEW:** Device has been announced but is not in production. Samples may or may not be available.

**OBSELETE:** TI has discontinued the production of the device.

(2) **RoHS:** TI defines "RoHS" to mean semiconductor products that are compliant with the current EU RoHS requirements for all 10 RoHS substances, including the requirement that RoHS substance do not exceed 0.1% by weight in homogeneous materials. Where designed to be soldered at high temperatures, "RoHS" products are suitable for use in specified lead-free processes. TI may reference these types of products as "Pb-Free".

**RoHS Exempt:** TI defines "RoHS Exempt" to mean products that contain lead but are compliant with EU RoHS pursuant to a specific EU RoHS exemption.

**Green:** TI defines "Green" to mean the content of Chlorine (Cl) and Bromine (Br) based flame retardants meet JS709B low halogen requirements of <=1000ppm threshold. Antimony trioxide based flame retardants must also meet the <=1000ppm threshold requirement.

(3) MSL, Peak Temp. - The Moisture Sensitivity Level rating according to the JEDEC industry standard classifications, and peak solder temperature.

(4) There may be additional marking, which relates to the logo, the lot trace code information, or the environmental category on the device.

(5) Multiple Device Markings will be inside parentheses. Only one Device Marking contained in parentheses and separated by a "-" will appear on a device. If a line is indented then it is a continuation of the previous line and the two combined represent the entire Device Marking for that device.

(6) Lead finish/Ball material - Orderable Devices may have multiple material finish options. Finish options are separated by a vertical ruled line. Lead finish/Ball material values may wrap to two lines if the finish value exceeds the maximum column width.

**Important Information and Disclaimer:**The information provided on this page represents TI's knowledge and belief as of the date that it is provided. TI bases its knowledge and belief on information provided by third parties, and makes no representation or warranty as to the accuracy of such information. Efforts are underway to better integrate information from third parties. TI has taken and

continues to take reasonable steps to provide representative and accurate information but may not have conducted destructive testing or chemical analysis on incoming materials and chemicals. TI and TI suppliers consider certain information to be proprietary, and thus CAS numbers and other limited information may not be available for release.

In no event shall TI's liability arising out of such information exceed the total purchase price of the TI part(s) at issue in this document sold by TI to Customer on an annual basis.

**OTHER QUALIFIED VERSIONS OF TPS2561 :**

- Automotive : [TPS2561-Q1](#)

NOTE: Qualified Version Definitions:

- Automotive - Q100 devices qualified for high-reliability automotive applications targeting zero defects

**TAPE AND REEL INFORMATION**

**QUADRANT ASSIGNMENTS FOR PIN 1 ORIENTATION IN TAPE**

\*All dimensions are nominal

Device	Package Type	Package Drawing	Pins	SPQ	Reel Diameter (mm)	Reel Width W1 (mm)	A0 (mm)	B0 (mm)	K0 (mm)	P1 (mm)	W (mm)	Pin1 Quadrant
TPS2560DRCR	VSON	DRC	10	3000	330.0	12.4	3.3	3.3	1.1	8.0	12.0	Q2
TPS2560DRCR	VSON	DRC	10	3000	330.0	12.4	3.3	3.3	1.1	8.0	12.0	Q2
TPS2560DRCT	VSON	DRC	10	250	180.0	12.4	3.3	3.3	1.1	8.0	12.0	Q2
TPS2560DRCT	VSON	DRC	10	250	180.0	12.5	3.3	3.3	1.1	8.0	12.0	Q2
TPS2561DRCR	VSON	DRC	10	3000	330.0	12.4	3.3	3.3	1.1	8.0	12.0	Q2
TPS2561DRCT	VSON	DRC	10	250	180.0	12.4	3.3	3.3	1.1	8.0	12.0	Q2



**TAPE AND REEL BOX DIMENSIONS**

\*All dimensions are nominal

Device	Package Type	Package Drawing	Pins	SPQ	Length (mm)	Width (mm)	Height (mm)
TPS2560DRCR	VSON	DRC	10	3000	367.0	367.0	35.0
TPS2560DRCR	VSON	DRC	10	3000	338.0	355.0	50.0
TPS2560DRCT	VSON	DRC	10	250	210.0	185.0	35.0
TPS2560DRCT	VSON	DRC	10	250	338.0	355.0	50.0
TPS2561DRCR	VSON	DRC	10	3000	367.0	367.0	35.0
TPS2561DRCT	VSON	DRC	10	250	210.0	185.0	35.0

## GENERIC PACKAGE VIEW

**DRC 10**

**VSON - 1 mm max height**

3 x 3, 0.5 mm pitch

PLASTIC SMALL OUTLINE - NO LEAD

This image is a representation of the package family, actual package may vary.  
Refer to the product data sheet for package details.



4226193/A



# EXAMPLE BOARD LAYOUT

DRC0010J

VSON - 1 mm max height

PLASTIC SMALL OUTLINE - NO LEAD



LAND PATTERN EXAMPLE  
EXPOSED METAL SHOWN  
SCALE:20X



SOLDER MASK DETAILS

4218878/B 07/2018

NOTES: (continued)

4. This package is designed to be soldered to a thermal pad on the board. For more information, see Texas Instruments literature number SLUA271 ([www.ti.com/lit/sluea271](http://www.ti.com/lit/sluea271)).
5. Vias are optional depending on application, refer to device data sheet. If any vias are implemented, refer to their locations shown on this view. It is recommended that vias under paste be filled, plugged or tented.

# EXAMPLE STENCIL DESIGN

DRC0010J

VSON - 1 mm max height

PLASTIC SMALL OUTLINE - NO LEAD



SOLDER PASTE EXAMPLE  
BASED ON 0.125 mm THICK STENCIL

EXPOSED PAD 11:  
80% PRINTED SOLDER COVERAGE BY AREA  
SCALE:25X

4218878/B 07/2018

NOTES: (continued)

6. Laser cutting apertures with trapezoidal walls and rounded corners may offer better paste release. IPC-7525 may have alternate design recommendations.

## 重要声明和免责声明

TI“按原样”提供技术和可靠性数据（包括数据表）、设计资源（包括参考设计）、应用或其他设计建议、网络工具、安全信息和其他资源，不保证没有瑕疵且不做任何明示或暗示的担保，包括但不限于对适销性、某特定用途方面的适用性或不侵犯任何第三方知识产权的暗示担保。

这些资源可供使用 TI 产品进行设计的熟练开发人员使用。您将自行承担以下全部责任：(1) 针对您的应用选择合适的 TI 产品，(2) 设计、验证并测试您的应用，(3) 确保您的应用满足相应标准以及任何其他功能安全、信息安全、监管或其他要求。

这些资源如有变更，恕不另行通知。TI 授权您仅可将这些资源用于研发本资源所述的 TI 产品的应用。严禁对这些资源进行其他复制或展示。您无权使用任何其他 TI 知识产权或任何第三方知识产权。您应全额赔偿因在这些资源的使用中对 TI 及其代表造成的任何索赔、损害、成本、损失和债务，TI 对此概不负责。

TI 提供的产品受 [TI 的销售条款](#) 或 [ti.com](#) 上其他适用条款/TI 产品随附的其他适用条款的约束。TI 提供这些资源并不会扩展或以其他方式更改 TI 针对 TI 产品发布的适用的担保或担保免责声明。

TI 反对并拒绝您可能提出的任何其他或不同的条款。

邮寄地址：Texas Instruments, Post Office Box 655303, Dallas, Texas 75265

Copyright © 2023，德州仪器 (TI) 公司