

SN74LV374A 具有三态输出的八路边沿触发 D 类触发器

1 特性

- V_{CC} 工作范围为 2V 至 5.5V
- 5V 时 t_{pd} 最大值为 9.5ns
- V_{OLP} (输出接地反弹) 典型值小于 0.8V ($V_{CC} = 3.3V, T_A = 25^\circ C$)
- V_{OHV} (输出 V_{OH} 下冲) 典型值大于 2.3V ($V_{CC} = 3.3V, T_A = 25^\circ C$)
- 所有端口上均支持以混合模式电压运行
- I_{off} 支持局部关断模式运行
- 闩锁性能超过 250mA, 符合 JESD 17 规范

2 应用

- 可编程逻辑控制器 (PLC)
- DCS 和 PAC: 模拟输入模块
- 火车、有轨电车和地铁车厢
- 交流逆变器驱动器
- 打印机

3 说明

SN74LV374A 器件是八路边沿触发 D 类触发器, 旨在 2V 至 5.5V V_{CC} 下运行。

封装信息

器件型号	封装	封装尺寸 (标称值)
SN74LV374ADB	SSOP (20)	7.20mm × 5.30mm
SN74LV374ADW	SOIC (20)	12.80mm × 7.50mm
SN74LV374ANS	SO (20)	12.60mm × 5.30mm
SN74LV374APW	TSSOP (20)	6.50mm × 4.40mm

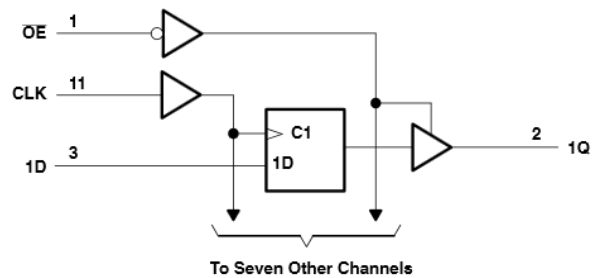

所示引脚编号用于 DB、DW、NS、PW 和 RGY 封装。

逻辑图 (正逻辑)

Table of Contents

1 特性	1	6.12 Typical Characteristics.....	8
2 应用	1	7 Parameter Measurement Information	9
3 说明	1	8 Detailed Description	10
5 Pin Configuration and Functions	2	8.1 Overview.....	10
Pin Functions.....	3	8.2 Functional Block Diagram.....	10
6 Specifications	4	8.3 Feature Description.....	10
6.1 Absolute Maximum Ratings.....	4	8.4 Device Functional Modes.....	10
6.2 ESD Ratings.....	4	9 Power Supply Recommendations	13
6.3 Recommended Operating Conditions.....	5	10 Layout	14
6.4 Thermal Information.....	5	10.1 Layout Guidelines.....	14
6.5 Electrical Characteristics.....	6	10.2 Layout Example.....	14
6.6 Switching Characteristics: $V_{CC} = 2.5\text{ V} \pm 0.2\text{ V}$	6	11 Device and Documentation Support	15
6.7 Switching Characteristics: $V_{CC} = 3.3\text{ V} \pm 0.3\text{ V}$	7	11.1 Documentation Support.....	15
6.8 Switching Characteristics: $V_{CC} = 5\text{ V} \pm 0.5\text{ V}$	7	11.2 Related Links.....	15
6.9 Timing Requirements.....	7	11.3 Receiving Notification of Documentation Updates..	15
6.10 Noise Characteristics.....	8	11.4 Community Resources.....	15
6.11 Operating Characteristics, $T_A = 25^\circ\text{C}$	8	11.5 Trademarks.....	15

4

注：以前版本的页码可能与当前版本的页码不同

Changes from Revision J (March 2015) to Revision K (December 2022)

Page

- 通篇更新了表格、图和交叉参考的格式..... 1

Changes from Revision I (March 2015) to Revision J (October 2016)

Page

- Added Junction temperature, T_J 4
- Deleted " $V_{CC} \times 0.3$ " from MIN and added " $V_{CC} \times 0.3$ " to MAX for SN54LV374A and SN74LV374A..... 5
- Changed "SN54LV384A" to "SN54LV374A" in *Electrical Characteristics* table..... 6
- Added *Related Links* section, *Receiving Notification of Documentation Updates* section, and *Community Resources* section..... 15

Changes from Revision H (April 2005) to Revision I (March 2015)

Page

- 添加了引脚配置和功能部分、ESD 等级表、特性说明部分、器件功能模式、应用和实现部分、电源相关建议部分、布局部分、器件和文档支持部分以及机械、封装和可订购信息部分 1

5 Pin Configuration and Functions



图 5-1. DB, DW, NS, or PW Package 20-PIN SSOP, SOIC, SO, or TSSOP Top View

Pin Functions

PIN		TYPE	DESCRIPTION
NAME	NO.		
OE	1	I	Enable pin
1Q	2	O	Output 1
1D	3	I	Input 1
2D	4	I	Input 2
2Q	5	O	Output 2
3Q	6	O	Output 3
3D	7	I	Input 3
4D	8	I	Input 4
4Q	9	O	Output 4
GND	10	–	Ground pin
CLK	11	I	Clock pin
5Q	12	O	Output 5
5D	13	I	Input 5
6D	14	I	Input 6
6Q	15	O	Output 6
7Q	16	O	Output 7
7D	17	I	Input 7
8D	18	I	Input 8
8Q	19	O	Output 8
V _{CC}	20	–	Power pin

6 Specifications

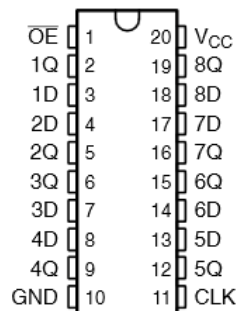
6.1 Absolute Maximum Ratings

over operating free-air temperature range (unless otherwise noted) ⁽¹⁾

		MIN	MAX	UNIT
V _{CC}	Supply voltage	-0.5	7	V
V _I	Input voltage ⁽²⁾	-0.5	7	V
V _O	Voltage applied to any output in the high-impedance or power-off state ⁽²⁾	-0.5	7	V
V _O	Output voltage ⁽²⁾ ⁽³⁾	-0.5	V _{CC} + 0.5	V
I _{IK}	Input clamp current, (V _I < 0)		-20	mA
I _{OK}	Output clamp current, (V _O < 0)		-50	mA
I _O	Continuous output current, (V _O = 0 to V _{CC})		±35	mA
	Continuous current through V _{CC} or GND		±70	mA
T _J	Junction temperature		150	°C
T _{stg}	Storage temperature	-65	150	°C

- (1) Stresses beyond those listed under *Absolute Maximum Ratings* may cause permanent damage to the device. These are stress ratings only, which do not imply functional operation of the device at these or any other conditions beyond those indicated under *Recommended Operating Conditions*. Exposure to absolute-maximum-rated conditions for extended periods may affect device reliability.
- (2) The input and output negative-voltage ratings may be exceeded if the input and output current ratings are observed.
- (3) This value is limited to 5.5 V maximum.

6.2 ESD Ratings

			VALUE	UNIT
V _(ESD)	Electrostatic discharge	Human body model (HBM), per ANSI/ESDA/JEDEC JS-001 ⁽¹⁾	±2000	V
		Charged-device model (CDM), per JEDEC specification JESD22-C101 ⁽²⁾	±1000	
		Machine Model (A115-A)	±200	

- (1) JEDEC document JEP155 states that 500-V HBM allows safe manufacturing with a standard ESD control process.
- (2) JEDEC document JEP157 states that 250-V CDM allows safe manufacturing with a standard ESD control process.

6.3 Recommended Operating Conditions

over operating free-air temperature range (unless otherwise noted) ⁽¹⁾

		SN74LV374A		UNIT	
		MIN	MAX		
V _{CC}	Supply voltage	2	5.5	V	
V _{IH}	High-level input voltage	V _{CC} = 2 V	1.5	V	
		V _{CC} = 2.3 V to 2.7 V	V _{CC} × 0.7		
		V _{CC} = 3 V to 3.6 V	V _{CC} × 0.7		
		V _{CC} = 4.5 V to 5.5 V	V _{CC} × 0.77		
V _{IL}	Low-level input voltage	V _{CC} = 2 V	0.5	V	
		V _{CC} = 2.3 V to 2.7 V	V _{CC} × 0.3		
		V _{CC} = 3 V to 3.6 V	V _{CC} × 0.3		
		V _{CC} = 4.5 V to 5.5 V	V _{CC} × 0.3		
V _I	Input voltage	0	5.5	V	
V _O	Output voltage	High or low state	0	V _{CC}	V
		3-state	0	5.5	
I _{OH}	High-level output current	V _{CC} = 2 V		-50	μA
		V _{CC} = 2.3 V to 2.7 V		-2	mA
		V _{CC} = 3 V to 3.6 V		-8	
		V _{CC} = 4.5 V to 5.5 V		-16	
I _{OL}	Low-level output current	V _{CC} = 2 V		50	μA
		V _{CC} = 2.3 V to 2.7 V		2	mA
		V _{CC} = 3 V to 3.6 V		8	
		V _{CC} = 4.5 V to 5.5 V		16	
Δt/Δv	Input transition rise or fall rate	V _{CC} = 2.3 V to 2.7 V		200	ns/V
		V _{CC} = 3 V to 3.6 V		100	
		V _{CC} = 4.5 V to 5.5 V		20	
T _A	Operating free-air temperature	-40	125	°C	

(1) All unused inputs of the device must be held at V_{CC} or GND to ensure proper device operation. See [Implications of Slow or Floating CMOS Inputs](#), SCBA004.

6.4 Thermal Information

THERMAL METRIC ⁽¹⁾		SN74LV374A				UNIT
		DB (SSOP)	DW (SOIC)	NS (SO)	PW (TSSOP)	
		20 PINS	20 PINS	20 PINS	20 PINS	
R _{θJA}	Junction-to-ambient thermal resistance	94.5	79.2	76.7	102.4	°C/W
R _{θJC(top)}	Junction-to-case (top) thermal resistance	56.4	43.7	43.2	36.5	°C/W
R _{θJB}	Junction-to-board thermal resistance	49.7	47	44.2	53.6	°C/W
ψ _{JT}	Junction-to-top characterization parameter	18.5	18.6	16.8	2.4	°C/W
ψ _{JB}	Junction-to-board characterization parameter	49.3	46.5	43.8	52.9	°C/W

(1) For more information about traditional and new thermal metrics, see the [Semiconductor and IC Package Thermal Metrics](#) application report.

6.5 Electrical Characteristics

over recommended operating free-air temperature range (unless otherwise noted)

PARAMETER	TEST CONDITIONS	V _{CC}	SN74LV374A –40°C to +85°C			SN74LV374A –40°C to +125°C			UNIT
			MIN	TYP	MAX	MIN	TYP	MAX	
V _{OH}	I _{OH} = –50 μA	2 V to 5.5 V	V _{CC} –0.1			V _{CC} –0.1			V
	I _{OH} = –2 mA	2.3 V	2			2			
	I _{OH} = –8 mA	3 V	2.48			2.48			
	I _{OH} = –16 mA	4.5 V	3.8			3.8			
V _{OL}	I _{OL} = 50 μA	2 V to 5.5 V				0.1			V
	I _{OL} = 2 mA	2.3 V				0.4			
	I _{OL} = 8 mA	3 V				0.44			
	I _{OL} = 16 mA	4.5 V				0.55			
I _I	V _I = 5.5 V or GND	0 to 5.5 V				±1			μA
I _{OZ}	V _O = V _{CC} or GND	5.5 V				±5			μA
I _{CC}	V _I = V _{CC} or GND, I _O = 0	5.5 V				20			μA
I _{off}	V _I or V _O = 0 to 5.5 V	0				5			μA
C _i	V _I = V _{CC} or GND	3.3 V	2.9			2.9			pF

6.6 Switching Characteristics: V_{CC} = 2.5 V ± 0.2 V

over recommended operating free-air temperature range, V_{CC} = 2.5 V ± 0.2 V (unless otherwise noted)

PARAMETER	FROM (INPUT)	TO (OUTPUT)	LOAD CAPACITANCE	T _A = 25°C			SN74LV374A –40°C to +85°C		SN74LV374A –40°C to +125°C		UNIT
				MIN	TYP	MAX	MIN	MAX	MIN	MAX	
f _{max}			C _L = 15 pF	60 ⁽¹⁾	105 ⁽¹⁾		50		50		MHz
			C _L = 50 pF	50	85		40		40		
t _{pd}	CLK	Q	C _L = 15 pF		9.7 ⁽¹⁾	16.3 ⁽¹⁾	1	19	1	20.5	ns
t _{en}	OE	Q			8.9 ⁽¹⁾	15.9 ⁽¹⁾	1	19	1	20.5	
t _{dis}	OE	Q			6.3 ⁽¹⁾	12.6 ⁽¹⁾	1	15	1	16.5	
t _{pd}	CLK	Q	C _L = 50 pF		11.8	19.3	1	23	1	24.5	ns
t _{en}	OE	Q			10.9	18.8	1	22	1	23.5	
t _{dis}	OE	Q			8.2	17.3	1	19	1	20.5	
t _{sk(o)}							2		2		

(1) On products compliant to MIL-PRF-38535, this parameter is not production tested.

6.7 Switching Characteristics: $V_{CC} = 3.3\text{ V} \pm 0.3\text{ V}$

over recommended operating free-air temperature range, $V_{CC} = 3.3\text{ V} \pm 0.3\text{ V}$ (unless otherwise noted)

PARAMETER	FROM (INPUT)	TO (OUTPUT)	LOAD CAPACITANCE	$T_A = 25^\circ\text{C}$			SN74LV374A –40°C to +85°C		SN74LV374A –40°C to +125°C		UNIT
				MIN	TYP	MAX	MIN	MAX	MIN	MAX	
f_{max}			$C_L = 15\text{ pF}$	80 ⁽¹⁾	150 ⁽¹⁾		70		70	MHz	
			$C_L = 50\text{ pF}$	55	110		50		50		
t_{pd}	CLK	Q	$C_L = 15\text{ pF}$		6.8 ⁽¹⁾	12.7 ⁽¹⁾	1	15	1	16	ns
t_{en}	$\overline{\text{OE}}$	Q			6.3 ⁽¹⁾	11 ⁽¹⁾	1	13	1	14	
t_{dis}	$\overline{\text{OE}}$	Q			4.7 ⁽¹⁾	10.5 ⁽¹⁾	1	12.5	1	13.5	
t_{pd}	CLK	Q	$C_L = 50\text{ pF}$		8.3	16.2	1	18.5	1	19.5	ns
t_{en}	$\overline{\text{OE}}$	Q			7.7	14.5	1	16.5	1	17.5	
t_{dis}	$\overline{\text{OE}}$	Q			5.9	14	1	16	1	17	
$t_{\text{sk(o)}}$								1.5		1.5	

(1) On products compliant to MIL-PRF-38535, this parameter is not production tested.

6.8 Switching Characteristics: $V_{CC} = 5\text{ V} \pm 0.5\text{ V}$

over recommended operating free-air temperature range, $V_{CC} = 5\text{ V} \pm 0.5\text{ V}$ (unless otherwise noted)

PARAMETER	FROM (INPUT)	TO (OUTPUT)	LOAD CAPACITANCE	$T_A = 25^\circ\text{C}$			SN74LV374A –40°C to +85°C		SN74LV374A –40°C to +125°C		UNIT
				MIN	TYP	MAX	MIN	MAX	MIN	MAX	
f_{max}			$C_L = 15\text{ pF}$	130 ⁽¹⁾	205 ⁽¹⁾		110		110	MHz	
			$C_L = 50\text{ pF}$	85	1705		75		75		
t_{pd}	CLK	Q	$C_L = 15\text{ pF}$		4.9 ⁽¹⁾	8.1 ⁽¹⁾	1	9.5	1	10.5	ns
t_{en}	$\overline{\text{OE}}$	Q			4.6 ⁽¹⁾	7.6 ⁽¹⁾	1	9	1	10	
t_{dis}	$\overline{\text{OE}}$	Q			3.4 ⁽¹⁾	6.8 ⁽¹⁾	1	8	1	9	
t_{pd}	CLK	Q	$C_L = 50\text{ pF}$		5.9	10.1	1	11.5	1	12.5	ns
t_{en}	$\overline{\text{OE}}$	Q			5.5	9.6	1	11	1	12	
t_{dis}	$\overline{\text{OE}}$	Q			4	8.8	1	10	1	11	
$t_{\text{sk(o)}}$								1		1	

(1) On products compliant to MIL-PRF-38535, this parameter is not production tested.

6.9 Timing Requirements

over recommended operating free-air temperature range, (unless otherwise noted) (see [Figure 7-1](#))

		$T_A = 25^\circ\text{C}$		SN74LV374A –40°C to +85°C		SN74LV374A –40°C to +125°C		UNIT
		MIN	MAX	MIN	MAX	MIN	MAX	
$V_{CC} = 2.5\text{ V} \pm 0.2\text{ V}$								
t_w	Pulse duration, CLK high or low	6		7		7		ns
t_{su}	Setup time, data before CLK \uparrow	5		5.5		6		ns
t_h	Hold time, data after CLK \uparrow	2.5		2.5		3		ns
$V_{CC} = 3.3\text{ V} \pm 0.3\text{ V}$								
t_w	Pulse duration, CLK high or low	5		5.5		5.5		ns
t_{su}	Setup time, data before CLK \uparrow	4.5		4.5		5		ns
t_h	Hold time, data after CLK \uparrow	2		2		2.5		ns
$V_{CC} = 5\text{ V} \pm 0.5\text{ V}$								
t_w	Pulse duration, CLK high or low	5		5		5		ns
t_{su}	Setup time, data before CLK \uparrow	3		3		3.5		ns
t_h	Hold time, data after CLK \uparrow	2		2		2.5		ns

6.10 Noise Characteristics

$V_{CC} = 3.3\text{ V}$, $C_L = 50\text{ pF}$, $T_A = 25^\circ\text{C}$ ⁽¹⁾

PARAMETER		SN74LV374A			UNIT
		MIN	TYP	MAX	
$V_{OL(P)}$	Quiet output, maximum dynamic V_{OL}		0.6	0.8	V
$V_{OL(V)}$	Quiet output, minimum dynamic V_{OL}		-0.5	-0.8	V
$V_{OH(V)}$	Quiet output, minimum dynamic V_{OH}	2.9	2.9		V
$V_{IH(D)}$	High-level dynamic input voltage	2.31			V
$V_{IL(D)}$	Low-level dynamic input voltage			0.99	V

(1) Characteristics are for surface-mount packages only.

6.11 Operating Characteristics, $T_A = 25^\circ\text{C}$

PARAMETER			TEST CONDITIONS	V_{CC}	TYP	UNIT
C_{pd}	Power dissipation capacitance	Outputs enabled	$C_L = 50\text{ pF}$, $f = 10\text{ MHz}$	3.3 V	21.1	pF
				5 V	22.8	

6.12 Typical Characteristics

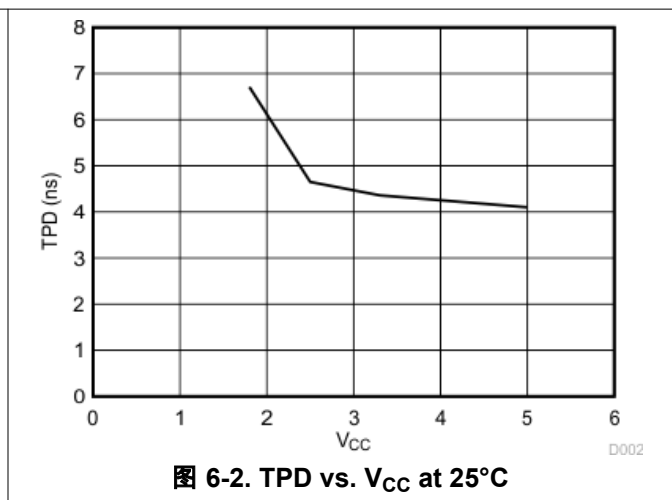
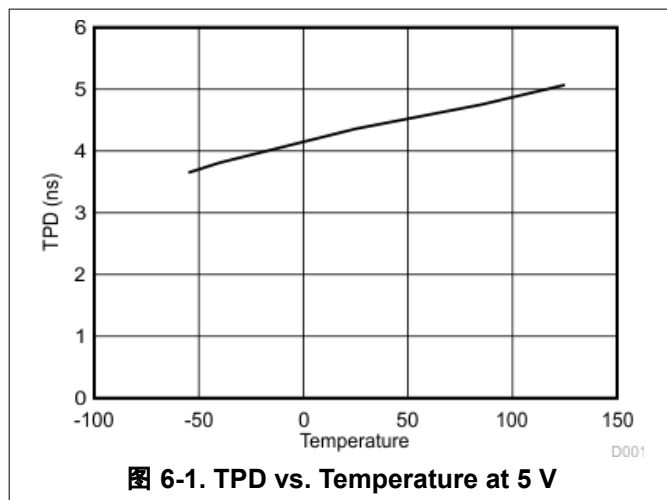

7 Parameter Measurement Information

7.1

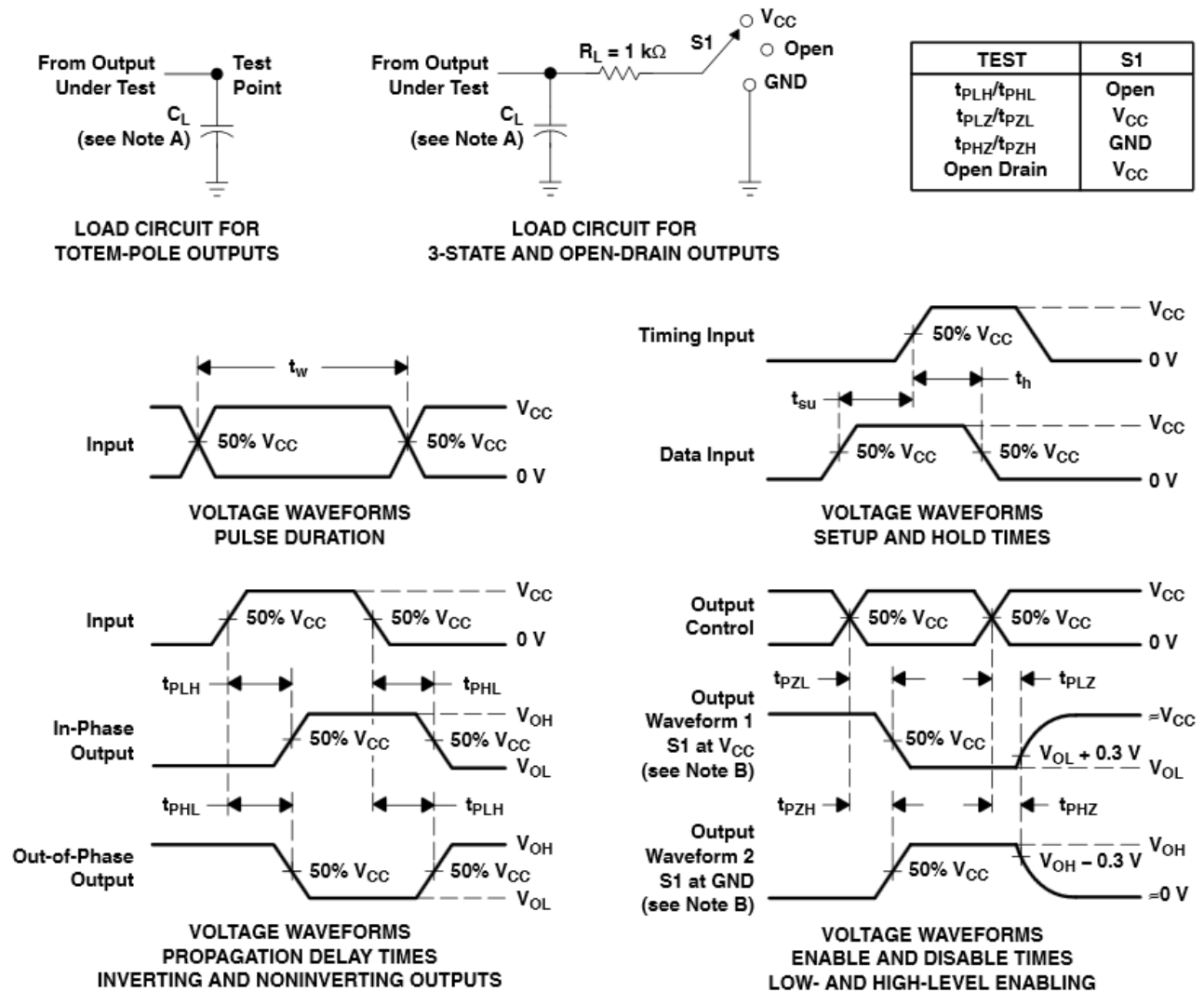

- NOTES:
- A. C_L includes probe and jig capacitance.
 - B. Waveform 1 is for an output with internal conditions such that the output is low, except when disabled by the output control. Waveform 2 is for an output with internal conditions such that the output is high, except when disabled by the output control.
 - C. All input pulses are supplied by generators having the following characteristics: $PRR \leq 1$ MHz, $Z_O = 50 \Omega$, $t_r \leq 3$ ns, $t_f \leq 3$ ns.
 - D. The outputs are measured one at a time, with one input transition per measurement.
 - E. t_{PLZ} and t_{PHZ} are the same as t_{dis} .
 - F. t_{PZL} and t_{PZH} are the same as t_{en} .
 - G. t_{PHL} and t_{PLH} are the same as t_{pd} .
 - H. All parameters and waveforms are not applicable to all devices.

图 7-1. Load Circuit and Voltage Waveforms

8 Detailed Description

8.1 Overview

The SN74LV374A devices are octal edge-triggered D-type flip-flops designed for 2 V to 5.5 V V_{CC} operation. These devices feature 3-state outputs designed specifically for driving highly capacitive or relatively low-impedance loads. They are particularly suitable for implementing buffer registers, I/O ports, bi-directional bus drivers, and working registers. On the positive transition of the clock (CLK) input, the Q outputs are set to the logic levels set up at the data (D) inputs. A buffered output-enable (\overline{OE}) input can be used to place the eight outputs in either a normal logic state (high or low logic levels) or high-impedance state. In the high-impedance state, the outputs neither load nor drive the bus lines significantly. The high-impedance state and the increased drive provide the capability to drive bus lines without need for interface or pullup components. \overline{OE} does not affect internal operations of the latch. Old data can be retained or new data can be entered while the outputs are in the high-impedance state. To ensure the high-impedance state during power up or power down, \overline{OE} should be tied to V_{CC} through a pullup resistor; the minimum value of the resistor is determined by the current-sinking capability of the driver. These devices are fully specified for partial-power-down applications using Ioff. The Ioff circuitry disables the outputs, preventing damaging current backflow through the devices when they are powered down. The output of the device is unknown until the first valid rising clock edge occurs while V_{CC} is within the [# 6.3](#) range.

8.2 Functional Block Diagram



图 8-1. Logic Diagram (Positive Logic)

8.3 Feature Description

The device's wide operating range allows it to be used in a variety of systems that use different logic levels. The low propagation delay allows fast switching and higher speeds of operation. In addition, the low ground bounce stabilizes the performance of non-switching outputs while another output is switching.

8.4 Device Functional Modes

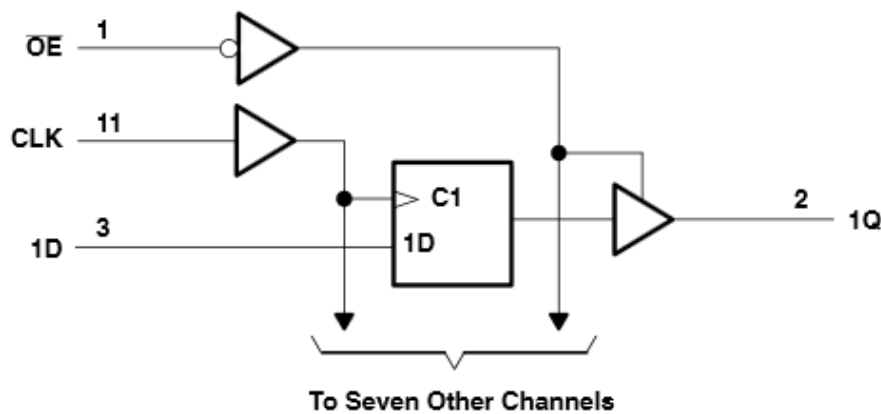
表 8-1 lists the functional modes of the SN74LV374A devices.

表 8-1. Function Table (Each Flip-Flop)

INPUTS			OUTPUT Q
\overline{OE}	CLK	D	
L	↑	H	H
L	↑	L	L
L	L	X	Q_0
H	X	X	Z

Application and Implementation

备注

Information in the following applications sections is not part of the TI component specification, and TI does not warrant its accuracy or completeness. TI's customers are responsible for determining suitability of components for their purposes. Customers should validate and test their design implementation to confirm system functionality.

9.1 Application Information

The SN74LV374A is a low drive CMOS device that can be used for a multitude of bus interface type applications where output ringing is a concern. The low drive and slow edge rates will minimize overshoot and undershoot on the outputs. The inputs accept voltages up to 5.5 V allowing down translation to the V_{CC} level.

9.2 Typical Application

图 9-1 shows how the slower edges can reduce ringing on the output compared to higher drive parts like AC.



图 9-1. Typical Application Schematic

9.2.1 Design Requirements

This device uses CMOS technology and has balanced output drive. Take care to avoid bus contention because it can drive currents that would exceed maximum limits. The high drive will also create fast edges into light loads so consider routing and load conditions to prevent ringing.

9.2.2 Detailed Design Procedure

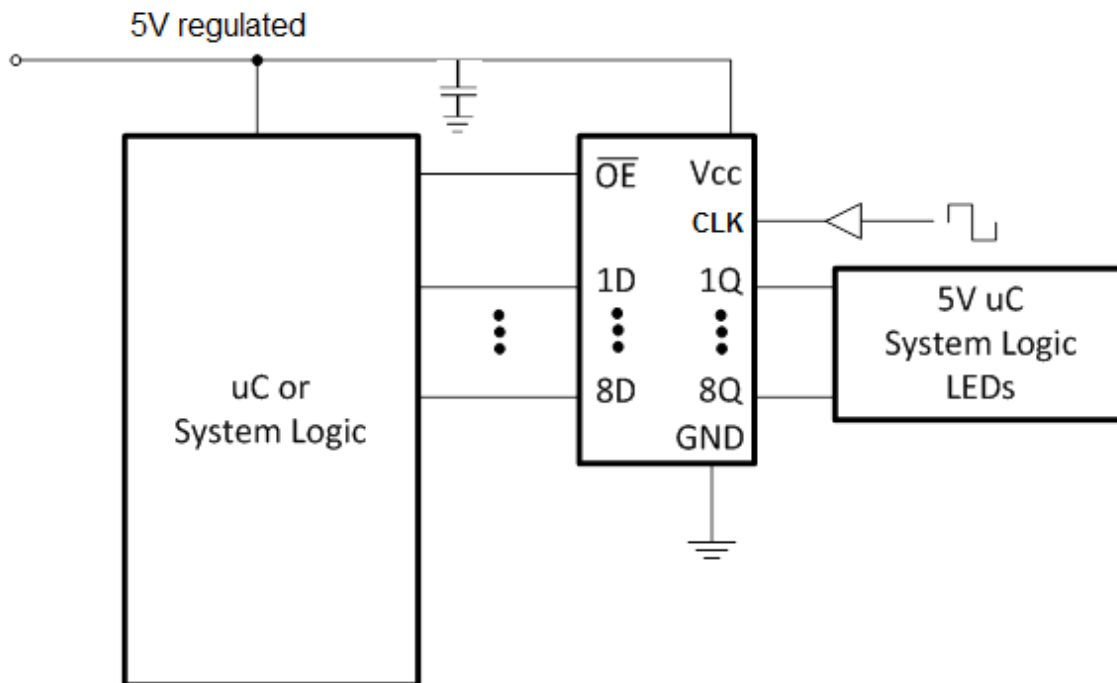
- Recommended Input conditions:
 - Rise time and fall time specs see $(\Delta t/\Delta V)$ in [# 6.3](#).
 - Specified High and low levels. See $(V_{IH}$ and $V_{IL})$ in [# 6.3](#).
 - Inputs are overvoltage tolerant allowing them to go as high as 5.5 V at any valid V_{CC} .
- Recommended output conditions:
 - Load currents should not exceed 35 mA per output and 70 mA total for the part.
 - Outputs should not be pulled above V_{CC} .

9.2.3 Application Curve



图 9-2. Switching Characteristics Comparison

9 Power Supply Recommendations

9.1

The power supply can be any voltage between the MIN and MAX supply voltage rating located in the [# 6.3](#). Each V_{CC} terminal should have a good bypass capacitor to prevent power disturbance. For devices with a single supply, TI recommends a 0.1- μF capacitor and if there are multiple V_{CC} terminals then TI recommends a 0.01- μF or 0.022- μF capacitor for each power terminal. Multiple bypass capacitors can be paralleled to reject different frequencies of noise. Frequencies of 0.1 μF and 1 μF are commonly used in parallel. The bypass capacitor should be installed as close as possible to the power terminal for best results.

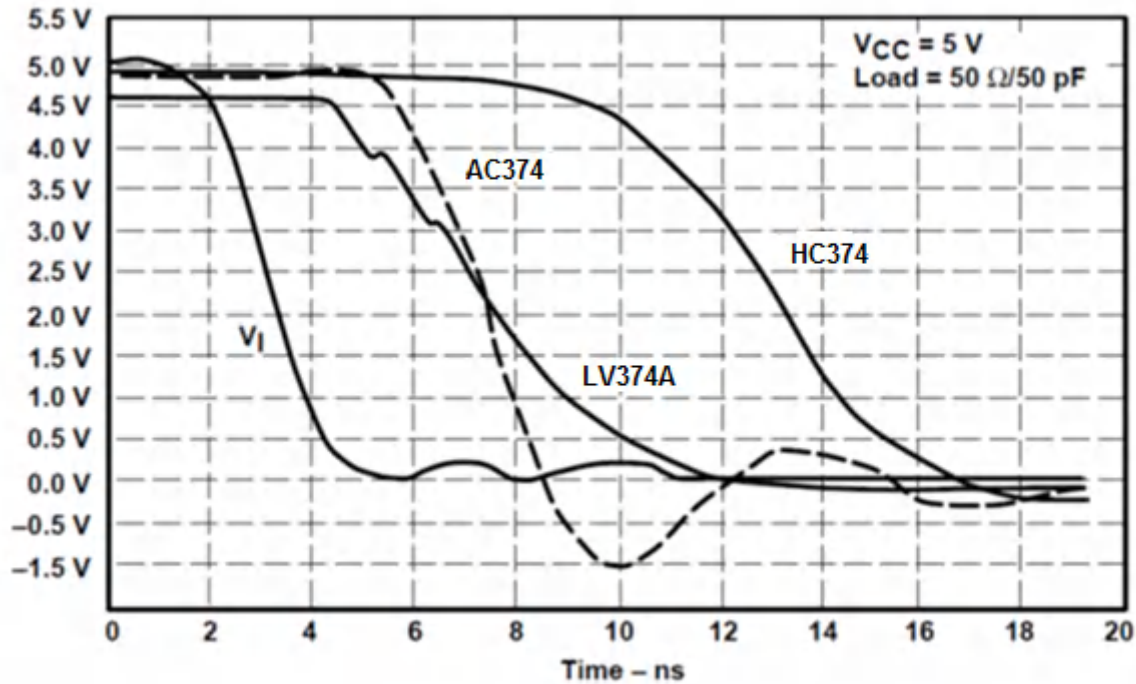
10 Layout

10.1 Layout Guidelines

When using multiple bit logic devices inputs should not ever float. In many cases, functions or parts of functions of digital logic devices are unused, for example, when only two inputs of a triple-input AND gate are used or only three of the four buffer gates are used. Such input pins should not be left unconnected because the undefined voltages at the outside connections result in undefined operational states. Specified below are the rules that must be observed under all circumstances. All unused inputs of digital logic devices must be connected to a high or low bias to prevent them from floating. The logic level that should be applied to any particular unused input depends on the function of the device. Generally they will be tied to GND or V_{CC} whichever make more sense or is more convenient. Floating outputs is generally acceptable, unless the part is a transceiver. If the transceiver has an output enable pin it will disable the outputs section of the part when asserted. This will not disable the input section of the I.O's so they also cannot float when disabled.

10.2 Layout Example



图 10-1. Layout Example

11 Device and Documentation Support

11.1 Documentation Support

11.1.1 Related Documentation

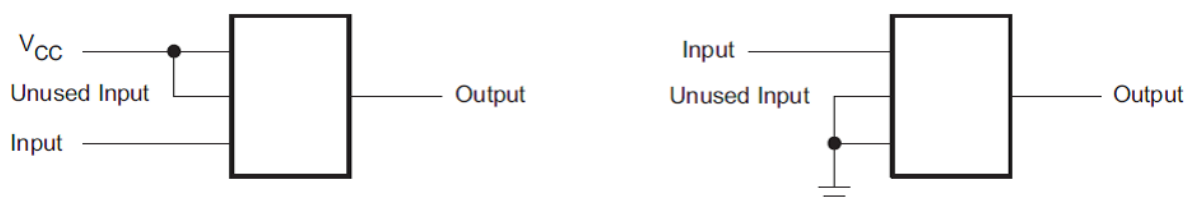
For related documentation see the following:

[Implications of Slow or Floating CMOS Inputs](#), SCBA004

11.2 Related Links

The table below lists quick access links. Categories include technical documents, support and community resources, tools and software, and quick access to sample or buy.

表 11-1. Related Links

PARTS	PRODUCT FOLDER	SAMPLE & BUY	TECHNICAL DOCUMENTS	TOOLS & SOFTWARE	SUPPORT & COMMUNITY
SN74LV374A	Click here	Click here	Click here	Click here	Click here

11.3 Receiving Notification of Documentation Updates

To receive notification of documentation updates, navigate to the device product folder on ti.com. In the upper right corner, click on *Alert me* to register and receive a weekly digest of any product information that has changed. For change details, review the revision history included in any revised document.

11.4 Community Resources

11.5 Trademarks

所有商标均为其各自所有者的财产。

Mechanical, Packaging, and Orderable Information

The following pages include mechanical, packaging, and orderable information. This information is the most current data available for the designated devices. This data is subject to change without notice and revision of this document. For browser-based versions of this data sheet, refer to the left-hand navigation.

PACKAGING INFORMATION

Orderable Device	Status (1)	Package Type	Package Drawing	Pins	Package Qty	Eco Plan (2)	Lead finish/ Ball material (6)	MSL Peak Temp (3)	Op Temp (°C)	Device Marking (4/5)	Samples
SN74LV374ADBR	ACTIVE	SSOP	DB	20	2000	RoHS & Green	NIPDAU	Level-1-260C-UNLIM	-40 to 125	LV374A	Samples
SN74LV374ADW	ACTIVE	SOIC	DW	20	25	RoHS & Green	NIPDAU	Level-1-260C-UNLIM	-40 to 125	LV374A	Samples
SN74LV374ADWG4	ACTIVE	SOIC	DW	20	25	RoHS & Green	NIPDAU	Level-1-260C-UNLIM	-40 to 125	LV374A	Samples
SN74LV374ADWR	ACTIVE	SOIC	DW	20	2000	RoHS & Green	NIPDAU	Level-1-260C-UNLIM	-40 to 125	LV374A	Samples
SN74LV374ANSR	ACTIVE	SO	NS	20	2000	RoHS & Green	NIPDAU	Level-1-260C-UNLIM	-40 to 125	74LV374A	Samples
SN74LV374APW	ACTIVE	TSSOP	PW	20	70	RoHS & Green	NIPDAU	Level-1-260C-UNLIM	-40 to 125	LV374A	Samples
SN74LV374APWR	ACTIVE	TSSOP	PW	20	2000	RoHS & Green	NIPDAU	Level-1-260C-UNLIM	-40 to 125	LV374A	Samples

(1) The marketing status values are defined as follows:

ACTIVE: Product device recommended for new designs.

LIFEBUY: TI has announced that the device will be discontinued, and a lifetime-buy period is in effect.

NRND: Not recommended for new designs. Device is in production to support existing customers, but TI does not recommend using this part in a new design.

PREVIEW: Device has been announced but is not in production. Samples may or may not be available.

OBSOLETE: TI has discontinued the production of the device.

(2) **RoHS:** TI defines "RoHS" to mean semiconductor products that are compliant with the current EU RoHS requirements for all 10 RoHS substances, including the requirement that RoHS substance do not exceed 0.1% by weight in homogeneous materials. Where designed to be soldered at high temperatures, "RoHS" products are suitable for use in specified lead-free processes. TI may reference these types of products as "Pb-Free".

RoHS Exempt: TI defines "RoHS Exempt" to mean products that contain lead but are compliant with EU RoHS pursuant to a specific EU RoHS exemption.

Green: TI defines "Green" to mean the content of Chlorine (Cl) and Bromine (Br) based flame retardants meet JS709B low halogen requirements of <=1000ppm threshold. Antimony trioxide based flame retardants must also meet the <=1000ppm threshold requirement.

(3) MSL, Peak Temp. - The Moisture Sensitivity Level rating according to the JEDEC industry standard classifications, and peak solder temperature.

(4) There may be additional marking, which relates to the logo, the lot trace code information, or the environmental category on the device.

(5) Multiple Device Markings will be inside parentheses. Only one Device Marking contained in parentheses and separated by a "~" will appear on a device. If a line is indented then it is a continuation of the previous line and the two combined represent the entire Device Marking for that device.

(6) Lead finish/Ball material - Orderable Devices may have multiple material finish options. Finish options are separated by a vertical ruled line. Lead finish/Ball material values may wrap to two lines if the finish value exceeds the maximum column width.

Important Information and Disclaimer:The information provided on this page represents TI's knowledge and belief as of the date that it is provided. TI bases its knowledge and belief on information provided by third parties, and makes no representation or warranty as to the accuracy of such information. Efforts are underway to better integrate information from third parties. TI has taken and continues to take reasonable steps to provide representative and accurate information but may not have conducted destructive testing or chemical analysis on incoming materials and chemicals. TI and TI suppliers consider certain information to be proprietary, and thus CAS numbers and other limited information may not be available for release.

In no event shall TI's liability arising out of such information exceed the total purchase price of the TI part(s) at issue in this document sold by TI to Customer on an annual basis.

OTHER QUALIFIED VERSIONS OF SN74LV374A :

- Automotive : [SN74LV374A-Q1](#)
- Enhanced Product : [SN74LV374A-EP](#)

NOTE: Qualified Version Definitions:

- Automotive - Q100 devices qualified for high-reliability automotive applications targeting zero defects
- Enhanced Product - Supports Defense, Aerospace and Medical Applications

TAPE AND REEL INFORMATION

QUADRANT ASSIGNMENTS FOR PIN 1 ORIENTATION IN TAPE

*All dimensions are nominal

Device	Package Type	Package Drawing	Pins	SPQ	Reel Diameter (mm)	Reel Width W1 (mm)	A0 (mm)	B0 (mm)	K0 (mm)	P1 (mm)	W (mm)	Pin1 Quadrant
SN74LV374ADBR	SSOP	DB	20	2000	330.0	16.4	8.2	7.5	2.5	12.0	16.0	Q1
SN74LV374ADWR	SOIC	DW	20	2000	330.0	24.4	10.8	13.3	2.7	12.0	24.0	Q1
SN74LV374ANSR	SO	NS	20	2000	330.0	24.4	8.4	13.0	2.5	12.0	24.0	Q1
SN74LV374APWR	TSSOP	PW	20	2000	330.0	16.4	6.95	7.0	1.4	8.0	16.0	Q1

TAPE AND REEL BOX DIMENSIONS

*All dimensions are nominal

Device	Package Type	Package Drawing	Pins	SPQ	Length (mm)	Width (mm)	Height (mm)
SN74LV374ADBR	SSOP	DB	20	2000	356.0	356.0	35.0
SN74LV374ADWR	SOIC	DW	20	2000	367.0	367.0	45.0
SN74LV374ANSR	SO	NS	20	2000	367.0	367.0	45.0
SN74LV374APWR	TSSOP	PW	20	2000	356.0	356.0	35.0

TUBE

*All dimensions are nominal

Device	Package Name	Package Type	Pins	SPQ	L (mm)	W (mm)	T (μm)	B (mm)
SN74LV374ADW	DW	SOIC	20	25	507	12.83	5080	6.6
SN74LV374ADWG4	DW	SOIC	20	25	507	12.83	5080	6.6
SN74LV374APW	PW	TSSOP	20	70	530	10.2	3600	3.5

DB0020A



PACKAGE OUTLINE

SSOP - 2 mm max height

SMALL OUTLINE PACKAGE



4214851/B 08/2019

EXAMPLE BOARD LAYOUT

DB0020A

SSOP - 2 mm max height

SMALL OUTLINE PACKAGE



LAND PATTERN EXAMPLE
EXPOSED METAL SHOWN
SCALE: 10X



4214851/B 08/2019

NOTES: (continued)

- 6. Publication IPC-7351 may have alternate designs.
- 7. Solder mask tolerances between and around signal pads can vary based on board fabrication site.

EXAMPLE STENCIL DESIGN

DB0020A

SSOP - 2 mm max height

SMALL OUTLINE PACKAGE



SOLDER PASTE EXAMPLE
BASED ON 0.125 mm THICK STENCIL
SCALE: 10X

4214851/B 08/2019

NOTES: (continued)

8. Laser cutting apertures with trapezoidal walls and rounded corners may offer better paste release. IPC-7525 may have alternate design recommendations.
9. Board assembly site may have different recommendations for stencil design.

MECHANICAL DATA

NS (R-PDSO-G**)

PLASTIC SMALL-OUTLINE PACKAGE

14-PINS SHOWN



- NOTES:
- A. All linear dimensions are in millimeters.
 - B. This drawing is subject to change without notice.
 - C. Body dimensions do not include mold flash or protrusion, not to exceed 0,15.

DW0020A



PACKAGE OUTLINE

SOIC - 2.65 mm max height

SOIC



4220724/A 05/2016

NOTES:

1. All linear dimensions are in millimeters. Dimensions in parenthesis are for reference only. Dimensioning and tolerancing per ASME Y14.5M.
2. This drawing is subject to change without notice.
3. This dimension does not include mold flash, protrusions, or gate burrs. Mold flash, protrusions, or gate burrs shall not exceed 0.15 mm per side.
4. This dimension does not include interlead flash. Interlead flash shall not exceed 0.43 mm per side.
5. Reference JEDEC registration MS-013.

EXAMPLE BOARD LAYOUT

DW0020A

SOIC - 2.65 mm max height

SOIC



LAND PATTERN EXAMPLE
SCALE:6X



SOLDER MASK DETAILS

4220724/A 05/2016

NOTES: (continued)

- 6. Publication IPC-7351 may have alternate designs.
- 7. Solder mask tolerances between and around signal pads can vary based on board fabrication site.

EXAMPLE STENCIL DESIGN

DW0020A

SOIC - 2.65 mm max height

SOIC



SOLDER PASTE EXAMPLE
BASED ON 0.125 mm THICK STENCIL
SCALE:6X

4220724/A 05/2016

NOTES: (continued)

8. Laser cutting apertures with trapezoidal walls and rounded corners may offer better paste release. IPC-7525 may have alternate design recommendations.
9. Board assembly site may have different recommendations for stencil design.

PW0020A

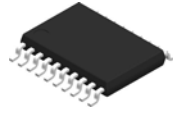

PACKAGE OUTLINE TSSOP - 1.2 mm max height

SMALL OUTLINE PACKAGE

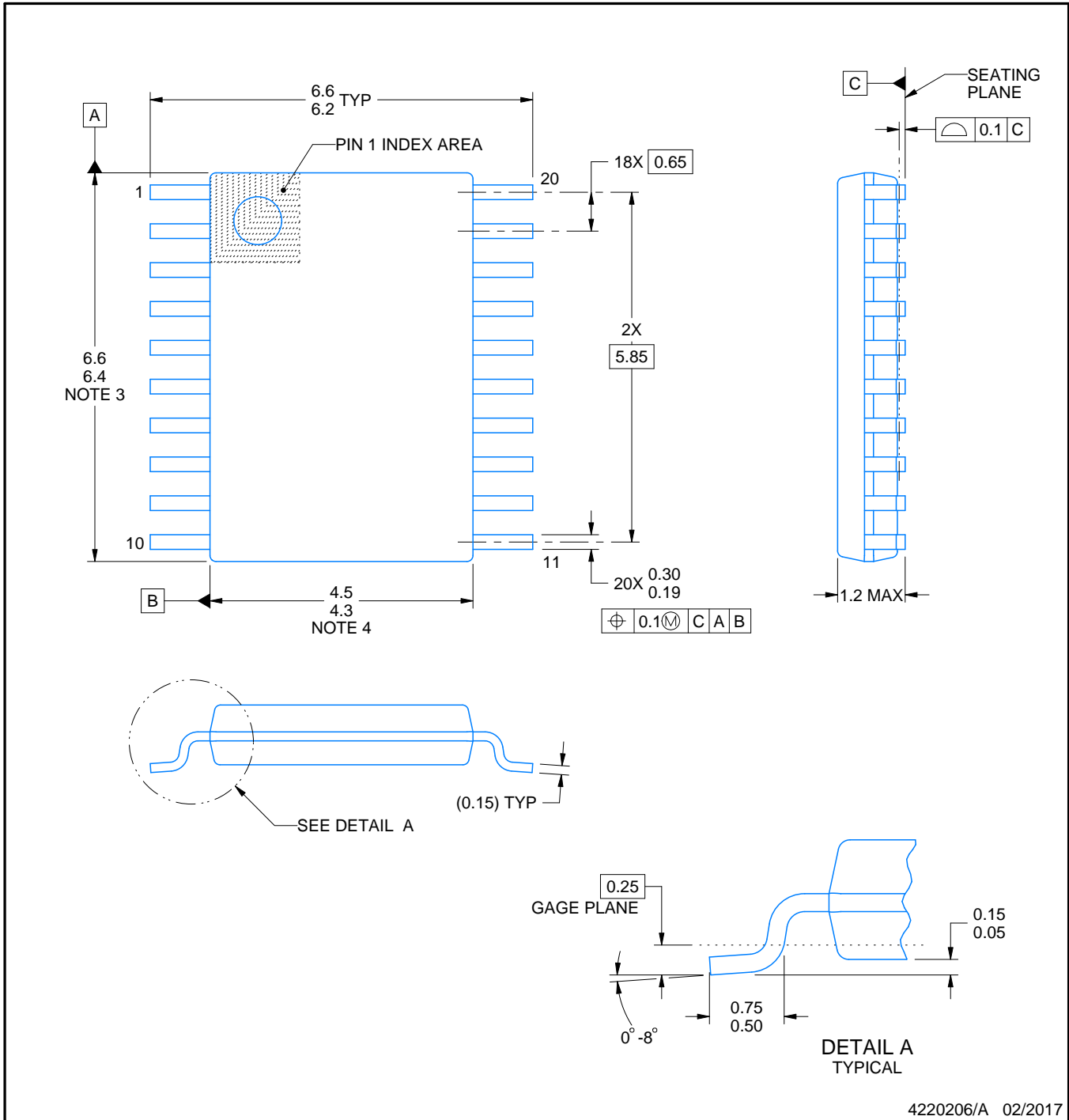

NOTES:

1. All linear dimensions are in millimeters. Any dimensions in parenthesis are for reference only. Dimensioning and tolerancing per ASME Y14.5M.
2. This drawing is subject to change without notice.
3. This dimension does not include mold flash, protrusions, or gate burrs. Mold flash, protrusions, or gate burrs shall not exceed 0.15 mm per side.
4. This dimension does not include interlead flash. Interlead flash shall not exceed 0.25 mm per side.
5. Reference JEDEC registration MO-153.

EXAMPLE BOARD LAYOUT

PW0020A

TSSOP - 1.2 mm max height

SMALL OUTLINE PACKAGE



LAND PATTERN EXAMPLE
EXPOSED METAL SHOWN
SCALE: 10X



SOLDER MASK DETAILS

4220206/A 02/2017

NOTES: (continued)

- 6. Publication IPC-7351 may have alternate designs.
- 7. Solder mask tolerances between and around signal pads can vary based on board fabrication site.

EXAMPLE STENCIL DESIGN

PW0020A

TSSOP - 1.2 mm max height

SMALL OUTLINE PACKAGE



SOLDER PASTE EXAMPLE
BASED ON 0.125 mm THICK STENCIL
SCALE: 10X

4220206/A 02/2017

NOTES: (continued)

8. Laser cutting apertures with trapezoidal walls and rounded corners may offer better paste release. IPC-7525 may have alternate design recommendations.
9. Board assembly site may have different recommendations for stencil design.

重要声明和免责声明

TI“按原样”提供技术和可靠性数据（包括数据表）、设计资源（包括参考设计）、应用或其他设计建议、网络工具、安全信息和其他资源，不保证没有瑕疵且不做任何明示或暗示的担保，包括但不限于对适销性、某特定用途方面的适用性或不侵犯任何第三方知识产权的暗示担保。

这些资源可供使用 TI 产品进行设计的熟练开发人员使用。您将自行承担以下全部责任：(1) 针对您的应用选择合适的 TI 产品，(2) 设计、验证并测试您的应用，(3) 确保您的应用满足相应标准以及任何其他功能安全、信息安全、监管或其他要求。

这些资源如有变更，恕不另行通知。TI 授权您仅可将这些资源用于研发本资源所述的 TI 产品的应用。严禁对这些资源进行其他复制或展示。您无权使用任何其他 TI 知识产权或任何第三方知识产权。您应全额赔偿因在这些资源的使用中对 TI 及其代表造成的任何索赔、损害、成本、损失和债务，TI 对此概不负责。

TI 提供的产品受 [TI 的销售条款](#) 或 [ti.com](#) 上其他适用条款/TI 产品随附的其他适用条款的约束。TI 提供这些资源并不会扩展或以其他方式更改 TI 针对 TI 产品发布的适用的担保或担保免责声明。

TI 反对并拒绝您可能提出的任何其他或不同的条款。

邮寄地址：Texas Instruments, Post Office Box 655303, Dallas, Texas 75265

Copyright © 2023，德州仪器 (TI) 公司