

# MSP432E411Y SimpleLink™ 以太网微控制器

## 1 器件概述

### 1.1 特性

- 内核
  - 120MHz ARM® Cortex®- 具有浮点运算单元 (FPU) 的 M4F 处理器内核
- 连接
  - 以太网 MAC: 10/100 以太网 MAC 带媒体独立接口 (MII) 和简化媒体独立接口 (RMII)
  - 以太网 PHY: 具有 IEEE 1588 PTP 硬件支持的 PHY
  - 通用串行总线 (USB): 具有 ULPI 接口选项和链路层电源管理 (LPM) 的 USB 2.0 OTG、主机或器件
  - 8 个通用异步接收器/发射器 (UART), 每个具有独立计时的发送器和接收器
  - 4 个四通道同步串行接口 (QSSI): 提供双通道、四通道和高级 SSI 支持
  - 提供高速模式支持的 10 个内部集成电路 (I<sup>2</sup>C) 模块
  - 2 个 CAN 2.0 A 和 B 控制器: 多播共享串行总线标准
  - 1 个具有双向串行通信协议的单线制模块通过一条单线提供电源和数据
- 存储器
  - 具有 4 个存储体的 1024KB 闪存存储器配置支持对每个存储体提供独立代码保护
  - 具有单周期访问的 256KB SRAM 以 120MHz 时钟频率提供近 2GB/s 的内存带宽
  - 6KB EEPROM: 每 2 个页块写入 500k、矫正、锁定保护
  - 内部 ROM: 搭载有 SimpleLink™ SDK 软件
    - 外设驱动程序库
    - 引导加载程序
  - 外部外设接口 (EPI): 8、16 或 32 位专用并行接口访问外部器件和存储器 (SDRAM、闪存或 SRAM)
- 安全性
  - 高级加密标准 (AES): 基于 128、192 和 256 位密钥的硬件加速数据加密和解密
  - 数据加密标准 (DES): 具有 168 位有效密钥长度并且支持块密码实施的硬件加速数据加密和解密
  - 安全哈希算法/消息摘要算法 (SHA/MD5): 支持 SHA-1、SHA-2 和 MD5 哈希计算的高级哈希引擎
  - 循环冗余校验 (CRC) 硬件
  - 篡改: 支持四个篡改输入和可配置篡改事件响应
- 模拟
  - 2 个基于 12 位 SAR 的 ADC 模块, 每个模块支持高达 200 万次/秒的采样率 (2Msps)
  - 3 个独立的模拟比较器控制器
  - 16 个数字比较器
- 系统管理
  - JTAG 和串行线调试 (SWD): 一个具有集成 ARM SWD 的 JTAG 模块提供访问和控制测试设计特性的途径, 如 I/O 引脚监督和控制、扫描测试和调试。
- 开发套件和软件 (请参阅 [工具和软件](#))
  - SimpleLink™ MSP-EXP432E401Y LaunchPad™ 开发套件
  - SimpleLink MSP432E4 软件开发套件 (SDK)
- 封装信息
  - 封装: 212 焊球 NFBGA (ZAD)
  - 扩展工作温度 (环境) 范围: -40°C 至 105°C

### 1.2 应用

- 工业以太网网关
- 工业智能网关
- 适用于楼宇自动化的区域控制器
- 工厂自动化数据收集器和网关
- 面向电网基础设施的数据集中器
- 无线转以太网网关

### 1.3 说明

SimpleLink MSP432E411Y ARM® Cortex®-M4F 微控制器具有顶级性能和高级集成功能。该产品系列用于需要强大的控制处理和连接功能且具有成本效益的应用。



MSP432E411Y 微控制器集成了大量丰富的通信特性，以实现全新的高度互连设计，在性能和功耗之间实现重要的实时控制。这些微控制器具有集成式通信外设以及其他高性能的模拟和数字功能，为开发从人机界面 (HMI) 到联网系统管理控制器在内的许多不同目标应用奠定了坚实的基础。

此外，MSP432E411Y 微控制器为基于 ARM 的微控制器提供了诸多优势，如广泛可用的开发工具、片上系统 (SoC) 基础架构，以及一个庞大的用户社区。另外，这些微控制器使用 ARM Thumb®兼容的 Thumb-2® 指令集来减少内存要求，并以此达到降低成本的目的。当使用 SimpleLink MSP432™SDK 时，MSP432E411Y 与 SimpleLink 系列的所有成员的代码兼容，因此使用灵活，可满足各类具体需求。

MSP432E411Y 器件是 SimpleLink 微控制器 (MCU) 平台的一部分，该平台包含 Wi-Fi®、低功耗 Bluetooth®、低于 1GHz、以太网、Zigbee、线程和主机 MCU，它们均共用一个通用、简单易用的开发环境，其中包含单核软件开发套件 (SDK) 和丰富的工具集。借助一次性集成的 SimpleLink 平台，可以将产品组合中的任何器件组合添加至您的设计中，从而在设计要求变更时实现 100% 代码重用。更多详细信息，请访问 [www.ti.com/simplelink](http://www.ti.com/simplelink)。

### Device Information<sup>(1)</sup>

PART NUMBER	PACKAGE	封装尺寸
MSP432E411YTZAD	NFBGA (212)	10mm x 10mm

(1) 更多信息，请参见 节 9，机械、封装和可订购产品信息。

### 1.4 功能框图

图 1-1 给出了功能框图。

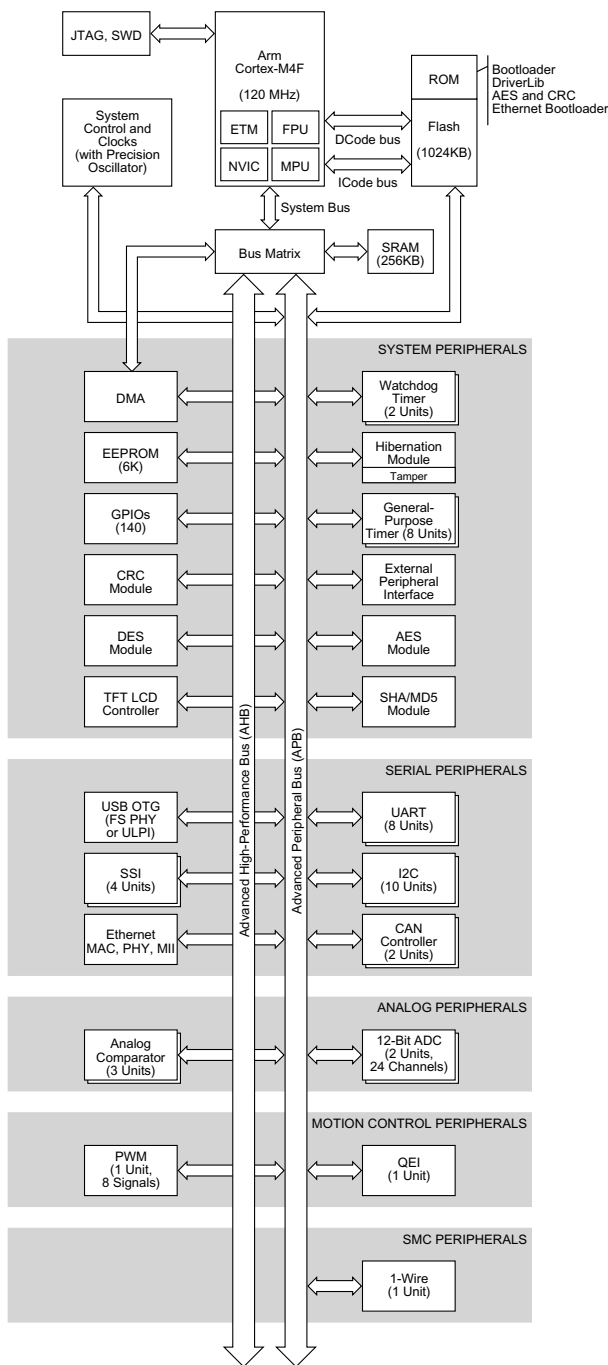

Copyright © 2017, Texas Instruments Incorporated

图 1-1. MSP432E411Y 功能方框图

## 内容

<b>1</b>	<b>器件概述</b> .....	<b><a href="#">1</a></b>	5.11	Peripheral Current Consumption .....	<a href="#">58</a>
1.1	特性 .....	<a href="#">1</a>	5.12	LDO Regulator Characteristics .....	<a href="#">58</a>
1.2	应用 .....	<a href="#">1</a>	5.13	Power Dissipation .....	<a href="#">59</a>
1.3	说明 .....	<a href="#">1</a>	5.14	Thermal Resistance Characteristics, 212-Pin ZAD (NFBGA) Package .....	<a href="#">59</a>
1.4	功能框图 .....	<a href="#">3</a>	5.15	Timing and Switching Characteristics .....	<a href="#">60</a>
<b>2</b>	<b>Revision History</b> .....	<b><a href="#">5</a></b>	<b>6</b>	<b>Detailed Description</b> .....	<b><a href="#">130</a></b>
<b>3</b>	<b>Device Characteristics</b> .....	<b><a href="#">6</a></b>	6.1	Overview .....	<a href="#">130</a>
3.1	Related Products .....	<a href="#">7</a>	6.2	Functional Block Diagram .....	<a href="#">131</a>
<b>4</b>	<b>Terminal Configuration and Functions</b> .....	<b><a href="#">8</a></b>	6.3	Arm Cortex-M4F Processor Core .....	<a href="#">132</a>
4.1	Pin Diagram .....	<a href="#">8</a>	6.4	On-Chip Memory .....	<a href="#">136</a>
4.2	Pin Attributes .....	<a href="#">9</a>	6.5	Peripherals .....	<a href="#">138</a>
4.3	Signal Descriptions .....	<a href="#">25</a>	6.6	Identification .....	<a href="#">181</a>
4.4	GPIO Pin Multiplexing .....	<a href="#">45</a>	6.7	Boot Modes .....	<a href="#">182</a>
4.5	Buffer Type .....	<a href="#">50</a>	<b>7</b>	<b>Applications, Implementation, and Layout</b> .....	<b><a href="#">183</a></b>
4.6	Connections for Unused Pins .....	<a href="#">50</a>	7.1	System Design Guidelines .....	<a href="#">183</a>
<b>5</b>	<b>Specifications</b> .....	<b><a href="#">52</a></b>	<b>8</b>	<b>器件和文档支持</b> .....	<b><a href="#">184</a></b>
5.1	Absolute Maximum Ratings .....	<a href="#">52</a>	8.1	入门和后续步骤 .....	<a href="#">184</a>
5.2	ESD Ratings .....	<a href="#">52</a>	8.2	器件命名规则 .....	<a href="#">184</a>
5.3	Recommended Operating Conditions .....	<a href="#">52</a>	8.3	工具和软件 .....	<a href="#">185</a>
5.4	Recommended DC Operating Conditions .....	<a href="#">52</a>	8.4	文档支持 .....	<a href="#">186</a>
5.5	Recommended GPIO Operating Characteristics ...	<a href="#">52</a>	8.5	Community Resources .....	<a href="#">187</a>
5.6	Recommended Fast GPIO Pad Operating Conditions .....	<a href="#">53</a>	8.6	商标 .....	<a href="#">187</a>
5.7	Recommended Slow GPIO Pad Operating Conditions .....	<a href="#">53</a>	8.7	静电放电警告 .....	<a href="#">187</a>
5.8	GPIO Current Restrictions .....	<a href="#">54</a>	8.8	出口管制提示 .....	<a href="#">187</a>
5.9	I/O Reliability .....	<a href="#">54</a>	8.9	术语表 .....	<a href="#">187</a>
5.10	Current Consumption .....	<a href="#">55</a>	<b>9</b>	<b>机械、封装和可订购信息</b> .....	<b><a href="#">188</a></b>

## 2 Revision History

注：之前版本的页码可能与当前版本有所不同。

DATE	REVISION	NOTES
2017 年 10 月	*	初始发行版

### 3 Device Characteristics

表 3-1 lists the characteristics of the MSP432E411Y MCU.

表 3-1. Device Characteristics

Feature	Description
<b>Performance</b>	
Core	Arm Cortex-M4F processor core
Performance	120-MHz operation, 150-DMIPS performance
Flash	1024KB of flash memory
System SRAM	256KB of single-cycle system SRAM
EEPROM	6KB of EEPROM
Internal ROM	Internal ROM loaded with SimpleLink SDK software
External Peripheral Interface (EPI)	8-, 16-, or 32-bit dedicated interface for peripherals and memory
<b>Security</b>	
Cyclical Redundancy Check (CRC)	16- or 32-bit hash function that supports four CRC forms
Advanced Encryption Standard (AES)	Hardware accelerated data encryption and decryption based on 128-, 192-, and 256-bit keys
Data Encryption Standard (DES)	Block cipher implementation with 168-bit effective key length
Hardware Accelerated Hash (SHA/MD5)	Advanced hash engine that supports SHA-1, SHA-2, or MD5 hash computation
Tamper	Support for four tamper inputs and configurable tamper event response
<b>Communication Interfaces</b>	
Universal Asynchronous Receiver/Transmitter (UART)	Eight UARTs
Quad Synchronous Serial Interface (QSSI)	Four SSI modules with bi-, quad-, and advanced-SSI support
Inter-Integrated Circuit (I <sup>2</sup> C)	Ten I <sup>2</sup> C modules with four transmission speeds including high-speed mode
Controller Area Network (CAN)	Two CAN 2.0 A/B controllers
Ethernet MAC	10/100 Ethernet MAC with Media Independent Interface (MII) and Reduced MII (RMII)
Ethernet PHY	PHY with IEEE 1588 PTP hardware support
Universal Serial Bus (USB)	USB 2.0 OTG, Host, and Device with ULPI interface option and Link Power Management (LPM) support
1-Wire	One 1-Wire module
<b>System Integration</b>	
Micro Direct Memory Access (μDMA)	Arm PrimeCell <sup>®</sup> 32-channel configurable μDMA controller
LCD Controller	Configurable LCD controller with passive and active matrix LCD panel support
General-Purpose Timer (GPTM)	Eight 16- or 32-bit GPTM blocks
Watchdog Timer (WDT)	Two watchdog timers
Hibernation Module (HIB)	Low-power battery-backed Hibernation module
General-Purpose Input/Output (GPIO)	18 physical GPIO blocks
<b>Advanced Motion Control</b>	
Pulse Width Modulator (PWM)	One PWM module, with four PWM generator blocks and a control block, for a total of 8 PWM outputs
Quadrature Encoder Interface (QEI)	One QEI module
<b>Analog Support</b>	
Analog-to-Digital Converter (ADC)	Two 12-bit ADC modules, each with a maximum sample rate of 2 Msps
Analog Comparator Controller	Three independent integrated analog comparators
Digital Comparator	16 digital comparators
<b>System Management</b>	
JTAG and Serial Wire Debug (SWD)	One JTAG module with integrated Arm SWD

**表 3-1. Device Characteristics (continued)**

Feature	Description
<b>Package Information</b>	
Package	212-ball NFBGA (ZAD)
Operating Range (Ambient)	Extended temperature range (–40°C to 105°C)

### 3.1 Related Products

For information about other devices in this family of products or related products, see the following links.

**Products for TI Microcontrollers** Low-power and high-performance MCUs, with wired and wireless connectivity options.

**Products for SimpleLink MSP432 MCUs** SimpleLink MSP432 MCUs with an ultra-low-power Arm Cortex-M4 core are optimized for Internet-of-Things sensor node applications. With an integrated ADC, the family enables acquisition and processing of high-precision signals without sacrificing power and is an optimal host MCU for TI's SimpleLink wireless connectivity solutions.

**Companion Products for MSP432E411Y** Review products that are frequently purchased or used with this product.

**Reference Designs** The TI Designs Reference Design Library is a robust reference design library that spans analog, embedded processor, and connectivity. Created by TI experts to help you jump start your system design, all TI Designs include schematic or block diagrams, BOMs, and design files to speed your time to market.





## 4.2 Pin Attributes

表 4-1 lists GPIO pins with special considerations. Most GPIO pins are configured as GPIOs and are high-impedance by default (GPIOAFSEL = 0, GPIODEN = 0, GPIOPDR = 0, GPIOPUR = 0, and GPIOCTL = 0). Special consideration pins may be programmed to a non-GPIO function or may have special commit controls out of reset. In addition, a POR returns these GPIOs to their original special consideration state.

表 4-1. GPIO Pins With Special Considerations

GPIO PINS	DEFAULT RESET STATE	GPIOAFSEL	GPIODEN	GPIOPDR	GPIOPUR	GPIOCTL	GPIOCR
PC[3:0]	JTAG/SWD	1	1	0	1	0x1	0
PD[7]	GPIO <sup>(1)</sup>	0	0	0	0	0x0	0
PE[7]	GPIO <sup>(1)</sup>	0	0	0	0	0x0	0

(1) This pin is configured as a GPIO by default but is locked and can only be reprogrammed by unlocking the pin in the GPIOLOCK register and uncommitting it by setting the GPIOCR register.

表 4-2 describes the pin attributes.

表 4-2. Pin Attributes

PIN NUMBER	SIGNAL NAME <sup>(1)</sup>	SIGNAL TYPE <sup>(2)</sup>	BUFFER TYPE <sup>(3)</sup>	PIN MUX ENCODING <sup>(4)</sup>	POWER SOURCE <sup>(5)</sup>	STATE AFTER RESET RELEASE <sup>(6)</sup>
A1	GND	–	Power	–	N/A	N/A
A2	GND	–	Power	–	N/A	N/A
A4	PD4	I/O	LVC MOS	–	VDD	OFF
	AIN7	I	Analog	PD4		N/A
	SSI1XDAT2	I/O	LVC MOS	PD4 (15)		N/A
	T3CCP0	I/O	LVC MOS	PD4 (3)		N/A
	U2Rx	I	LVC MOS	PD4 (1)		N/A
A5	PE4	I/O	LVC MOS	–	VDD	OFF
	AIN9	I	Analog	PE5		N/A
	SSI1XDAT0	I/O	LVC MOS	PE4 (15)		N/A
	U1RI	I	LVC MOS	PE4 (1)		N/A
A7	PE6	I/O	LVC MOS	–	VDD	OFF
	AIN20	I	Analog	PE6		N/A
	I2C9SCL	I/O	LVC MOS	PE6 (2)		N/A
	U0CTS	I	LVC MOS	PE6 (1)		N/A
A8	PP7	I/O	LVC MOS	–	VDD	OFF
	AIN22	I	Analog	PP7		N/A
	OWIRE	I/O	LVC MOS	PP7 (5)		N/A
A10	PN4	I/O	LVC MOS	–	VDD	OFF
	EPI0S34	I/O	LVC MOS	PN4 (15)		N/A
	I2C2SDA	I/O	LVC MOS	PN4 (3)		N/A
	U1DTR	O	LVC MOS	PN4 (1)		N/A
	U3RTS	O	LVC MOS	PN4 (2)		N/A

(1) Signals names with (PN) denote the default pin name.

(2) Signal Types: I = Input, O = Output, I/O = Input or Output.

(3) For details on buffer types, see 表 4-5.

(4) Pin mux encodings with (RD) denote the default encoding after reset release.

(5) N/A = Not applicable

(6) State after reset release: PU = High impedance with an active pullup resistor, OFF = High impedance, N/A = not applicable

表 4-2. Pin Attributes (continued)

PIN NUMBER	SIGNAL NAME <sup>(1)</sup>	SIGNAL TYPE <sup>(2)</sup>	BUFFER TYPE <sup>(3)</sup>	PIN MUX ENCODING <sup>(4)</sup>	POWER SOURCE <sup>(5)</sup>	STATE AFTER RESET RELEASE <sup>(6)</sup>
A11	PN2	I/O	LVC MOS	–	VDD	OFF
	EPI0S29	I/O	LVC MOS	PN2 (15)		N/A
	U1DCD	I	LVC MOS	PN2 (1)		N/A
	U2RTS	O	LVC MOS	PN2 (2)		N/A
A13	PQ4	I/O	LVC MOS	–	VDD	OFF
	DIVSCLK	O	LVC MOS	PQ4 (13)		N/A
	U1Rx	I	LVC MOS	PQ4 (1)		N/A
A14	PS3	I/O	LVC MOS	–	VDD	OFF
	LCDDATA23	O	LVC MOS	PS3 (15)		N/A
	M0FAULT3	I	LVC MOS	PS3 (6)		N/A
	T3CCP1	I/O	LVC MOS	PS3 (3)		N/A
A16	PB0	I/O	LVC MOS	–	VDD	OFF
	CAN1Rx	I	LVC MOS	PB0 (7)		N/A
	I2C5SCL	I/O	LVC MOS	PB0 (2)		N/A
	T4CCP0	I/O	LVC MOS	PB0 (3)		N/A
	U1Rx	I	LVC MOS	PB0 (1)		N/A
	USB0ID	I	Analog	PB0		N/A
A17	PB2	I/O	LVC MOS	–	VDD	OFF
	EN0MDC	O	LVC MOS	PB2 (5)		N/A
	EPI0S27	I/O	LVC MOS	PB2 (15)		N/A
	I2C0SCL	I/O	LVC MOS	PB2 (2)		N/A
	T5CCP0	I/O	LVC MOS	PB2 (3)		N/A
	USB0STP	O	LVC MOS	PB2 (14)		N/A
A18	GND	–	Power	Fixed	N/A	N/A
A19	GND	–	Power	Fixed	N/A	N/A
B1	GND	–	Power	Fixed	N/A	N/A
B2	PD7	I/O	LVC MOS	–	VDD	OFF
	AIN4	I	Analog	PD7		N/A
	NMI	I	LVC MOS	PD7 (8)		N/A
	SSI2XDAT2	I/O	LVC MOS	PD7 (15)		N/A
	T4CCP1	I/O	LVC MOS	PD7 (3)		N/A
	U2CTS	I	LVC MOS	PD7 (1)		N/A
	USB0PFLT	I	LVC MOS	PD7 (5)		N/A
B3	PD6	I/O	LVC MOS	–	VDD	OFF
	AIN5	I	Analog	PD6		N/A
	SSI2XDAT3	I/O	LVC MOS	PD6 (15)		N/A
	T4CCP0	I/O	LVC MOS	PD6 (3)		N/A
	U2RTS	O	LVC MOS	PD6 (1)		N/A
	USB0EPEN	O	LVC MOS	PD6 (5)		N/A
B4	PD5	I/O	LVC MOS	–	VDD	OFF
	AIN6	I	Analog	PD5		N/A
	SSI1XDAT3	I/O	LVC MOS	PD5 (15)		N/A
	T3CCP1	I/O	LVC MOS	PD5 (3)		N/A
	U2Tx	O	LVC MOS	PD5 (1)		N/A

**表 4-2. Pin Attributes (continued)**

PIN NUMBER	SIGNAL NAME <sup>(1)</sup>	SIGNAL TYPE <sup>(2)</sup>	BUFFER TYPE <sup>(3)</sup>	PIN MUX ENCODING <sup>(4)</sup>	POWER SOURCE <sup>(5)</sup>	STATE AFTER RESET RELEASE <sup>(6)</sup>
B5	PE5	I/O	LVC MOS	–	VDD	OFF
	AIN8	I	Analog	PE5		N/A
	SSI1XDAT1	I/O	LVC MOS	PE5 (15)		N/A
B6	PB5	I/O	LVC MOS	–	VDD	OFF
	AIN11	I	Analog	PB5		N/A
	I2C5SDA	I/O	LVC MOS	PB5 (2)		N/A
	SSI1Clk	I/O	LVC MOS	PB5 (15)		N/A
	U0RTS	O	LVC MOS	PB5 (1)		N/A
B7	PE7	I/O	LVC MOS	–	VDD	OFF
	AIN21	I	Analog	PE7		N/A
	I2C9SDA	I/O	LVC MOS	PE7 (2)		N/A
	NMI	I	LVC MOS	PE7 (8)		N/A
	U0RTS	O	LVC MOS	PE7 (1)		N/A
B8	PP6	I/O	LVC MOS	–	VDD	OFF
	AIN23	I	Analog	PP6		N/A
	I2C2SDA	I/O	LVC MOS	PP6 (2)		N/A
	U1DCD	I	LVC MOS	PP6 (1)		N/A
B9	PN5	I/O	LVC MOS	–	VDD	OFF
	EPI0S35	I/O	LVC MOS	PN5 (15)		N/A
	I2C2SCL	I/O	LVC MOS	PN5 (3)		N/A
	U1RI	I	LVC MOS	PN5 (1)		N/A
	U3CTS	I	LVC MOS	PN5 (2)		N/A
B10	PN3	I/O	LVC MOS	–	VDD	OFF
	EPI0S30	I/O	LVC MOS	PN3 (15)		N/A
	U1DSR	I	LVC MOS	PN3 (1)		N/A
	U2CTS	I	LVC MOS	PN3 (2)		N/A
B11	PN1	I/O	LVC MOS	–	VDD	OFF
	U1CTS	I	LVC MOS	PN1 (1)		N/A
B12	PP5	I/O	LVC MOS	–	VDD	OFF
	I2C2SCL	I/O	LVC MOS	PP5 (2)		N/A
	OWALT	I/O	LVC MOS	PP5 (4)		N/A
	U3CTS	I	LVC MOS	PP5 (1)		N/A
	USB0D6	I/O	LVC MOS	PP5 (14)		N/A
B13	PP2	I/O	LVC MOS	–	VDD	OFF
	EPI0S29	I/O	LVC MOS	PP2 (15)		N/A
	U0DTR	O	LVC MOS	PP2 (1)		N/A
	USB0NXT	O	LVC MOS	PP2 (14)		N/A
B14	PS2	I/O	LVC MOS	–	VDD	OFF
	LCDDATA22	O	LVC MOS	PS2 (15)		N/A
	M0FAULT2	I	LVC MOS	PS2 (6)		N/A
	T3CCP0	I/O	LVC MOS	PS2 (3)		N/A
	U1DSR	I	LVC MOS	PS2 (1)		N/A
B15	PC0	I/O	LVC MOS	–	VDD	N/A
	TCLK/SWCLK	I	LVC MOS	PC0 (1)		PU

表 4-2. Pin Attributes (continued)

PIN NUMBER	SIGNAL NAME <sup>(1)</sup>	SIGNAL TYPE <sup>(2)</sup>	BUFFER TYPE <sup>(3)</sup>	PIN MUX ENCODING <sup>(4)</sup>	POWER SOURCE <sup>(5)</sup>	STATE AFTER RESET RELEASE <sup>(6)</sup>
B16	PB1	I/O	LVC MOS	–	VDD	OFF
	CAN1Tx	O	LVC MOS	PB1 (7)		N/A
	I2C5SDA	I/O	LVC MOS	PB1 (2)		N/A
	T4CCP1	I/O	LVC MOS	PB1 (3)		N/A
	U1Tx	O	LVC MOS	PB1 (1)		N/A
	USB0VBUS	I/O	Analog	PB1		N/A
B17	PB3	I/O	LVC MOS	–	VDD	OFF
	EN0MDIO	I/O	LVC MOS	PB3 (5)		N/A
	EPI0S28	I/O	LVC MOS	PB3 (15)		N/A
	I2C0SDA	I/O	LVC MOS	PB3 (2)		N/A
	T5CCP1	I/O	LVC MOS	PB3 (3)		N/A
	USB0CLK	O	LVC MOS	PB3 (14)		N/A
B18	PL7	I/O	LVC MOS	–	VDD	OFF
	T1CCP1	I/O	LVC MOS	PL7 (3)		N/A
	USB0DM	I/O	Analog	PL7		N/A
B19	GND	–	Power	–	N/A	N/A
C1	PD1	I/O	LVC MOS	–	VDD	OFF
	AIN14	I	Analog	PD1		N/A
	C1o	O	LVC MOS	PD1 (5)		N/A
	I2C7SDA	I/O	LVC MOS	PD1 (2)		N/A
	SSI2XDAT0	I/O	LVC MOS	PD1 (15)		N/A
	T0CCP1	I/O	LVC MOS	PD1 (3)		N/A
C2	PD0	I/O	LVC MOS	–	VDD	OFF
	AIN15	I	Analog	PD0		N/A
	C0o	O	LVC MOS	PD0 (5)		N/A
	I2C7SCL	I/O	LVC MOS	PD0 (2)		N/A
	SSI2XDAT1	I/O	LVC MOS	PD0 (15)		N/A
	T0CCP0	I/O	LVC MOS	PD0 (3)		N/A
C5	NC	–	–	–	N/A	N/A
C6	PB4	I/O	LVC MOS	–	VDD	OFF
	AIN10	I	Analog	PB4		N/A
	I2C5SCL	I/O	LVC MOS	PB4 (2)		N/A
	SSI1Fss	I/O	LVC MOS	PB4 (15)		N/A
	U0CTS	I	LVC MOS	PB4 (1)		N/A
C8	PJ0	I/O	LVC MOS	–	VDD	OFF
	EN0PPS	O	LVC MOS	PJ0 (5)		N/A
	U3Rx	I	LVC MOS	PJ0 (1)		N/A
C10	PN0	I/O	LVC MOS	–	VDD	OFF
	U1RTS	O	LVC MOS	PN0 (1)		N/A
C12	PP3	I/O	LVC MOS	–	VDD	OFF
	EPI0S30	I/O	LVC MOS	PP3 (15)		N/A
	RTCCLK	O	LVC MOS	PP3 (7)		N/A
	U0DCD	I	LVC MOS	PP3 (2)		N/A
	U1CTS	I	LVC MOS	PP3 (1)		N/A
	USB0DIR	O	LVC MOS	PP3 (14)		N/A

表 4-2. Pin Attributes (continued)

PIN NUMBER	SIGNAL NAME <sup>(1)</sup>	SIGNAL TYPE <sup>(2)</sup>	BUFFER TYPE <sup>(3)</sup>	PIN MUX ENCODING <sup>(4)</sup>	POWER SOURCE <sup>(5)</sup>	STATE AFTER RESET RELEASE <sup>(6)</sup>
C14	PC3	I/O	LVC MOS	–	VDD	N/A
	TDO/SWO	O	LVC MOS	PC3 (1)		PU
C15	PC1	I/O	LVC MOS	–	VDD	N/A
	TMS/SWDIO	I/O	LVC MOS	PC1 (1)		PU
C18	PL6	I/O	LVC MOS	–	VDD	OFF
	T1CCP0	I/O	LVC MOS	PL6 (3)		N/A
	USB0DP	I/O	Analog	PL6		N/A
D1	PD3	I/O	LVC MOS	–	VDD	OFF
	AIN12	I	Analog	PD3		N/A
	I2C8SDA	I/O	LVC MOS	PD3 (2)		N/A
	SSI2CIk	I/O	LVC MOS	PD3 (15)		N/A
	T1CCP1	I/O	LVC MOS	PD3 (3)		N/A
D2	PD2	I/O	LVC MOS	–	VDD	OFF
	AIN13	I	Analog	PD2		N/A
	C2o	O	LVC MOS	PD2 (5)		N/A
	I2C8SCL	I/O	LVC MOS	PD0 (2)		N/A
	SSI2Fss	I/O	LVC MOS	PD2 (15)		N/A
	T1CCP0	I/O	LVC MOS	PD2 (3)		N/A
D6	PP0	I/O	LVC MOS	–	VDD	OFF
	C2+	I	Analog	PP0		N/A
	EN0INTRN	I	LVC MOS	PP0 (7)		N/A
	SSI3XDAT2	I/O	LVC MOS	PP0 (15)		N/A
	T6CCP0	I/O	LVC MOS	PP0 (5)		N/A
	U6Rx	I	LVC MOS	PP0 (1)		N/A
D7	PP1	I/O	LVC MOS	–	VDD	OFF
	C2-	I	Analog	PP1		N/A
	SSI3XDAT3	I/O	LVC MOS	PP1 (15)		N/A
	T6CCP1	I/O	LVC MOS	PP1 (5)		N/A
	U6Tx	O	LVC MOS	PP1 (1)		N/A
D8	PP4	I/O	LVC MOS	–	VDD	OFF
	OWIRE	I/O	LVC MOS	PP4 (4)		N/A
	U0DSR	I	LVC MOS	PP4 (2)		N/A
	U3RTS	O	LVC MOS	PP4 (1)		N/A
	USB0D7	I/O	LVC MOS	PP4 (14)		N/A
D12	PS0	I/O	LVC MOS	–	VDD	OFF
	LCDDATA20	O	LVC MOS	PS0 (15)		N/A
	M0FAULT0	I	LVC MOS	PS0 (6)		N/A
	T2CCP0	I/O	LVC MOS	PS0 (3)		N/A
D13	PS1	I/O	LVC MOS	–	VDD	OFF
	LCDDATA21	O	LVC MOS	PS1 (15)		N/A
	M0FAULT1	I	LVC MOS	PS1 (6)		N/A
	T2CCP1	I/O	LVC MOS	PS1 (3)		N/A
D14	PC2	I/O	LVC MOS	–	VDD	N/A
	TDI	I	LVC MOS	PC2 (1)		PU
D18	GNDX2	–	Power	Fixed	N/A	N/A
D19	OSC1	O	Analog	Fixed	VDD	N/A

表 4-2. Pin Attributes (continued)

PIN NUMBER	SIGNAL NAME <sup>(1)</sup>	SIGNAL TYPE <sup>(2)</sup>	BUFFER TYPE <sup>(3)</sup>	PIN MUX ENCODING <sup>(4)</sup>	POWER SOURCE <sup>(5)</sup>	STATE AFTER RESET RELEASE <sup>(6)</sup>
E2	PQ1	I/O	LVC MOS	–	VDD	OFF
	EPI0S21	I/O	LVC MOS	PQ1 (15)		N/A
	SSI3Fss	I/O	LVC MOS	PQ1 (14)		N/A
	T6CCP1	I/O	LVC MOS	PQ1 (3)		N/A
E3	PQ0	I/O	LVC MOS	–	VDD	OFF
	EPI0S20	I/O	LVC MOS	PQ0 (15)		N/A
	SSI3Clk	I/O	LVC MOS	PQ0 (14)		N/A
	T6CCP0	I/O	LVC MOS	PQ0 (3)		N/A
E7	PJ1	I/O	LVC MOS	–	VDD	OFF
	U3Tx	O	LVC MOS	PJ1 (1)		N/A
E10	VDDC	–	Power	Fixed	N/A	N/A
E13	NC	–	–	–	N/A	N/A
E17	PJ5	I/O	LVC MOS	–	VDD	OFF
	LCDDATA17	O	LVC MOS	PJ5 (15)		N/A
	U3CTS	I	LVC MOS	PJ5 (1)		N/A
E18	PT2	I/O	LVC MOS	–	VDD	OFF
	CAN1Rx	I	LVC MOS	PT2 (7)		N/A
	LCDDATA18	O	LVC MOS	PT2 (15)		N/A
	T7CCP0	I/O	LVC MOS	PT2 (3)		N/A
E19	OSC0	I	Analog	Fixed	VDD	N/A
F1	PB7	I/O	LVC MOS	–	VDD	OFF
	I2C6SDA	I/O	LVC MOS	PB7 (1)		N/A
	T6CCP1	I/O	LVC MOS	PB7 (3)		N/A
F2	PB6	I/O	LVC MOS	–	VDD	OFF
	I2C6SCL	I/O	LVC MOS	PB6 (1)		N/A
	T6CCP0	I/O	LVC MOS	PB6 (3)		N/A
F3	VDDA	–	Power	Fixed	N/A	N/A
F4	VREFA+	–	Analog	Fixed	VDD	N/A
F10	GND	–	Power	Fixed	N/A	N/A
F16	PJ3	I/O	LVC MOS	–	VDD	OFF
	LCDDATA15	I/O	LVC MOS	PJ3 (15)		N/A
	U2CTS	I	LVC MOS	PJ3 (1)		N/A
F17	PT3	I/O	LVC MOS	–	VDD	OFF
	CAN1Tx	O	LVC MOS	PT3 (7)		N/A
	LCDDATA19	O	LVC MOS	PT3 (15)		N/A
	T7CCP1	I/O	LVC MOS	PT3 (3)		N/A
F18	PJ4	I/O	LVC MOS	–	VDD	OFF
	LCDDATA16	O	LVC MOS	PJ4 (15)		N/A
	U3RTS	O	LVC MOS	PJ4 (1)		N/A
G1	PE2	I/O	LVC MOS	–	VDD	OFF
	AIN1	I	Analog	PE3		N/A
	U1DCD	I	LVC MOS	PE1 (1)		N/A
G2	PE3	I/O	LVC MOS	–	VDD	OFF
	AIN0	I	Analog	PE3		N/A
	OWIRE	I/O	LVC MOS	PE3 (5)		N/A
	U1DTR	O	LVC MOS	PE3 (1)		N/A

表 4-2. Pin Attributes (continued)

PIN NUMBER	SIGNAL NAME <sup>(1)</sup>	SIGNAL TYPE <sup>(2)</sup>	BUFFER TYPE <sup>(3)</sup>	PIN MUX ENCODING <sup>(4)</sup>	POWER SOURCE <sup>(5)</sup>	STATE AFTER RESET RELEASE <sup>(6)</sup>
G4	GNDA	–	Power	Fixed	N/A	N/A
G5	VREFA-	–	Analog	Fixed	VDD	N/A
G10	VDD	–	Power	Fixed	N/A	N/A
G15	PM5	I/O	LVC MOS	–	VDD	OFF
	T4CCP1	I/O	LVC MOS	PM5 (3)		N/A
	TMPR2	I/O	LVC MOS	PM5		N/A
	U0DCD	I	LVC MOS	PM5 (1)		N/A
G16	PL0	I/O	LVC MOS	–	VDD	OFF
	EPI0S16	I/O	LVC MOS	PL0 (15)		N/A
	I2C2SDA	I/O	LVC MOS	PL0 (2)		N/A
	M0FAULT3	I	LVC MOS	PL0 (6)		N/A
	USB0D0	I/O	LVC MOS	PL0 (14)		N/A
G18	PL2	I/O	LVC MOS	–	VDD	OFF
	C0o	O	LVC MOS	PL2 (5)		N/A
	EPI0S18	I/O	LVC MOS	PL2 (15)		N/A
	PhB0	I	LVC MOS	PL2 (6)		N/A
	USB0D2	I/O	LVC MOS	PL2 (14)		N/A
G19	PL5	I/O	LVC MOS	–	VDD	OFF
	EPI0S33	I/O	LVC MOS	PL5 (15)		N/A
	T0CCP1	I/O	LVC MOS	PL5 (3)		N/A
	USB0D5	I/O	LVC MOS	PL5 (14)		N/A
H2	PE1	I/O	LVC MOS	–	VDD	OFF
	AIN2	I	Analog	PE1		N/A
	U1DSR	I	LVC MOS	PE1 (1)		N/A
H3	PE0	I/O	LVC MOS	–	VDD	OFF
	AIN3	I	Analog	PE0		N/A
	U1RTS	O	LVC MOS	PE0 (1)		N/A
H4	PQ2	I/O	LVC MOS	–	VDD	OFF
	EPI0S22	I/O	LVC MOS	PQ2 (15)		N/A
	SSI3XDAT0	I/O	LVC MOS	PQ2 (14)		N/A
	T7CCP0	I/O	LVC MOS	PQ2 (3)		N/A
H9	VDD	–	Power	Fixed	N/A	N/A
H10	GND	–	Power	Fixed	N/A	N/A
H11	GND	–	Power	Fixed	N/A	N/A
H12	GND	–	Power	Fixed	N/A	N/A
H16	VDDC	–	Power	Fixed	N/A	N/A
H17	PJ2	I/O	LVC MOS	–	VDD	OFF
	LCDDATA14	I/O	LVC MOS	PJ2 (15)		N/A
	U2RTS	O	LVC MOS	PJ2 (1)		N/A
H18	PL4	I/O	LVC MOS	–	VDD	OFF
	EPI0S26	I/O	LVC MOS	PL4 (15)		N/A
	T0CCP0	I/O	LVC MOS	PL4 (3)		N/A
	USB0D4	I/O	LVC MOS	PL4 (14)		N/A

表 4-2. Pin Attributes (continued)

PIN NUMBER	SIGNAL NAME <sup>(1)</sup>	SIGNAL TYPE <sup>(2)</sup>	BUFFER TYPE <sup>(3)</sup>	PIN MUX ENCODING <sup>(4)</sup>	POWER SOURCE <sup>(5)</sup>	STATE AFTER RESET RELEASE <sup>(6)</sup>
H19	PL1	I/O	LVC MOS	–	VDD	OFF
	EPI0S17	I/O	LVC MOS	PL1 (15)		N/A
	I2C2SCL	I/O	LVC MOS	PL1 (2)		N/A
	PhA0	I	LVC MOS	PL1 (6)		N/A
	USB0D1	I/O	LVC MOS	PL1 (14)		N/A
J1	PK0	I/O	LVC MOS	–	VDD	OFF
	AIN16	I	Analog	PK0		N/A
	EPI0S0	I/O	LVC MOS	PK0 (15)		N/A
	U4Rx	I	LVC MOS	PK0 (1)		N/A
J2	PK1	I/O	LVC MOS	–	VDD	OFF
	AIN17	I	Analog	PK1		N/A
	EPI0S1	I/O	LVC MOS	PK1 (15)		N/A
	U4Tx	O	LVC MOS	PK1 (1)		N/A
J8	VDD	–	Power	Fixed	N/A	N/A
J9	VDD	–	Power	Fixed	N/A	N/A
J10	VDD	–	Power	Fixed	N/A	N/A
J11	GND	–	Power	Fixed	N/A	N/A
J12	GND	–	Power	Fixed	N/A	N/A
J18	PL3	I/O	LVC MOS	–	VDD	OFF
	C1o	O	LVC MOS	PL3 (5)		N/A
	EPI0S19	I/O	LVC MOS	PL3 (15)		N/A
	IDX0	I	LVC MOS	PL3 (6)		N/A
	USB0D3	I/O	LVC MOS	PL3 (14)		N/A
K1	PK2	I/O	LVC MOS	–	VDD	OFF
	AIN18	I	Analog	PK2		N/A
	EPI0S2	I/O	LVC MOS	PK2 (15)		N/A
	U4RTS	O	LVC MOS	PK2 (1)		N/A
K2	PK3	I/O	LVC MOS	–	VDD	OFF
	AIN19	I	Analog	PK3		N/A
	EPI0S3	I/O	LVC MOS	PK3 (15)		N/A
	U4CTS	I	LVC MOS	PK3 (1)		N/A
K3	PC7	I/O	LVC MOS	–	VDD	OFF
	C0-	I	Analog	PC7		N/A
	EPI0S4	I/O	LVC MOS	PC7 (15)		N/A
	U5Tx	O	LVC MOS	PC7 (1)		N/A
K5	PJ7	I/O	LVC MOS	–	VDD	OFF
	U4CTS	I	LVC MOS	PK3 (1)		N/A
K6	GND	–	Power	Fixed	N/A	N/A
K7	VDD	–	Power	Fixed	N/A	N/A
K8	VDD	–	Power	Fixed	N/A	N/A
K9	GND	–	Power	Fixed	N/A	N/A
K10	GND	–	Power	Fixed	N/A	N/A
K11	VDD	–	Power	Fixed	N/A	N/A
K12	VDD	–	Power	Fixed	N/A	N/A
K13	GND	–	Power	Fixed	N/A	N/A
K14	GND	–	Power	Fixed	N/A	N/A



**表 4-2. Pin Attributes (continued)**

PIN NUMBER	SIGNAL NAME <sup>(1)</sup>	SIGNAL TYPE <sup>(2)</sup>	BUFFER TYPE <sup>(3)</sup>	PIN MUX ENCODING <sup>(4)</sup>	POWER SOURCE <sup>(5)</sup>	STATE AFTER RESET RELEASE <sup>(6)</sup>
K15	PG5	I/O	LVC MOS	–	VDD	OFF
	EN0TXD1	O	LVC MOS	PG5 (14)		N/A
	I2C3SDA	I/O	LVC MOS	PG5 (2)		N/A
	OWALT	I/O	LVC MOS	PG5 (5)		N/A
	SSI2XDAT0	I/O	LVC MOS	PG5 (15)		N/A
	U0RTS	O	LVC MOS	PG5 (1)		N/A
K17	PG4	I/O	LVC MOS	–	VDD	OFF
	EN0TXD0	O	LVC MOS	PG4 (14)		N/A
	I2C3SCL	I/O	LVC MOS	PG4 (2)		N/A
	OWIRE	I/O	LVC MOS	PG4 (5)		N/A
	SSI2XDAT1	I/O	LVC MOS	PG4 (15)		N/A
	U0CTS	I	LVC MOS	PG4 (1)		N/A
K18	PM0	I/O	LVC MOS	–	VDD	OFF
	EPI0S15	I/O	LVC MOS	PM0 (15)		N/A
	T2CCP0	I/O	LVC MOS	PM0 (3)		N/A
K19	PM1	I/O	LVC MOS	–	VDD	OFF
	EPI0S14	I/O	LVC MOS	PM1 (15)		N/A
	T2CCP1	I/O	LVC MOS	PM1 (3)		N/A
L2	PC6	I/O	LVC MOS	–	VDD	OFF
	C0+	I	Analog	PC6		N/A
	EPI0S5	I/O	LVC MOS	PC6 (15)		N/A
	U5Rx	I	LVC MOS	PC6 (1)		N/A
L8	GND	–	Power	Fixed	N/A	N/A
L9	GND	–	Power	Fixed	N/A	N/A
L10	VDD	–	Power	Fixed	N/A	N/A
L11	VDD	–	Power	Fixed	N/A	N/A
L12	VDD	–	Power	Fixed	N/A	N/A
L18	PM2	I/O	LVC MOS	–	VDD	OFF
	EPI0S13	I/O	LVC MOS	PM2 (15)		N/A
	T3CCP0	I/O	LVC MOS	PM2 (3)		N/A
L19	PM3	I/O	LVC MOS	–	VDD	OFF
	EPI0S12	I/O	LVC MOS	PM3 (15)		N/A
	T3CCP1	I/O	LVC MOS	PM3 (3)		N/A
M1	PC5	I/O	LVC MOS	–	VDD	OFF
	C1+	I	Analog	PC5		N/A
	EPI0S6	I/O	LVC MOS	PC5 (15)		N/A
	RTCCLK	O	LVC MOS	PC5 (7)		N/A
	T7CCP1	I/O	LVC MOS	PC5 (3)		N/A
	U7Tx	O	LVC MOS	PC5 (1)		N/A
M2	PC4	I/O	LVC MOS	–	VDD	OFF
	C1-	I	Analog	PC4		N/A
	EPI0S7	I/O	LVC MOS	PC4 (15)		N/A
	T7CCP0	I/O	LVC MOS	PC4 (3)		N/A
	U7Rx	I	LVC MOS	PC4 (1)		N/A
M3	PQ7	I/O	LVC MOS	–	VDD	OFF
	U1RI	I	LVC MOS	PQ7 (1)		N/A

表 4-2. Pin Attributes (continued)

PIN NUMBER	SIGNAL NAME <sup>(1)</sup>	SIGNAL TYPE <sup>(2)</sup>	BUFFER TYPE <sup>(3)</sup>	PIN MUX ENCODING <sup>(4)</sup>	POWER SOURCE <sup>(5)</sup>	STATE AFTER RESET RELEASE <sup>(6)</sup>
M4	PQ3	I/O	LVC MOS	–	VDD	OFF
	EPI0S23	I/O	LVC MOS	PQ3 (15)		N/A
	SSI3XDAT1	I/O	LVC MOS	PQ3 (14)		N/A
	T7CCP1	I/O	LVC MOS	PQ3 (3)		N/A
M8	GND	–	Power	Fixed	N/A	N/A
M9	GND	–	Power	Fixed	N/A	N/A
M10	GND	–	Power	Fixed	N/A	N/A
M11	VDD	–	Power	Fixed	N/A	N/A
M12	VDD	–	Power	Fixed	N/A	N/A
M16	PG3	I/O	LVC MOS	–	VDD	OFF
	EN0TXEN	O	LVC MOS	PG3 (14)		N/A
	I2C2SDA	I/O	LVC MOS	PG3 (2)		N/A
	SSI2XDAT2	I/O	LVC MOS	PG3 (15)		N/A
M17	HIB	O	LVC MOS	Fixed	VBAT	OFF
M18	PM4	I/O	LVC MOS	–	VDD	OFF
	EN0REF_CLK	I/O	LVC MOS	PM4 (14)		N/A
	T4CCP0	I/O	LVC MOS	PM4 (3)		N/A
	TMPR3	I/O	LVC MOS	PM4		N/A
	U0CTS	I	LVC MOS	PM4 (1)		N/A
N1	PJ6	I/O	LVC MOS	–	VDD	OFF
	LCDAC	O	LVC MOS	PJ6 (15)		N/A
	U4RTS	O	LVC MOS	PJ6 (1)		N/A
N2	PR2	I/O	LVC MOS	–	VDD	OFF
	I2C2SCL	I/O	LVC MOS	PR2 (2)		N/A
	LCDLP	O	LVC MOS	PR2 (15)		N/A
	M0PWM2	O	LVC MOS	PR2 (6)		N/A
N4	PR1	I/O	LVC MOS	–	VDD	OFF
	I2C1SDA	I/O	LVC MOS	PR1 (2)		N/A
	LCDFP	O	LVC MOS	PR1 (15)		N/A
	M0PWM1	O	LVC MOS	PR1 (6)		N/A
	U4Rx	I	LVC MOS	PR1 (1)		N/A
N5	PR0	I/O	LVC MOS	–	VDD	OFF
	I2C1SCL	I/O	LVC MOS	PR0 (2)		N/A
	LCDCP	O	LVC MOS	PR0 (15)		N/A
	M0PWM0	O	LVC MOS	PR0 (6)		N/A
	U4Tx	O	LVC MOS	PR0 (1)		N/A
N10	GND	–	Power	Fixed	N/A	N/A
N15	PG0	I/O	LVC MOS	–	VDD	OFF
	EN0PPS	O	LVC MOS	PG0 (5)		N/A
	EPI0S11	I/O	LVC MOS	PG0 (15)		N/A
	I2C1SCL	I/O	LVC MOS	PG0 (2)		N/A
	M0PWM4	O	LVC MOS	PG0 (6)		N/A
N16	VDD	–	Power	Fixed	N/A	N/A

表 4-2. Pin Attributes (continued)

PIN NUMBER	SIGNAL NAME <sup>(1)</sup>	SIGNAL TYPE <sup>(2)</sup>	BUFFER TYPE <sup>(3)</sup>	PIN MUX ENCODING <sup>(4)</sup>	POWER SOURCE <sup>(5)</sup>	STATE AFTER RESET RELEASE <sup>(6)</sup>
N18	PM7	I/O	LVC MOS	–	VDD	OFF
	EN0COL	I	LVC MOS	PM6 (14)		N/A
	T5CCP1	I/O	LVC MOS	PM7 (3)		N/A
	TMPR0	I/O	LVC MOS	PM7		N/A
	U0RI	I	LVC MOS	PM7 (1)		N/A
N19	PM6	I/O	LVC MOS	–	VDD	OFF
	EN0CRS	I	LVC MOS	PM6 (14)		N/A
	T5CCP0	I/O	LVC MOS	PM6 (3)		N/A
	TMPR1	I/O	LVC MOS	PM6		N/A
	U0DSR	I	LVC MOS	PM6 (1)		N/A
P2	PR5	I/O	LVC MOS	–	VDD	OFF
	I2C3SDA	I/O	LVC MOS	PR5 (2)		N/A
	LCDDATA01	I/O	LVC MOS	PR5 (15)		N/A
	M0PWM5	O	LVC MOS	PR5 (6)		N/A
	T0CCP1	I/O	LVC MOS	PR5 (3)		N/A
	U1Rx	I	LVC MOS	PR5 (1)		N/A
P3	PR4	I/O	LVC MOS	–	VDD	OFF
	I2C3SCL	I/O	LVC MOS	PR4 (2)		N/A
	LCDDATA00	I/O	LVC MOS	PR4 (15)		N/A
	M0PWM4	O	LVC MOS	PR4 (6)		N/A
	T0CCP0	I/O	LVC MOS	PR4 (3)		N/A
P4	PH0	I/O	LVC MOS	–	VDD	OFF
	EPI0S0	I/O	LVC MOS	PH0 (15)		N/A
	U0RTS	O	LVC MOS	PH0 (1)		N/A
P10	VDD	–	Power	Fixed	N/A	N/A
P16	GND	–	Power	Fixed	N/A	N/A
P17	VDD	–	Power	Fixed	N/A	N/A
P18	RST	I	LVC MOS	Fixed	VDD	OFF
P19	VBAT	–	Power	Fixed	N/A	N/A
R1	PH2	I/O	LVC MOS	–	VDD	OFF
	EPI0S2	I/O	LVC MOS	PH2 (15)		N/A
	U0DCD	I	LVC MOS	PH2 (1)		N/A
R2	PH1	I/O	LVC MOS	–	VDD	OFF
	EPI0S1	I/O	LVC MOS	PH1 (15)		N/A
	U0CTS	I	LVC MOS	PH1 (1)		N/A
R3	PH4	I/O	LVC MOS	–	VDD	OFF
	U0DTR	O	LVC MOS	PH4 (1)		N/A
R7	PA7	I/O	LVC MOS	–	VDD	OFF
	EPI0S9	I/O	LVC MOS	PA7 (15)		N/A
	I2C6SDA	I/O	LVC MOS	PA7 (2)		N/A
	SSI0XDAT3	I/O	LVC MOS	PA7 (13)		N/A
	T3CCP1	I/O	LVC MOS	PA7 (3)		N/A
	U2Tx	O	LVC MOS	PA7 (1)		N/A
	USB0EPEN	O	LVC MOS	PA7 (11)		N/A
	USB0PFLT	I	LVC MOS	PA7 (5)		N/A

表 4-2. Pin Attributes (continued)

PIN NUMBER	SIGNAL NAME <sup>(1)</sup>	SIGNAL TYPE <sup>(2)</sup>	BUFFER TYPE <sup>(3)</sup>	PIN MUX ENCODING <sup>(4)</sup>	POWER SOURCE <sup>(5)</sup>	STATE AFTER RESET RELEASE <sup>(6)</sup>
R10	PR7	I/O	LVC MOS	–	VDD	OFF
	EN0TXEN	O	LVC MOS	PR7 (14)		N/A
	I2C4SDA	I/O	LVC MOS	PR7 (2)		N/A
	LCDDATA05	I/O	LVC MOS	PR7 (15)		N/A
	M0PWM7	O	LVC MOS	PR7 (6)		N/A
	T1CCP1	I/O	LVC MOS	PR7 (3)		N/A
R13	PS7	I/O	LVC MOS	–	VDD	OFF
	EN0RXDV	I	LVC MOS	PS7 (14)		N/A
	LCDDATA09	I/O	LVC MOS	PS7 (15)		N/A
	T5CCP1	I/O	LVC MOS	PS7 (3)		N/A
R17	GND	–	Power	Fixed	N/A	N/A
R18	GNDX	–	Power	Fixed	N/A	N/A
T1	PH3	I/O	LVC MOS	–	VDD	OFF
	EPI0S3	I/O	LVC MOS	PH3 (15)		N/A
	U0DSR	I	LVC MOS	PH3 (1)		N/A
T2	PH5	I/O	LVC MOS	–	VDD	OFF
	EN0PPS	O	LVC MOS	PH5 (15)		N/A
	U0RI	I	LVC MOS	PH5 (1)		N/A
T6	PA2	I/O	LVC MOS	–	VDD	OFF
	I2C8SCL	I/O	LVC MOS	PA2 (2)		N/A
	SSI0CIk	I/O	LVC MOS	PA2 (15)		N/A
	T1CCP0	I/O	LVC MOS	PA2 (3)		N/A
	U4Rx	I	LVC MOS	PA2 (1)		N/A
T7	PF3	I/O	LVC MOS	–	VDD	OFF
	EN0MDIO	I/O	LVC MOS	PF3 (5)		N/A
	M0PWM3	O	LVC MOS	PF3 (6)		N/A
	SSI3CIk	I/O	LVC MOS	PF3 (14)		N/A
	TRCLK	O	LVC MOS	PF3 (15)		N/A
T8	PF6	I/O	LVC MOS	–	VDD	OFF
	LCDMCLK	O	LVC MOS	PF6 (15)		N/A
T12	PN6	I/O	LVC MOS	–	VDD	OFF
	EN0TXER	O	LVC MOS	PN6 (14)		N/A
	LCDDATA13	I/O	LVC MOS	PN6 (15)		N/A
	U4RTS	O	LVC MOS	PN6 (2)		N/A
T13	PS5	I/O	LVC MOS	–	VDD	OFF
	EN0TXD1	O	LVC MOS	PS5 (14)		N/A
	LCDDATA07	I/O	LVC MOS	PS5 (15)		N/A
	PhB0	I	LVC MOS	PS5 (6)		N/A
	T4CCP1	I/O	LVC MOS	PS5 (3)		N/A
G14	PG1	I/O	LVC MOS	–	VDD	OFF
	EPI0S10	I/O	LVC MOS	PG1 (15)		N/A
	I2C1SDA	I/O	LVC MOS	PG1 (2)		N/A
	M0PWM5	O	LVC MOS	PG1 (6)		N/A
T18	XOSC0	I	Analog	Fixed	VBAT	N/A
T19	XOSC1	O	Analog	Fixed	VBAT	N/A

**表 4-2. Pin Attributes (continued)**

PIN NUMBER	SIGNAL NAME <sup>(1)</sup>	SIGNAL TYPE <sup>(2)</sup>	BUFFER TYPE <sup>(3)</sup>	PIN MUX ENCODING <sup>(4)</sup>	POWER SOURCE <sup>(5)</sup>	STATE AFTER RESET RELEASE <sup>(6)</sup>
U2	PH6	I/O	LVC MOS	–	VDD	OFF
	U5Rx	I	LVC MOS	PH6 (1)		N/A
	U7Rx	I	LVC MOS	PH6 (2)		N/A
U5	PA3	I/O	LVC MOS	–	VDD	OFF
	I2C8SDA	I/O	LVC MOS	PA3 (2)		N/A
	SSI0Fss	I/O	LVC MOS	PA3 (15)		N/A
	T1CCP1	I/O	LVC MOS	PA3 (2)		N/A
	U4Tx	O	LVC MOS	PA3 (1)		N/A
U6	PF0	I/O	LVC MOS	–	VDD	OFF
	EN0LED0	O	LVC MOS	PF0 (5)		N/A
	M0PWM0	O	LVC MOS	PF0 (6)		N/A
	SSI3XDAT1	I/O	LVC MOS	PF0 (14)		N/A
	TRD2	O	LVC MOS	PF0 (15)		N/A
U8	PF7	I/O	LVC MOS	–	VDD	OFF
	LCDDATA02	I/O	LVC MOS	PF7 (15)		N/A
U10	PS6	I/O	LVC MOS	–	VDD	OFF
	EN0RXER	I	LVC MOS	PS6 (14)		N/A
	IDX0	I	LVC MOS	PS6 (6)		N/A
	LCDDATA08	I/O	LVC MOS	PS6 (15)		N/A
	T5CCP0	I/O	LVC MOS	PS6 (3)		N/A
U12	PN7	I/O	LVC MOS	–	VDD	OFF
	LCDDATA12	I/O	LVC MOS	PN7 (15)		N/A
	U1RTS	O	LVC MOS	PN7 (1)		N/A
	U4CTS	I	LVC MOS	PN7 (2)		N/A
U14	PG7	I/O	LVC MOS	–	VDD	OFF
	EN0RXDV	I	LVC MOS	PG7 (14)		N/A
	I2C4SDA	I/O	LVC MOS	PG7 (2)		N/A
	OWIRE	I/O	LVC MOS	PG7 (5)		N/A
	SSI2Ck	I/O	LVC MOS	PG7 (15)		N/A
U15	PQ6	I/O	LVC MOS	–	VDD	OFF
	EN0RXD1	I	LVC MOS	PQ6 (14)		N/A
	U1DTR	O	LVC MOS	PQ6 (1)		N/A
U18	WAKE	I	LVC MOS	Fixed	VBAT	OFF
U19	PK4	I/O	LVC MOS	–	VDD	OFF
	EN0INTRN	I	LVC MOS	PK4 (7)		N/A
	EN0LED0	O	LVC MOS	PK4 (5)		N/A
	EN0RXD3	I	LVC MOS	PK4 (14)		N/A
	EPI0S32	I/O	LVC MOS	PK4 (15)		N/A
	I2C3SCL	I/O	LVC MOS	PK4 (2)		N/A
	M0PWM6	O	LVC MOS	PR6 (6)		N/A
V1	GND	–	Power	Fixed	N/A	N/A
V2	PH7	I/O	LVC MOS	–	VDD	OFF
	U5Tx	O	LVC MOS	PH7 (1)		N/A
	U7Tx	O	LVC MOS	PH7 (2)		N/A

表 4-2. Pin Attributes (continued)

PIN NUMBER	SIGNAL NAME <sup>(1)</sup>	SIGNAL TYPE <sup>(2)</sup>	BUFFER TYPE <sup>(3)</sup>	PIN MUX ENCODING <sup>(4)</sup>	POWER SOURCE <sup>(5)</sup>	STATE AFTER RESET RELEASE <sup>(6)</sup>
V3	PA0	I/O	LVC MOS	–	VDD	OFF
	CAN0Rx	I	LVC MOS	PA0 (7)		N/A
	I2C9SCL	I/O	LVC MOS	PA0 (2)		N/A
	TOCCP0	I/O	LVC MOS	PA0 (3)		N/A
	U0Rx	I	LVC MOS	PA0 (1)		N/A
V4	PA4	I/O	LVC MOS	–	VDD	OFF
	I2C7SCL	I/O	LVC MOS	PA4 (2)		N/A
	SSI0XDAT0	I/O	LVC MOS	PA4 (15)		N/A
	T2CCP0	I/O	LVC MOS	PA4 (3)		N/A
	U3Rx	I	LVC MOS	PA4 (1)		N/A
V5	PA6	I/O	LVC MOS	–	VDD	OFF
	EN0RXCK	I	LVC MOS	PA6 (14)		N/A
	EPI0S8	I/O	LVC MOS	PA6 (15)		N/A
	I2C6SCL	I/O	LVC MOS	PA6 (2)		N/A
	SSI0XDAT2	I/O	LVC MOS	PA6 (13)		N/A
	T3CCP0	I/O	LVC MOS	PA6 (3)		N/A
	U2Rx	I	LVC MOS	PA6 (1)		N/A
	USB0EPEN	O	LVC MOS	PA6 (5)		N/A
V6	PF1	I/O	LVC MOS	–	VDD	OFF
	EN0LED2	O	LVC MOS	PF1 (5)		N/A
	M0PWM1	O	LVC MOS	PF1 (6)		N/A
	SSI3XDAT0	I/O	LVC MOS	PF1 (14)		N/A
	TRD1	O	LVC MOS	PF1 (15)		N/A
V7	PF4	I/O	LVC MOS	–	VDD	OFF
	EN0LED1	O	LVC MOS	PF4 (5)		N/A
	M0FAULT0	I	LVC MOS	PF4 (6)		N/A
	SSI3XDAT2	I/O	LVC MOS	PF4 (14)		N/A
	TRD3	O	LVC MOS	PF4 (15)		N/A
V8	PR3	I/O	LVC MOS	–	VDD	OFF
	I2C2SDA	I/O	LVC MOS	PR3 (2)		N/A
	LCDDATA03	I/O	LVC MOS	PR3 (15)		N/A
	M0PWM3	O	LVC MOS	PR3 (6)		N/A
V9	PS4	I/O	LVC MOS	–	VDD	OFF
	EN0TXD0	O	LVC MOS	PS4 (14)		N/A
	LCDDATA06	I/O	LVC MOS	PS4 (15)		N/A
	PhA0	I	LVC MOS	PS4 (6)		N/A
	T4CCP0	I/O	LVC MOS	PS4 (3)		N/A
V10	PT1	I/O	LVC MOS	–	VDD	OFF
	CAN0Tx	O	LVC MOS	PT1 (7)		N/A
	EN0RXD1	I	LVC MOS	PT1 (14)		N/A
	LCDDATA11	I/O	LVC MOS	PT1 (15)		N/A
	T6CCP1	I/O	LVC MOS	PT1 (3)		N/A
V11	PG2	I/O	LVC MOS	–	VDD	OFF
	EN0TXCK	I	LVC MOS	PG2 (14)		N/A
	I2C2SCL	I/O	LVC MOS	PG2 (2)		N/A
	SSI2XDAT3	I/O	LVC MOS	PG2 (15)		N/A

**表 4-2. Pin Attributes (continued)**

PIN NUMBER	SIGNAL NAME <sup>(1)</sup>	SIGNAL TYPE <sup>(2)</sup>	BUFFER TYPE <sup>(3)</sup>	PIN MUX ENCODING <sup>(4)</sup>	POWER SOURCE <sup>(5)</sup>	STATE AFTER RESET RELEASE <sup>(6)</sup>
V12	PG6	I/O	LVC MOS	–	VDD	OFF
	EN0RXER	I	LVC MOS	PG6 (14)		N/A
	I2C4SCL	I/O	LVC MOS	PG6 (2)		N/A
	OWIRE	I/O	LVC MOS	PG6 (5)		N/A
	SSI2Fss	I/O	LVC MOS	PG6 (15)		N/A
V13	EN0RXIN	I/O	LVC MOS	Fixed	VDD	OFF
V14	EN0TXON	I/O	LVC MOS	Fixed	VDD	OFF
V15	EN0TXOP	I/O	LVC MOS	Fixed	VDD	OFF
V16	PK6	I/O	LVC MOS	–	VDD	OFF
	EN0LED1	O	LVC MOS	PK6 (5)		N/A
	EN0TXD2	O	LVC MOS	PK6 (14)		N/A
	EPI0S25	I/O	LVC MOS	PK6 (15)		N/A
	I2C4SCL	I/O	LVC MOS	PK6 (2)		N/A
	M0FAULT1	I	LVC MOS	PK6 (6)		N/A
V17	PK5	I/O	LVC MOS	–	VDD	OFF
	EN0LED2	O	LVC MOS	PK5 (5)		N/A
	EN0RXD2	I	LVC MOS	PK5 (14)		N/A
	EPI0S31	I/O	LVC MOS	PK5 (15)		N/A
	I2C3SDA	I/O	LVC MOS	PK5 (2)		N/A
	M0PWM7	O	LVC MOS	PK5 (6)		N/A
V18	NC	–	–	–	N/A	N/A
V19	NC	–	–	–	N/A	N/A
W1	GND	–	Power	Fixed	N/A	N/A
W2	GND	–	Power	Fixed	N/A	N/A
W3	PA1	I/O	LVC MOS	–	VDD	OFF
	CAN0Tx	O	LVC MOS	PA1 (7)		N/A
	I2C9SDA	I/O	LVC MOS	PA1 (2)		N/A
	TOCCP1	I/O	LVC MOS	PA1 (3)		N/A
	U0Tx	O	LVC MOS	PA1 (1)		N/A
W4	PA5	I/O	LVC MOS	–	VDD	OFF
	I2C7SDA	I/O	LVC MOS	PA5 (2)		N/A
	SSI0XDAT1	I/O	LVC MOS	PA5 (15)		N/A
	T2CCP1	I/O	LVC MOS	PA5 (3)		N/A
	U3Tx	O	LVC MOS	PA5 (1)		N/A
W6	PF2	I/O	LVC MOS	–	VDD	OFF
	EN0MDC	O	LVC MOS	PF2 (5)		N/A
	M0PWM2	O	LVC MOS	PF2 (6)		N/A
	SSI3Fss	I/O	LVC MOS	PF2 (14)		N/A
	TRD0	O	LVC MOS	PF2 (15)		N/A
W7	PF5	I/O	LVC MOS	–	VDD	OFF
	SSI3XDAT3	I/O	LVC MOS	PF5 (14)		N/A

表 4-2. Pin Attributes (continued)

PIN NUMBER	SIGNAL NAME <sup>(1)</sup>	SIGNAL TYPE <sup>(2)</sup>	BUFFER TYPE <sup>(3)</sup>	PIN MUX ENCODING <sup>(4)</sup>	POWER SOURCE <sup>(5)</sup>	STATE AFTER RESET RELEASE <sup>(6)</sup>
W9	PR6	I/O	LVC MOS	–	VDD	OFF
	I2C4SCL	I/O	LVC MOS	PR6 (2)		N/A
	LCDDATA04	I/O	LVC MOS	PR6 (15)		N/A
	M0PWM6	O	LVC MOS	PR6 (6)		N/A
	T1CCP0	I/O	LVC MOS	PR6 (3)		N/A
	U1Tx	O	LVC MOS	PR6 (1)		N/A
W10	PT0	I/O	LVC MOS	–	VDD	OFF
	CAN0Rx	I	LVC MOS	PT0 (7)		N/A
	EN0RXD0	I	LVC MOS	PT0 (14)		N/A
	LCDDATA10	I/O	LVC MOS	PT0 (15)		N/A
	T6CCP0	I/O	LVC MOS	PT0 (3)		N/A
W12	PQ5	I/O	LVC MOS	–	VDD	OFF
	EN0RXD0	I	LVC MOS	PQ5 (14)		N/A
	U1Tx	O	LVC MOS	PQ5 (1)		N/A
W13	EN0RXIP	I/O	LVC MOS	Fixed	VDD	N/A
W15	RBIAS	O	Analog	Fixed	VDD	N/A
W16	PK7	I/O	LVC MOS	–	VDD	OFF
	EN0TXD3	O	LVC MOS	PK7 (14)		N/A
	EPI0S24	I/O	LVC MOS	PK7 (15)		N/A
	I2C4SDA	I/O	LVC MOS	PK7 (2)		N/A
	M0FAULT2	I	LVC MOS	PK7 (6)		N/A
	RTCCLK	O	LVC MOS	PK7 (5)		N/A
	U0RI	I	LVC MOS	PK7 (1)		N/A
W18	NC	–	–	–	N/A	N/A
W19	NC	–	–	–	N/A	N/A



### 4.3 Signal Descriptions

表 4-3 describes the signals. The signals are sorted by function.

表 4-3. Signal Descriptions

FUNCTION	SIGNAL NAME	PIN NUMBER	PIN TYPE	DESCRIPTION
1-Wire	OWALT	K15	I/O	1-Wire optional second signal to be used as output
		B12		
	OWIRE	G2	I/O	1-Wire single bus pin. This signal is input only if 1-Wire alternate output is enabled
		K17		
		V12		
		U14		
		D8		
		A8		
ADC	AIN0		I	Analog-to-digital converter input 0
	AIN1			Analog-to-digital converter input 1
	AIN2			Analog-to-digital converter input 2
	AIN3			Analog-to-digital converter input 3
	AIN4			Analog-to-digital converter input 4
	AIN5			Analog-to-digital converter input 5
	AIN6			Analog-to-digital converter input 6
	AIN7			Analog-to-digital converter input 7
	AIN8			Analog-to-digital converter input 8
	AIN9			Analog-to-digital converter input 9
	AIN10			Analog-to-digital converter input 10
	AIN11			Analog-to-digital converter input 11
	AIN12			Analog-to-digital converter input 12
	AIN13			Analog-to-digital converter input 13
	AIN14			Analog-to-digital converter input 14
	AIN15			Analog-to-digital converter input 15
	AIN16			Analog-to-digital converter input 16
	AIN17			Analog-to-digital converter input 17
	AIN18			Analog-to-digital converter input 18
	AIN19			Analog-to-digital converter input 19
	AIN20			Analog-to-digital converter input 20
	AIN21			Analog-to-digital converter input 21
	AIN22			Analog-to-digital converter input 22
	AIN23			Analog-to-digital converter input 23
		VREFA+		
	VREFA-		A reference voltage used to specify the input voltage at which the ADC converts to a minimum value. This pin is used in conjunction with VREFA+, which specifies the maximum value. In other words, the voltage that is applied to VREFA- is the voltage with which an AINn signal is converted to 0, while the voltage that is applied to VREFA+ is the voltage with which an AINn signal is converted to 4095. The VREFA- voltage is limited to the range specified in 表 5-33.	

表 4-3. Signal Descriptions (continued)

FUNCTION	SIGNAL NAME	PIN NUMBER	PIN TYPE	DESCRIPTION
Analog Comparators	C0+	L2	I	Analog comparator 0 positive input
	C0-	K3	I	Analog comparator 0 negative input
	C0o	C2	O	Analog comparator 0 output
		G18		
	C1+	M1	I	Analog comparator 1 positive input
	C1-	M2	I	Analog comparator 1 negative input
	C1o	C1	O	Analog comparator 1 output
		J18		
	C2+	D6	I	Analog comparator 2 positive input
C2-	D7	I	Analog comparator 2 negative input	
C2o	D2	O	Analog comparator 2 output	
Controller Area Network	CAN0Rx	V3	I	CAN module 0 receive
		W10		
	CAN0Tx	W3	O	CAN module 0 transmit
		V10		
	CAN1Rx	A16	I	CAN module 1 receive
		E18		
	CAN1Tx	B16	O	CAN module 1 transmit
		F17		
Core	TRCLK	T7	O	Trace clock
	TRD0	W6		Trace data 0
	TRD1	V6		Trace data 1
	TRD2	U6		Trace data 2
	TRD3	V7		Trace data 3

表 4-3. Signal Descriptions (continued)

FUNCTION	SIGNAL NAME	PIN NUMBER	PIN TYPE	DESCRIPTION
Ethernet	EN0COL	N18	I	Ethernet 0 collision detect
	EN0CRS	N19	I	Ethernet 0 carrier sense
	EN0INTRN	U19	I	Ethernet 0 interrupt from the Ethernet PHY
		D6		
	EN0LED0	U6	O	Ethernet 0 LED 0
		U19		
	EN0LED1	V7	O	Ethernet 0 LED 1
		V16		
	EN0LED2	V6	O	Ethernet 0 LED 2
		V17		
	EN0MDC	A17	O	Ethernet 0 management data clock
		W6		
	EN0MDIO	B17	I/O	Ethernet 0 management data input/output signal
		T7		
	EN0PPS	N15	O	Ethernet 0 pulse-per-second (PPS) output
		T2		
		C8		
	EN0RREF_CLK	M18	I/O	Ethernet 0 reference clock
	EN0RXCK	V5	I	Ethernet 0 receive clock
	EN0RXD0	W12	I	Ethernet 0 receive data 0
		W10		
	EN0RXD1	U15	I	Ethernet 0 receive data 1
		V10		
	EN0RXD2	V17	I	Ethernet 0 receive data 2
	EN0RXD3	U19	I	Ethernet 0 receive data 3
	EN0RXDV	U14	I	Ethernet 0 receive data valid
		R13		
	EN0RXER	V12	I	Ethernet 0 receive error
		U10		
	EN0RXIN	V13	I/O	Ethernet PHY negative receive differential input
	EN0RXIP	W13	I/O	Ethernet PHY positive receive differential input
	EN0TXCK	V11	I/O	Ethernet 0 transmit clock
	EN0TXD0	K17	O	Ethernet 0 transmit data 0
V9				
EN0TXD1	K15	O	Ethernet 0 transmit data 1	
	T13			
EN0TXD2	V16	O	Ethernet 0 transmit data 2	
EN0TXD3	W16	O	Ethernet 0 transmit data 3	
EN0TXEN	M16	O	Ethernet 0 transmit enable	
	R10			
EN0TXER	T12	O	Ethernet 0 transmit error	
EN0TXON	V14	I/O	Ethernet PHY negative transmit differential output	
EN0TXOP	V15	I/O	Ethernet PHY positive transmit differential output	
RBIAS	W15	O	4.87-kΩ resistor (1% precision) for Ethernet PHY	

表 4-3. Signal Descriptions (continued)

FUNCTION	SIGNAL NAME	PIN NUMBER	PIN TYPE	DESCRIPTION
External Peripheral Interface	EPI0S0	P4	I/O	EPI module 0 signal 0
		J1		
	EPI0S1	R2	I/O	EPI module 0 signal 1
		J2		
	EPI0S2	R1	I/O	EPI module 0 signal 2
		K1		
	EPI0S3	T1	I/O	EPI module 0 signal 3
		K2		
	EPI0S4	K3	I/O	EPI module 0 signal 4
	EPI0S5	L2	I/O	EPI module 0 signal 5
	EPI0S6	M1	I/O	EPI module 0 signal 6
	EPI0S7	M2	I/O	EPI module 0 signal 7
	EPI0S8	V5	I/O	EPI module 0 signal 8
	EPI0S9	R7	I/O	EPI module 0 signal 9
	EPI0S10	T14	I/O	EPI module 0 signal 10
	EPI0S11	N15	I/O	EPI module 0 signal 11
	EPI0S12	L19	I/O	EPI module 0 signal 12
	EPI0S13	L18	I/O	EPI module 0 signal 13
	EPI0S14	K19	I/O	EPI module 0 signal 14
	EPI0S15	K18	I/O	EPI module 0 signal 15
	EPI0S16	G16	I/O	EPI module 0 signal 16
	EPI0S17	H19	I/O	EPI module 0 signal 17
	EPI0S18	G18	I/O	EPI module 0 signal 18
	EPI0S19	J18	I/O	EPI module 0 signal 19
	EPI0S20	E3	I/O	EPI module 0 signal 20
	EPI0S21	E2	I/O	EPI module 0 signal 21
	EPI0S22	H4	I/O	EPI module 0 signal 22
	EPI0S23	M4	I/O	EPI module 0 signal 23
	EPI0S24	W16	I/O	EPI module 0 signal 24
	EPI0S25	V16	I/O	EPI module 0 signal 25
	EPI0S26	H18	I/O	EPI module 0 signal 26
	EPI0S27	A17	I/O	EPI module 0 signal 27
	EPI0S28	B17	I/O	EPI module 0 signal 28
	EPI0S29	A11	I/O	EPI module 0 signal 29
		B13		
EPI0S30	B10	I/O	EPI module 0 signal 30	
	C12			
EPI0S31	V17	I/O	EPI module 0 signal 31	
EPI0S32	U19	I/O	EPI module 0 signal 32	
EPI0S33	G19	I/O	EPI module 0 signal 33	
EPI0S34	A10	I/O	EPI module 0 signal 34	
EPI0S35	B9	I/O	EPI module 0 signal 35	

**表 4-3. Signal Descriptions (continued)**

FUNCTION	SIGNAL NAME	PIN NUMBER	PIN TYPE	DESCRIPTION	
General-Purpose Timers	T0CCP0	V3	I/O	16- and 32-bit Timer 0 capture, compare, or PWM 0	
		C2			
		H18			
		P3			
	T0CCP1	T0CCP1	W3	I/O	16- and 32-bit Timer 0 capture, compare, or PWM 1
			C1		
			G19		
			P2		
	T1CCP0	T1CCP0	T6	I/O	16- and 32-bit Timer 1 capture, compare, or PWM 0
			D2		
			C18		
			W9		
	T1CCP1	T1CCP1	U5	I/O	16- and 32-bit Timer 1 capture, compare, or PWM 1
			D1		
			B18		
			R10		
	T2CCP0	T2CCP0	V4	I/O	16- and 32-bit Timer 2 capture, compare, or PWM 0
			K18		
			D12		
	T2CCP1	T2CCP1	W4	I/O	16- and 32-bit Timer 2 capture, compare, or PWM 1
			K19		
			D13		
	T3CCP0	T3CCP0	V5	I/O	16- and 32-bit Timer 3 capture, compare, or PWM 0
			A4		
			L18		
			B14		
	T3CCP1	T3CCP1	R7	I/O	16- and 32-bit Timer 3 capture, compare, or PWM 1
			B4		
			L19		
			A14		
	T4CCP0	T4CCP0	A16	I/O	16- and 32-bit Timer 4 capture, compare, or PWM 0
			B3		
M18					
V9					
T4CCP1	T4CCP1	B16	I/O	16- and 32-bit Timer 4 capture, compare, or PWM 1	
		B2			
		G15			
		T13			

表 4-3. Signal Descriptions (continued)

FUNCTION	SIGNAL NAME	PIN NUMBER	PIN TYPE	DESCRIPTION
General-Purpose Timers (continued)	T5CCP0	A17	I/O	16- and 32-bit Timer 5 capture, compare, or PWM 0
		N19		
		U10		
	T5CCP1	B17	I/O	16- and 32-bit Timer 5 capture, compare, or PWM 1
		N18		
		R13		
	T6CCP0	F2	I/O	16- and 32-bit Timer 6 capture, compare, or PWM 0
		D6		
		E3		
		W10		
	T6CCP1	F1	I/O	16- and 32-bit Timer 6 capture, compare, or PWM 1
		D7		
		E2		
		V10		
T7CCP0	M2	I/O	16- and 32-bit Timer 7 capture, compare, or PWM 0	
	H4			
	E18			
T7CCP1	M1	I/O	16- and 32-bit Timer 7 capture, compare, or PWM 1	
	M4			
	F17			
GPIO, Port A	PA0	V3	I/O	GPIO port A bit 0
	PA1	W3	I/O	GPIO port A bit 1
	PA2	T6	I/O	GPIO port A bit 2
	PA3	U5	I/O	GPIO port A bit 3
	PA4	V4	I/O	GPIO port A bit 4
	PA5	W4	I/O	GPIO port A bit 5
	PA6	V5	I/O	GPIO port A bit 6
	PA7	R7	I/O	GPIO port A bit 7
GPIO, Port B	PB0	A16	I/O	GPIO port B bit 0
	PB1	B16	I/O	GPIO port B bit 1
	PB2	A17	I/O	GPIO port B bit 2
	PB3	B17	I/O	GPIO port B bit 3
	PB4	C6	I/O	GPIO port B bit 4
	PB5	B6	I/O	GPIO port B bit 5
	PB6	F2	I/O	GPIO port B bit 6
	PB7	F1	I/O	GPIO port B bit 7
GPIO, Port C	PC0	B15	I/O	GPIO port C bit 0
	PC1	C15	I/O	GPIO port C bit 1
	PC2	D14	I/O	GPIO port C bit 2
	PC3	C14	I/O	GPIO port C bit 3
	PC4	M2	I/O	GPIO port C bit 4
	PC5	M1	I/O	GPIO port C bit 5
	PC6	L2	I/O	GPIO port C bit 6
	PC7	K3	I/O	GPIO port C bit 7

**表 4-3. Signal Descriptions (continued)**

FUNCTION	SIGNAL NAME	PIN NUMBER	PIN TYPE	DESCRIPTION
GPIO, Port D	PD0	C2	I/O	GPIO port D bit 0
	PD1	C1	I/O	GPIO port D bit 1
	PD2	D2	I/O	GPIO port D bit 2
	PD3	D1	I/O	GPIO port D bit 3
	PD4	A4	I/O	GPIO port D bit 4
	PD5	B4	I/O	GPIO port D bit 5
	PD6	B3	I/O	GPIO port D bit 6
	PD7	B2	I/O	GPIO port D bit 7
GPIO, Port E	PE0	H3	I/O	GPIO port E bit 0
	PE1	H2	I/O	GPIO port E bit 1
	PE2	G1	I/O	GPIO port E bit 2
	PE3	G2	I/O	GPIO port E bit 3
	PE4	A5	I/O	GPIO port E bit 4
	PE5	B5	I/O	GPIO port E bit 5
	PE6	A7	I/O	GPIO port E bit 6
	PE7	B7	I/O	GPIO port E bit 7
GPIO, Port F	PF0	U6	I/O	GPIO port F bit 0
	PF1	V6	I/O	GPIO port F bit 1
	PF2	W6	I/O	GPIO port F bit 2
	PF3	T7	I/O	GPIO port F bit 3
	PF4	V7	I/O	GPIO port F bit 4
	PF5	W7	I/O	GPIO port F bit 5
	PF6	T8	I/O	GPIO port F bit 6
	PF7	U8	I/O	GPIO port F bit 7
GPIO, Port G	PG0	N15	I/O	GPIO port G bit 0
	PG1	T14	I/O	GPIO port G bit 1
	PG2	V11	I/O	GPIO port G bit 2
	PG3	M16	I/O	GPIO port G bit 3
	PG4	K17	I/O	GPIO port G bit 4
	PG5	K15	I/O	GPIO port G bit 5
	PG6	V12	I/O	GPIO port G bit 6
	PG7	U14	I/O	GPIO port G bit 7
GPIO, Port H	PH0	P4	I/O	GPIO port H bit 0
	PH1	R2	I/O	GPIO port H bit 1
	PH2	R1	I/O	GPIO port H bit 2
	PH3	T1	I/O	GPIO port H bit 3
	PH4	R3	I/O	GPIO port H bit 4
	PH5	T2	I/O	GPIO port H bit 5
	PH6	U2	I/O	GPIO port H bit 6
	PH7	V2	I/O	GPIO port H bit 7

表 4-3. Signal Descriptions (continued)

FUNCTION	SIGNAL NAME	PIN NUMBER	PIN TYPE	DESCRIPTION
GPIO, Port J	PJ0	C8	I/O	GPIO port J bit 0
	PJ1	E7	I/O	GPIO port J bit 1
	PJ2	H17	I/O	GPIO port J bit 2
	PJ3	F16	I/O	GPIO port J bit 3
	PJ4	F18	I/O	GPIO port J bit 4
	PJ5	E17	I/O	GPIO port J bit 5
	PJ6	N1	I/O	GPIO port J bit 6
	PJ7	K5	I/O	GPIO port J bit 7
GPIO, Port K	PK0	J1	I/O	GPIO port K bit 0
	PK1	J2	I/O	GPIO port K bit 1
	PK2	K1	I/O	GPIO port K bit 2
	PK3	K2	I/O	GPIO port K bit 3
	PK4	U19	I/O	GPIO port K bit 4
	PK5	V17	I/O	GPIO port K bit 5
	PK6	V16	I/O	GPIO port K bit 6
	PK7	W16	I/O	GPIO port K bit 7
GPIO, Port L	PL0	G16	I/O	GPIO port L bit 0
	PL1	H19	I/O	GPIO port L bit 1
	PL2	G18	I/O	GPIO port L bit 2
	PL3	J18	I/O	GPIO port L bit 3
	PL4	H18	I/O	GPIO port L bit 4
	PL5	G19	I/O	GPIO port L bit 5
	PL6	C18	I/O	GPIO port L bit 6
	PL7	B18	I/O	GPIO port L bit 7
GPIO, Port M	PM0	K18	I/O	GPIO port M bit 0
	PM1	K19	I/O	GPIO port M bit 1
	PM2	L18	I/O	GPIO port M bit 2
	PM3	L19	I/O	GPIO port M bit 3
	PM4	M18	I/O	GPIO port M bit 4
	PM5	G15	I/O	GPIO port M bit 5
	PM6	N19	I/O	GPIO port M bit 6
	PM7	N18	I/O	GPIO port M bit 7
GPIO, Port N	PN0	C10	I/O	GPIO port N bit 0
	PN1	B11	I/O	GPIO port N bit 1
	PN2	A11	I/O	GPIO port N bit 2
	PN3	B10	I/O	GPIO port N bit 3
	PN4	A10	I/O	GPIO port N bit 4
	PN5	B9	I/O	GPIO port N bit 5
	PN6	T12	I/O	GPIO port N bit 6
	PN7	U12	I/O	GPIO port N bit 7



**表 4-3. Signal Descriptions (continued)**

FUNCTION	SIGNAL NAME	PIN NUMBER	PIN TYPE	DESCRIPTION
GPIO, Port P	PP0	D6	I/O	GPIO port P bit 0
	PP1	D7	I/O	GPIO port P bit 1
	PP2	B13	I/O	GPIO port P bit 2
	PP3	C12	I/O	GPIO port P bit 3
	PP4	D8	I/O	GPIO port P bit 4
	PP5	B12	I/O	GPIO port P bit 5
	PP6	B8	I/O	GPIO port P bit 6
	PP7	A8	I/O	GPIO port P bit 7
GPIO, Port Q	PQ0	E3	I/O	GPIO port Q bit 0
	PQ1	E2	I/O	GPIO port Q bit 1
	PQ2	H4	I/O	GPIO port Q bit 2
	PQ3	M4	I/O	GPIO port Q bit 3
	PQ4	A13	I/O	GPIO port Q bit 4
	PQ5	W12	I/O	GPIO port Q bit 5
	PQ6	U15	I/O	GPIO port Q bit 6
	PQ7	M3	I/O	GPIO port Q bit 7
GPIO, Port R	PR0	N5	I/O	GPIO port R bit 0
	PR1	N4	I/O	GPIO port R bit 1
	PR2	N2	I/O	GPIO port R bit 2
	PR3	V8	I/O	GPIO port R bit 3
	PR4	P3	I/O	GPIO port R bit 4
	PR5	P2	I/O	GPIO port R bit 5
	PR6	W9	I/O	GPIO port R bit 6
	PR7	R10	I/O	GPIO port R bit 7
GPIO, Port S	PS0	D12	I/O	GPIO port S bit 0
	PS1	D13	I/O	GPIO port S bit 1
	PS2	B14	I/O	GPIO port S bit 2
	PS3	A14	I/O	GPIO port S bit 3
	PS4	V9	I/O	GPIO port S bit 4
	PS5	T13	I/O	GPIO port S bit 5
	PS6	U10	I/O	GPIO port S bit 6
	PS7	R13	I/O	GPIO port S bit 7
GPIO, Port T	PT0	W10	I/O	GPIO port T bit 0
	PT1	V10	I/O	GPIO port T bit 1
	PT2	E18	I/O	GPIO port T bit 2
	PT3	F17	I/O	GPIO port T bit 3

表 4-3. Signal Descriptions (continued)

FUNCTION	SIGNAL NAME	PIN NUMBER	PIN TYPE	DESCRIPTION	
Hibernate	GNDX	R18	–	GND for the Hibernation oscillator. When using a crystal clock source, connect this pin to digital ground along with the crystal load capacitors. When using an external oscillator, connect this pin to digital ground.	
	$\overline{\text{HIB}}$	M17	O	An output that indicates the processor is in hibernate mode.	
	RTCCLK	M1	O	O	Buffered version of the 32.768-kHz clock of the Hibernation module. This signal is not output when the part is in hibernate mode and before being configured after power-on reset.
		W16			
		C12			
	TMPR0	N18	I/O	Tamper signal 0	
	TMPR1	N19	I/O	Tamper signal 1	
	TMPR2	G15	I/O	Tamper signal 2	
	TMPR3	M18	I/O	Tamper signal 3	
	VBAT	P19	–	Power source for the Hibernation module. It is normally connected to the positive terminal of a battery and serves as the battery backup and Hibernation module power-source supply.	
	$\overline{\text{WAKE}}$	U18	I	An external input that brings the processor out of hibernate mode when asserted	
XOSC0	T18	I	Hibernation module oscillator crystal input or an external clock reference input. This is either a crystal or a 32.768-kHz oscillator for the RTC of the Hibernation module.		
XOSC1	T19	O	Hibernation module oscillator crystal output. Leave unconnected when using a single-ended clock source.		

**表 4-3. Signal Descriptions (continued)**

FUNCTION	SIGNAL NAME	PIN NUMBER	PIN TYPE	DESCRIPTION	
I <sup>2</sup> C	I2C0SCL	A17	I/O	I <sup>2</sup> C module 0 clock. This signal has an active pullup. The corresponding port pin should not be configured as open drain.	
	I2C0SDA	B17	I/O	I <sup>2</sup> C module 0 data	
	I2C1SCL	N15	I/O		I <sup>2</sup> C module 1 clock. This signal has an active pullup. The corresponding port pin should not be configured as open drain.
		N5			
	I2C1SDA	T14	I/O		I <sup>2</sup> C module 1 data
		N4			
	I2C2SCL	V11	I/O		I <sup>2</sup> C module 2 clock. This signal has an active pullup. The corresponding port pin should not be configured as open drain.
		H19			
		B9			
		B12			
	I2C2SDA	M16	I/O		I <sup>2</sup> C module 2 data
		G16			
		A10			
		B8			
	I2C3SCL	K17	I/O		I <sup>2</sup> C module 3 clock. This signal has an active pullup. The corresponding port pin should not be configured as open drain.
		U19			
		P3			
	I2C3SDA	K15	I/O		I <sup>2</sup> C module 3 data
		V17			
	I2C4SCL	P2	I/O		I <sup>2</sup> C module 4 clock. This signal has an active pullup. The corresponding port pin should not be configured as open drain.
		V12			
		V16			
	I2C4SDA	W9	I/O		I <sup>2</sup> C module 4 data
		U14			
		W16			
	I2C5SCL	R10	I/O		I <sup>2</sup> C module 5 clock. This signal has an active pullup. The corresponding port pin should not be configured as open drain.
		A16			
	I2C5SDA	C6	I/O		I <sup>2</sup> C module 5 data
B16					
I2C6SCL	B6	I/O		I <sup>2</sup> C module 6 clock. This signal has an active pullup. The corresponding port pin should not be configured as open drain.	
	V5				
I2C6SDA	F2	I/O		I <sup>2</sup> C module 6 data	
	R7				
I2C7SCL	F1	I/O		I <sup>2</sup> C module 7 clock. This signal has an active pullup. The corresponding port pin should not be configured as open drain.	
	V4				
I2C7SDA	C2	I/O		I <sup>2</sup> C module 7 data	
	W4				
I2C8SCL	C1	I/O		I <sup>2</sup> C module 8 clock. This signal has an active pullup. The corresponding port pin should not be configured as open drain.	
	T6				
I2C8SDA	D2	I/O		I <sup>2</sup> C module 8 data	
	U5				
	D1	I/O			

表 4-3. Signal Descriptions (continued)

FUNCTION	SIGNAL NAME	PIN NUMBER	PIN TYPE	DESCRIPTION
I <sup>2</sup> C (continued)	I2C9SCL	V3	I/O	I <sup>2</sup> C module 9 clock. This signal has an active pullup. The corresponding port pin should not be configured as open drain.
		A7		
	I2C9SDA	W3	I/O	I <sup>2</sup> C module 9 data
		B7		
JTAG, SWD, SWO	TCLK/SWCLK	B15	I	JTAG and SWD clock
	TDI	D14	I	JTAG TDI
	TDO/SWO	C14	O	JTAG TDO and SWO
	TMS/SWDIO	C15	I	JTAG TMS and SWDIO
LCD	LCDAC	N1	O	LCD AC bias or latch enable in raster mode. Primary chip select (CS0) or primary enable (E0) in LIDD MPU/Hitachi mode.
	LCDCP	N5	O	LCD pixel clock in raster mode. Read strobe or read/write strobe in LIDD mode.
	LCDDATA00	P3	I/O	LCD data pin 0 input/output
	LCDDATA01	P2	I/O	LCD data pin 1 input/output
	LCDDATA02	U8	I/O	LCD data pin 2 input/output
	LCDDATA03	V8	I/O	LCD data pin 3 input/output
	LCDDATA04	W9	I/O	LCD data pin 4 input/output
	LCDDATA05	R10	I/O	LCD data pin 5 input/output
	LCDDATA06	V9	I/O	LCD data pin 6 input/output
	LCDDATA07	T13	I/O	LCD data pin 7 input/output
	LCDDATA08	U10	I/O	LCD data pin 8 input/output
	LCDDATA09	R13	I/O	LCD data pin 9 input/output
	LCDDATA10	W10	I/O	LCD data pin 10 input/output
	LCDDATA11	V10	I/O	LCD data pin 11 input/output
	LCDDATA12	U12	I/O	LCD data pin 12 input/output
	LCDDATA13	T12	I/O	LCD data pin 13 input/output
	LCDDATA14	H17	I/O	LCD data pin 14 input/output
	LCDDATA15	F16	I/O	LCD data pin 15 input/output
	LCDDATA16	F18	O	LCD data pin 16 output
	LCDDATA17	E17	O	LCD data pin 17 output
	LCDDATA18	E18	O	LCD data pin 18 output
	LCDDATA19	F17	O	LCD data pin 19 output
	LCDDATA20	D12	O	LCD data pin 20 output
	LCDDATA21	D13	O	LCD data pin 21 output
	LCDDATA22	B14	O	LCD data pin 22 output
	LCDDATA23	A14	O	LCD data pin 23 output
	LCDFP	N4	O	LCD frame clock or VSYNC in raster mode. Address latch enable in LIDD mode.
	LCDLP	N2	O	LCD line clock or HSYNC in raster mode. Write strobe or direction bit in LIDD mode.
	LCDMCLK	T8	O	LCD memory clock, secondary chip select (CS1), or secondary enable (E1) in LIDD synchronous or asynchronous MPU or Hitachi mode

**表 4-3. Signal Descriptions (continued)**

FUNCTION	SIGNAL NAME	PIN NUMBER	PIN TYPE	DESCRIPTION					
PWM	M0FAULT0	V7	I	Motion control module 0 PWM fault 0					
		D12							
	M0FAULT1	V16		I	Motion control module 0 PWM fault 1				
		D13							
	M0FAULT2	W16			I	Motion control module 0 PWM fault 2			
		B14							
	M0FAULT3	G16	I			Motion control module 0 PWM fault 3			
		A14							
	M0PWM0	U6		O		Motion control module 0 PWM 0. This signal is controlled by module 0 PWM generator 0.			
		N5							
	M0PWM1	V6			O	Motion control module 0 PWM 1. This signal is controlled by module 0 PWM generator 0.			
		N4							
	M0PWM2	W6	O			Motion control module 0 PWM 2. This signal is controlled by module 0 PWM generator 1.			
		N2							
	M0PWM3	T7				O	Motion control module 0 PWM 3. This signal is controlled by module 0 PWM generator 1.		
		V8							
	M0PWM4	N15					O	Motion control module 0 PWM 4. This signal is controlled by module 0 PWM generator 2.	
		P3							
	M0PWM5	T14						O	Motion control module 0 PWM 5. This signal is controlled by module 0 PWM generator 2.
		P2							
M0PWM6	U19	O							Motion control module 0 PWM 6. This signal is controlled by module 0 PWM generator 3.
	W9								
M0PWM7	V17			O					Motion control module 0 PWM 7. This signal is controlled by module 0 PWM generator 3.
	R10								

表 4-3. Signal Descriptions (continued)

FUNCTION	SIGNAL NAME	PIN NUMBER	PIN TYPE	DESCRIPTION
Power	GND	F10	-	Ground reference for logic and I/O pins
		H10		
		H11		
		H12		
		J11		
		J12		
		K6		
		K9		
		P16		
		K10		
		R17		
		K13		
		K14		
		L8		
		L9		
		M8		
		M9		
		M10		
		N10		
		A1		
		A2		
		B1		
		V1		
		W1		
W2				
A18				
A19				
B19				

**表 4-3. Signal Descriptions (continued)**

FUNCTION	SIGNAL NAME	PIN NUMBER	PIN TYPE	DESCRIPTION
Power (continued)	GND A	G4	–	The ground reference for the analog circuits (ADC, Analog Comparators, and so on). These are separated from GND to minimize the electrical noise contained on VDD from affecting the analog functions.
	VDD	G10	–	Positive supply for I/O and some logic
		H9		
		J8		
		J9		
		J10		
		K7		
		K8		
		K11		
		N16		
		P17		
		K12		
		L10		
		L11		
		L12		
	M11			
	M12			
P10				
VDDA	F3	–	The positive supply for the analog circuits (for example, ADC and analog comparators). These are separated from VDD to minimize the electrical noise contained on VDD from affecting the analog functions. VDDA pins must be supplied with a voltage that meets the specification in <a href="#">Section 5.4</a> , regardless of system implementation.	
VDDC	H16	–	Positive supply for most of the logic function, including the processor core and most peripherals. The voltage on this pin is 1.2 V and is supplied by the on-chip LDO. The VDDC pins should only be connected to each other and an external capacitor as specified in <a href="#">Section 5.12</a> .	
	E10			
QE1	IDX0	J18	I	QE1 module 0 index
		U10		
	PhA0	H19	I	QE1 module 0 phase A
		V9		
	PhB0	G18	I	QE1 module 0 phase B
		T13		

表 4-3. Signal Descriptions (continued)

FUNCTION	SIGNAL NAME	PIN NUMBER	PIN TYPE	DESCRIPTION		
SSI	SSI0Clk	T6	I/O	SSI module 0 clock		
	SSI0Fss	U5		SSI module 0 frame signal		
	SSI0XDAT0	V4		SSI Module 0 bidirectional data pin 0 (SSI0TX in Legacy SSI Mode)		
	SSI0XDAT1	W4		SSI Module 0 bidirectional data pin 1 (SSI0RX in Legacy SSI Mode)		
	SSI0XDAT2	V5		SSI Module 0 bidirectional data pin 2		
	SSI0XDAT3	R7		SSI Module 0 bidirectional data pin 3		
	SSI1Clk	B6		SSI module 1 clock		
	SSI1Fss	C6		SSI module 1 frame signal		
	SSI1XDAT0	A5		SSI Module 1 bidirectional data pin 0 (SSI1TX in Legacy SSI Mode)		
	SSI1XDAT1	B5		SSI Module 1 bidirectional data pin 1 (SSI1RX in Legacy SSI Mode)		
	SSI1XDAT2	A4		SSI Module 1 bidirectional data pin 2		
	SSI1XDAT3	B4		SSI Module 1 bidirectional data pin 3		
	SSI2Clk			D1		SSI module 2 clock
				U14		
	SSI2Fss			D2		SSI module 2 frame signal
				V12		
	SSI2XDAT0			C1		SSI Module 2 bidirectional data pin 0 (SSI2TX in Legacy SSI Mode)
				K15		
	SSI2XDAT1			C2		SSI Module 2 bidirectional data pin 1 (SSI2RX in Legacy SSI Mode)
				K17		
	SSI2XDAT2			B2		SSI Module 2 bidirectional data pin 2
				M16		
	SSI2XDAT3			B3		SSI Module 2 bidirectional data pin 3
				V11		
	SSI3Clk			T7		SSI module 3 clock
				E3		
	SSI3Fss			W6		SSI module 3 frame signal
				E2		
	SSI3XDAT0			V6		SSI Module 3 bidirectional data pin 0 (SSI3TX in Legacy SSI Mode)
				H4		
	SSI3XDAT1			U6		SSI Module 3 bidirectional data pin 1 (SSI3RX in Legacy SSI Mode)
				M4		
SSI3XDAT2		V7		SSI Module 3 bidirectional data pin 2		
		D6				
SSI3XDAT3		W7		SSI Module 3 bidirectional data pin 3		
		D7				



**表 4-3. Signal Descriptions (continued)**

FUNCTION	SIGNAL NAME	PIN NUMBER	PIN TYPE	DESCRIPTION
System Control and Clocks	DIVSCLK	A13	O	An optionally divided reference clock output based on a selected clock source. This signal is not synchronized to the system clock.
	GNDX2	D18	–	GND for the MOSC. When using a crystal clock source, connect this pin to digital ground along with the crystal load capacitors. When using an external oscillator, connect this pin to digital ground.
	NMI	B2	I	Nonmaskable interrupt
		B7		
	OSC0	E19		Main oscillator crystal input or an external clock reference input
	OSC1	D19	O	Main oscillator crystal output. Leave unconnected when using a single-ended clock source.
	$\overline{\text{RST}}$	P18	I	System reset input

表 4-3. Signal Descriptions (continued)

FUNCTION	SIGNAL NAME	PIN NUMBER	PIN TYPE	DESCRIPTION
UART	U0CTS	C6	I	UART module 0 clear to send modem flow control input signal
		A7		
		K17		
		R2		
		M18		
	U0DCD	R1	I	UART module 0 data carrier detect modem status input signal
		G15		
		C12		
	U0DSR	T1	I	UART module 0 data set ready modem output control line
		N19		
		D8		
	U0DTR	R3	O	UART module 0 data terminal ready modem status input signal
		B13		
	U0RI	T2	I	UART module 0 ring indicator modem status input signal
		W16		
		N18		
	U0RTS	B6	O	UART module 0 request to send modem flow control output signal
		B7		
		K15		
		P4		
	U0Rx	V3	I	UART module 0 receive
	U0Tx	W3	O	UART module 0 transmit
	U1CTS	B11	I	UART module 1 clear to send modem flow control input signal
		C12		
	U1DCD	G1	I	UART module 1 data carrier detect modem status input signal
		A11		
		B8		
	U1DSR	H2	I	UART module 1 data set ready modem output control line
		B10		
		B14		
	U1DTR	G2	O	UART module 1 data terminal ready modem status input signal
		A10		
U15				
U1RI	A5	I	UART module 1 ring indicator modem status input signal	
	B9			
	M3			
U1RTS	H3	O	UART module 1 request to send modem flow control output line	
	C10			
	U12			
U1Rx	A16	I	UART module 1 receive	
	A13			
	P2			
U1Tx	B16	O	UART module 1 transmit	
	W12			
	W9			

**表 4-3. Signal Descriptions (continued)**

FUNCTION	SIGNAL NAME	PIN NUMBER	PIN TYPE	DESCRIPTION
UART (continued)	U2CTS	B2	I	UART module 2 clear to send modem flow control input signal
		F16		
		B10		
	U2RTS	B3	O	UART module 2 request to send modem flow control output line
		H17		
		A11		
	U2Rx	V5	I	UART module 2 receive
		A4		
	U2Tx	R7	O	UART module 2 transmit
		B4		
	U3CTS	E17	I	UART module 3 clear to send modem flow control input signal
		B9		
		B12		
	U3RTS	F18	O	UART module 3 request to send modem flow control output line
		A10		
		D8		
	U3Rx	V4	I	UART module 3 receive
		C8		
	U3Tx	W4	O	UART module 3 transmit
		E7		
	U4CTS	K5	I	UART module 4 clear to send modem flow control input signal
		K2		
		U12		
	U4RTS	N1	O	UART module 4 request to send modem flow control output line
		K1		
		T12		
	U4Rx	T6	I	UART module 4 receive
		J1		
		N4		
	U4Tx	U5	O	UART module 4 transmit
J2				
N5				
U5Rx	L2	I	UART module 5 receive	
	U2			
U5Tx	K3	O	UART module 5 transmit	
	V2			
U6Rx	D6	I	UART module 6 receive	
U6Tx	D7	O	UART module 6 transmit	
U7Rx	M2	I	UART module 7 receive	
	U2			
U7Tx	M1	O	UART module 7 transmit	
	V2			

表 4-3. Signal Descriptions (continued)

FUNCTION	SIGNAL NAME	PIN NUMBER	PIN TYPE	DESCRIPTION	
USB	USB0CLK	B17	O	60-MHz clock to the external PHY	
	USB0D0	G16	I/O	USB data 0	
	USB0D1	H19		USB data 1	
	USB0D2	G18		USB data 2	
	USB0D3	J18		USB data 3	
	USB0D4	H18		USB data 4	
	USB0D5	G19		USB data 5	
	USB0D6	B12		USB data 6	
	USB0D7	D8		USB data 7	
	USB0DIR	C12	O	Indicates that the external PHY is able to accept data from the USB controller	
	USB0DM	B18	I/O	Bidirectional differential data pin (D– per USB specification) for USB0	
	USB0DP	C18		Bidirectional differential data pin (D+ per USB specification) for USB0	
	USB0EPEN		V5	O	Optionally used in host mode to control an external power source to supply power to the USB bus
			R7		
			B3		
	USB0ID	A16	I	This signal senses the state of the USB ID signal. The USB PHY enables an integrated pullup, and an external element (USB connector) indicates the initial state of the USB controller (pulled down is the A side of the cable and pulled up is the B side).	
	USB0NXT	B13	O	Asserted by the external PHY to throttle all data types	
USB0PFLT		R7	I	Optionally used in host mode by an external power source to indicate an error state by that power source	
		B2			
USB0STP	A17	O	Asserted by the USB controller to signal the end of a USB transmit packet or register write operation		
USB0VBUS	B16	I/O	This signal is used during the session request protocol. This signal allows the USB PHY to both sense the voltage level of VBUS, and pull up VBUS momentarily during VBUS pulsing.		

### 4.4 GPIO Pin Multiplexing

表 4-4 describes the GPIO pins and alternate functions.

表 4-4. GPIO Pins and Alternate Functions

I/O	PIN	ANALOG OR SPECIAL FUNCTION <sup>(1)</sup>	DIGITAL FUNCTION (GPIOCTL PMCx BIT FIELD ENCODING)											
			1	2	3	4	5	6	7	8	11	13	14	15
PA0	V3	–	U0Rx	I2C9SCL	T0CCP0	–	–	–	CAN0Rx	–	–	–	–	–
PA1	W3	–	U0Tx	I2C9SDA	T0CCP1	–	–	–	CAN0Tx	–	–	–	–	–
PA2	T6	–	U4Rx	I2C8SCL	T1CCP0	–	–	–	–	–	–	–	–	SSIOClk
PA3	U5	–	U4Tx	I2C8SDA	T1CCP1	–	–	–	–	–	–	–	–	SSIOFss
PA4	V4	–	U3Rx	I2C7SCL	T2CCP0	–	–	–	–	–	–	–	–	SSIOXDAT0
PA5	W4	–	U3Tx	I2C7SDA	T2CCP1	–	–	–	–	–	–	–	–	SSIOXDAT1
PA6	V5	–	U2Rx	I2C6SCL	T3CCP0	–	–	USB0EPEN	–	–	–	SSIOXDAT2	EN0RXCK	EPI0S8
PA7	R7	–	U2Tx	I2C6SDA	T3CCP1	–	–	USB0PFLT	–	–	–	SSIOXDAT3	–	EPI0S9
PB0	A16	USB0ID	U1Rx	I2C5SCL	T4CCP0	–	–	–	CAN1Rx	–	–	–	–	–
PB1	B16	USB0VBUS	U1Tx	I2C5SDA	T4CCP1	–	–	–	CAN1Tx	–	–	–	–	–
PB2	A17	–	–	I2C0SCL	T5CCP0	–	–	EN0MDC	–	–	–	–	USB0STP	EPI0S27
PB3	B17	–	–	I2C0SDA	T5CCP1	–	–	EN0MDIO	–	–	–	–	USB0CLK	EPI0S28
PB4	C6	AIN10	U0CTS	I2C5SCL	–	–	–	–	–	–	–	–	–	SSI1Fss
PB5	B6	AIN11	U0RTS	I2C5SDA	–	–	–	–	–	–	–	–	–	SSI1Clk
PB6	F2	–	–	I2C6SCL	T6CCP0	–	–	–	–	–	–	–	–	–
PB7	F1	–	–	I2C6SDA	T6CCP1	–	–	–	–	–	–	–	–	–
PC0	B15	–	TCLK SWCLK	–	–	–	–	–	–	–	–	–	–	–
PC1	C15	–	TMS SWDIO	–	–	–	–	–	–	–	–	–	–	–
PC2	D14	–	TDI	–	–	–	–	–	–	–	–	–	–	–
PC3	C14	–	TDO SWO	–	–	–	–	–	–	–	–	–	–	–
PC4	M2	C1-	U7Rx	–	T7CCP0	–	–	–	–	–	–	–	–	EPI0S7
PC5	M1	C1+	U7Tx	–	T7CCP1	–	–	–	–	–	–	–	–	EPI0S6
PC6	L2	C0+	U5Rx	–	–	–	–	–	–	–	–	–	–	EPI0S5
PC7	K3	C0-	U5Tx	–	–	–	–	–	–	–	–	–	–	EPI0S4
PD0	C2	AIN15	–	I2C7SCL	T0CCP0	–	–	C0o	–	–	–	–	–	SSI2XDAT1
PD1	C1	AIN14	–	I2C7SDA	T0CCP1	–	–	C1o	–	–	–	–	–	SSI2XDAT0
PD2	D2	AIN13	–	I2C8SCL	T1CCP0	–	–	C2o	–	–	–	–	–	SSI2Fss
PD3	D1	AIN12	–	I2C8SDA	T1CCP1	–	–	–	–	–	–	–	–	SSI2Clk
PD4	A4	AIN7	U2Rx	–	T3CCP0	–	–	–	–	–	–	–	–	SSI1XDAT2

(1) The TMPRn signals are digital signals enabled and configured by the Hibernation module. All other signals listed in this column are analog signals.

表 4-4. GPIO Pins and Alternate Functions (continued)

I/O	PIN	ANALOG OR SPECIAL FUNCTION <sup>(1)</sup>	DIGITAL FUNCTION (GPIOCTL PMCx BIT FIELD ENCODING)											
			1	2	3	4	5	6	7	8	11	13	14	15
PD5	B4	AIN6	U2Tx	–	T3CCP1	–	–	–	–	–	–	–	–	SSI1XDAT3
PD6	B3	AIN5	U2RTS	–	T4CCP0	–	USB0EPEN	–	–	–	–	–	–	SSI2XDAT3
PD7	B2	AIN4	U2CTS	–	T4CCP1	–	USB0PFLT	–	–	NMI	–	–	–	SSI2XDAT2
PE0	H3	AIN3	U1RTS	–	–	–	–	–	–	–	–	–	–	–
PE1	H2	AIN2	U1DSR	–	–	–	–	–	–	–	–	–	–	–
PE2	G1	AIN1	U1DCD	–	–	–	–	–	–	–	–	–	–	–
PE3	G2	AIN0	U1DTR	–	–	–	OWIRE	–	–	–	–	–	–	–
PE4	A5	AIN9	U1RI	–	–	–	–	–	–	–	–	–	–	SSI1XDAT0
PE5	B5	AIN8	–	–	–	–	–	–	–	–	–	–	–	SSI1XDAT1
PE6	A7	AIN20	U0CTS	I2C9SCL	–	–	–	–	–	–	–	–	–	–
PE7	B7	AIN21	U0RTS	I2C9SDA	–	–	–	–	–	NMI	–	–	–	–
PF0	U6	–	–	–	–	–	EN0LED0	M0PWM0	–	–	–	–	SSI3XDAT1	TRD2
PF1	V6	–	–	–	–	–	EN0LED2	M0PWM1	–	–	–	–	SSI3XDAT0	TRD1
PF2	W6	–	–	–	–	–	EN0MDC	M0PWM2	–	–	–	–	SSI3Fss	TRD0
PF3	T7	–	–	–	–	–	EN0MDIO	M0PWM3	–	–	–	–	SSI3Cik	TRCLK
PF4	V7	–	–	–	–	–	EN0LED1	M0FAULT0	–	–	–	–	SSI3XDAT2	TRD3
PF5	W7	–	–	–	–	–	–	–	–	–	–	–	SSI3XDAT3	–
PF6	T8	–	–	–	–	–	–	–	–	–	–	–	–	LCDMCLK
PF7	U8	–	–	–	–	–	–	–	–	–	–	–	–	LCDDATA0 2
PG0	N15	–	–	I2C1SCL	–	–	EN0PPS	M0PWM4	–	–	–	–	–	EPI0S11
PG1	T14	–	–	I2C1SDA	–	–	–	M0PWM5	–	–	–	–	–	EPI0S10
PG2	V11	–	–	I2C2SCL	–	–	–	–	–	–	–	–	EN0TXCK	SSI2XDAT3
PG3	M16	–	–	I2C2SDA	–	–	–	–	–	–	–	–	EN0TXEN	SSI2XDAT2
PG4	K17	–	U0CTS	I2C3SCL	–	–	OWIRE	–	–	–	–	–	EN0TXD0	SSI2XDAT1
PG5	K15	–	U0RTS	I2C3SDA	–	–	OWALT	–	–	–	–	–	EN0TXD1	SSI2XDAT0
PG6	V12	–	–	I2C4SCL	–	–	OWIRE	–	–	–	–	–	EN0RXER	SSI2Fss
PG7	U14	–	–	I2C4SDA	–	–	OWIRE	–	–	–	–	–	EN0RXDV	SSI2Cik
PH0	P4	–	U0RTS	–	–	–	–	–	–	–	–	–	–	EPI0S0
PH1	R2	–	U0CTS	–	–	–	–	–	–	–	–	–	–	EPI0S1
PH2	R1	–	U0DCD	–	–	–	–	–	–	–	–	–	–	EPI0S2
PH3	T1	–	U0DSR	–	–	–	–	–	–	–	–	–	–	EPI0S3
PH4	R3	–	U0DTR	–	–	–	–	–	–	–	–	–	–	–
PH5	T2	–	U0RI	–	–	–	EN0PPS	–	–	–	–	–	–	–
PH6	U2	–	U5Rx	U7Rx	–	–	–	–	–	–	–	–	–	–

表 4-4. GPIO Pins and Alternate Functions (continued)

I/O	PIN	ANALOG OR SPECIAL FUNCTION <sup>(1)</sup>	DIGITAL FUNCTION (GPIOCTL PMCx BIT FIELD ENCODING)											
			1	2	3	4	5	6	7	8	11	13	14	15
PH7	V2	–	U5Tx	U7Tx	–	–	–	–	–	–	–	–	–	–
PJ0	C8	–	U3Rx	–	–	–	ENOPPS	–	–	–	–	–	–	–
PJ1	E7	–	U3Tx	–	–	–	–	–	–	–	–	–	–	–
PJ2	H17	–	U2RTS	–	–	–	–	–	–	–	–	–	–	LCDDATA1 4
PJ3	F16	–	U2CTS	–	–	–	–	–	–	–	–	–	–	LCDDATA1 5
PJ4	F18	–	U3RTS	–	–	–	–	–	–	–	–	–	–	LCDDATA1 6
PJ5	E17	–	U3CTS	–	–	–	–	–	–	–	–	–	–	LCDDATA1 7
PJ6	N1	–	U4RTS	–	–	–	–	–	–	–	–	–	–	LCDAC
PJ7	K5	–	U4CTS	–	–	–	–	–	–	–	–	–	–	–
PK0	J1	AIN16	U4Rx	–	–	–	–	–	–	–	–	–	–	EPIOS0
PK1	J2	AIN17	U4Tx	–	–	–	–	–	–	–	–	–	–	EPIOS1
PK2	K1	AIN18	U4RTS	–	–	–	–	–	–	–	–	–	–	EPIOS2
PK3	K2	AIN19	U4CTS	–	–	–	–	–	–	–	–	–	–	EPIOS3
PK4	U19	–	–	I2C3SCL	–	–	EN0LED0	M0PWM6	EN0INTRN	–	–	–	EN0RXD3	EPIOS32
PK5	V17	–	–	I2C3SDA	–	–	EN0LED2	M0PWM7	–	–	–	–	EN0RXD2	EPIOS31
PK6	V16	–	–	I2C4SCL	–	–	EN0LED1	M0FAULT1	–	–	–	–	EN0TXD2	EPIOS25
PK7	W16	–	U0RI	I2C4SDA	–	–	RTCCLK	M0FAULT2	–	–	–	–	EN0TXD3	EPIOS24
PL0	G16	–	–	I2C2SDA	–	–	–	M0FAULT3	–	–	–	–	USB0D0	EPIOS16
PL1	H19	–	–	I2C2SCL	–	–	–	PhA0	–	–	–	–	USB0D1	EPIOS17
PL2	G18	–	–	–	–	–	C0o	PhB0	–	–	–	–	USB0D2	EPIOS18
PL3	J18	–	–	–	–	–	C1o	IDX0	–	–	–	–	USB0D3	EPIOS19
PL4	H18	–	–	–	T0CCP0	–	–	–	–	–	–	–	USB0D4	EPIOS26
PL5	G19	–	–	–	T0CCP1	–	–	–	–	–	–	–	USB0D5	EPIOS33
PL6	C18	USB0DP	–	–	T1CCP0	–	–	–	–	–	–	–	–	–
PL7	B18	USB0DM	–	–	T1CCP1	–	–	–	–	–	–	–	–	–
PM0	K18	–	–	–	T2CCP0	–	–	–	–	–	–	–	–	EPIOS15
PM1	K19	–	–	–	T2CCP1	–	–	–	–	–	–	–	–	EPIOS14
PM2	L18	–	–	–	T3CCP0	–	–	–	–	–	–	–	–	EPIOS13
PM3	L19	–	–	–	T3CCP1	–	–	–	–	–	–	–	–	EPIOS12
PM4	M18	TMPR3	U0CTS	–	T4CCP0	–	–	–	–	–	–	–	EN0RREF_ CLK	–
PM5	G15	TMPR2	U0DCD	–	T4CCP1	–	–	–	–	–	–	–	–	–
PM6	N19	TMPR1	U0DSR	–	T5CCP0	–	–	–	–	–	–	–	EN0CRS	–

表 4-4. GPIO Pins and Alternate Functions (continued)

I/O	PIN	ANALOG OR SPECIAL FUNCTION <sup>(1)</sup>	DIGITAL FUNCTION (GPIOCTL PMCx BIT FIELD ENCODING)												
			1	2	3	4	5	6	7	8	11	13	14	15	
PM7	N18	TMPRO	U0RI	–	T5CCP1	–	–	–	–	–	–	–	–	ENOCOL	–
PN0	C10	–	U1RTS	–	–	–	–	–	–	–	–	–	–	–	–
PN1	B11	–	U1CTS	–	–	–	–	–	–	–	–	–	–	–	–
PN2	A11	–	U1DCD	U2RTS	–	–	–	–	–	–	–	–	–	–	EPIOS29
PN3	B10	–	U1DSR	U2CTS	–	–	–	–	–	–	–	–	–	–	EPIOS30
PN4	A10	–	U1DTR	U3RTS	I2C2SDA	–	–	–	–	–	–	–	–	–	EPIOS34
PN5	B9	–	U1RI	U3CTS	I2C2SCL	–	–	–	–	–	–	–	–	–	EPIOS35
PN6	T12	–	–	U4RTS	–	–	–	–	–	–	–	–	–	EN0TXER	LCDDATA1 3
PN7	U12	–	U1RTS	U4CTS	–	–	–	–	–	–	–	–	–	–	LCDDATA1 2
PP0	D6	C2+	U6Rx	–	–	–	T6CCP0	–	EN0INTRN	–	–	–	–	–	SSI3XDAT2
PP1	D7	C2-	U6Tx	–	–	–	T6CCP1	–	–	–	–	–	–	–	SSI3XDAT3
PP2	B13	–	U0DTR	–	–	–	–	–	–	–	–	–	–	USB0NXT	EPIOS29
PP3	C12	–	U1CTS	U0DCD	–	–	–	–	RTCCLK	–	–	–	–	USB0DIR	EPIOS30
PP4	D8	–	U3RTS	U0DSR	–	OWIRE	–	–	–	–	–	–	–	USB0D7	–
PP5	B12	–	U3CTS	I2C2SCL	–	OWALT	–	–	–	–	–	–	–	USB0D6	–
PP6	B8	AIN23	U1DCD	I2C2SDA	–	–	–	–	–	–	–	–	–	–	–
PP7	A8	AIN22	–	–	–	–	OWIRE	–	–	–	–	–	–	–	–
PQ0	E3	–	–	–	T6CCP0	–	–	–	–	–	–	–	–	SSI3Clk	EPIOS20
PQ1	E2	–	–	–	T6CCP1	–	–	–	–	–	–	–	–	SSI3Fss	EPIOS21
PQ2	H4	–	–	–	T7CCP0	–	–	–	–	–	–	–	–	SSI3XDAT0	EPIOS22
PQ3	M4	–	–	–	T7CCP1	–	–	–	–	–	–	–	–	SSI3XDAT1	EPIOS23
PQ4	A13	–	U1Rx	–	–	–	–	–	DIVSCLK	–	–	–	–	–	–
PQ5	W12	–	U1Tx	–	–	–	–	–	–	–	–	–	–	EN0RXD0	–
PQ6	U15	–	U1DTR	–	–	–	–	–	–	–	–	–	–	EN0RXD1	–
PQ7	M3	–	U1RI	–	–	–	–	–	–	–	–	–	–	–	–
PR0	N5	–	U4Tx	I2C1SCL	–	–	–	M0PWM0	–	–	–	–	–	–	LCDCP
PR1	N4	–	U4Rx	I2C1SDA	–	–	–	M0PWM1	–	–	–	–	–	–	LCDFP
PR2	N2	–	–	I2C2SCL	–	–	–	M0PWM2	–	–	–	–	–	–	LCDLP
PR3	V8	–	–	I2C2SDA	–	–	–	M0PWM3	–	–	–	–	–	–	LCDATA0 3
PR4	P3	–	–	I2C3SCL	T0CCP0	–	–	M0PWM4	–	–	–	–	–	–	LCDATA0 0
PR5	P2	–	U1Rx	I2C3SDA	T0CCP1	–	–	M0PWM5	–	–	–	–	–	–	LCDATA0 1



表 4-4. GPIO Pins and Alternate Functions (continued)

I/O	PIN	ANALOG OR SPECIAL FUNCTION <sup>(1)</sup>	DIGITAL FUNCTION (GPIOCTL PMCx BIT FIELD ENCODING)											
			1	2	3	4	5	6	7	8	11	13	14	15
PR6	W9	–	U1Tx	I2C4SCL	T1CCP0	–	–	M0PWM6	–	–	–	–	–	LCDDATA04
PR7	R10	–	–	I2C4SDA	T1CCP1	–	–	M0PWM7	–	–	–	–	EN0TXEN	LCDDATA05
PS0	D12	–	–	–	T2CCP0	–	–	M0FAULT0	–	–	–	–	–	LCDDATA20
PS1	D13	–	–	–	T2CCP1	–	–	M0FAULT1	–	–	–	–	–	LCDDATA21
PS2	B14	–	U1DSR	–	T3CCP0	–	–	M0FAULT2	–	–	–	–	–	LCDDATA22
PS3	A14	–	–	–	T3CCP1	–	–	M0FAULT3	–	–	–	–	–	LCDDATA23
PS4	V9	–	–	–	T4CCP0	–	–	PhA0	–	–	–	–	EN0TXD0	LCDDATA06
PS5	T13	–	–	–	T4CCP1	–	–	PhB0	–	–	–	–	EN0TXD1	LCDDATA07
PS6	U10	–	–	–	T5CCP0	–	–	IDX0	–	–	–	–	EN0RXER	LCDDATA08
PS7	R13	–	–	–	T5CCP1	–	–	–	–	–	–	–	EN0RXDV	LCDDATA09
PT0	W10	–	–	–	T6CCP0	–	–	–	CAN0Rx	–	–	–	EN0RXD0	LCDDATA10
PT1	V10	–	–	–	T6CCP1	–	–	–	CAN0Tx	–	–	–	EN0RXD1	LCDDATA11
PT2	E18	–	–	–	T7CCP0	–	–	–	CAN1Rx	–	–	–	–	LCDDATA18
PT3	F17	–	–	–	T7CCP1	–	–	–	CAN1Tx	–	–	–	–	LCDDATA19

## 4.5 Buffer Type

表 4-5 describes the buffer types that are referenced in 节 4.2.

表 4-5. Buffer Type

BUFFER TYPE (STANDARD)	NOMINAL VOLTAGE	HYSTERESIS	PU OR PD	NOMINAL PU OR PD STRENGTH ( $\mu$ A)	OUTPUT DRIVE STRENGTH (mA)	OTHER CHARACTERISTICS
Analog <sup>(1)</sup>	3.3 V	N	N/A	N/A	N/A	See analog modules in 节 5 for details.
LVC MOS	3.3 V	Y <sup>(2)</sup>	Programmable	See Input/Output Pin Characteristics	See Typical Characteristics.	
Power (VDD) <sup>(3)</sup>	3.3 V	N	N/A	N/A	N/A	
Power (VDDA) <sup>(3)</sup>	3.3 V	N	N/A	N/A	N/A	
Power (GND and GND A) <sup>(3)</sup>	0 V	N	N/A	N/A	N/A	

(1) This is a switch, not a buffer.

(2) Only for input pins

(3) This is supply input, not a buffer.

## 4.6 Connections for Unused Pins

表 4-6 lists the recommended connections for unused pins.

表 4-6 lists two options: an acceptable practice and a preferred practice for reduced power consumption and improved EMC characteristics. If a module is not used in a system, and its inputs are grounded, it is important that the clock to the module is never enabled by setting the corresponding bit in the RCGCx register.

表 4-6. Connections for Unused Pins

FUNCTION	SIGNAL NAME	PIN NUMBER	ACCEPTABLE PRACTICE	PREFERRED PRACTICE
ADC	VREFA+	F4	VDDA	VDDA
	VREFA-	G5	GND	GND
Ethernet	EN0RXIN	V13	NC	NC
	EN0RXIP	W13	NC	NC
	EN0TXON	V14	NC	NC
	EN0TXOP	V15	NC	NC
	RBIAS	W15	Connect to ground through 4.87-k $\Omega$ resistor.	Connect to ground through 4.87-k $\Omega$ resistor.
GPIO	PA1 (U0Tx)	W3	NC	GND
	PA4 (SSIOXDAT0)	V4	NC	GND
	All unused GPIOs	–	NC	GND
Hibernate	GNDX	R18	GND	GND
	HIB	M17	NC	NC
	VBAT	P19	NC	VDD
	$\overline{\text{WAKE}}$	U18	NC	GND
	XOSC0	T18	NC	GND
	XOSC1	T19	NC	NC
No connects	NC	See NC pin numbers in 表 4-3	NC	NC

**表 4-6. Connections for Unused Pins (continued)**

FUNCTION	SIGNAL NAME	PIN NUMBER	ACCEPTABLE PRACTICE	PREFERRED PRACTICE
System control	GNDX2	D18	GND	GND
	OSC0	E19	NC	GND
	OSC1	D19	NC	NC
	RST	P18	VDD	Pull up to VDD with 0 to 100-kΩ resistor <sup>(1)</sup> .
USB	USB0DM	B18	NC	Pull down to GND with 1-kΩ resistor <sup>(2)</sup> .
	PL7			
	USB0DP	C18	NC	Pull down to GND with 1-kΩ resistor <sup>(2)</sup> .
	PL6			

(1) For details, see the *System Control* chapter of the [SimpleLink™ MSP432E4 Microcontrollers Technical Reference Manual](#)

(2) The ROM bootloader may configure these pins as USB pins if no code is present in the flash; therefore, they should not be directly connected to ground.

## 5 Specifications

### 5.1 Absolute Maximum Ratings

over operating free-air temperature range (unless otherwise noted) <sup>(1)</sup> <sup>(2)</sup>

		MIN	MAX	UNIT
V <sub>DD</sub>	V <sub>DD</sub> supply voltage	0	4	V
V <sub>DDA</sub>	V <sub>DDA</sub> supply voltage	0	4	V
V <sub>BAT</sub>	V <sub>BAT</sub> battery supply voltage	0	4	V
V <sub>BATRMP</sub>	V <sub>BAT</sub> battery supply voltage ramp time	0	0.7	V/μs
V <sub>IN_GPIO</sub>	Input voltage <sup>(3)</sup>	-0.3	4	V
I <sub>GPIO MAX</sub>	Maximum current per output pin		64	mA
T <sub>S</sub>	Unpowered storage temperature range	-65	150	°C
T <sub>JMAX</sub>	Maximum junction temperature		125	°C

- (1) Stresses beyond those listed under *Absolute Maximum Ratings* may cause permanent damage to the device. These are stress ratings only, and functional operation of the device at these or any other conditions beyond those indicated under *Recommended Operating Conditions* is not implied. Exposure to absolute-maximum-rated conditions for extended periods may affect device reliability.
- (2) Voltages are measured with respect to GND.
- (3) Applies to static and dynamic signals including overshoot.

### 5.2 ESD Ratings

over operating free-air temperature range (unless otherwise noted)

		VALUE	UNIT
V <sub>(ESD)</sub>	Electrostatic discharge	Human-body model (HBM), per ANSI/ESDA/JEDEC JS-001 <sup>(1)</sup> <sup>(2)</sup>	±2000
		Charged-device model (CDM), per JEDEC specification JESD22-C101 <sup>(3)</sup>	±500

- (1) JEDEC document JEP155 states that 500-V HBM allows safe manufacturing with a standard ESD control process. Pins listed as ±2000 V may actually have higher performance.
- (2) All pins are HBM compliant to ±2000 V for all combinations as per JESD22-A114F, except for the following stress combinations:
- The Ethernet EN0RXIN, EN0TXON, EN0RXIP, and EN0TXOP pins to each other.
  - The GPIO pins PM4, PM5, PM6, and PM7 to other pins.
- These exceptions are compliant to 500 V and do not require any special handling beyond typical ESD control procedures during assembly operations per JEDEC publication JEP155. These pins do meet the 500-V CDM specification.
- (3) JEDEC document JEP157 states that 250-V CDM allows safe manufacturing with a standard ESD control process. Pins listed as ±500 V may actually have higher performance.

### 5.3 Recommended Operating Conditions

over operating free-air temperature range (unless otherwise noted)

		MIN	MAX	UNIT	
T <sub>A</sub>	Ambient operating temperature range	Extended temperature	-40	105	°C
T <sub>J</sub>	Junction operating temperature range	Extended temperature	-40	125	°C

### 5.4 Recommended DC Operating Conditions

over operating free-air temperature (unless otherwise noted)

		MIN	NOM	MAX	UNIT
V <sub>DD</sub>	V <sub>DD</sub> supply voltage	2.97	3.3	3.63	V
V <sub>DDA</sub>	V <sub>DDA</sub> supply voltage <sup>(1)</sup>	2.97	3.3	3.63	V
V <sub>DDC</sub>	V <sub>DDC</sub> supply voltage, run mode	1.14	1.2	1.32	V
V <sub>DDCDS</sub>	V <sub>DDC</sub> supply voltage, deep-sleep mode	0.85		0.95	V

- (1) To ensure proper operation, power on V<sub>DDA</sub> before V<sub>DD</sub> if sourced from different supplies, or connect V<sub>DDA</sub> to the same supply as V<sub>DD</sub>. No restriction exists for powering off.

### 5.5 Recommended GPIO Operating Characteristics

The following sections describe the recommended GPIO operating characteristics for the device.

Two types of pads are provided on the device:

- Fast GPIO pads: These pads provide variable, programmable drive strength and optimized voltage output levels.
- Slow GPIO pads: These pads provide 2-mA drive strength and are designed to be sensitive to voltage inputs. The PJ1 GPIOs port pins are slow GPIO pads. All other GPIOs have a fast GPIO pad type.

注

Port pins PL6 and PL7 operate as fast GPIO pads, but have 4-mA drive capability only. GPIO register controls for drive strength, slew rate and open drain have no effect on these pins. The registers which have no effect are as follows: GPIODR2R, GPIODR4R, GPIODR8R, GPIODR12R, GPIOCLR, and GPIOODR.

注

Port pins PM[7:4] operate as fast GPIO pads but support only 2-, 4-, 6-, and 8-mA drive capability. 10- and 12-mA drive are not supported. All standard GPIO register controls, except for the GPIODR12R register, apply to these port pins.

## 5.6 Recommended Fast GPIO Pad Operating Conditions

over operating free-air temperature range (unless otherwise noted)

		MIN	NOM	MAX	UNIT
$V_{IH}$	Fast GPIO high-level input voltage	$0.65 \times V_{DD}$		4	V
$I_{IH}$	Fast GPIO high-level input current			300	nA
$V_{IL}$	Fast GPIO low-level input voltage	0		$0.35 \times V_{DD}$	V
$I_{IL}$	Fast GPIO low-level input current <sup>(1)</sup>			-200	nA
$V_{HYS}$	Fast GPIO input hysteresis	0.49			V
$V_{OH}$	Fast GPIO high-level output voltage	2.4			V
$V_{OL}$	Fast GPIO low-level output voltage			0.40	V
$I_{OH}$	Fast GPIO high-level source current, $V_{OH} = 2.4$ V <sup>(2)</sup>	2-mA drive		2.0	mA
		4-mA drive		4.0	
		8-mA drive		8.0	
		10-mA drive		10.0	
		12-mA drive		12.0	
$I_{OL}$	Fast GPIO low-level sink current, $V_{OL} = 0.4$ V <sup>(2)</sup>	2-mA drive		2.0	mA
		4-mA drive		4.0	
		8-mA drive		8.0	
		10-mA drive		10.0	
		12-mA drive		12.0	
		12-mA drive overdriven to 18 mA		18.0	

(1) Output, pullup, and pulldown are disabled; only input is enabled.

(2)  $I_O$  specifications reflect the maximum current where the corresponding output voltage meets the  $V_{OH}$  or  $V_{OL}$  thresholds.  $I_O$  current can exceed these limits (subject to absolute maximum ratings).

## 5.7 Recommended Slow GPIO Pad Operating Conditions

over operating free-air temperature range (unless otherwise noted)

		MIN	NOM	MAX	UNIT
$V_{IH}$	Slow GPIO high-level input voltage	$0.65 \times V_{DD}$		4	V
$I_{IH}$	Slow GPIO high-level input current			4.1	nA

## Recommended Slow GPIO Pad Operating Conditions (continued)

over operating free-air temperature range (unless otherwise noted)

		MIN	NOM	MAX	UNIT
$V_{IL}$	Slow GPIO low-level input voltage	0		$0.35 \times V_{DD}$	V
$I_{IL}$	Slow GPIO low-level input current <sup>(1)</sup>			-1	nA
$V_{HYS}$	Slow GPIO input hysteresis	0.49			V
$V_{OH}$	Slow GPIO high-level output voltage	2.4			V
$V_{OL}$	Slow GPIO low-level output voltage			0.4	V
$I_{OH}$	Slow GPIO high-level source current, $V_{OH} = 2.4$ V, 2-mA drive	2.0			mA
$I_{OL}$	Slow GPIO low-level sink current, $V_{OL} = 0.4$ V <sup>(2)</sup> , 2-mA drive	2.0			mA

(1) Output, pullup, and pulldown are disabled; only input is enabled.

(2)  $I_O$  specifications reflect the maximum current where the corresponding output voltage meets the  $V_{OH}$  or  $V_{OL}$  thresholds.  $I_O$  current can exceed these limits (subject to absolute maximum ratings).

## 5.8 GPIO Current Restrictions

over operating free-air temperature range (unless otherwise noted) <sup>(1)</sup>

		MIN	NOM	MAX	UNIT
$I_{MAXL}$	Cumulative maximum GPIO current per side, left			110	mA
$I_{MAXB}$	Cumulative maximum GPIO current per side, bottom <sup>(2)</sup>			116	mA
$I_{MAXR}$	Cumulative maximum GPIO current per side, right <sup>(2)</sup>			110	mA
$I_{MAXT}$	Cumulative maximum GPIO current per side, top <sup>(2)</sup>			88	mA

(1) Based on design simulations, not tested in production.

(2) Sum of sink and source current for GPIOs as listed in 表 5-1.

表 5-1. Maximum GPIO Package Side Assignments

SIDE	GPIOs
Left	PB[6-7], PC[4-7], PD[0-3], PE[0-3], PH[0-7], PJ[6-7], PK[0-3], PQ[0-3,7], PR[0-5]
Bottom	PA[0-7], PF[0-7], PG[0-7], PK[4-7], PN[6-7], PR[3,6-7], PQ[5-6], PS[4-7], PT[0-1]
Right	PB[0-3], PJ[2-5], PL[0-5,6-7], PM[0-7], PT[2-3]
Top	PB[4-5], PC[0-3], PD[4-7], PE[4-7], PJ[0-1], PN[0-5], PP[0-7], PQ[4], PS[0-3]

## 5.9 I/O Reliability

For typical continuous drive applications, I/O pins configured in the range from 2 mA to 12 mA and operating at  $-40^{\circ}\text{C}$  to  $85^{\circ}\text{C}$  meet the standard 10-year lifetime reliability. If a continuous current sink of 18 mA is required, then operation is limited to 0 to  $75^{\circ}\text{C}$  to meet the standard 10-year reliability.

At  $105^{\circ}\text{C}$ , I/O pins configured for continuous drive meet the standard 2.5-year lifetime reliability.

In typical switching applications (40% switch rate) operating at  $-40^{\circ}\text{C}$  to  $85^{\circ}\text{C}$ , all I/O configurations except 2 mA meet the standard 10-year lifetime reliability with 50-pF loading. By limiting the capacitive loading to 20 pF for an I/O configured to 2 mA, the 10-year lifetime reliability can be met at  $-40^{\circ}\text{C}$  to  $85^{\circ}\text{C}$ .

In typical switching applications (40% switch rate) operating at  $105^{\circ}\text{C}$ , all I/O configurations except 2 mA meet the standard 2.5-year lifetime reliability. By reducing the capacitive loading to 20 pF with a typical switching rate at  $105^{\circ}\text{C}$ , a 2-mA I/O configuration meets a 2.5-year lifetime reliability.

## 5.10 Current Consumption

 over operating free-air temperature (unless otherwise noted) <sup>(1)</sup>

PARAMETER	TEST CONDITIONS	SYSTEM CLOCK		TYP				MAX		UNIT	
		FREQ	CLOCK SOURCE	-40°C	25°C	85°C	105°C	85°C	105°C <sup>(2)</sup>		
$I_{DD\_RUN}$	Run mode (flash loop)	$V_{DD} = 3.3\text{ V}$ , $V_{DDA} = 3.3\text{ V}$ , Peripherals = All on including MAC and PHY	120 MHz	MOSC with PLL	96.4	105.3	107.2	108.7	129.9	140.0	mA
			60 MHz	MOSC with PLL	67.4	76.6	78.6	79.9	100.3	112.5	
			16 MHz	PIOSC	11.9	24.4	25.5	26.7	45.0	56.4	
			1 MHz	PIOSC	5.75	10.9	12.1	13.3	31.3	42.6	
		$V_{DD} = 3.3\text{ V}$ , $V_{DDA} = 3.3\text{ V}$ , Peripherals = All on including MAC but not PHY	120 MHz	MOSC with PLL	69.9	77.8	79.6	80.8	98.8	108.4	
			60 MHz	MOSC with PLL	40.9	49.2	50.9	52.1	69.2	80.8	
			16 MHz	PIOSC	11.3	23.6	25.0	26.2	43.1	54.3	
			1 MHz	PIOSC	5.10	10.1	11.5	12.7	29.3	40.5	
		$V_{DD} = 3.3\text{ V}$ , $V_{DDA} = 3.3\text{ V}$ , Peripherals = All on except MAC and PHY	120 MHz	MOSC with PLL	68.1	76.0	77.6	78.6	96.6	106.0	
			60 MHz	MOSC with PLL	40.0	48.2	49.8	50.8	67.9	79.2	
			16 MHz	PIOSC	11.1	23.3	24.6	25.6	42.5	53.3	
			1 MHz	PIOSC	5.07	10.1	11.3	12.3	29.0	39.8	
	$V_{DD} = 3.3\text{ V}$ , $V_{DDA} = 3.3\text{ V}$ , Peripherals = All off	120 MHz	MOSC with PLL	35.2	39.1	40.4	41.5	55.8	65.3		
		60 MHz	MOSC with PLL	23.2	29.4	30.7	31.7	45.8	55.5		
		16 MHz	PIOSC	7.38	17.9	19.0	20.0	34.5	44.1		
		1 MHz	PIOSC	4.12	9.13	10.3	11.4	25.7	35.5		
	Run mode (SRAM loop)	$V_{DD} = 3.3\text{ V}$ , $V_{DDA} = 3.3\text{ V}$ , Peripherals = All on including MAC and PHY	120 MHz	MOSC with PLL	93.8	103.6	111.6	113.2	133.4	144.6	
			60 MHz	MOSC with PLL	66.9	76.7	78.7	80.0	100.0	111.9	
			16 MHz	PIOSC	12.6	19.0	20.1	21.3	39.1	50.3	
			1 MHz	PIOSC	5.73	10.6	11.7	12.8	30.9	42.2	
		$V_{DD} = 3.3\text{ V}$ , $V_{DDA} = 3.3\text{ V}$ , Peripherals = All on including MAC but not PHY	120 MHz	MOSC with PLL	67.2	76.1	84.0	85.4	102.3	113.0	
			60 MHz	MOSC with PLL	40.3	49.2	50.9	52.2	68.9	80.2	
			16 MHz	PIOSC	11.9	18.2	19.6	20.8	37.2	48.2	
			1 MHz	PIOSC	5.08	9.79	11.2	12.3	28.9	40.1	
$V_{DD} = 3.3\text{ V}$ , $V_{DDA} = 3.3\text{ V}$ , Peripherals = All on except MAC and PHY		120 MHz	MOSC with PLL	65.4	74.3	82.0	83.2	100.1	110.6		
		60 MHz	MOSC with PLL	39.4	48.2	49.8	50.9	67.6	78.6		
		16 MHz	PIOSC	11.7	17.9	19.2	20.2	36.6	47.2		
		1 MHz	PIOSC	5.05	9.75	11.0	11.9	28.6	39.4		
$V_{DD} = 3.3\text{ V}$ , $V_{DDA} = 3.3\text{ V}$ , Peripherals = All off	120 MHz	MOSC with PLL	35.4	43.3	44.7	45.8	59.8	69.0			
	60 MHz	MOSC with PLL	23.4	29.4	30.7	31.7	45.5	54.9			
	16 MHz	PIOSC	7.08	12.4	13.6	14.6	28.7	38.0			
	1 MHz	PIOSC	4.60	8.78	10.0	11.0	25.3	34.9			

(1) Section 5.11 lists the current consumption that specific peripherals contribute to the run mode current consumption in Section 5.10. If these peripherals are not powered, then the peripheral current consumption can be subtracted from the run mode consumption in Section 5.10.

(2) Applicable to extended temperature devices only.

## Current Consumption (continued)

over operating free-air temperature (unless otherwise noted) <sup>(1)</sup>

PARAMETER	TEST CONDITIONS	SYSTEM CLOCK		TYP				MAX		UNIT	
		FREQ	CLOCK SOURCE	-40°C	25°C	85°C	105°C	85°C	105°C <sup>(2)</sup>		
$I_{DD\_SLEEP}$	Sleep mode (FLASHPM = 0x0)	$V_{DD} = 3.3\text{ V}$ , $V_{DDA} = 3.3\text{ V}$ , Peripherals = All on including MAC and PHY, LDO = 1.2 V	120 MHz	MOSC with PLL	82.8	94.8	96.8	98.1	117.9	129.1	mA
			60 MHz	MOSC with PLL	60.8	69.2	71.2	72.3	91.8	102.9	
			16 MHz	PIOSC	11.2	16.8	18.1	19.1	35.4	45.9	
			1 MHz	PIOSC <sup>(3)</sup>	5.10	10.3	11.5	12.6	28.9	39.6	
		$V_{DD} = 3.3\text{ V}$ , $V_{DDA} = 3.3\text{ V}$ , Peripherals = All on including MAC but not PHY, LDO = 1.2 V	120 MHz	MOSC with PLL	56.2	67.4	69.1	70.3	87.1	97.8	
			60 MHz	MOSC with PLL	34.4	41.9	43.4	44.5	60.7	71.6	
			16 MHz	PIOSC <sup>(3)</sup>	10.6	16.2	17.5	18.5	34.5	45.1	
			1 MHz	PIOSC <sup>(3)</sup>	4.47	9.60	10.9	12.0	28.0	38.7	
		$V_{DD} = 3.3\text{ V}$ , $V_{DDA} = 3.3\text{ V}$ , Peripherals = All on except MAC and PHY, LDO = 1.2 V	120 MHz	MOSC with PLL	54.4	65.6	67.1	68.1	84.9	95.4	
			60 MHz	MOSC with PLL	33.5	40.9	42.3	43.2	59.4	70.0	
			16 MHz	PIOSC <sup>(3)</sup>	10.4	15.9	17.1	17.9	33.9	44.1	
			1 MHz	PIOSC <sup>(3)</sup>	4.44	9.56	10.7	11.6	27.7	38.0	
	$V_{DD} = 3.3\text{ V}$ , $V_{DDA} = 3.3\text{ V}$ , Peripherals = All off, LDO = 1.2 V	120 MHz	MOSC with PLL	22.0	28.6	29.8	30.7	44.1	53.1		
		60 MHz	MOSC with PLL	16.3	22.0	23.2	24.1	37.5	46.6		
		16 MHz	PIOSC <sup>(3)</sup>	5.37	10.4	11.5	12.4	26.1	35.1		
		1 MHz	PIOSC <sup>(3)</sup>	4.37	8.60	9.71	10.6	24.6	33.9		
	Sleep mode (FLASHPM = 0x2)	$V_{DD} = 3.3\text{ V}$ , $V_{DDA} = 3.3\text{ V}$ , Peripherals = All on including MAC and PHY, LDO = 1.2 V	120 MHz	MOSC with PLL	86.5	89.0	91.2	92.5	112.1	123.5	
			60 MHz	MOSC with PLL	61.6	63.4	65.6	66.7	86.0	97.2	
			16 MHz	PIOSC <sup>(3)</sup>	10.4	11.1	12.4	13.5	29.8	40.4	
			1 MHz	PIOSC <sup>(3)</sup>	4.45	4.49	5.83	6.98	23.4	34.2	
		$V_{DD} = 3.3\text{ V}$ , $V_{DDA} = 3.3\text{ V}$ , Peripherals = All on including MAC but not PHY, LDO = 1.2 V	120 MHz	MOSC with PLL	59.9	61.7	63.4	64.7	81.3	92.1	
			60 MHz	MOSC with PLL	35.1	36.1	37.8	38.9	54.9	66.0	
			16 MHz	PIOSC <sup>(3)</sup>	9.75	10.4	11.8	12.9	28.9	39.6	
			1 MHz	PIOSC <sup>(3)</sup>	3.82	3.82	5.25	6.38	22.5	33.4	
		$V_{DD} = 3.3\text{ V}$ , $V_{DDA} = 3.3\text{ V}$ , Peripherals = All on except MAC and PHY, LDO = 1.2 V	120 MHz	MOSC with PLL	58.1	59.9	61.4	62.5	79.1	89.7	
			60 MHz	MOSC with PLL	34.2	35.1	36.7	37.6	53.6	64.4	
			16 MHz	PIOSC <sup>(3)</sup>	9.50	10.1	11.4	12.3	28.3	38.6	
			1 MHz	PIOSC <sup>(3)</sup>	3.79	3.78	5.06	5.96	22.2	32.7	
$V_{DD} = 3.3\text{ V}$ , $V_{DDA} = 3.3\text{ V}$ , Peripherals = All off, LDO = 1.2 V		120 MHz	MOSC with PLL	22.0	22.8	24.1	25.1	38.2	47.4		
		60 MHz	MOSC with PLL	15.7	16.2	17.5	18.5	31.7	40.9		
		16 MHz	PIOSC <sup>(3)</sup>	4.50	4.60	5.80	6.80	20.5	29.8		
		1 MHz	PIOSC <sup>(3)</sup>	3.00	2.80	4.10	5.20	19.1	28.7		

(3) If the MOSC is the source of the run-mode system clock and is powered down in sleep mode, wake time is increased by  $t_{MOSC\_SETTLE}$ .



## Current Consumption (continued)

over operating free-air temperature (unless otherwise noted) <sup>(1)</sup>

PARAMETER	TEST CONDITIONS	SYSTEM CLOCK		TYP				MAX		UNIT	
		FREQ	CLOCK SOURCE	-40°C	25°C	85°C	105°C	85°C	105°C <sup>(2)</sup>		
$I_{DD\_DEEPSLEEP}$	Deep-sleep mode (FLASHPM = 0x2)	$V_{DD} = 3.3\text{ V}$ , $V_{DDA} = 3.3\text{ V}$ , Peripherals = All on, LDO = 1.2 V	16 MHz	PIOSC	9.74	9.78	10.8	11.6	24.1	32.1	mA
			30 kHz	LFIOOSC	2.60	2.83	3.83	4.60	17.1	25.3	
		$V_{DD} = 3.3\text{ V}$ , $V_{DDA} = 3.3\text{ V}$ , Peripherals = All off, LDO = 1.2 V	16 MHz	PIOSC	4.53	4.05	4.88	5.53	15.9	22.7	
			30 kHz	LFIOOSC	0.614	0.762	1.69	2.46	13.3	20.7	
		$V_{DD} = 3.3\text{ V}$ , $V_{DDA} = 3.3\text{ V}$ , Peripherals = All on, LDO = 0.9 V	16 MHz	PIOSC	5.21	7.33	7.97	8.48	15.3	20.1	
			30 kHz	LFIOOSC	2.02	2.16	2.79	3.29	10.0	14.9	
$I_{DDA\_RUN}$ , $I_{DDA\_SLEEP}$	All run modes	$V_{DD} = 3.3\text{ V}$ , $V_{DDA} = 3.3\text{ V}$ , Peripherals = All on	120 MHz	MOSC with PLL	2.61	2.66	2.68	2.66	3.03	3.35	mA
			60 MHz	MOSC with PLL	2.61	2.66	2.68	2.66	3.04	3.10	
			16 MHz	PIOSC	2.45	2.49	2.50	2.48	2.85	2.95	
			1 MHz	PIOSC	2.45	2.48	2.50	2.48	2.84	2.90	
	All sleep modes	$V_{DD} = 3.3\text{ V}$ , $V_{DDA} = 3.3\text{ V}$ , Peripherals = All off	120 MHz	MOSC with PLL	0.227	0.229	0.270	0.250	0.559	0.650	
			60 MHz	MOSC with PLL	0.229	0.232	0.267	0.250	0.579	0.600	
			16 MHz	PIOSC	0.228	0.229	0.265	0.251	0.545	0.575	
			1 MHz	PIOSC	0.227	0.227	0.267	0.247	0.549	0.555	
$I_{DDA\_DEEPSLEEP}$	Deep-sleep mode (FLASHPM = 0x2)	$V_{DD} = 3.3\text{ V}$ , $V_{DDA} = 3.3\text{ V}$ , Peripherals = All on, LDO = 1.2 V	16 MHz	PIOSC	2.45	2.48	2.50	2.48	2.84	2.90	mA
			30 kHz	LFIOOSC	2.45	2.48	2.50	2.48	2.85	2.90	
		$V_{DD} = 3.3\text{ V}$ , $V_{DDA} = 3.3\text{ V}$ , Peripherals = All off, LDO = 1.2 V	16 MHz	PIOSC	0.226	0.227	0.265	0.249	0.558	0.635	
			30 kHz	LFIOOSC	0.228	0.227	0.272	0.247	0.558	0.600	
		$V_{DD} = 3.3\text{ V}$ , $V_{DDA} = 3.3\text{ V}$ , Peripherals = All on, LDO = 0.9 V <sup>(4)</sup>	16 MHz	PIOSC	2.14	2.42	2.44	2.42	2.78	2.88	
			30 kHz	LFIOOSC	2.44	2.42	2.44	2.42	2.86	2.88	
		$V_{DD} = 3.3\text{ V}$ , $V_{DDA} = 3.3\text{ V}$ , Peripherals = All off, LDO = 0.9 V <sup>(4)</sup>	16 MHz	PIOSC	0.216	0.166	0.209	0.193	0.563	0.580	
			30 kHz	LFIOOSC	0.223	0.167	0.209	0.189	0.508	0.580	
$I_{HIB\_NORTC}$	Hibernate mode (external wake, RTC disabled)	$V_{BAT} = 3.0\text{ V}$ , $V_{DD} = 0\text{ V}$ , $V_{DDA} = 0\text{ V}$ , System clock = OFF, Hibernate module = 32.768 kHz			1.04	1.20	1.44	1.69	1.62	2.14	$\mu\text{A}$
$I_{HIB\_RTC}$	Hibernate mode (RTC enabled)	$V_{BAT} = 3.0\text{ V}$ , $V_{DD} = 0\text{ V}$ , $V_{DDA} = 0\text{ V}$ , System clock = OFF, Hibernate module = 32.768 kHz			1.12	1.29	1.54	1.82	1.75	2.33	$\mu\text{A}$

(4) See the *System Control* chapter of the [MSP432E4 SimpleLink™ Microcontrollers Technical Reference Manual](#) for information on lowering the LDO voltage to 0.9 V.

## Current Consumption (continued)

over operating free-air temperature (unless otherwise noted) <sup>(1)</sup>

PARAMETER		TEST CONDITIONS	SYSTEM CLOCK		TYP				MAX		UNIT
			FREQ	CLOCK SOURCE	-40°C	25°C	85°C	105°C	85°C	105°C <sup>(2)</sup>	
I <sub>HIB_VDD3ON</sub>	Hibernate mode (VDD3ON mode, tamper enabled)	V <sub>BAT</sub> = 3.0 V, V <sub>DD</sub> = 3.3 V, V <sub>DDA</sub> = 3.3 V, System clock = OFF, Hibernate module = 32.768 kHz			6.78	7.99	17.0	22.1	31.0	46.2	μA
	Hibernate mode (VDD3ON mode, tamper disabled)	V <sub>BAT</sub> = 3.0 V, V <sub>DD</sub> = 3.3 V, V <sub>DDA</sub> = 3.3 V, System clock = OFF, Hibernate module = 32.768 kHz			5.42	6.39	15.4	17.8	28.9	32.0	

## 5.11 Peripheral Current Consumption

over operating free-air temperature (unless otherwise noted)

PARAMETER		TEST CONDITIONS	SYSTEM CLOCK	TYP	UNIT
I <sub>DDUSB</sub>	USB (including USB PHY) run mode current	V <sub>DD</sub> = 3.3 V, V <sub>DDA</sub> = 3.3 V	120 MHz (MOSC with PLL)	4.0	mA
I <sub>DDMAC</sub>	Ethernet MAC run mode current	V <sub>DD</sub> = 3.3 V, V <sub>DDA</sub> = 3.3 V	120 MHz (MOSC with PLL)	1.9	mA
I <sub>DDMACPHY</sub>	Ethernet MAC and PHY run mode current	V <sub>DD</sub> = 3.3 V, V <sub>DDA</sub> = 3.3 V	120 MHz (MOSC with PLL)	30	mA

## 5.12 LDO Regulator Characteristics

over operating free-air temperature (unless otherwise noted)

PARAMETER		MIN	TYP	MAX	UNIT
C <sub>LDO</sub>	External filter capacitor size for internal power supply <sup>(1)</sup>	2.5		4.0	μF
ESR	Filter capacitor equivalent series resistance	0		100	mΩ
ESL	Filter capacitor equivalent series inductance			0.5	nH
V <sub>LDO</sub>	LDO output voltage, run mode	1.13	1.2	1.27	V
I <sub>INRUSH</sub>	Inrush current	50		250	mA

(1) Connect the capacitor as close as possible to pin E10.

### 5.13 Power Dissipation

over operating free-air temperature (unless otherwise noted) <sup>(1)</sup> <sup>(2)</sup>

PARAMETER		T <sub>A</sub>	T <sub>J</sub>	MIN	MAX	UNIT
P <sub>DE</sub>	Extended temperature device power dissipation	105°C (extended temperature part)	125°C (extended temperature part)		509	mW

- (1) If the device exceeds the power dissipation value shown, then modifications such as heat sinks or fans must be used to conform to the limits shown.
- (2) A larger power dissipation allowance can be achieved by lowering T<sub>A</sub> as long as T<sub>JMAX</sub> shown in [Section 5.1](#) is not exceeded.

### 5.14 Thermal Resistance Characteristics, 212-Pin ZAD (NFBGA) Package

over operating free-air temperature range (unless otherwise noted)

THERMAL METRIC		VALUE	UNIT
θ <sub>JA</sub>	Thermal resistance (junction to ambient) <sup>(1)</sup>	39.3	°C/W
θ <sub>JB</sub>	Thermal resistance (junction to board) <sup>(1)</sup>	18.6	°C/W
θ <sub>JC</sub>	Thermal resistance (junction to case) <sup>(1)</sup>	12.9	°C/W
Ψ <sub>JT</sub>	Thermal metric (junction to top of package)	0.2	°C/W
Ψ <sub>JB</sub>	Thermal metric (junction to board)	18.4	°C/W
T <sub>J</sub>	Junction temperature formula	$T_C + (P \times \Psi_{JT})$ <sup>(2)</sup> $T_{PCB} + (P \times \Psi_{JB})$ <sup>(3)</sup> $T_A + (P \times \theta_{JA})$ <sup>(4)</sup> $T_B + (P \times \theta_{JB})$ <sup>(5) (6)</sup>	°C

- (1) Junction to ambient thermal resistance (θ<sub>JA</sub>), junction to board thermal resistance (θ<sub>JB</sub>), and junction to case thermal resistance (θ<sub>JC</sub>) numbers are determined by a package simulator.
- (2) T<sub>C</sub> is the case temperature and P is the device power consumption.
- (3) T<sub>PCB</sub> is the temperature of the board acquired by following the steps listed in the EAI/JESD 51-8 standard summarized in [Semiconductor and IC Package Thermal Metrics](#). P is the device power consumption.
- (4) Because θ<sub>JA</sub> is highly variable and based on factors such as board design, chip size, pad size, altitude, and external ambient temperature, TI recommends using the equations that contain Ψ<sub>JT</sub> and Ψ<sub>JB</sub> for best results.
- (5) T<sub>B</sub> is temperature of the board.
- (6) θ<sub>JB</sub> is not a pure reflection of the internal resistance of the package because it includes the resistance of the testing board and environment. TI recommends using equations that contain Ψ<sub>JT</sub> and Ψ<sub>JB</sub> for best results.

## 5.15 Timing and Switching Characteristics

### 5.15.1 Load Conditions

表 5-2 shows the load conditions used for timing measurements, and 表 5-2 lists the load values for the specified signals.



图 5-1. Load Conditions

表 5-2. Load Conditions

SIGNALS	LOAD VALUE (C <sub>L</sub> )
LCDDATA[23:0]	25 pF
EPIOS[35:0] SDRAM interface	30 pF
EPIOS[35:0] general-purpose interface	
EPIOS[35:0] host-bus interface	
EPIOS[35:0] PSRAM interface	40 pF
All other digital I/O signals	50 pF

### 5.15.2 Power Supply Sequencing

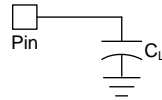
To ensure proper operation, power on  $V_{DDA}$  before  $V_{DD}$  if sourced from different supplies, or connect  $V_{DDA}$  to the same supply as  $V_{DD}$ . No restriction exists for powering off.

#### 5.15.2.1 Power and Brownout

表 5-3. Power and Brownout Levels

over operating free-air temperature (unless otherwise noted)

NO.	PARAMETER		MIN	TYP	MAX	UNIT
P1	$t_{VDDA\_RISE}$	Analog supply voltage ( $V_{DDA}$ ) rise time			$\infty$	$\mu$ s
P2	$t_{VDD\_RISE}$	I/O supply voltage ( $V_{DD}$ ) rise time			$\infty$	$\mu$ s
P3	$t_{VDDC\_RISE}$	Core supply voltage ( $V_{DDC}$ ) rise time	10		150	$\mu$ s
P4	$V_{POR}$	Power-on reset threshold (rising edge)	1.98	2.35	2.72	V
		Power-on reset threshold (falling edge)	1.84	2.20	2.56	
		Power-on reset hysteresis	0.06	0.15	0.24	
P5	$V_{DDA\_POK}$	$V_{DDA}$ power-OK threshold (rising edge)	2.67	2.82	2.97	V
P6	$V_{DDA\_BOR0}$	$V_{DDA}$ brownout reset threshold	2.71	2.80	2.89	V
P7	$V_{DD\_POK}$	$V_{DD}$ power-OK threshold (rising edge)	2.65	2.80	2.90	V
		$V_{DD}$ power-OK threshold (falling edge)	2.67	2.76	2.85	
P8	$V_{DD\_BOR0}$	$V_{DD}$ brownout reset threshold	2.77	2.86	2.95	V
P9	$V_{DDC\_POK}$	$V_{DDC}$ power-OK threshold (rising edge)	0.85	0.95	1.10	V
		$V_{DDC}$ power-OK threshold (falling edge)	0.71	0.80	0.85	

### 5.15.2.1.1 $V_{DDA}$ Levels

The  $V_{DDA}$  supply has three monitors:

- Power-on reset (POR)
- Power-OK (POK)
- Brownout reset (BOR)

The POR monitor is used to keep the analog circuitry in reset until the  $V_{DDA}$  supply reaches the correct range for the analog circuitry to begin operating. The POK monitor is used to keep the digital circuitry in reset until the  $V_{DDA}$  power supply is at an acceptable operational level. The digital reset is only released when the Power-On Reset has deasserted and the Power-OK monitor for each supply indicates that power levels are in operational ranges. The BOR monitor is used to generate a reset to the device or assert an interrupt if the  $V_{DDA}$  supply drops below its operational range.

注

$V_{DDA}$  BOR and  $V_{DD}$  BOR events are a combined BOR to the system logic, such that if either BOR event occurs, the following bits are affected:

- The BORRIS bit in the Raw Interrupt Status (RIS) register, System Control offset 0x050
- The BORMIS bit in the Masked Interrupt Status and Clear (MISC) register, System Control offset 0x058. This bit is set only if the BORIM bit in the Interrupt Mask Control (IMC) register has been set.
- The BOR bit in the Reset Cause (RESC) register, System Control offset 0x05C. This bit is set only if either of the BOR events have been configured to initiate a reset.

In addition, the following bits control both BOR events:

- The BORIM bit in the Interrupt Mask Control (IMC) register, System Control offset 0x054
- The  $V_{DDA\_UBOR0}$  and  $V_{DD\_UBOR0}$  bits in the Power-Temperature Cause (PWRTC) register

See the *System Control* chapter of the [MSP432E4 SimpleLink™ Microcontrollers Technical Reference Manual](#) for more information on how to configure these registers.

图 5-2 shows the relationship between  $V_{DDA}$ , POK, POR, and a BOR event.



图 5-2. Power and Brownout Assertions vs  $V_{DDA}$  Levels

### 5.15.2.1.2 $V_{DD}$ Levels

The  $V_{DD}$  supply has two monitors:

- Power-OK (POK)
- Brownout reset (BOR)

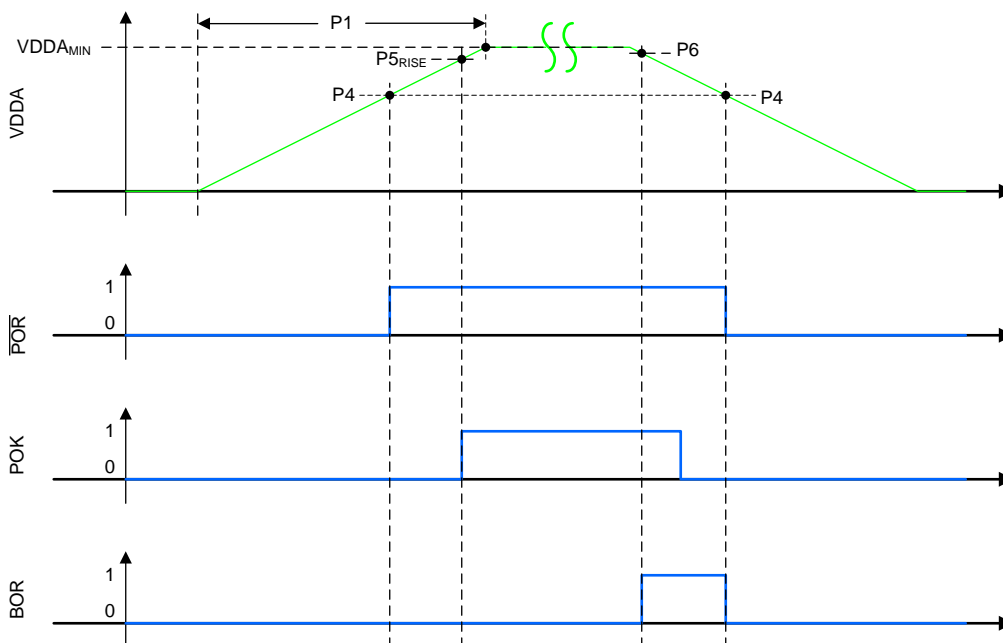
The POK monitor is used to keep the digital circuitry in reset until the  $V_{DD}$  power supply reaches an acceptable operational level. The digital reset is only released when the POR has deasserted and the POK monitor for each supply indicates that power levels are in operational ranges. The BOR monitor is used to generate a reset to the device or assert an interrupt if the  $V_{DD}$  supply drops below its operational range.

注

$V_{DDA}$  BOR and  $V_{DD}$  BOR events are a combined BOR to the system logic, such that if either BOR event occurs, the following bits are affected:

- The BORRIS bit in the Raw Interrupt Status (RIS) register, System Control offset 0x050
- The BORMIS bit in the Masked Interrupt Status and Clear (MISC) register, System Control offset 0x058. This bit is set only if the BORIM bit in the Interrupt Mask Control (IMC) register has been set.
- The BOR bit in the Reset Cause (RESC) register, System Control offset 0x05C. This bit is set only if either of the BOR events have been configured to initiate a reset.

In addition, the following bits control both BOR events:

- The BORIM bit in the Interrupt Mask Control (IMC) register, System Control offset 0x054
- The VDDA\_UBOR0 and VDD\_UBOR0 bits in the Power-Temperature Cause (PWRTC) register

See the *System Control* chapter of the [MSP432E4 SimpleLink™ Microcontrollers Technical Reference Manual](#) for more information on how to configure these registers.

图 5-3 shows the relationship between  $V_{DD}$ , POK, POR, and a BOR event.



图 5-3. Power and Brownout Assertions vs  $V_{DD}$  Levels

### 5.15.2.1.3 V<sub>DCC</sub> Levels

The V<sub>DCC</sub> supply has one monitor, the Power-OK (POK). The POK monitor is used to keep the digital circuitry in reset until the V<sub>DCC</sub> power supply reaches an acceptable operational level. The digital reset is only released when the power-on reset has deasserted and the POK monitor for each supply indicates that power levels are in operational ranges. 图 5-4 shows the relationship between POK and V<sub>DCC</sub>.

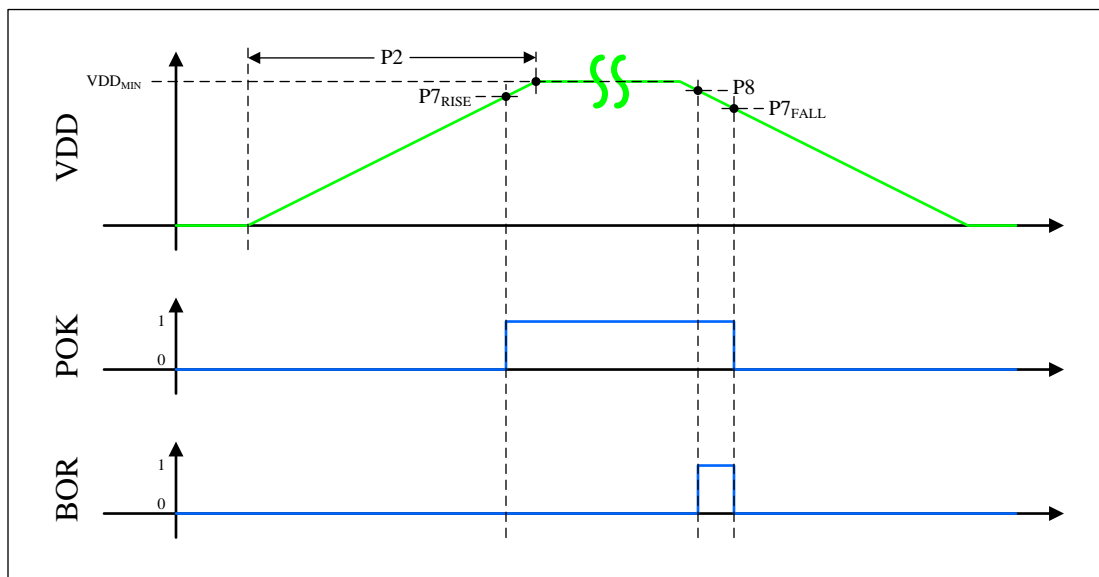

图 5-4. POK Assertion vs V<sub>DCC</sub>

### 5.15.2.1.4 V<sub>DD</sub> Glitch Response

图 5-5 shows the response of the BOR and the POR circuit to glitches on the V<sub>DD</sub> supply.

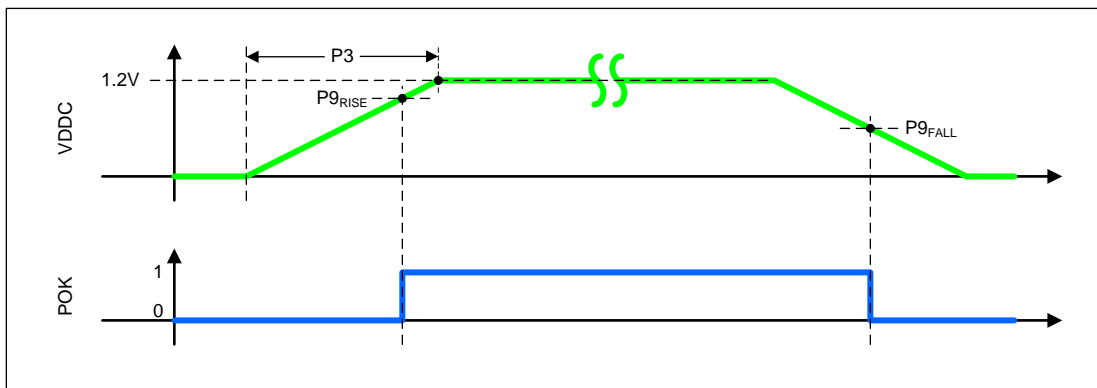

图 5-5. POR-BOR V<sub>DD</sub> Glitch Response

### 5.15.2.1.5 V<sub>DD</sub> Droop Response

图 5-6 shows the response of the BOR and the POR monitors to a drop on the V<sub>DD</sub> supply.

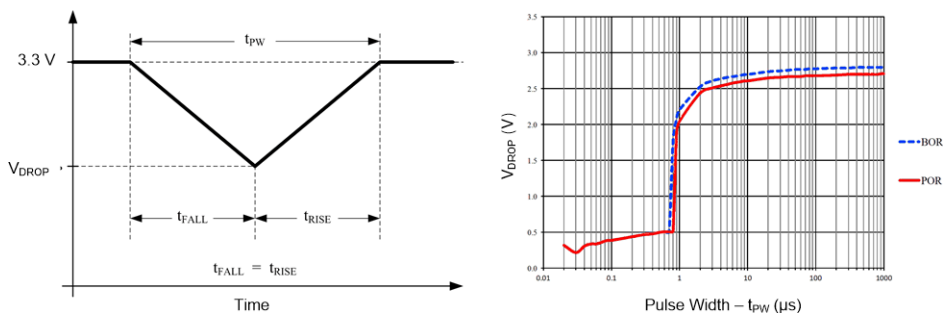

图 5-6. POR-BOR V<sub>DD</sub> Droop Response

## 5.15.3 Reset Timing

表 5-4 lists the reset characteristics.

表 5-4. Reset Characteristics

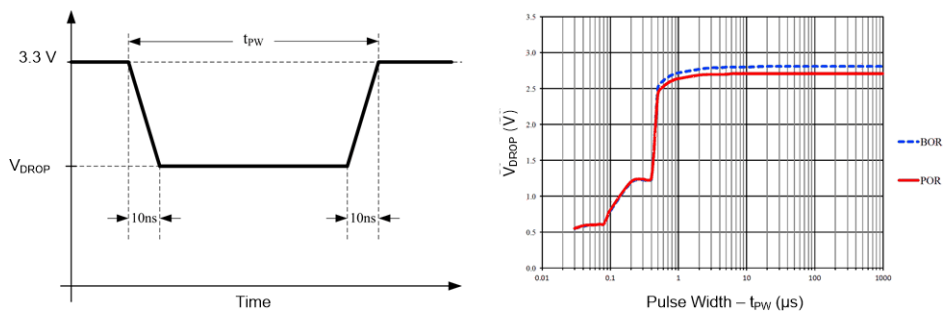
over operating free-air temperature (unless otherwise noted)

NO.	PARAMETER		MIN	TYP	MAX	UNIT
R1	$t_{DPORDLY}$	Digital POR to internal reset assertion delay (see 图 5-7)	0.44		126	$\mu s$
R2	$t_{IRTOU}^{(1)(2)}$	Standard internal reset time		14	16	ms
		Internal reset time with recovery code repair (program or erase) <sup>(3)</sup>	24.4		6400 <sup>(4)</sup>	
R3	$t_{BORODLY}^{(1)}$	BOR0 to internal reset assertion delay <sup>(5)</sup> (see 图 5-8)	0.44		125	$\mu s$
R4	$t_{RSTMIN}$	Minimum $\overline{RST}$ pulse duration		0.25 <sup>(6)</sup> or 100 <sup>(7)</sup>		$\mu s$
R5	$t_{IRHWDLY}$	$\overline{RST}$ to internal reset assertion delay (see 图 5-9)		0.85		$\mu s$
R6	$t_{IRSWR}^{(1)}$	Internal reset time-out after software-initiated system reset (see 图 5-10)		2.44		$\mu s$
R7	$t_{IRWDR}^{(1)}$	Internal reset time-out after watchdog reset (see 图 5-11)		2.44		$\mu s$
R8	$t_{IRMFR}^{(1)}$	Internal reset time-out after MOSC failure reset (see 图 5-12)		2.44		$\mu s$

- (1) These values are based on simulation.
- (2) This is the delay from the time POR is released until the reset vector is fetched.
- (3) This parameter applies only in situations where a power-loss or brownout event occurs during an EEPROM program or erase operation, and EEPROM must be repaired (which is a rare case). For all other sequences, there is no change to normal POR timing. This delay is in addition to other POR delays.
- (4) This value represents the maximum internal reset time when the EEPROM reaches its endurance limit.
- (5) Timing values depend on the  $V_{DD}$  power-down ramp rate.
- (6) Standard operation
- (7) Deep-sleep operation with PIOSC powered down



图 5-7. Digital Power-On Reset Timing

The digital power-on reset is released only when the analog power-on reset has deasserted and the Power-OK monitor for each supply indicates that power levels are in operational ranges.



图 5-8. Brownout Reset Timing

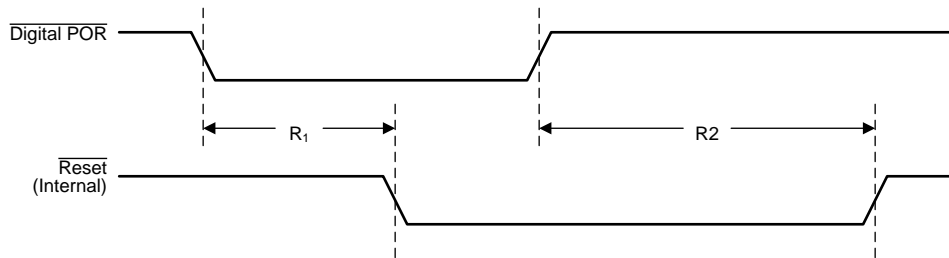



图 5-9. External Reset Timing ( $\overline{\text{RST}}$ )

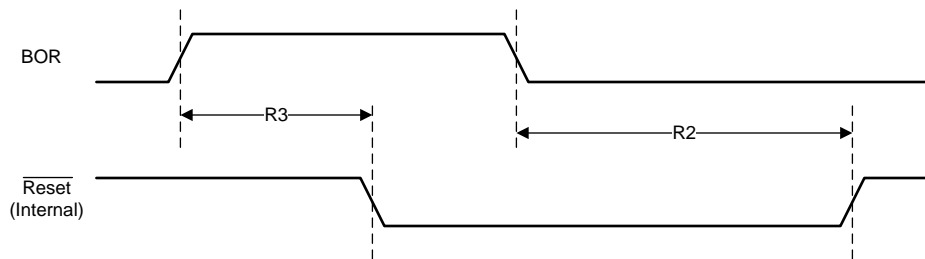

图 5-10. Software Reset Timing

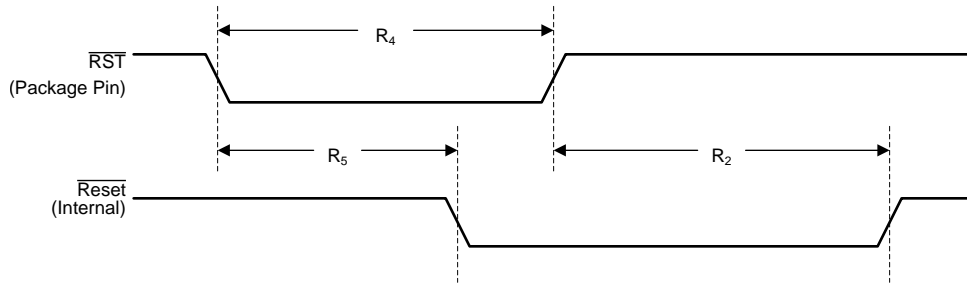

图 5-11. Watchdog Reset Timing

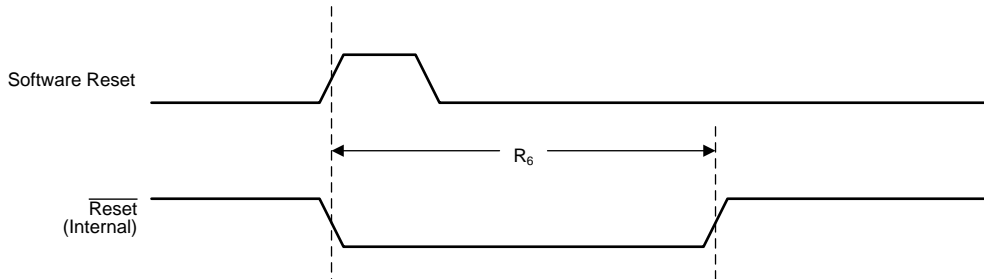

图 5-12. MOSC Failure Reset Timing

### 5.15.4 Clock Specifications

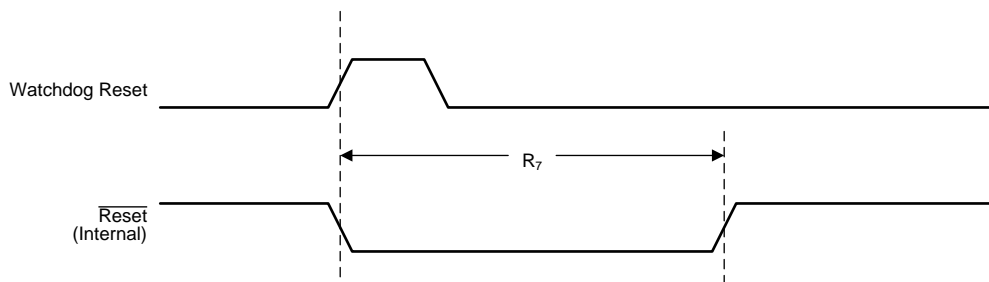
The following sections provide specifications on the various clock sources and mode.

#### 5.15.4.1 PLL Specifications

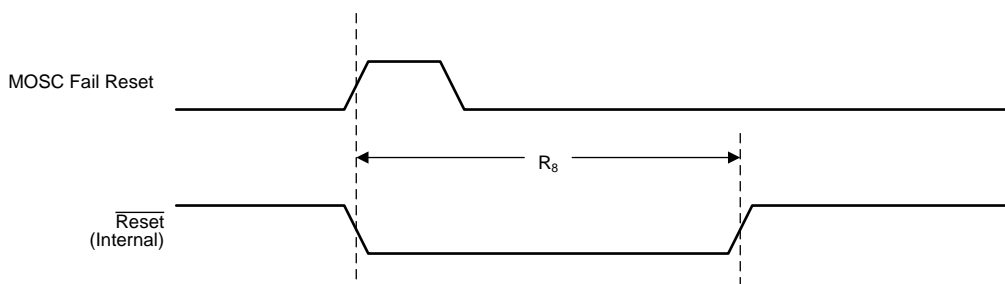
表 5-5 lists the PLL characteristics.

注  
If the integrated Ethernet PHY is used,  $f_{REF\_XTAL}$  and  $f_{REF\_EXT}$  must be 25 MHz.

**表 5-5. Phase Locked Loop (PLL) Characteristics**

over operating free-air temperature (unless otherwise noted)

PARAMETER		MIN	MAX	UNIT
$f_{REF\_XTAL}$	Crystal reference	5	25	MHz
$f_{REF\_EXT}$	External clock reference	5	25	MHz
$f_{PLL}$	PLL VCO frequency at 1.2 V <sup>(1)</sup>	100	480	MHz
$f_{PLLS}$	PLL VCO frequency at 0.9 V <sup>(2)</sup>	100	480	MHz
$t_{READY}$	PLL lock time	Enabling the PLL, when PLL is transitioning from power down to power up	512 × (reference clock period)	μs
		When the PLL VCO frequency is changed (PLL is already enabled)	128 × (reference clock period)	
		Changing the OSCSRC between MOSC and PIOSC	128 × (reference clock period)	

(1) PLL frequency is manually calculated using the values in the PLLFREQ0 and PLLFREQ1 registers.

(2) If the LDO is dropped to 0.9 V, the system must be run 1/4 of the maximum frequency at most. The Q value in the PLLFREQ1 register must be set to 0x3 rather than using the PSYSDIV field in the RSCLKCFG register for the divisor.

##### 5.15.4.1.1 PLL Configuration

The PLL is disabled by default during power-on reset and is enabled later by software if required. Software specifies the output divisor to set the system clock frequency and enables the PLL to drive the output. The PLL is controlled using the PLLFREQ0, PLLFREQ1, and PLLSTAT registers. Changes made to these registers do not become active until after the NEWFREQ bit in the RSCLKCFG register is enabled. The clock source for the main PLL is selected by configuring the PLLSRC field in the Run and Sleep Clock Configuration (RSCLKCFG) register. The PLL allows for the generation of system clock frequencies in excess of the reference clock provided. The reference clocks for the PLL are the PIOSC and the MOSC.

The PLL is controlled by two registers, PLLFREQ0 and PLLFREQ1. The PLL VCO frequency ( $f_{VCO}$ ) is determined through 公式 1.

$$f_{VCO} = f_{IN} \times MDIV$$

where

- $f_{IN} = f_{XTAL} / (Q+1)(N+1)$  or  $f_{PIOSC} / (Q+1)(N+1)$
  - $MDIV = MINT + (MFRAC / 1024)$
- (1)

The Q and N values are programmed in the PLLFREQ1 register. To reduce jitter, program MFRAC to 0x0.

When the PLL is active, the system clock frequency (SysClk) is calculated using 公式 2.

$$SysClk = f_{VCO} / (1 + 1)$$

(2)

The PLL system divisor factor (PSYSDIV) must be set as 1. 表 5-6 lists examples of the system clock frequency.

**表 5-6. Examples of System Clock Frequencies**

$f_{VCO}$ (MHz)	Q	PSYSDIV + 1	System Clock (SYSCLK) Frequency (MHz)
480	2	2	120
480	3	2	80
480	4	2	60
480	5	2	48
320	2	2	80
320	3	2	53
320	4	2	40

If the main oscillator provides the clock reference to the PLL, the translation provided by hardware and used to program the PLL is available for software in the PLL Frequency n (PLLREQn) registers. The internal translation provides a translation within  $\pm 1\%$  of the targeted PLL VCO frequency. 表 5-7 shows the actual PLL frequency and error for a given crystal choice.

表 5-7 provides examples of the programming expected for the PLLREQ0 and PLLREQ1 registers. The CRYSTAL FREQUENCY column specifies the input crystal frequency and the PLL FREQUENCY column displays the PLL frequency given the values of MINT and N, when Q = 0.

**表 5-7. Actual PLL Frequency<sup>(1)</sup>**

CRYSTAL FREQUENCY (MHz)	MINT		N	REFERENCE FREQUENCY (MHz) <sup>(2)</sup>	PLL FREQUENCY (MHz)
	DECIMAL VALUE	HEXADECIMAL VALUE			
5	64	0x40	0x0	5	320
6	160	0x35	0x2	2	320
8	40	0x28	0x0	8	320
10	32	0x20	0x0	10	320
12	80	0x50	0x2	4	320
16	20	0x14	0x0	16	320
18	160	0xA0	0x8	2	320
20	16	0x10	0x0	20	320
24	40	0x28	0x2	8	320
25	64	0x40	0x4	5	320
5	96	0x60	0x0	5	480
6	80	0x50	0x0	6	480
8	60	0x3C	0x0	8	480
10	48	0x30	0x0	10	480
12	40	0x28	0x0	12	480
16	30	0x1E	0x0	16	480
18	80	0x50	0x2	6	480
20	24	0x18	0x0	20	480
24	20	0x14	0x0	24	480
25	96	0x60	0x4	5	480

(1) For all examples listed, Q = 0.

(2) For a given crystal frequency, N should be chosen such that the reference frequency is 4 to 30 MHz.

### 5.15.4.2 PIOSC Specifications

表 5-8 lists the PIOSC characteristics.

表 5-8. PIOSC Clock Characteristics

PARAMETER		MIN	NOM	MAX	UNIT
f <sub>PIOSC</sub>	Factory calibration, 0°C to 105°C: Internal 16-MHz precision oscillator frequency variance across voltage and temperature range when factory calibration is used			±6%	
	Factory calibration, -40°C to <0°C			±10%	
	Recalibration: Internal 16-MHz precision oscillator frequency variance when recalibration is used at a specific temperature			±1%	
t <sub>START</sub>	PIOSC start-up time <sup>(1)</sup>			1	µs

(1) PIOSC start-up time is part of reset and is included in the internal reset time-out value (T<sub>IRTOU</sub>) in 表 5-4. The T<sub>START</sub> value is based on simulation.

### 5.15.4.3 Low-Frequency Oscillator Specifications

表 5-9 lists the characteristics of the low-frequency oscillator.

表 5-9. Low-Frequency Oscillator Characteristics

PARAMETER		MIN	NOM	MAX	UNIT
f <sub>LFIOSC</sub>	Internal low-frequency oscillator frequency	10	33	75	kHz

### 5.15.4.4 Hibernation Low-Frequency Oscillator Specifications

表 5-10. Hibernation External Oscillator (XOSC) Input Characteristics

PARAMETER		MIN	NOM	MAX	UNIT
f <sub>HIBXOSC</sub> <sup>(1)</sup>	Parallel resonance frequency		32.768		kHz
C <sub>1</sub> , C <sub>2</sub>	External load capacitance on XOSC0, XOSC1 pins <sup>(2)</sup>	12		24	pF
C <sub>PKG</sub>	Device package stray shunt capacitance <sup>(2)</sup>		0.5		pF
C <sub>PCB</sub>	PCB stray shunt capacitance <sup>(2)</sup>		0.5		pF
C <sub>SHUNT</sub>	Total shunt capacitance <sup>(2)</sup>			4	pF
ESR	Crystal effective series resistance, OSCDRV = 0 <sup>(3)</sup>			50	kΩ
	Crystal effective series resistance, OSCDRV = 1 <sup>(3)</sup>			75	
DL	Oscillator output drive level			0.25	µW
t <sub>START</sub>	Oscillator start-up time, when using a crystal <sup>(4)</sup>		600	1500 <sup>(5)</sup>	ms
V <sub>IH</sub>	CMOS input high level, when using an external oscillator with V <sub>Supply</sub> > 3.3 V	2.64			V
	CMOS input high level, when using an external oscillator with 1.8 V ≤ V <sub>Supply</sub> ≤ 3.3 V	0.8 × V <sub>Supply</sub>			
V <sub>IL</sub> <sup>(6)</sup>	CMOS input low level, when using an external oscillator with 1.8 V ≤ V <sub>Supply</sub> ≤ 3.63 V			0.2 × V <sub>Supply</sub>	V
V <sub>HYS</sub> <sup>(6)</sup>	CMOS input buffer hysteresis, when using an external oscillator with 1.8 V ≤ V <sub>Supply</sub> ≤ 3.63 V	360	960	1390	mV
DC <sub>HIBOSC_EXT</sub>	External single-ended (bypass) reference duty cycle	30%		70%	

(1) The Hibernation XOSC pins are not fail-safe and must follow the limits in 节 5.15.9.1.2.

(2) See the additional information about the load capacitors following this table.

(3) Crystal ESR specified by crystal manufacturer.

(4) Oscillator start-up time is specified from the time the oscillator is enabled to when it reaches a stable point of oscillation such that the internal clock is valid.

(5) Only valid for recommended supply conditions. Measured with OSCDRV bit set (high drive strength enabled, 24 pF).

(6) Specification is relative to the larger of V<sub>DD</sub> or V<sub>BAT</sub>.

Choose the load capacitors added on the board,  $C_1$  and  $C_2$ , such that 公式 3 is satisfied (see 表 5-10 for typical values).

$$C_L = (C_1 \times C_2) / (C_1 + C_2) + C_{SHUNT}$$

where

- $C_L$  = load capacitance specified by crystal manufacturer
- $C_{SHUNT} = C_{PKG} + C_{PCB} + C_0$  (total shunt capacitance seen across XOSC0 and XOSC1)
- $C_{PKG}$ ,  $C_{PCB}$  as measured across the XOSC0 and XOSC1 pins excluding the crystal
- Clear the OSCDRV bit in the Hibernation Control (HIBCTL) register for  $C_{1,2} \leq 18$  pF
- Set the OSCDRV bit for  $C_{1,2} > 18$  pF
- $C_0$  = Shunt capacitance of crystal specified by the crystal manufacturer

表 5-11 lists the characteristics of the Hibernation module low-frequency oscillator.

表 5-11. Hibernation Internal Low-Frequency Oscillator Clock Characteristics

PARAMETER		MIN	NOM	MAX	UNIT
$f_{HIBLFOSC}$	Internal low-frequency hibernation oscillator frequency	10	33	90	kHz

### 5.15.4.5 Main Oscillator Specifications

表 5-12 lists the required characteristics of the main oscillator input.

表 5-12. Main Oscillator Input Characteristics

over operating free-air temperature (unless otherwise noted)<sup>(1)</sup>

PARAMETER		MIN	NOM	MAX	UNIT
$f_{MOSC}$	Parallel resonance frequency	4 <sup>(2)</sup>		25	MHz
$f_{REF\_XTAL\_BYPASS}$	External clock reference (PLL in BYPASS mode)	0		120	MHz
$C_1, C_2$	External load capacitance on OSC0, OSC1 pins <sup>(3)</sup>	12		24	pF
$C_{PKG}$	Device package stray shunt capacitance <sup>(3)</sup>		0.5		pF
$C_{PCB}$	PCB stray shunt capacitance <sup>(3)</sup>		0.5		pF
$C_{SHUNT}$	Total shunt capacitance <sup>(3)</sup>			4	pF
ESR	Crystal effective series resistance	4 MHz <sup>(4) (5)</sup>		300	$\Omega$
		6 MHz <sup>(4) (5)</sup>		200	
		8 MHz <sup>(4) (5)</sup>		130	
		12 MHz <sup>(4) (5)</sup>		120	
		16 MHz <sup>(4) (5)</sup>		100	
		25 MHz <sup>(4) (5)</sup>		50	
DL	Oscillator output drive level <sup>(6)</sup>		$OSC_{PWR}$		mW
$T_{START}$	Oscillator start-up time, when using a crystal <sup>(7)</sup>			18	ms
$V_{IH}$	CMOS input high level, when using an external oscillator	$0.65 \times V_{DD}$		$V_{DD}$	V
$V_{IL}$	CMOS input low level, when using an external oscillator	GND		$0.35 \times V_{DD}$	V
$V_{HYS}$	CMOS input buffer hysteresis, when using an external oscillator	150			mV
$DC_{OSC\_EXT}$	External clock reference duty cycle	45%		55%	

- (1) See 表 5-39 and 表 5-40 for additional Ethernet crystal requirements.
- (2) 5 MHz is the minimum when using the PLL.
- (3) See the additional information about the load capacitors following this table.
- (4) Crystal ESR specified by crystal manufacturer.
- (5) Crystal vendors can be contacted to confirm these specifications are met for a specific crystal part number if the vendors generic crystal datasheet show limits outside of these specifications.
- (6)  $OSC_{PWR} = (2 \times \pi \times F_P \times C_L \times 2.5)^2 \times ESR / 2$ . An estimation of the typical power delivered to the crystal is based on the  $C_L$ ,  $F_P$  and ESR parameters of the crystal in the circuit as calculated by the  $OSC_{PWR}$  equation. Ensure that the value calculated for  $OSC_{PWR}$  does not exceed the crystal's drive-level maximum.
- (7) Oscillator start-up time is specified from the time the oscillator is enabled to when it reaches a stable point of oscillation such that the internal clock is valid.

The load capacitors added on the board,  $C_1$  and  $C_2$ , should be chosen such that 公式 4 is satisfied (see 表 5-12 for typical values and 表 5-13 for detailed crystal parameter information).

$$C_L = (C_1 \times C_2) / (C_1 + C_2) + C_{SHUNT}$$

where

- $C_L$  = load capacitance specified by crystal manufacturer
  - $C_{SHUNT} = C_0 + C_{PKG} + C_{PCB}$  (total shunt capacitance seen across OSC0 and OSC1 crystal inputs)
  - $C_{PKG}, C_{PCB}$  = Mutual capacitance as measured across the OSC0 and OSC1 pins excluding the crystal
  - $C_0$  = Shunt capacitance of crystal specified by the crystal manufacturer
- (4)

表 5-13 lists part numbers of crystals that have been simulated and confirmed to operate within the specifications in 表 5-12. Other crystals that have nearly identical crystal parameters can be expected to work as well.

In 表 5-13, the crystal parameters labeled  $C_0$ ,  $C_1$ , and  $L_1$  are values that are obtained from the crystal manufacturer. These numbers are usually a result of testing a relevant batch of crystals on a network analyzer. The parameters labeled ESR, DL, and  $C_L$  are maximum numbers usually available in the data sheet for a crystal.

表 5-13 also includes three columns of Recommended Component Values. These values apply to system board components.  $C_1$  and  $C_2$  are the values in picofarads of the load capacitors that should be put on each leg of the crystal pins to ensure oscillation at the correct frequency.  $R_s$  is the value in  $k\Omega$  of a resistor that is placed in series with the crystal between the OSC1 pin and the crystal pin.  $R_s$  dissipates some of the power so the Max DL crystal parameter is not exceeded. Only use the recommended  $C_1$ ,  $C_2$ , and  $R_s$  values with the associated crystal part. The values in the table were used in the simulation to ensure crystal start-up and to determine the worst-case drive level (WC DL). The value in the WC DL column should not be greater than the Max DL crystal parameter. The WC DL value can be used to determine if a crystal with similar parameter values but a lower Max DL value is acceptable.

表 5-13. Crystal Parameters

Manufacturer	Manufacturer Part Number	Holder	Package Size (mm x mm)	Frequency (MHz)	Crystal Specification (Tolerance / Stability)	Crystal Parameters						Recommended Component Values			WC DL (μW)
						Typical Values			Max Values			C <sub>1</sub> (pF)	C <sub>2</sub> (pF)	R <sub>s</sub> (kΩ)	
						C <sub>0</sub> (pF)	C <sub>1</sub> (fF)	L <sub>1</sub> (mH)	ESR (Ω)	Max DL (μW)	C <sub>L</sub> (pf)				
NDK	NX8045GB-4.000M-STD-CJL-5	NX8045GB	8 x 4.5	4	30 / 50 ppm	1.00	2.70	598.10	300	500	8	12	12	0	132
FOX	FQ1045A-4	2-SMD	10 x 4.5	4	30 / 30 ppm	1.18	4.05	396.00	150	500	10	14	14	0	103
NDK	NX8045GB-5.000M-STD-CSF-4	NX8045GB	8 x 4.5	5	30 / 50 ppm	1.00	2.80	356.50	250	500	8	12	12	0	164
NDK	NX8045GB-6.000M-STD-CSF-4	NX8045GB	8 x 4.5	6	30 / 50 ppm	1.30	4.10	173.20	250	500	8	12	12	0	214
FOX	FQ1045A-6	2-SMD	10 x 4.5	6	30 / 30 ppm	1.37	6.26	112.30	150	500	10	14	14	0	209
NDK	NX8045GB-8.000M-STD-CSF-6	NX8045GB	8 x 4.5	8	30 / 50 ppm	1.00	2.80	139.30	200	500	8	12	12	0	277
FOX	FQ7050B-8	4-SMD	7 x 5	8	30 / 30 ppm	1.95	6.69	59.10	80	500	10	14	14	0	217
ECS	ECS-80-16-28A-TR	HC49/US	12.5 x 4.85	8	50 / 30 ppm	1.82	4.90	85.70	80	500	16	24	24	0	298
Abracon	AABMM-12.000MHZ-10-D-1-X-T	ABMM	7.2 x 5.2	12	10 / 20 ppm	2.37	8.85	20.5	50	500	10	12	12	2.0 <sup>(1)</sup>	124
NDK	NX3225GA-12.000MHZ-STD-CRG-2	NX3225GA	3.2 x 2.5	12	20 / 30 ppm	0.70	2.20	81.00	100	200	8	12	12	2.5	147
NDK	NX5032GA-12.000MHZ-LN-CD-1	NX5032GA	5 x 3.2	12	30 / 50 ppm	0.93	3.12	56.40	120	500	8	12	12	0	362
FOX	FQ5032B-12	4-SMD	5 x 3.2	12	30 / 30 ppm	1.16	4.16	42.30	80	500	10	14	14	0	370
Abracon	AABMM-16.000MHZ-10-D-1-X-T	ABMM	7.2 x 5.2	16	10 / 20 ppm	3.00	11.00	9.30	50	500	10	12	12	2.0 <sup>(1)</sup>	143
Ecliptek	ECX-6595-16.000M	HC-49/UP	13.3 x 4.85	16	15 / 30 ppm	3.00	12.7	8.1	50	1000	10	12	12	2.0 <sup>(1)</sup>	139
NDK	NX3225GA-16.000MHZ-STD-CRG-2	NX3225GA	3.2 x 2.5	16	20 / 30 ppm	1.00	2.90	33.90	80	200	8	12	12	2	188
NDK	NX5032GA-16.000MHZ-LN-CD-1	NX5032GA	5 x 3.2	16	30 / 50 ppm	1.02	3.82	25.90	120 <sup>(2)</sup>	500	8	10	10	0	437
ECS	ECS-160-9-42-CKM-TR	ECX-42	4 x 2.5	16	10 / 10 ppm	1.47	3.90	25.84	60	300	9	12	12	0.5	289
Abracon	AABMM-25.000MHZ-10-D-1-X-T	ABMM	7.2 x 5.2	25	10 / 20 ppm	3.00	11.00	3.70	50	500	10	12	12	2.0 <sup>(1)</sup>	158
Ecliptek	ECX-6593-25.000M	HC-49/UP	13.3 x 4.85	25	15 / 30 ppm	3.00	12.8	3.2	40	1000	10	12	12	1.5 <sup>(1)</sup>	159
NDK	NX3225GA-25.000MHZ-STD-CRG-2	NX3225GA	3.2 x 2.5	25	20 / 30 ppm	1.10	4.70	8.70	50	200	8	12	12	2	181

(1) R<sub>s</sub> values as low as 0 Ω can be used. Using a lower R<sub>s</sub> value causes the WC DL to increase toward the maximum DL of the crystal.

(2) Although this ESR value is outside of the recommended crystal ESR maximum for this frequency, this crystal has been simulated to confirm proper operation and is valid for use with this device.

表 5-13. Crystal Parameters (continued)

Manufacturer	Manufacturer Part Number	Holder	Package Size (mm × mm)	Frequency (MHz)	Crystal Specification (Tolerance / Stability)	Crystal Parameters						Recommended Component Values			WC DL (μW)
						Typical Values			Max Values			C <sub>1</sub> (pF)	C <sub>2</sub> (pF)	R <sub>s</sub> (kΩ)	
						C <sub>0</sub> (pF)	C <sub>1</sub> (fF)	L <sub>1</sub> (mH)	ESR (Ω)	Max DL (μW)	C <sub>L</sub> (pf)				
NDK	NX5032GA-25.000MHZ-LD-CD-1	NX5032GA	5 × 3.2	25	30 / 50 ppm	1.3	5.1	7.1	70	500	8	10	10	1.0 <sup>(1)</sup>	216
												12	12	0.75 <sup>(3)</sup>	269
AURIS	Q-25.000M-HC3225/4-F-30-30-E-12-TR	HC3225/4	3.2 × 2.5	25	30 / 30 ppm	1.58	5.01	8.34	50	500	12	16	16	1	331
FOX	FQ5032B-25	4-SMD	5 × 3.2	25	30 / 30 ppm	1.69	7.92	5.13	50	500	10	14	14	0.5	433
TXC	7A2570018	NX5032GA	5 × 3.2	25	20 / 25 ppm	2.0	6.7	6.1	30	350	10	12	12	2.0 <sup>(3)</sup>	124

(3) R<sub>s</sub> values as low as 500 Ω can be used. Using a lower R<sub>s</sub> value causes the WC DL to increase toward the maximum DL of the crystal.



#### 5.15.4.6 Main Oscillator Specification With ADC

表 5-14 lists the system clock characteristics with ADC operation.

表 5-14. System Clock Characteristics With ADC Operation

PARAMETER		MIN	NOM	MAX	UNIT
$f_{\text{sysadc}}$	System clock frequency when the ADC module is operating (when PLL is bypassed)		16		MHz

#### 5.15.4.7 System Clock Characteristics With USB Operation

表 5-15 lists the system clock characteristics with USB operation.

表 5-15. System Clock Characteristics With USB Operation

PARAMETER		MIN	NOM	MAX	UNIT
$f_{\text{sysusb}}$	System clock frequency when the USB module is operating (MOSC must be the clock source, either with or without using the PLL)	30			MHz

### 5.15.5 Sleep Modes

The following tables can be used to calculate the maximum wake time from sleep or deep sleep mode, depending on the specific application. Depending on the application configuration, each parameter, except for  $t_{\text{FLASH}}$ , adds sequential latency to the wake time. Flash restoration happens in parallel to the other wake processes, and its wake time is normally absorbed by the other latencies. As an example, the wake time for a device in deep sleep mode with the PIOSC and PLL turned off and the flash and SRAM in low-power mode is calculated by 公式 5.

$$\text{Wake Time} = t_{\text{PIOSCDs}} + t_{\text{PLLDS}} + t_{\text{SRAMLpDS}} \quad (5)$$

$t_{\text{FLASH}}$  does not contribute to this equation because the values of the other parameters are greater.

In sleep mode, the wake time due to a clock source is zero because the device uses the same clock configuration in run mode; thus, there is no latency involved with respect to the clocks.

表 5-16 lists the wake-up times from sleep mode.

表 5-16. Wake From Sleep Characteristics

over operating free-air temperature (unless otherwise noted)

NO.	PARAMETER		MIN	TYP	MAX	UNIT
D1	$t_{\text{PIOSC}}$	Time to restore PIOSC as system clock in sleep mode			N/A	$\mu\text{s}$
D2	$t_{\text{MOSC}}$	Time to restore MOSC as system clock in sleep mode			N/A	$\mu\text{s}$
D3	$t_{\text{PLL}}$	Time to restore PLL as system clock in sleep mode			N/A	$\mu\text{s}$
D4	$t_{\text{LDO}}$	Time to restore LDO to 1.2 V in sleep mode			39	$\mu\text{s}$
D5	$t_{\text{FLASH}}$	Time to restore flash to active state from low-power state in sleep mode			96	$\mu\text{s}$
D6	$t_{\text{SRAMLp}}$	Time to restore SRAM to active state from low-power state in sleep mode			15	$\mu\text{s}$
D7	$t_{\text{SRAMSTBY}}$	Time to restore SRAM to active state from standby state in sleep mode			15	$\mu\text{s}$

表 5-16 lists the wake-up times from deep sleep mode.

**表 5-17. Wake From Deep Sleep Characteristics**

over operating free-air temperature (unless otherwise noted)

NO.	PARAMETER	MIN	TYP	MAX	UNIT
D8	$t_{PIOSCDS}$ Time to restore PIOSC as system clock in deep sleep mode			14	deep-sleep clock cycles
D9	$t_{MOSCDS}$ Time to restore MOSC as system clock in deep sleep mode			18	ms
D10	$t_{PLLDS}$ Time to restore PLL as system clock in deep sleep mode			1 cycle of deep sleep clock + 512 cycles of PLL reference clock <sup>(1)</sup>	clock cycles
D11	$t_{LDODS}$ Time to restore LDO to 1.2 V in deep sleep mode			39	$\mu$ s
D12	$t_{FLASHLPDS}$ Time to restore flash to active state from low-power state			96	$\mu$ s
D13	$t_{SRAML PDS}$ Time to restore SRAM to active state from low-power state			15	$\mu$ s
D14	$t_{SRAMSTBYDS}$ Time to restore SRAM to active state from standby state			15	$\mu$ s

(1) Deep sleep clock can vary. See the *System Control* chapter of the [MSP432E4 SimpleLink™ Microcontrollers Technical Reference Manual](#) for the deep sleep clock options.

### 5.15.6 Hibernation Module

The Hibernation module requires special system implementation considerations because it is intended to power down all other sections of its host device. See the *Hibernation Module* chapter of the [MSP432E4 SimpleLink™ Microcontrollers Technical Reference Manual](#).

表 5-18 lists the required characteristics of the Hibernation module battery.

**表 5-18. Hibernation Module Battery Characteristics**

over operating free-air temperature (unless otherwise noted)

PARAMETER		MIN	NOM	MAX	UNIT	
$V_{BAT}$	Battery supply voltage	1.8	3.0	3.6	V	
$V_{BATRMP}$	$V_{BAT}$ battery supply voltage ramp time	0		0.7	V/ $\mu$ s	
$V_{LOWBAT}$	Low-battery detect voltage	VBATSEL = 0x0	1.8	1.9	2.0	V
		VBATSEL = 0x1	2.0	2.1	2.2	
		VBATSEL = 0x2	2.2	2.3	2.4	
		VBATSEL = 0x3	2.4	2.5	2.6	

表 5-19 lists the timing characteristics of the HIB module.

表 5-19. Hibernation Module Characteristics

over operating free-air temperature (unless otherwise noted) (see 图 5-13)

NO.	PARAMETER		MIN	TYP	MAX	UNIT
H1	$t_{WAKE}$	$\overline{WAKE}$ assertion time	100			ns
H2	$t_{WAKE\_TO\_HIB}$	$\overline{WAKE}$ assert to $\overline{HIB}$ desassert (wake-up time)			1	HIB module clock period
H3	$t_{VDD\_RAMP}$	$V_{DD}$ ramp to 3.0 V		See (1)		$\mu$ s
H4	$t_{VDD\_CODE}$	$V_{DD}$ at 3 V to internal POR deassert; first instruction executes			500	$\mu$ s
H5	DC <sub>RTCCLK</sub>	Duty cycle for RTCCLK output signal, when using a 32.768-kHz crystal	40%		60%	
		Duty cycle for RTCCLK output signal, when using a 32.768-kHz external single-ended (bypass) clock source	30%		70%	

(1) Depends on characteristics of power supply.



图 5-13. Hibernation Module Timing

表 5-20 lists the characteristics of the HIB module tamper detection.

表 5-20. Hibernation Module Tamper I/O Characteristics

over operating free-air temperature (unless otherwise noted)

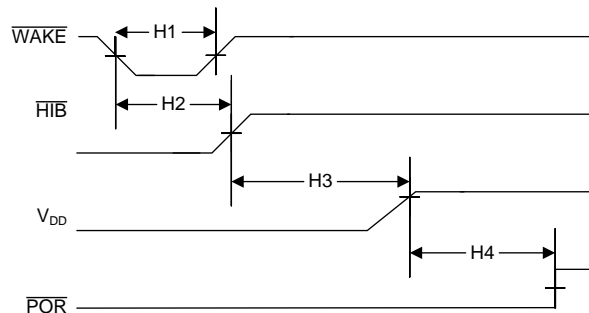
PARAMETER		MIN	TYP	MAX	UNIT
$R_{TPU}$	TMPRn pullup resistor	3.5	4.4	5.2	M $\Omega$
$t_{SP}$	TMPRn pulse duration with short glitch filter	62			$\mu$ s
$t_{LP}$	TMPRn pulse duration with long glitch filter	94			ms
$t_{NMIS}$	TMPRn assertion to NMI (short glitch filter)			95	$\mu$ s
$t_{NMIL}$	TMPRn assertion to NMI (long glitch filter)			94	ms
$V_{IH}$	TMPRn high-level input voltage when operating from $V_{BAT}$	$V_{BAT}$ $\times 0.8$			V

### 5.15.7 Flash Memory

表 5-21 lists the characteristics of the flash memory.

表 5-21. Flash Memory Characteristics

over operating free-air temperature (unless otherwise noted)

PARAMETER		MIN	TYP	MAX	UNIT
PE <sub>CYC</sub>	Number of program and erase cycles	100000			cycles
t <sub>RET</sub>	Data retention with 100% power-on hours at T <sub>J</sub> = 85°C	20			years
t <sub>RET_EXT</sub>	Data retention with 10% power-on hours at T <sub>J</sub> = 125°C and 90% power-on hours at T <sub>J</sub> = 100°C	11			years
t <sub>PROG64</sub>	Program time for double-word-aligned (64 bits) data	30	100	300	μs
t <sub>ERASE</sub>	Page erase time	<1k cycles	8	15	ms
		10k cycles	15	40	
		100k cycles	75	500	
t <sub>ME</sub>	Mass erase time	<1k cycles	10	25	ms
		10k cycles	20	70	
		100k cycles	300	2500	

### 5.15.8 EEPROM

表 5-22 lists the characteristics of the EEPROM.

表 5-22. EEPROM Characteristics

over operating free-air temperature (unless otherwise noted)

PARAMETER		MIN	TYP	MAX	UNIT
EPE <sub>CYC</sub>	Number of mass program and erase cycles of a single word	500000			cycles
ET <sub>RET</sub>	Data retention with 100% power-on hours at T <sub>J</sub> = 85°C	20			years
ET <sub>RET_EXT</sub>	Data retention with 10% power-on hours at T <sub>J</sub> = 125°C and 90% power-on hours at T <sub>J</sub> = 100°C	11			years
ET <sub>PROG</sub>	Program time for 32 bits of data with memory space available		110	600	μs
	Program time for 32 bits of data in which a copy to the copy buffer is required, the copy buffer has space, and less than 10% of EEPROM endurance used		30		ms
	Program time for 32 bits of data in which a copy to the copy buffer is required, the copy buffer has space, and more than 90% of EEPROM endurance used			900	
	Program time for 32 bits of data in which a copy of the copy buffer is required, the copy buffer requires an erase, and less than 10% of EEPROM endurance used		60		
	Program time for 32 bits of data a copy to the copy buffer is required, the copy buffer requires an erase, and more than 90% of EEPROM endurance used			1800	
ET <sub>READ</sub>	Read access time		7 + 2EWS	9 + 4EWS	system clock cycles
ET <sub>ME</sub>	Mass erase time	<1k cycles	8	15	ms
		10k cycles	15	40	
		100k cycles	75	500	

### 5.15.9 Input/Output Pin Characteristics

---

注

All GPIO signals are 3.3-V tolerant, except for PB1 (USB0VBUS) which is 5-V tolerant. See the *General-Purpose Input/Outputs (GPIOs)* chapter of the [MSP432E4 SimpleLink™ Microcontrollers Technical Reference Manual](#) for more information on GPIO configuration.

---

Two types of pads are provided on the device:

- Fast GPIO pads: These pads provide variable, programmable drive strength and optimized voltage output levels.
  - Slow GPIO pads: These pads provide 2-mA drive strength and are designed to be sensitive to voltage inputs. The following GPIOs port pins are designed with slow GPIO pads:
    - PJ1
- 

注

Port pins PL6 and PL7 operate as fast GPIO pads, but have 4-mA drive capability only. GPIO register controls for drive strength, slew rate, and open drain have no effect on these pins. The following registers have no effect: GPIODR2R, GPIODR4R, GPIODR8R, GPIODR12R, GPIOSLR, and GPIOODR.

---

注

Port pins PM[7:4] operate as fast GPIO pads but support *only* 2-, 4-, 6-, and 8-mA drive capability. All standard GPIO register controls, except for the GPIODR12R register, apply to these port pins.

---

表 5-23 lists the characteristics of the fast GPIOs.

**表 5-23. Fast GPIO Module Characteristics**

over operating free-air temperature (unless otherwise noted) <sup>(1)</sup> <sup>(2)</sup> <sup>(3)</sup> <sup>(4)</sup>

PARAMETER		MIN	TYP	MAX	UNIT
C <sub>LGPIO</sub>	Capacitive loading for measurements given in this table <sup>(5)</sup>			50	pF
R <sub>GPIOPU</sub>	Fast GPIO internal pullup resistor <sup>(6)</sup>	12.1	16.0	20.2	kΩ
R <sub>GPIOPU4MA</sub>	Fast GPIO PL6 and PL7 (4 mA only) pullup resistor	25		40	kΩ
R <sub>GPIOPD</sub>	Fast GPIO internal pulldown resistor <sup>(6)</sup>	13.0	20.5	35.5	kΩ
R <sub>GPIOPD4MA</sub>	Fast GPIO PL6 and PL7 (4 mA only) pulldown resistor	10	14.3	17	kΩ
I <sub>LKG+</sub>	Fast GPIO input leakage current, 0 V ≤ V <sub>IN</sub> ≤ V <sub>DD</sub> GPIO pins <sup>(7)</sup>			400	nA
	Fast GPIO input leakage current, 0 V < V <sub>IN</sub> ≤ V <sub>DD</sub> , fast GPIO pins configured as ADC or analog comparator inputs			400	
I <sub>INJ-</sub>	DC injection current, V <sub>IN</sub> ≤ 0 V			60	μA
I <sub>MAXINJ-</sub>	Maximum negative injection if not voltage protected <sup>(8)</sup>			-0.5	mA
t <sub>GPIOR</sub>	Fast GPIO rise time <sup>(9)</sup>	2-mA drive	7.85	11.73	ns
		4-mA drive	4.15	6.35	
		8-mA drive	2.33	3.73	
		8-mA drive with slew rate control	3.77	5.76	
		10-mA drive	1.98	3.22	
		12-mA drive	1.75	2.9	
t <sub>GPIOF</sub>	Fast GPIO fall time <sup>(10)</sup>	2-mA drive	10.3	16.5	ns
		4-mA drive	5.15	8.29	
		8-mA drive	2.58	4.16	
		8-mA drive with slew rate control	3.54	5.55	
		10-mA drive	2.07	3.34	
		12-mA drive	1.73	2.78	

(1) V<sub>DD</sub> must be within the range specified in [Section 5.4](#).

(2) Leakage and Injection current characteristics specified in this table also apply to XOSC0 and XOSC1 inputs.

(3) For the external reference inputs of the ADC, avoid a current-limiting resistor (see the I<sub>VREF</sub> specification in [表 5-33](#)).

(4) I/O pads should be protected if the I/O voltage may go outside the limits shown in the table. If the part is unpowered, the I/O pad voltage or current must be limited (as shown in this table) to avoid powering the part through the I/O pad, which can potentially cause irreversible damage.

(5) See the individual peripheral sections for specific loading information.

(6) This value includes all GPIO except for port pins PL6 and PL7.

(7) The leakage current is measured with V<sub>IN</sub> applied to the corresponding pins. The leakage of digital port pins is measured individually. The port pin is configured as an input and the pullup/pulldown resistor is disabled.

(8) If the I/O pad is not voltage limited, it should be current limited (to I<sub>INJ+</sub> + and I<sub>INJ-</sub>) if there is any possibility of the pad voltage exceeding the V<sub>IO</sub> limits (including transient behavior during supply ramp up, or at any time when the part is unpowered).

(9) Time measured from 20% to 80% of V<sub>DD</sub>.

(10) Time measured from 80% to 20% of V<sub>DD</sub>.

表 5-24 lists the characteristics of the slow GPIOs.

**表 5-24. Slow GPIO Module Characteristics**

over operating free-air temperature (unless otherwise noted)<sup>(1)(2)(3)</sup>

PARAMETER		MIN	TYP	MAX	UNIT
C <sub>LGPIO</sub>	Capacitive loading for measurements given in this table <sup>(4)</sup>			50	pF
R <sub>GPIOPU</sub>	Slow GPIO internal pullup resistor	13.8	20.0	31.4	kΩ
R <sub>GPIOPD</sub>	Slow GPIO internal pulldown resistor	13.0	20.5	35.5	kΩ
I <sub>LKG+</sub>	Slow GPIO input leakage current, 0 V ≤ V <sub>IN</sub> ≤ V <sub>DD</sub> , GPIO pins <sup>(5)</sup>			3.25	nA
	Slow GPIO input leakage current, 0 V < V <sub>IN</sub> ≤ V <sub>DD</sub> , GPIO pins configured as ADC or analog comparator inputs			3.25	
I <sub>INJ-</sub>	DC injection current, V <sub>IN</sub> ≤ 0 V			3.42	μA
t <sub>GPIOR</sub>	Slow GPIO rise time, 2-mA drive <sup>(6)</sup>		19.3	29.8	ns
t <sub>GPIOF</sub>	Slow GPIO fall time, 2-mA drive <sup>(7)</sup>		12.8	21.1	ns

(1) V<sub>DD</sub> must be within the range specified in [Section 5.4](#).

(2) V<sub>IN</sub> must be within the range specified in [Section 5.1](#). Leakage current outside of this maximum voltage is not ensured and can result in permanent damage of the device.

(3) To avoid potential damage to the part, externally limit either the voltage or current on the I/Os other than power and  $\overline{WAKE}$  as listed in this table.

(4) See the individual peripheral sections for specific loading information.

(5) The leakage current is measured with V<sub>IN</sub> applied to the corresponding pins. The leakage of digital port pins is measured individually. The port pin is configured as an input and the pullup/pulldown resistor is disabled.

(6) Time measured from 20% to 80% of V<sub>DD</sub>.

(7) Time measured from 80% to 20% of V<sub>DD</sub>.

### 5.15.9.1 Types of I/O Pins and ESD Protection

#### CAUTION

All device I/Os pins, except for PB1, are NOT 5-V tolerant; voltages in excess of the limits in [Section 5.4](#) can permanently damage the device. PB1 is used for the USB0VBUS signal, which requires a 5-V input.

#### 5.15.9.1.1 Hibernate $\overline{WAKE}$ pin

The Hibernate  $\overline{WAKE}$  pin uses ESD protection, similar to the one shown in [图 5-14](#). This ESD protection prevents a direct path between this pad and any power supply rails in the device. The  $\overline{WAKE}$  pad input voltage should be kept inside the maximum ratings specified in [Section 5.1](#) to ensure current leakage and current injections are within acceptable range. [表 5-25](#) lists current leakages and current injection for these pins.



图 5-14. ESD Protection

表 5-25. Pad Voltage and Current Characteristics for Hibernate  $\overline{WAKE}$  Pin

over operating free-air temperature (unless otherwise noted)<sup>(1)(2)</sup>

PARAMETER	MIN	TYP	MAX	UNIT
$I_{LKG+}$ Positive I/O leakage for $V_{DD} \leq V_{IN} \leq V_{BAT} + 0.3$ V			300	nA
$I_{LKG-}$ Negative I/O leakage for $-0.3$ V $\leq V_{IN} \leq 0$ V <sup>(3)</sup>			43.3	$\mu$ A
$I_{INJ+}$ Maximum positive injection if not voltage protected			2	mA
$I_{INJ-}$ Maximum negative injection if not voltage protected <sup>(4)</sup>			-0.5	mA

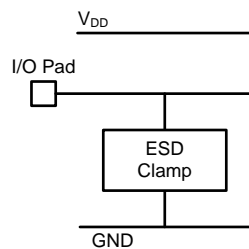
- (1)  $V_{IN}$  must be within the range specified in [Section 5.1](#). Leakage current outside of this maximum voltage is not ensured and can result in permanent damage of the device.
- (2) VDD must be within the range specified in [Section 5.4](#).
- (3) Leakage outside the minimum range ( $-0.3$  V) is unbounded and must be limited to  $I_{INJ-}$  using an external resistor.
- (4) If the I/O pad is not voltage limited, it should be current limited (to  $I_{INJ+}$  and  $I_{INJ-}$ ) if there is any possibility of the pad voltage exceeding the  $V_{IO}$  limits (including transient behavior during supply ramp up, or at any time when the part is unpowered).



### 5.15.9.1.2 Nonpower I/O Pins

Most nonpower I/Os (with the exception of the I/O pad for Hibernate  $\overline{\text{WAKE}}$  input) have ESD protection as shown in 图 5-15.

These I/Os have an ESD clamp to ground and a diode connection to the corresponding power supply rail. To prevent potential damage to the device, follow the specifications in 表 5-26 for the voltage and current of these I/Os. In addition, comply with that the ADC external reference specifications in 表 5-33 to prevent gain error.



图 5-15. ESD Protection for Nonpower Pins (Except  $\overline{\text{WAKE}}$  Signal)

表 5-26. Nonpower I/O Pad Voltage and Current Characteristics

over operating free-air temperature (unless otherwise noted) <sup>(1)</sup> <sup>(2)</sup> <sup>(3)</sup>

PARAMETER		MIN	TYP	MAX	UNIT
$V_{IO}$	I/O pad voltage limits if voltage protected	-0.3	$V_{DD}$	$V_{DD} + 0.3$	V
$I_{LKG+}$	Positive I/O leakage for $V_{DD} \leq V_{IN} \leq V_{IO}$ <sup>(4)</sup>			400	nA
$I_{LKG-}$	Negative I/O leakage for $V_{IO} \text{ MIN} \leq V_{IN} \leq 0V$ <sup>(4)</sup>			60	$\mu A$
$I_{INJ+}$	Maximum positive injection if not voltage protected <sup>(5)</sup>			2	mA
$I_{INJ-}$	Maximum negative injection if not voltage protected <sup>(5)</sup>			-0.5	mA

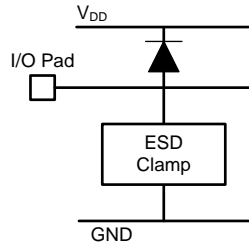
- (1) To avoid potential damage to the part, externally limit either the voltage or current on I/Os other than power and  $\overline{\text{WAKE}}$  as listed in this table.
- (2) For the external reference inputs of the ADC, avoid a current-limiting resistor (see the  $I_{VREF}$  specification in 表 5-33).
- (3) I/O pads should be protected if at any point the I/O voltage has a possibility of going outside the limits shown in the table. If the part is unpowered, the I/O pad voltage and current must be limited (as shown in this table) to avoid powering the part through the I/O pad, which can potentially cause irreversible damage.
- (4) MIN and MAX leakage current for the case when the I/O is voltage protected to  $V_{IO} \text{ MIN}$  or  $V_{IO} \text{ MAX}$ .
- (5) If the I/O pad is not voltage limited, it should be current limited (to  $I_{INJ+}$  and  $I_{INJ-}$ ) if there is any possibility of the pad voltage exceeding the  $V_{IO}$  limits (including transient behavior during supply ramp up, or at any time when the part is unpowered).

### 5.15.10 External Peripheral Interface (EPI)

表 5-27 lists the load conditions used to characterize the EPI interface.

表 5-27. EPI Interface Load Conditions

SIGNALS	LOAD VALUE ( $C_L$ )
EPIOS[35:0] SDRAM interface	30 pF
EPIOS[35:0] General-Purpose interface	
EPIOS[35:0] Host-Bus interface	
EPIOS[35:0] PSRAM interface	40 pF

When the EPI module is in SDRAM mode, EPI CLK (EPI0S31) must be configured to 12 mA. The EPI data bus can be configured to 8 mA. 表 5-28 lists the rise and fall times in SDRAM mode.

表 5-28. EPI SDRAM Characteristics

over operating free-air temperature (unless otherwise noted)

PARAMETER	TEST CONDITIONS	MIN	TYP	MAX	UNIT
$t_{SDRAMR}$ EPI rise time (from 20% to 80% of $V_{DD}$ )	12-mA drive, $C_L = 30$ pF		2	3	ns
$t_{SDRAMF}$ EPI fall time (from 80% to 20% of $V_{DD}$ )	12-mA drive, $C_L = 30$ pF		2	3	ns

表 5-29 lists the switching characteristics of the SDRAM interface.

表 5-29. EPI SDRAM Interface Characteristics

over operating free-air temperature (unless otherwise noted) <sup>(1)</sup> (see 图 5-16, 图 5-17, and 图 5-18)

NO.	PARAMETER	MIN	TYP	MAX	UNIT
E1	$t_{CK}$ SDRAM clock period	16.67			ns
E2	$t_{CH}$ SDRAM clock high time	8.33			ns
E3	$t_{CL}$ SDRAM clock low time	8.33			ns
E4	$t_{COV}$ CLK to output valid			4	ns
E5	$t_{COI}$ CLK to output invalid			4	ns
E6	$t_{COT}$ CLK to output tristate			4	ns
E7	$t_S$ Input set up to CLK	8.5			ns
E8	$t_H$ CLK to input hold	0			ns
E9	$t_{PU}$ Power-up time	100			$\mu$ s
E10	$t_{RP}$ Precharge all banks	20			ns
E11	$t_{RFC}$ Auto refresh	66			ns
E12	$t_{MRD}$ Program mode register	2			EPI CLK

(1) The EPI SDRAM interface must use 12-mA drive.

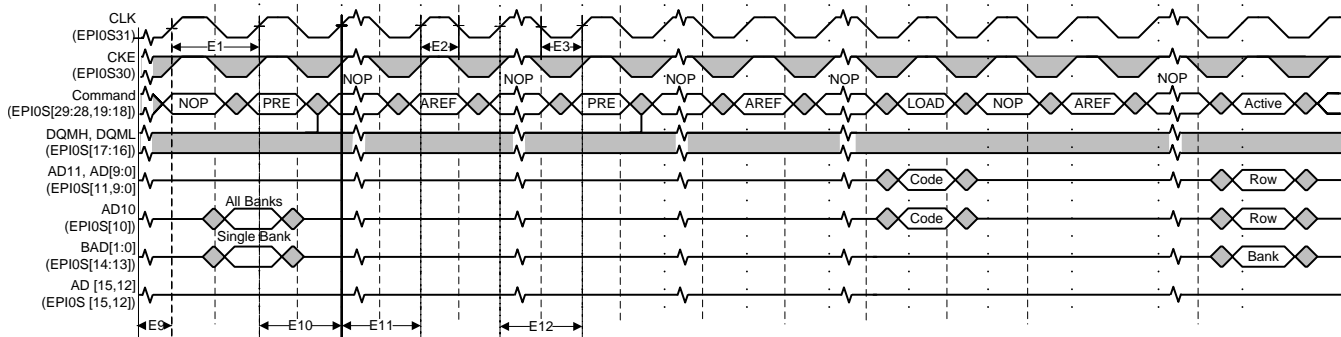

- (1) If CS is high at clock high time, all applied commands are NOP.
- (2) The Mode register can be loaded before the autorefresh cycles.
- (3) JEDEC and PC100 specify 3 clock cycles.
- (4) Outputs are Hi-Z after the command is issued.

图 5-16. SDRAM Initialization and Load Mode Register Timing



图 5-17. SDRAM Read Timing



图 5-18. SDRAM Write Timing

表 5-30 lists the characteristics of the Host-Bus 8 and Host-Bus 16 interface.

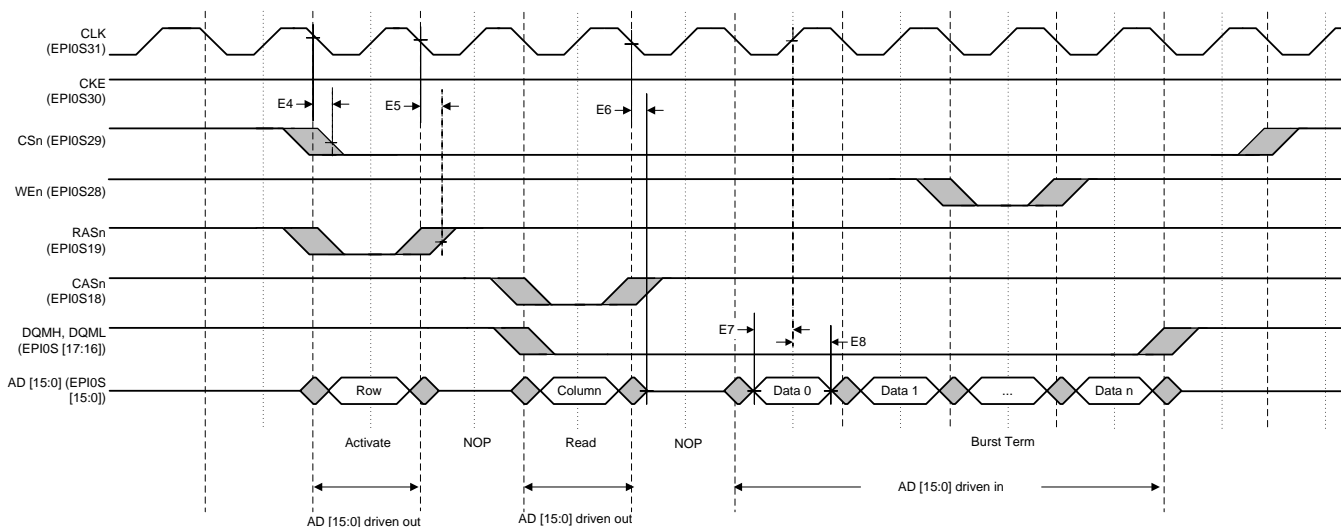
表 5-30. EPI Host-Bus 8 and Host-Bus 16 Interface Characteristics

over operating free-air temperature (unless otherwise noted) (see 图 5-19, 图 5-20, 图 5-21, and 图 5-22)

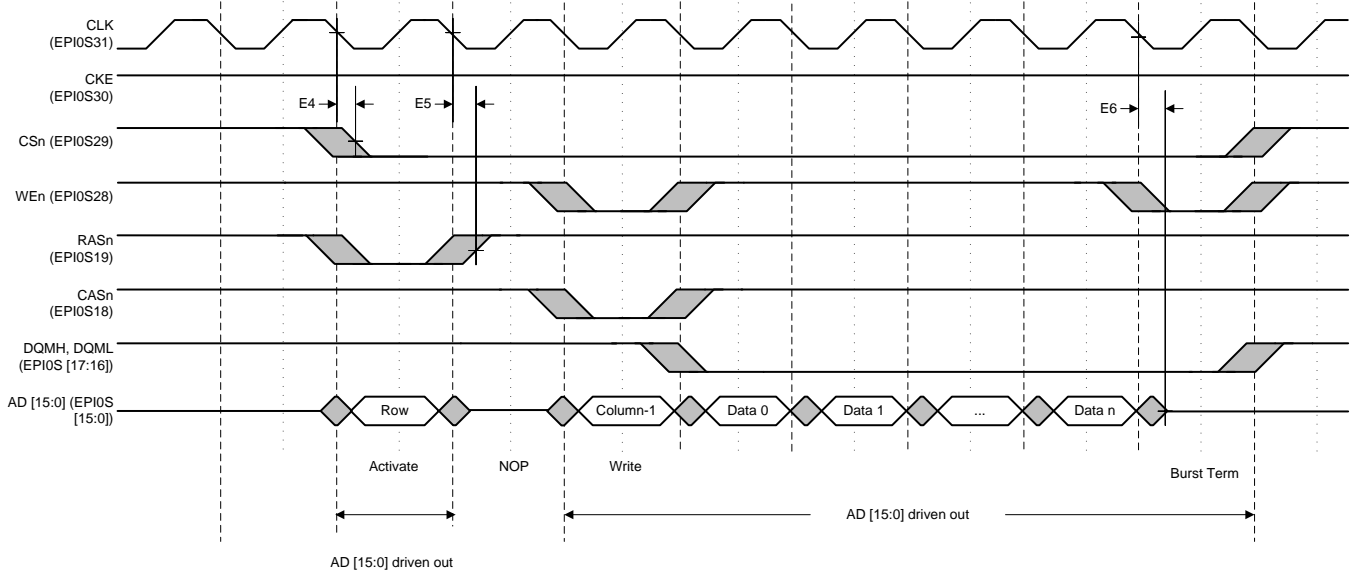
NO.	PARAMETER		MIN	TYP	MAX	UNIT
E14	$t_{ISU}$	Read data set up time	10			ns
E15	$t_{IH}$	Read data hold time	0			ns
E16	$t_{DV}$	WRn to write data valid			3.6	ns
E17	$t_{DI}$	Data hold from WRn invalid	1			EPI clock cycles
E18	$t_{OV}$	ALE/CSn to output valid			4	ns
E19	$t_{OINV}$	CSn to output invalid			4	ns
E20	$t_{STLOW}$	WRn / RDn strobe duration low	1			EPI clock cycles
E21	$t_{ALEHIGH}$	ALE duration high		1		EPI clock cycles
E22	$t_{CSLOW}$	CSn duration low	2			EPI clock cycles
E23	$t_{ALEST}$	ALE rising to WRn / RDn strobe falling	2			EPI clock cycles
E24	$t_{ALEADD}$	ALE falling to Address high impedance	1			EPI clock cycles

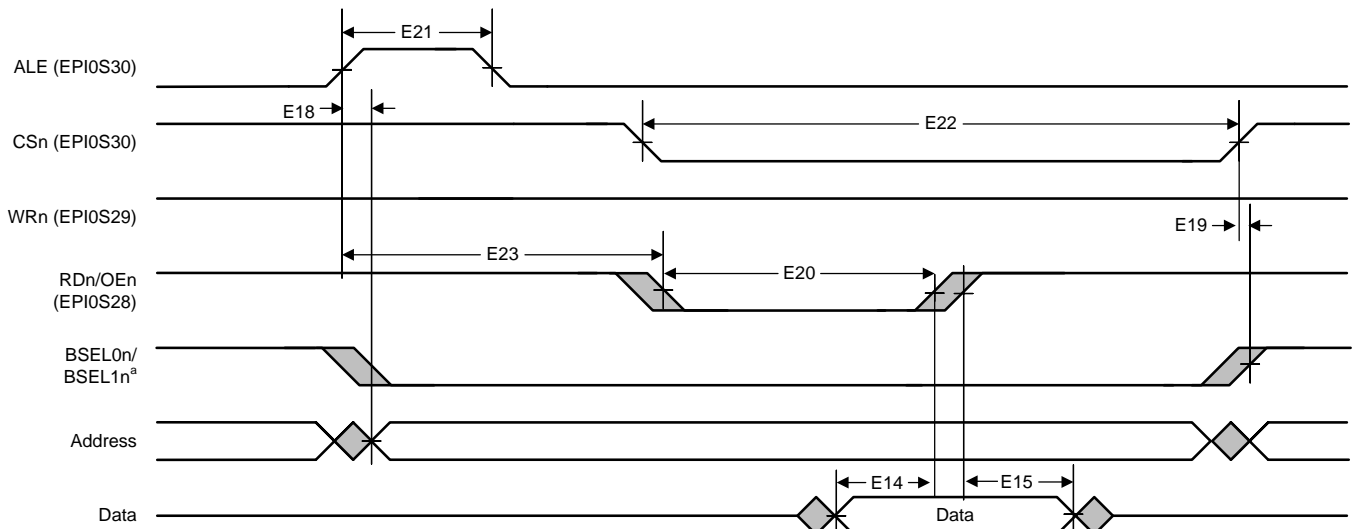

<sup>a</sup> BSEL0n and BSEL1n are available in Host-Bus 16 mode only.

图 5-19. Host-Bus 8/16 Asynchronous Mode Read Timing

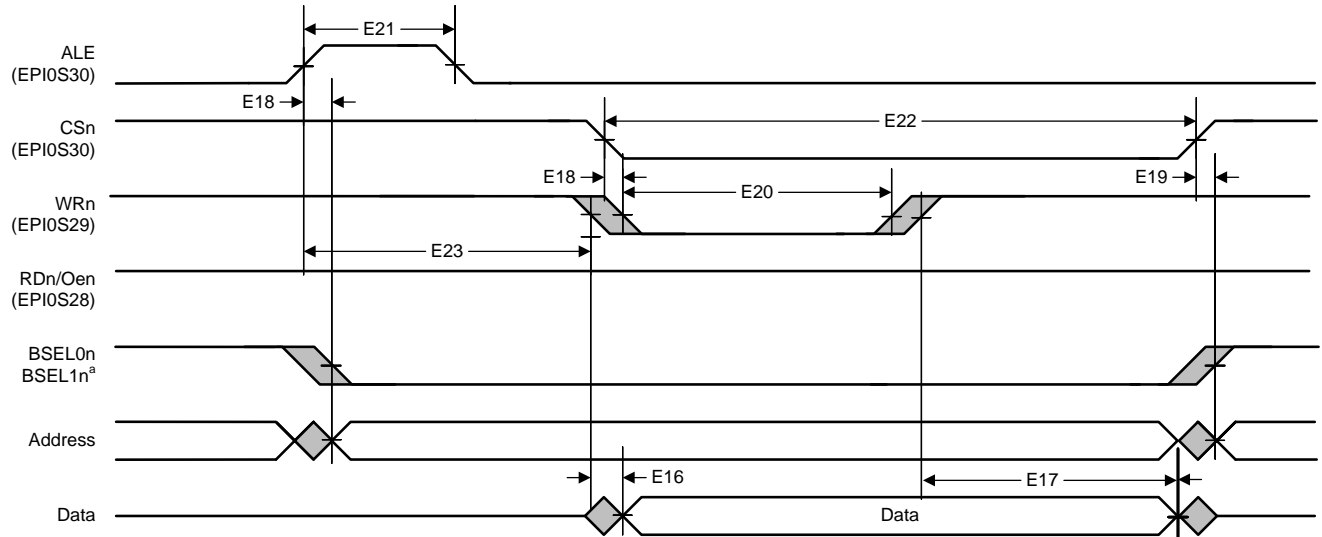

<sup>a</sup> BSEL0n and BSEL1n are available in Host-Bus 16 mode only.

图 5-20. Host-Bus 8/16 Asynchronous Mode Write Timing

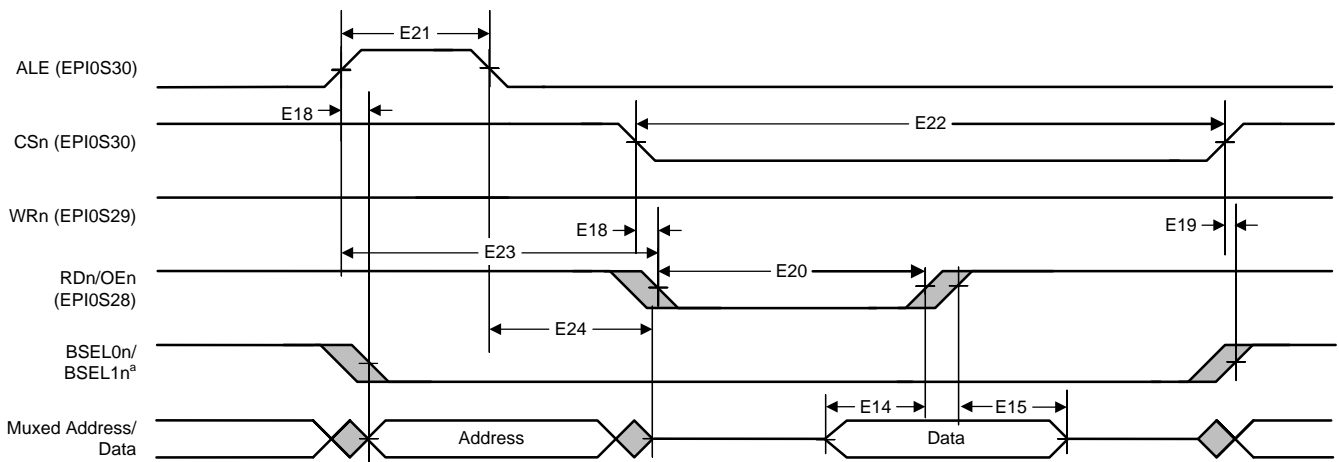

<sup>a</sup> BSEL0n and BSEL1n are available in Host-Bus 16 mode only.

图 5-21. Host-Bus 8/16 Mode Asynchronous Muxed Read Timing

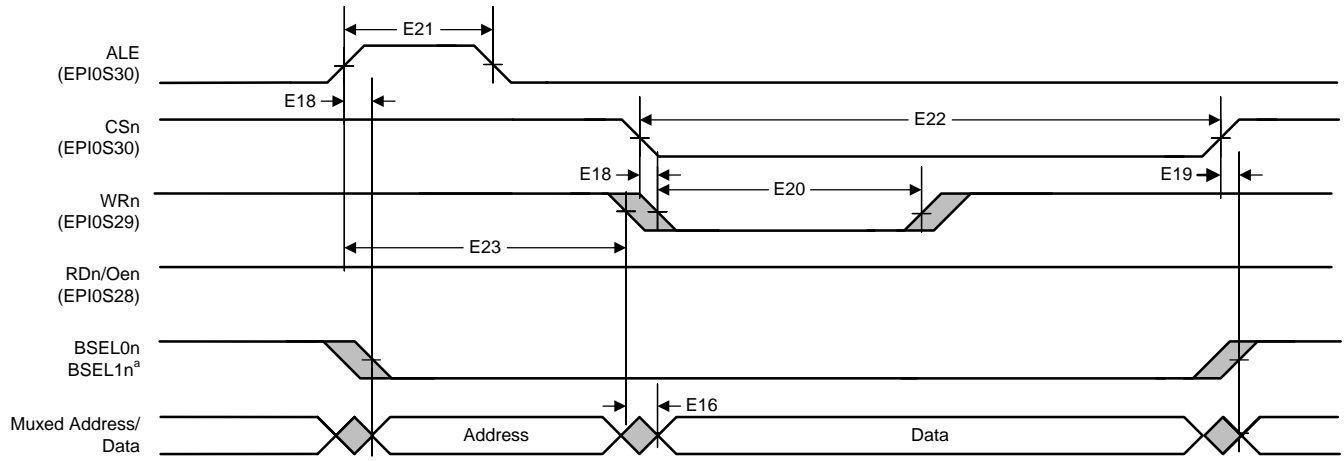

<sup>a</sup> BSEL0n and BSEL1n are available in Host-Bus 16 mode only.

图 5-22. Host-Bus 8/16 Mode Asynchronous Muxed Write Timing

表 5-31 lists the switching characteristics of the general-purpose interface.

表 5-31. EPI General-Purpose Interface Characteristics

over operating free-air temperature (unless otherwise noted) (see 图 5-23)

NO.	PARAMETER		MIN	TYP	MAX	UNIT
E25	$t_{CK}$	General-purpose clock period	16.67			ns
E26	$t_{CH}$	General-purpose clock high time	8.33			ns
E27	$t_{CL}$	General-purpose clock low time	8.33			ns
E28	$t_{ISU}$	Input signal set up time to rising clock edge	8.50			ns
E29	$t_{IH}$	Input signal hold time from rising clock edge	0			ns
E30	$t_{DV}$	Falling clock edge to output valid			4	ns
E31	$t_{DI}$	Falling clock edge to output invalid			4	ns

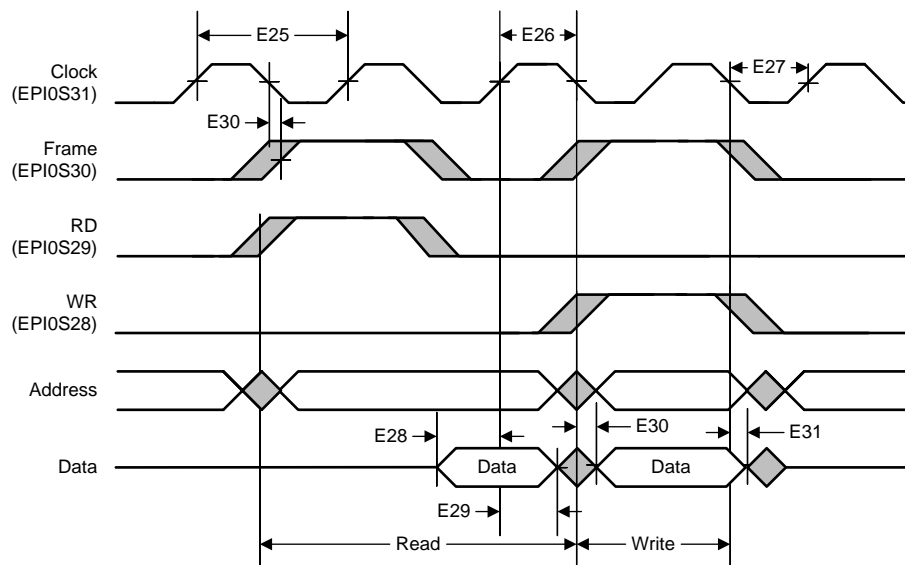

NOTE: This figure shows accesses when the FRM50 bit is clear, the FRMCNT field is 0x0, and the WR2CYC bit is clear.

图 5-23. General-Purpose Mode Read and Write Timing



表 5-32 lists the switching characteristics of the PSRAM interface.

表 5-32. EPI PSRAM Interface Characteristics

over operating free-air temperature (unless otherwise noted) (see 图 5-24 and 图 5-25)

NO.	PARAMETER		MIN	TYP	MAX	UNIT
E33	$t_{EPICLK}$	EPI_CLK period	20			ns
E34	$t_{RTFT}$	EPI_CLK rise or fall time			1.8	ns
E35	$t_{OV}$	Falling EPI_CLK to address/write data or control output valid <sup>(1)</sup>	4.5		20	ns
E36	$t_{HT}$	Falling EPI_CLK to address/write data or control hold time <sup>(1)</sup>	2			ns
E37	$t_{SUP}$	Read data setup time from EPI_CLK rising			9	ns
E38	$t_{DH}$	Read data output hold from EPI_CLK rising	0			ns
E39	$t_{IRV}$	iRDY setup time			9	ns
E40	$t_{IRH}$	iRDY hold time			9	ns

(1) Control output includes WRn, RDn, OEn, BSELn, ALE, and CSn.



图 5-24. PSRAM Single Burst Read



图 5-25. PSRAM Single Burst Write

### 5.15.11 Analog-to-Digital Converter (ADC)

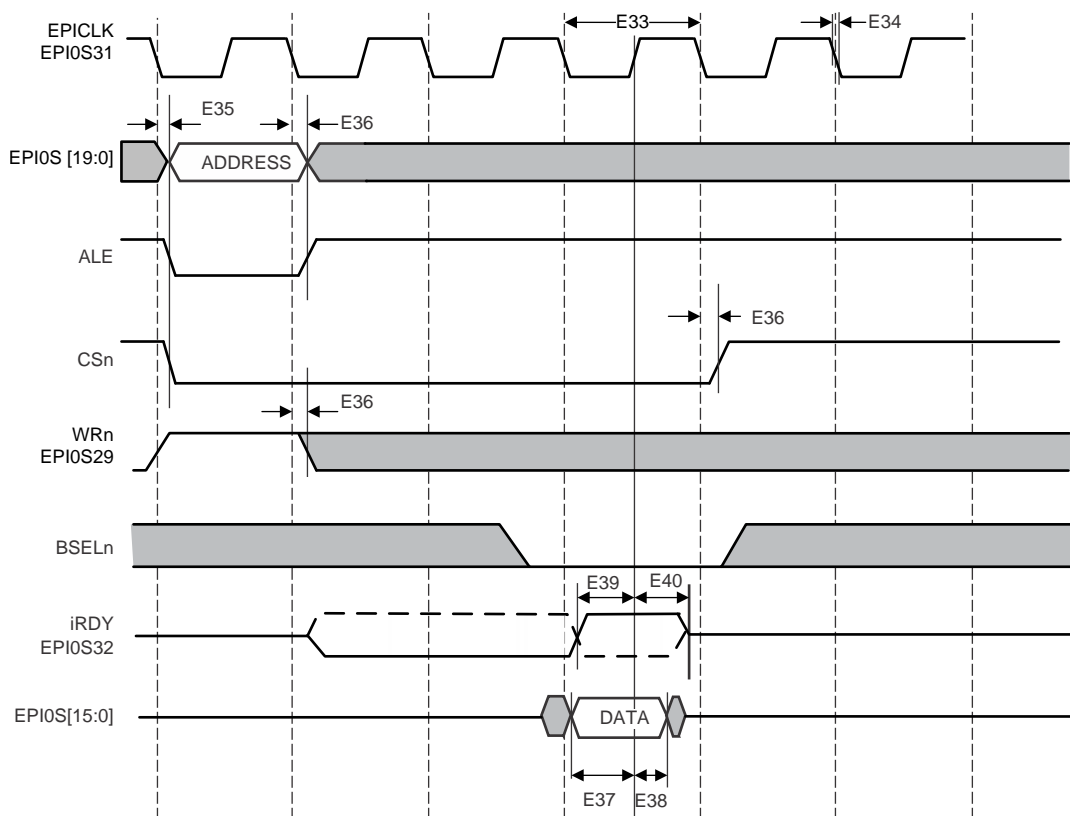
表 5-33 lists the electrical characteristics for the ADC at 1 Msps.

表 5-33. Electrical Characteristics for ADC at 1 Msps

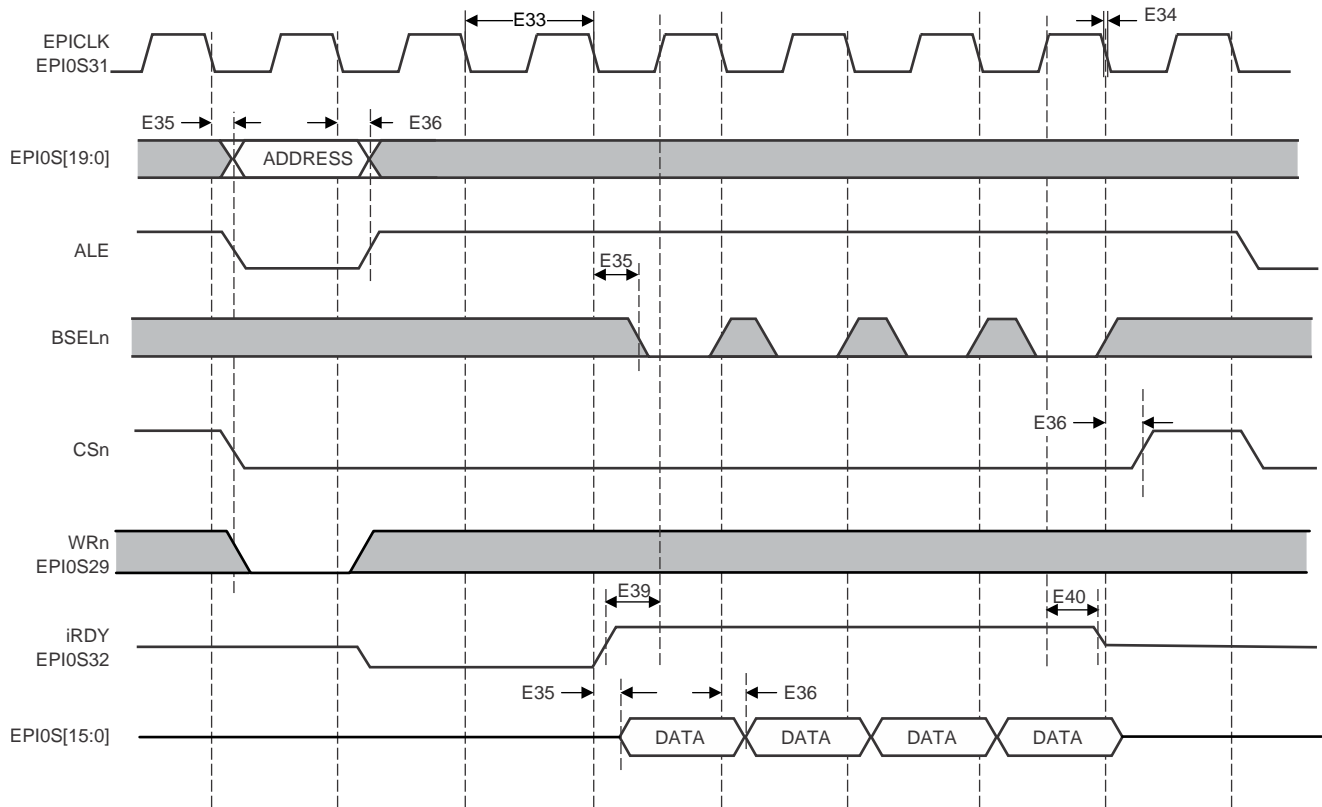
$V_{REF+} = 3.3\text{ V}$ ,  $f_{ADC} = 16\text{ MHz}$  (unless otherwise noted)<sup>(1)</sup>

PARAMETER		MIN	TYP	MAX	UNIT
<b>Power supply requirements</b>					
$V_{DDA}$	ADC supply voltage	2.97	3.3	3.63	V
$G_{NDA}$	ADC ground voltage		0		V
<b>VDDA and GNDA voltage reference</b>					
$C_{REF}$	Voltage reference decoupling capacitance		1.0 // 0.01 <sup>(2)</sup>		$\mu\text{F}$
<b>External voltage reference input</b>					
$V_{REFA+}$	Positive external voltage reference for ADC, when VREF field in the ADCCTL register is 0x1 <sup>(3)</sup>	2.4	$V_{DDA}$	$V_{DDA}$	V
$V_{REFA-}$	Negative external voltage reference for ADC, when VREF field in the ADCCTL register is 0x1 <sup>(3)</sup>	$G_{NDA}$	$G_{NDA}$	0.3	V
$I_{VREF}$	Current on VREF+ input, using external $V_{REF+} = 3.3\text{ V}$		330.5	440	$\mu\text{A}$
$I_{LVREF}$	DC leakage current on VREF+ input when external VREF disabled			2.0	$\mu\text{A}$
$C_{REF}$	External reference decoupling capacitance <sup>(3)</sup>		1.0 // 0.01 <sup>(2)</sup>		$\mu\text{F}$
<b>Analog input</b>					
$V_{ADCIN}$	Single-ended, full-scale analog input voltage, internal reference <sup>(4)(5)</sup>	0		$V_{DDA}$	V
	Differential, full-scale analog input voltage, internal reference <sup>(4)(6)</sup>	$-V_{DDA}$		$V_{VDDA}$	
	Single-ended, full-scale analog input voltage, external reference <sup>(3)(5)</sup>	$V_{REFA-}$		$V_{REFA+}$	
	Differential, full-scale analog input voltage, external reference <sup>(3)(7)</sup>	$-(V_{REFA+} - V_{REFA-})$		$V_{REFA+} - V_{REFA-}$	
$V_{INCM}$	Input common-mode voltage, differential mode <sup>(8)</sup>			$[(V_{REFA+} + V_{REFA-}) / 2] \pm 0.025$	V
$I_L$	ADC input leakage current <sup>(9)</sup>			2.0	$\mu\text{A}$
$R_{ADC}$	ADC equivalent input resistance <sup>(9)</sup>			2.5	$\text{k}\Omega$
$C_{ADC}$	ADC equivalent input capacitance <sup>(9)</sup>			10	$\text{pF}$
$R_S$	Analog source resistance <sup>(9)</sup>			500	$\Omega$
<b>Sampling dynamics</b>					
$f_{ADC}$	ADC conversion clock frequency <sup>(10)</sup>		16		MHz
$f_{CONV}$	ADC conversion rate		1		Msps
$t_S$	ADC sample time		250		ns
$t_C$	ADC conversion time <sup>(11)</sup>		1		$\mu\text{s}$

- (1) Best design practices suggest placing static or quiet digital I/O signals adjacent to sensitive analog inputs to reduce capacitive coupling and crosstalk. Unexpected results can occur if a switching digital I/O is placed adjacent to an ADC input channel or voltage reference input. In addition, analog signals that are adjacent to ADC input channels or reference inputs must meet the  $R_{ADC}$  equivalent input resistance given in this table and must be band-limited to 100 kHz or lower.
- (2) Two capacitors in parallel. These capacitors should be as close to the die as possible.
- (3) Assumes external filtering network between  $V_{REFA+}$  and  $V_{REFA-}$  as shown in 图 5-26. External reference noise level must be under 12-bit (-74 dB) full-scale input, over input bandwidth, measured at  $V_{REFA+} - V_{REFA-}$ .
- (4) Internal reference is connected directly between  $V_{DDA}$  and  $G_{NDA}$  ( $V_{REFi} = V_{DDA} - G_{NDA}$ ). In this mode,  $E_O$ ,  $E_G$ ,  $E_T$ , and dynamic specifications are adversely affected due to internal voltage drop and noise on  $V_{DDA}$  and  $G_{NDA}$ . Internal reference voltage is selected when VREF field in the ADCCTL register is 0x0.
- (5)  $V_{ADCIN} = V_{INP} - V_{INN}$
- (6) With signal common-mode voltage as  $V_{DDA} / 2$ .
- (7) With signal common-mode voltage as  $(V_{REF+} + V_{REF-}) / 2$ .
- (8) This parameter is defined as the average of the differential inputs.
- (9) As shown in 图 5-27,  $R_{ADC}$  is the total equivalent resistance in the input line all the way up to the sampling node at the input of the ADC.
- (10) See 表 5-14 for full ADC clock frequency specification.
- (11) ADC conversion time ( $t_C$ ) includes the ADC sample time ( $t_S$ ).

表 5-33. Electrical Characteristics for ADC at 1 Msps (continued)

 $V_{REF+} = 3.3\text{ V}$ ,  $f_{ADC} = 16\text{ MHz}$  (unless otherwise noted)<sup>(1)</sup>

PARAMETER		MIN	TYP	MAX	UNIT
$t_{LT}$	Latency from trigger to start of conversion		2		ADC clock cycles
<b>System performance when using external reference</b> <sup>(12) (13)</sup>					
N	Resolution		12		bits
INL	Integral nonlinearity error, over full input range		±1.5	±3.0	LSB
DNL	Differential nonlinearity error, over full input range		±0.8	+2.0/-1.0 <sup>(14)</sup>	LSB
$E_O$	Offset error		±1.0	±3.0	LSB
$E_G$	Gain error <sup>(15)</sup>		±2.0	±3.0	LSB
$E_T$	Total unadjusted error, over full input range <sup>(16)</sup>		±2.5	±4.0	LSB
<b>System performance when using internal reference</b>					
N	Resolution		12		bits
INL	Integral nonlinearity error, over full input range		±1.5	±3.0	LSB
DNL	Differential nonlinearity error, over full input range		±0.8	+2.0/-1.0 <sup>(14)</sup>	LSB
$E_O$	Offset error		±5.0	±15.0	LSB
$E_G$	Gain error <sup>(15)</sup>		±10.0	±30.0	LSB
$E_T$	Total unadjusted error, over full input range <sup>(16)</sup>		±10.0	±30.0	LSB
<b>Dynamic characteristics</b> <sup>(12) (17)</sup>					
$SNR_D$	Signal-to-noise-ratio, Differential input, $V_{ADCIN}$ : -20 dB FS, 1 kHz <sup>(18)</sup>	70	72		dB
$SDR_D$	Signal-to-distortion ratio, Differential input, $V_{ADCIN}$ : -3 dB FS, 1 kHz <sup>(18) (19) (20)</sup>	72	75		dB
$SNDR_D$	Signal-to-Noise+Distortion ratio, Differential input, $V_{ADCIN}$ : -3 dB FS, 1 kHz <sup>(18) (21) (22)</sup>	68	70		dB
$SNR_S$	Signal-to-noise-ratio, Single-ended input, $V_{ADCIN}$ : -20 dB FS, 1 kHz <sup>(23)</sup>	60	65		dB
$SDR_S$	Signal-to-distortion ratio, Single-ended input, $V_{ADCIN}$ : -3 dB FS, 1 kHz <sup>(19) (20)</sup>	70	72		dB
$SNDR_S$	Signal-to-Noise+Distortion ratio, Single-ended input, $V_{ADCIN}$ : -3 dB FS, 1 kHz <sup>(23) (21) (22)</sup>	60	63		dB
<b>Temperature sensor</b>					
$V_{TSENS}$	Temperature sensor voltage, junction temperature 25°C		1.633		V
$S_{TSENS}$	Temperature sensor slope at: -40°C to 105°C ambient (extended temperature part)		-13.3		mV/°C

(12) A low-noise environment is assumed to obtain values close to specifications. The board must have good ground isolation between analog and digital grounds and a clean reference voltage. The input signal must be band-limited to Nyquist bandwidth. No antialiasing filter is provided internally.

(13) ADC static measurements taken by averaging over several samples. At least 20-sample averaging is assumed to obtain expected typical or maximum specification values.

(14) 12-bit DNL

(15) Gain error is measured at maximum code after compensating for offset. Gain error is equivalent to the full-scale error. It can be given in % of slope error, or in LSB, as done here.

(16) Total unadjusted error is the maximum error at any one code versus the ideal ADC curve. It includes all other errors (offset error, gain error and INL) at any given ADC code.

(17) ADC dynamic characteristics are measured using low-noise board design, with low-noise reference voltage (< -74-dB noise level in signal bandwidth) and low-noise analog supply voltage. Board noise and ground bouncing couple into the ADC and affect dynamic characteristics. A clean external reference must be used to achieve the listed specifications.

(18) Differential signal with correct common-mode voltage, applied between two ADC inputs.

(19)  $SDR = -THD$  in dB.

(20) For higher-frequency inputs, expect degradation in SDR.

(21)  $SNDR = S/(N+D) = SINAD$  (in dB)

(22) Effective number of bits (ENOB) can be calculated from SNDR:  $ENOB = (SNDR - 1.76) / 6.02$ .

(23) Single-ended inputs are more sensitive to board and trace noise than differential inputs; SNR and SNDR measurements on single-ended inputs are highly dependent on how clean the test setup is. If the input signal is not well isolated on the board, higher noise than specified could be seen at the ADC output.

**表 5-33. Electrical Characteristics for ADC at 1 Msps (continued)**
 $V_{REF+} = 3.3\text{ V}$ ,  $f_{ADC} = 16\text{ MHz}$  (unless otherwise noted)<sup>(1)</sup>

PARAMETER		MIN	TYP	MAX	UNIT
$E_{TSENS}$	Temperature sensor accuracy <sup>(24)</sup> at: –40°C to 105°C ambient (extended temperature part)			±5	°C

(24) This parameter does not include ADC error.

表 5-34 lists the electrical characteristics for the ADC at 2 Msps.

表 5-34. Electrical Characteristics for ADC at 2 Msps

$V_{REF+} = 3.3\text{ V}$ ,  $f_{ADC} = 32\text{ MHz}$ , over operating free-air temperature (unless otherwise noted) (see 图 5-26 and 图 5-27)<sup>(1)</sup>

PARAMETER		MIN	TYP	MAX	UNIT
<b>Power supply requirements</b>					
$V_{DDA}$	ADC supply voltage	2.97	3.3	3.63	V
$G_{NDA}$	ADC ground voltage		0		V
<b>VDDA and GNDA voltage reference</b>					
$C_{REF}$	Voltage reference decoupling capacitance	1.0 // 0.01 <sup>(2)</sup>			$\mu\text{F}$
<b>External voltage reference input</b>					
$V_{REFA+}$	Positive external voltage reference for ADC, when VREF field in the ADCCTL register is 0x1 <sup>(3)</sup>	2.4	$V_{DDA}$	$V_{DDA}$	V
$V_{REFA-}$	Negative external voltage reference for ADC, when VREF field in the ADCCTL register is 0x1 <sup>(3)</sup>	$G_{NDA}$	$G_{NDA}$	0.3	V
$I_{VREF}$	Current on VREF+ input, using external $V_{REF+} = 3.3\text{ V}$		330.5	440	$\mu\text{A}$
$I_{LVREF}$	DC leakage current on VREF+ input when external VREF disabled			2.0	$\mu\text{A}$
$C_{REF}$	External reference decoupling capacitance <sup>(3)</sup>	1.0 // 0.01 <sup>(2)</sup>			$\mu\text{F}$
<b>Analog input</b>					
$V_{ADCIN}$	Single-ended, full-scale analog input voltage, internal reference <sup>(4)(5)</sup>	0		$V_{DDA}$	V
	Differential, full-scale analog input voltage, internal reference <sup>(4)(6)</sup>	$-V_{DDA}$		$V_{DDA}$	
	Single-ended, full-scale analog input voltage, external reference <sup>(3)(5)</sup>	$V_{REFA-}$		$V_{REFA+}$	
	Differential, full-scale analog input voltage, external reference <sup>(3)(7)</sup>	$-(V_{REFA+} - V_{REFA-})$		$V_{REFA+} - V_{REFA-}$	
$V_{INCM}$	Input common-mode voltage, differential mode <sup>(8)</sup>			$[(V_{REFA+} + V_{REFA-}) / 2] \pm 0.025$	V
$I_L$	ADC input leakage current <sup>(9)</sup>			2.0	$\mu\text{A}$
$R_{ADC}$	ADC equivalent input resistance <sup>(9)</sup>			2.5	$\text{k}\Omega$
$C_{ADC}$	ADC equivalent input capacitance <sup>(9)</sup>			10	$\text{pF}$
$R_S$	Analog source resistance <sup>(9)</sup>			250	$\Omega$
<b>Sampling dynamics</b>					
$f_{ADC}$	ADC conversion clock frequency <sup>(10)</sup>		32		MHz
$f_{CONV}$	ADC conversion rate			2	Msps
$t_S$	ADC sample time		125		ns
$t_C$	ADC conversion time <sup>(11)</sup>		0.5		$\mu\text{s}$
$t_{LT}$	Latency from trigger to start of conversion		2		ADC clock cycles

- (1) Best design practices suggest placing static or quiet digital I/O signals adjacent to sensitive analog inputs to reduce capacitive coupling and crosstalk. Unexpected results can occur if a switching digital I/O is placed adjacent to an ADC input channel or voltage reference input. In addition, analog signals configured adjacent to ADC input channels or reference inputs must meet the  $R_{ADC}$  equivalent input resistance given in this table and must be band-limited to 100 kHz or lower.
- (2) Two capacitors in parallel. These capacitors should be as close to the die as possible.
- (3) Assumes external filtering network between  $V_{REFA+}$  and  $V_{REFA-}$  as shown in 图 5-26. External reference noise level must be under 12-bit (-74-dB) full scale input, over input bandwidth, measured at  $V_{REFA+} - V_{REFA-}$ .
- (4) Internal reference is connected directly between  $V_{DDA}$  and  $V_{GNDA}$  ( $V_{REFI} = V_{DDA} - V_{GNDA}$ ). In this mode,  $E_O$ ,  $E_G$ ,  $E_T$ , and dynamic specifications are adversely affected due to internal voltage drop and noise on  $V_{DDA}$  and  $G_{NDA}$ . Internal reference voltage is selected when VREF field in the ADCCTL register is 0x0.
- (5)  $V_{ADCIN} = V_{INP} - V_{INN}$
- (6) With signal common-mode voltage as  $V_{DDA} / 2$ .
- (7) With signal common-mode voltage as  $(V_{REF+} + V_{REF-}) / 2$ .
- (8) This parameter is defined as the average of the differential inputs.
- (9) As shown in 图 5-27,  $R_{ADC}$  is the total equivalent resistance in the input line all the way up to the sampling node at the input of the ADC.
- (10) See 表 5-14 for full ADC clock frequency specification.
- (11) ADC conversion time ( $t_C$ ) includes the ADC sample time ( $t_S$ ).

**表 5-34. Electrical Characteristics for ADC at 2 Msps (continued)**
 $V_{REF+} = 3.3\text{ V}$ ,  $f_{ADC} = 32\text{ MHz}$ , over operating free-air temperature (unless otherwise noted) (see 图 5-26 and 图 5-27)<sup>(1)</sup>

PARAMETER		MIN	TYP	MAX	UNIT
<b>System performance when using external reference</b> <sup>(12) (13)</sup>					
N	Resolution		12		bits
INL	Integral nonlinearity error, over full input range		±1.5	±3.0	LSB
DNL	Differential nonlinearity error, over full input range		±0.8	+2.0/–1.0 <sup>(14)</sup>	LSB
E <sub>O</sub>	Offset error		±1.0	±3.0	LSB
E <sub>G</sub>	Gain error <sup>(15)</sup>		±2.0	±3.0	LSB
E <sub>T</sub>	Total unadjusted error, over full input range <sup>(16)</sup>		±2.5	±4.0	LSB
<b>System performance when using internal reference</b>					
N	Resolution		12		bits
INL	Integral nonlinearity error, over full input range		±1.5	±3.0	LSB
DNL	Differential nonlinearity error, over full input range		±0.8	+2.0/–1.0 <sup>(14)</sup>	LSB
E <sub>O</sub>	Offset error		±5.0	±15.0	LSB
E <sub>G</sub>	Gain error <sup>(15)</sup>		±10.0	±30.0	LSB
E <sub>T</sub>	Total unadjusted error, over full input range <sup>(16)</sup>		±10.0	±30.0	LSB
<b>Dynamic characteristics</b> <sup>(17) (18)</sup>					
SNR <sub>D</sub>	Signal-to-noise-ratio, differential input, V <sub>ADCIN</sub> : –20 dB FS, 1 kHz <sup>(19)</sup>	68	72		dB
SDR <sub>D</sub>	Signal-to-distortion ratio, differential input, V <sub>ADCIN</sub> : –3 dB FS, 1 kHz <sup>(19) (20) (21)</sup>	70	75		dB
SNDR <sub>D</sub>	Signal-to-noise+distortion ratio, differential input, V <sub>ADCIN</sub> : –3 dB FS, 1 kHz <sup>(19) (22) (23)</sup>	65	70		dB
SNR <sub>S</sub>	Signal-to-noise-ratio, single-ended input, V <sub>ADCIN</sub> : –20 dB FS, 1 kHz <sup>(24)</sup>	58	65		dB
SDR <sub>S</sub>	Signal-to-distortion ratio, single-ended input, V <sub>ADCIN</sub> : –3 dB FS, 1 kHz <sup>(20) (21)</sup>	68	72		dB
SNDR <sub>S</sub>	Signal-to-noise+distortion ratio, single-ended input, V <sub>ADCIN</sub> : –3 dB FS, 1 kHz <sup>(24) (22) (23)</sup>	58	63		dB

(12) A low-noise environment is assumed to obtain values close to specifications. The board must have good ground isolation between analog and digital grounds, a clean reference voltage is assumed, and input signal must be bandlimited to Nyquist bandwidth. No antialiasing filter is provided internally.

(13) ADC static measurements taken by averaging over several samples. At least 20-sample averaging is assumed to obtain expected typical or maximum specification values.

(14) 12-bit DNL

(15) Gain error is measured at maximum code after compensating for offset. Gain error is equivalent to "Full Scale Error." It can be given in % of slope error, or in LSB, as done here.

(16) Total Unadjusted Error is the maximum error at any one code versus the ideal ADC curve. It includes all other errors (offset error, gain error and INL) at any given ADC code.

(17) A low noise environment is assumed to obtain values close to spec. The board must have good ground isolation between analog and digital grounds and a clean reference voltage. The input signal must be band-limited to Nyquist bandwidth. No antialiasing filter is provided internally.

(18) ADC dynamic characteristics are measured using low-noise board design, with low-noise reference voltage (< –74 dB noise level in signal BW) and low-noise analog supply voltage. Board noise and ground bouncing couple into the ADC and affect dynamic characteristics. Clean external reference must be used to achieve the listed specifications.

(19) Differential signal with correct common-mode voltage, applied between two ADC inputs.

(20) SDR = –THD in dB.

(21) For higher-frequency inputs, expect degradation in SDR.

(22) SNDR = S/(N+D) = SINAD (in dB)

(23) Effective number of bits (ENOB) can be calculated from SNDR: ENOB = (SNDR – 1.76) / 6.02.

(24) Single-ended inputs are more sensitive to board and trace noise than differential inputs; SNR and SNDR measurements on single-ended inputs are highly dependent on how clean the test setup is. If the input signal is not well isolated on the board, higher noise than specified could be seen at the ADC output.

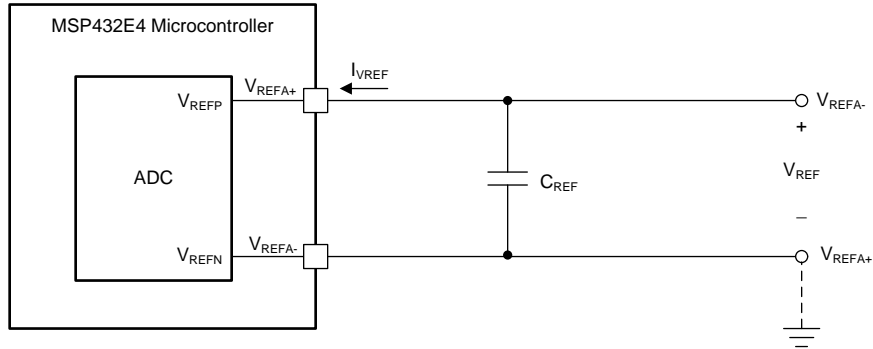

Copyright © 2017, Texas Instruments Incorporated

图 5-26. ADC External Reference Filtering

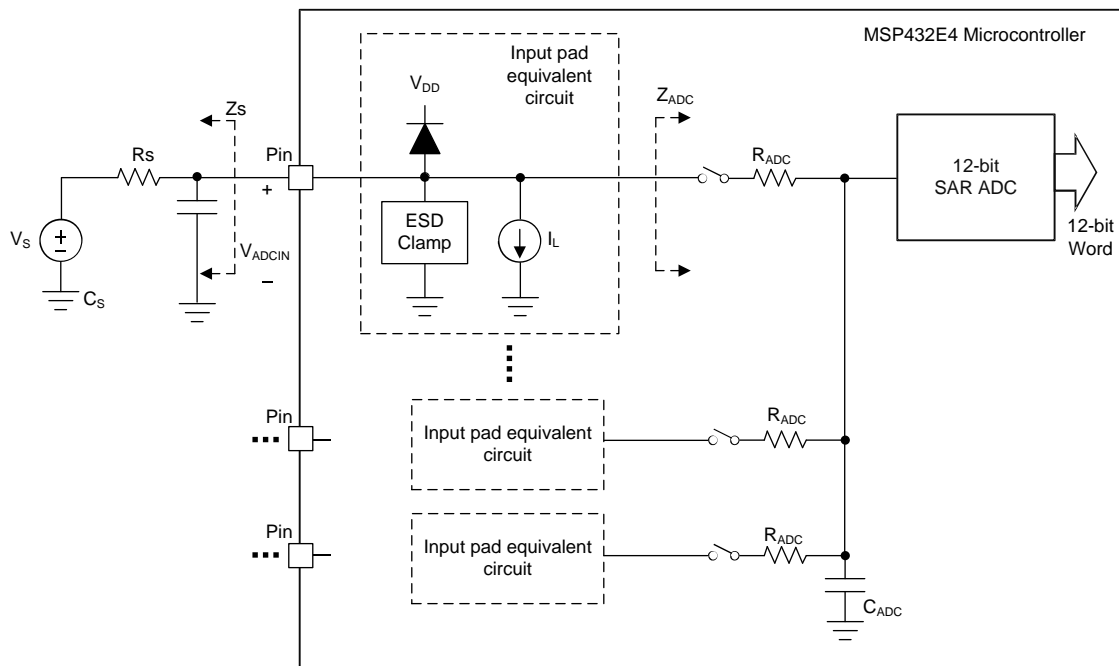

Copyright © 2017, Texas Instruments Incorporated

图 5-27. ADC Input Equivalency



### 5.15.12 Synchronous Serial Interface (SSI)

表 5-35. SSI Characteristics

over operating free-air temperature (unless otherwise noted) (see 图 5-28, 图 5-29, and 图 5-30)

NO.	PARAMETER		MIN	TYP	MAX	UNIT
S1	t <sub>CLK_PER</sub>	SSIClk cycle time	As master <sup>(1)</sup>		16.67	ns
			As slave <sup>(2)</sup>		100	
S2	t <sub>CLK_HIGH</sub>	SSIClk high time	As master		8.33	ns
			As slave		50	
S3	t <sub>CLK_LOW</sub>	SSIClk low time	As master		8.33	ns
			As slave		50	
S4	t <sub>CLKR</sub>	SSIClk rise time <sup>(3)</sup>			1.25	ns
S5	t <sub>CLKF</sub>	SSIClk fall time <sup>(3)</sup>			1.25	ns
S6	t <sub>TXDMOV</sub>	Master mode: master Tx data output (to slave) valid time from edge of SSIClk			4.00	ns
S7	t <sub>TXDMOH</sub>	Master mode: master Tx data output (to slave) hold time after next SSIClk	0.60			ns
S8	t <sub>RXDMS</sub>	Master mode: master Rx data In (from slave) setup time	7.89			ns
S9	t <sub>RXDMH</sub>	Master mode: master Rx data In (from slave) hold time	0			ns
S10	t <sub>TXDSOV</sub>	Slave mode: master Tx data output (to master) valid time from edge of SSIClk			47.60 <sup>(4)</sup>	ns
S11	t <sub>TXDSOH</sub>	Slave mode: slave Tx data output (to master) hold time from next SSIClk	37.4 <sup>(5)</sup>			ns
S13	t <sub>RXDSSU</sub>	Slave mode: Rx data in (from master) setup time	0			ns
S14	t <sub>RXDSSH</sub>	Slave mode: Rx data in (from master) hold time	37.03 <sup>(6)</sup>			ns

- (1) In master mode, the system clock must be at least twice as fast as the SSIClk.
- (2) In slave mode, the system clock must be at least 12 times faster than the SSIClk.
- (3) The delays shown are using 12-mA drive strength.
- (4) This MAX value is for the minimum slave mode t<sub>SYSCLK</sub> period (8.33 ns). To find the MAX t<sub>TXDSOV</sub> value for a larger t<sub>SYSCLK</sub>, use the equation: 4 × t<sub>SYSCLK</sub> + 14.25.
- (5) This MIN value is for the minimum slave mode t<sub>SYSCLK</sub> (8.33 ns). To find the MIN t<sub>TXDSOH</sub> value for a larger t<sub>SYSCLK</sub>, use the equation: 4 × t<sub>SYSCLK</sub> + 4.08.
- (6) This MIN value is for the minimum slave mode t<sub>SYSCLK</sub> (8.33 ns). To find the MIN t<sub>TXDSSH</sub> value for a larger t<sub>SYSCLK</sub>, use the equation: 4 × t<sub>SYSCLK</sub> + 3.70.



图 5-28. SSI Timing for TI Frame Format (FRF = 01), Single Transfer Timing Measurement



图 5-29. Master Mode SSI Timing for SPI Frame Format (FRF = 00), With SPH = 1

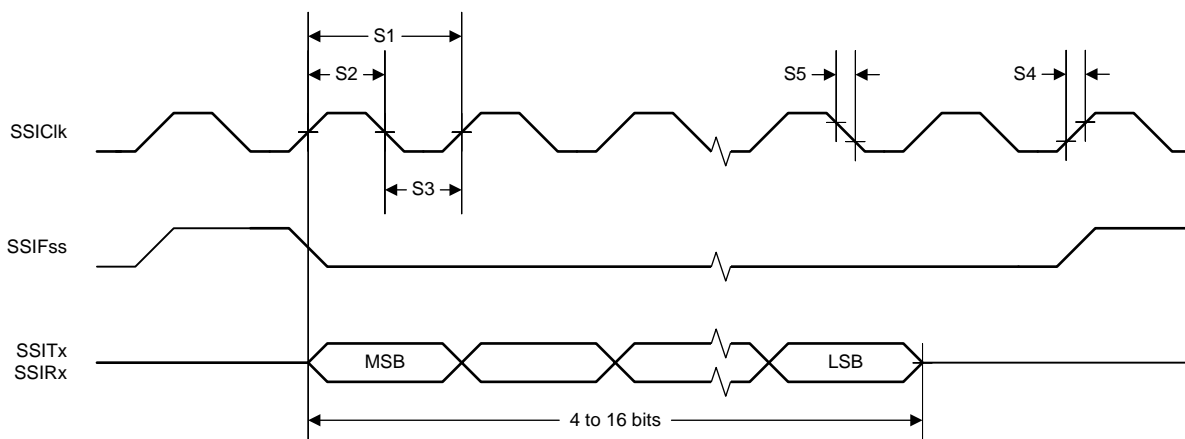

图 5-30. Slave Mode SSI Timing for SPI Frame Format (FRF = 00), With SPH = 1

表 5-36 lists the characteristics for Bi-SSI and Quad-SSI.

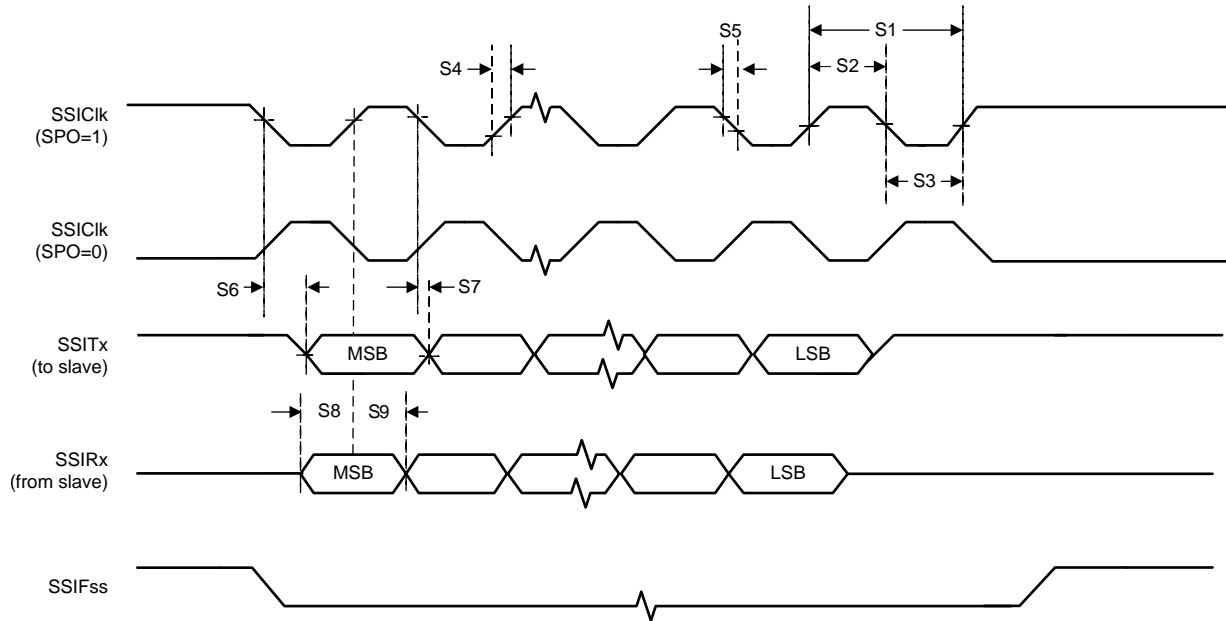
**表 5-36. Bi- and Quad-SSI Characteristics<sup>(1)</sup>**

over operating free-air temperature (unless otherwise noted)

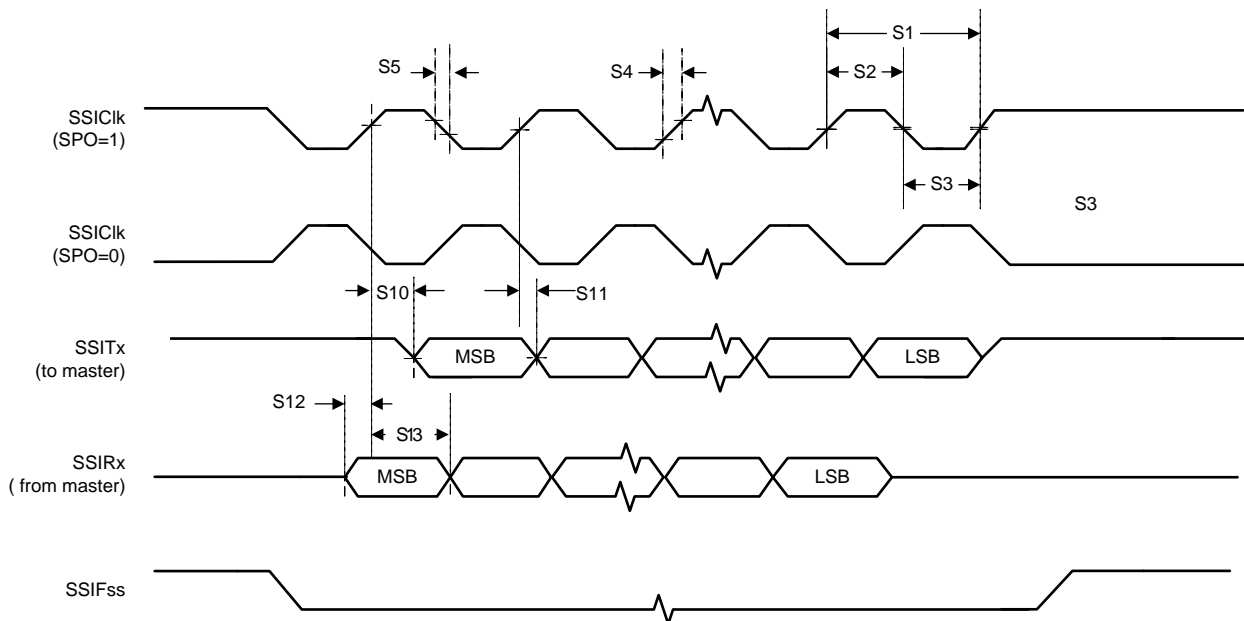
NO.	PARAMETER		MIN	TYP	MAX	UNIT
S15	t <sub>CLK_PER</sub>	SSIClk cycle time, as master <sup>(2)</sup>	16.67			ns
S16	t <sub>CLK_HIGH</sub>	SSIClk high time, as master	8.33			ns
S17	t <sub>CLK_LOW</sub>	SSIClk low time, as master	8.33			ns
S18	t <sub>CLKR</sub>	SSIClk rise time <sup>(3)</sup>	1.25			ns
S19	t <sub>CLKF</sub>	SSIClk fall time <sup>(3)</sup>	1.25			ns
S20	t <sub>TXDMOV</sub>	Master mode: master SSInXDATn data output (to slave) valid time from edge of SSIClk			4.04	ns
S21	t <sub>TXDMOH</sub>	Master mode: master SSInXDATn data output (to slave) hold time after next SSIClk	0.60			ns
S22	t <sub>RXDMS</sub>	Master mode: master SSInXDATn data in (from slave) setup time	5.78			ns
S23	t <sub>RXDMH</sub>	Master mode: master SSInXDATn data in (from slave) hold time	0			ns

(1) Parameters S15 to S23 correspond to parameters S1 to S9 in 图 5-28 and 图 5-29.

(2) In master mode, the system clock must be at least twice as fast as the SSIClk.

(3) The delays shown are using 12-mA drive strength.

### 5.15.13 Inter-Integrated Circuit (I<sup>2</sup>C) Interface

表 5-37 lists the characteristics for the I<sup>2</sup>C interface.

表 5-37. I<sup>2</sup>C Characteristics

over operating free-air temperature (unless otherwise noted) (see 图 5-31)

NO.	PARAMETER		MIN	TYP	MAX	UNIT
I1 <sup>(1)</sup>	t <sub>SCH</sub>	Start condition hold time	36			system clock cycles
I2 <sup>(1)</sup>	t <sub>LP</sub>	Clock low period	36			system clock cycles
I3 <sup>(2)</sup>	t <sub>SRT</sub>	I2CSCL and I2CSDA rise time (V <sub>IL</sub> = 0.5 V to V <sub>IH</sub> = 2.4 V)			See <sup>(2)</sup>	ns
I4	t <sub>DH</sub>	Slave		2		system clock cycles
		Master		7		
I5 <sup>(3)</sup>	t <sub>SFT</sub>	I2CSCL and I2CSDA fall time (V <sub>IH</sub> = 2.4 V to V <sub>IL</sub> = 0.5 V)		9	10	ns
I6 <sup>(1)</sup>	t <sub>HT</sub>	Clock high time	24			system clock cycles
I7	t <sub>DS</sub>	Data setup time	18			system clock cycles
I8 <sup>(1)</sup>	t <sub>CSR</sub>	Start condition setup time (for repeated start condition only)	36			system clock cycles
I9 <sup>(1)</sup>	t <sub>SCS</sub>	Stop condition setup time	24			system clock cycles
I10	t <sub>DV</sub>	Slave		2		system clock cycles
		Master		(6 × (1 + TPR)) + 1		system clock cycles

- (1) Values depend on the value programmed into the TPR bit in the I<sup>2</sup>C Master Timer Period (I2CMTPR) register; a TPR programmed for the maximum I2CSCL frequency (TPR = 0x2) results in a minimum output timing listed in this table. The I<sup>2</sup>C interface is designed to scale the actual data transition time to move it to the middle of the I2CSCL low period. The actual position is affected by the value programmed into the TPR; however, the values in this table are minimum values.
- (2) Because I2CSCL and I2CSDA operate as open-drain-type signals, which the controller can only actively drive low, the time I2CSCL or I2CSDA takes to reach a high level depends on external signal capacitance and pullup resistor values.
- (3) Specified at a nominal 50-pF load



图 5-31. I<sup>2</sup>C Timing

## 5.15.14 Ethernet Controller

### 5.15.14.1 DC Characteristics

The parameters listed in 表 5-38, with the exception of  $R_{BIAS}$ , apply to transmit pins of the Ethernet PHY, which are generally the EN0TXOP and EN0TXON signals during standard operation but can also be the EN0RXIN and EN0RXIP signals if Auto-MDIX is enabled.

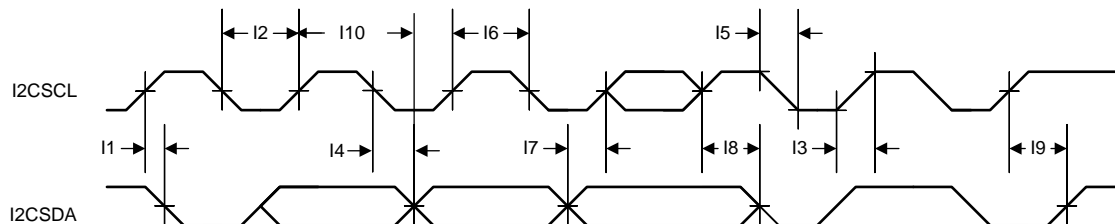
表 5-38. Ethernet PHY DC Characteristics

over operating free-air temperature (unless otherwise noted)

PARAMETER		MIN	TYP	MAX	UNIT
$R_{BIAS}$	Value of the pulldown resistor on the RBIAS pin	4.82	4.87	4.92	k $\Omega$
$V_{TPTD\_100}$	100M transmit voltage	0.95	1	1.05	V
$V_{TPTDSYM}$	100M transmit voltage symmetry	-2%		2%	
$V_{OVRSH}$	Output overshoot			5%	
$V_{TPTD\_10}$	10M transmit voltage	2.2	2.5	2.8	V
$V_{TH1}$	10Base-T Receive threshold		200		mV

### 5.15.14.2 Clock Characteristics for Ethernet

表 5-39 lists the specifications of the MOSC 25-MHz crystal.

表 5-39. MOSC 25-MHz Crystal Specification<sup>(1)</sup>

over operating free-air temperature (unless otherwise noted) (see 图 5-32)

NO.	PARAMETER	MIN	TYP	MAX	UNIT
N1	$f_{MOSC25}$ Frequency		25		MHz
	$f_{TOL}$ Frequency tolerance at operational temperature	0		$\pm 50$	ppm
	$f_{STA}$ Frequency stability at 1-year aging			$\pm 5$	ppm

(1) See 表 5-12 for additional MOSC requirements.



图 5-32. MOSC Crystal Characteristics for Ethernet

表 5-40 lists the specifications of the single-ended 25-MHz oscillator.

**表 5-40. MOSC Single-Ended 25-MHz Oscillator Specification <sup>(1)</sup>**

over operating free-air temperature (unless otherwise noted) (see 图 5-33)

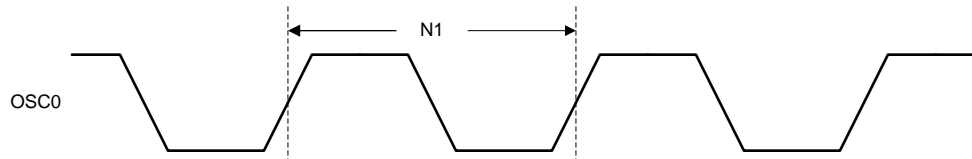
NO.	PARAMETER		MIN	TYP	MAX	UNIT
N4	f <sub>OSC</sub>	Frequency		25		MHz
	f <sub>TOL</sub>	Frequency tolerance at operational temperature	0		±50	ppm
	t <sub>STA</sub>	Frequency stability at 1-year aging			±50	ppm
N5	t <sub>RF</sub>	Frequency rise and fall time			1	ns
	t <sub>J</sub>	Jitter	Cycle to cycle		50	ps
			Over 10 ms		1	ns
DC	Duty cycle	40%		60%		

(1) See 表 5-12 for additional MOSC requirements.

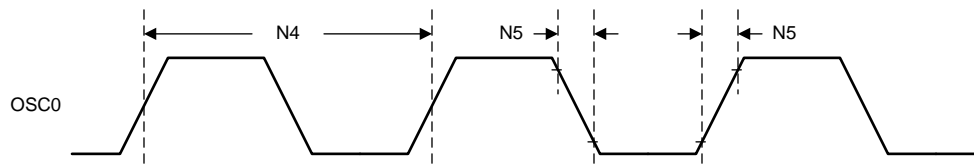

**图 5-33. Single-Ended MOSC Characteristics for Ethernet**

表 5-41 lists the specifications of the EN0RREF\_CLK 50-MHz oscillator.

**表 5-41. EN0RREF\_CLK 50-MHz Oscillator Specification**

over operating free-air temperature (unless otherwise noted) (see 图 5-34)

NO.	PARAMETER		MIN	TYP	MAX	UNIT
N8	f <sub>OSC</sub>	Frequency		50		MHz
	f <sub>TOL</sub>	Frequency tolerance at operational temperature	0		±50	ppm
	t <sub>STA</sub>	Frequency stability at 1-year aging			±50	ppm
N9	t <sub>RF</sub>	Frequency rise and fall time			1.5	ns
	t <sub>J</sub>	Jitter	Cycle to cycle		50	ps
			Over 10 ms		1	ns
DC	Duty cycle	40%		60%		

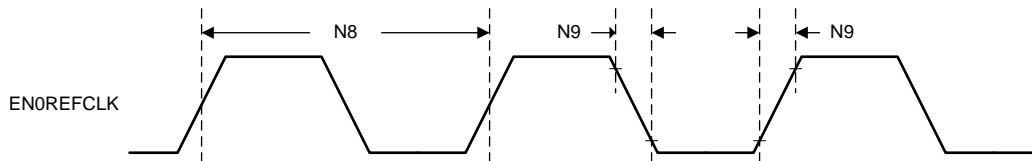

**图 5-34. EN0RREF\_CLK 50-MHz Oscillator Characteristics**

5.15.14.3 AC Characteristics

表 5-42 lists the timing characterists of the enable and reset.

表 5-42. Ethernet Controller Enable and Software Reset Timing

over operating free-air temperature (unless otherwise noted) (see 图 5-35)

NO.	PARAMETER	MIN	TYP	MAX	UNIT
N16	t <sub>EN</sub> Time from the System Control enable of the PHY to energy on the PMD output pin <sup>(1) (2)</sup>	45			μs
N17	t <sub>SWRST</sub> Time from software reset of the PHY to energy on the PMD output pin	110			ns

- (1) The PHY is enabled through System Control by setting the P0 bit in the PCEPHY register and the R0 bit in the RCGCPHY register.
- (2) This minimum timing assumes the PHYHOLD bit in the EMACPC register is not set.



图 5-35. Reset Timing

表 5-43 lists the MII serial management timing.

表 5-43. MII Serial Management Timing

over operating free-air temperature (unless otherwise noted) (see 图 5-36)

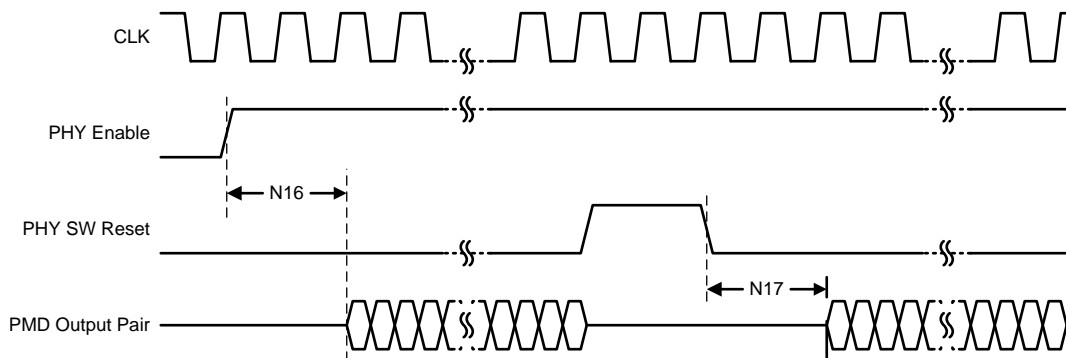
NO.	PARAMETER	MIN	TYP	MAX	UNIT
N20	f <sub>MDC</sub> EN0MDC frequency			2.5	MHz
N21	t <sub>MUDIO_DLY</sub> EN0MDC to EN0MDIO (output) delay time	0	See <sup>(1)</sup>		ns
N22	t <sub>MUDIO_SU</sub> EN0MDIO (input) to EN0MDC setup time	10			ns
N23	t <sub>MUDIO_HLD</sub> EN0MDIO (input) to EN0MDC hold time	10			ns

- (1)  $[1 / (2 \times f_{MDC})] + 1$  system clock period + 10 ns



图 5-36. Station Management Write and Read Timing

表 5-44 lists the 100-Mbps MII transmit timing.

**表 5-44. 100-Mbps MII Transmit Timing**

over operating free-air temperature (unless otherwise noted) (see 图 5-37)

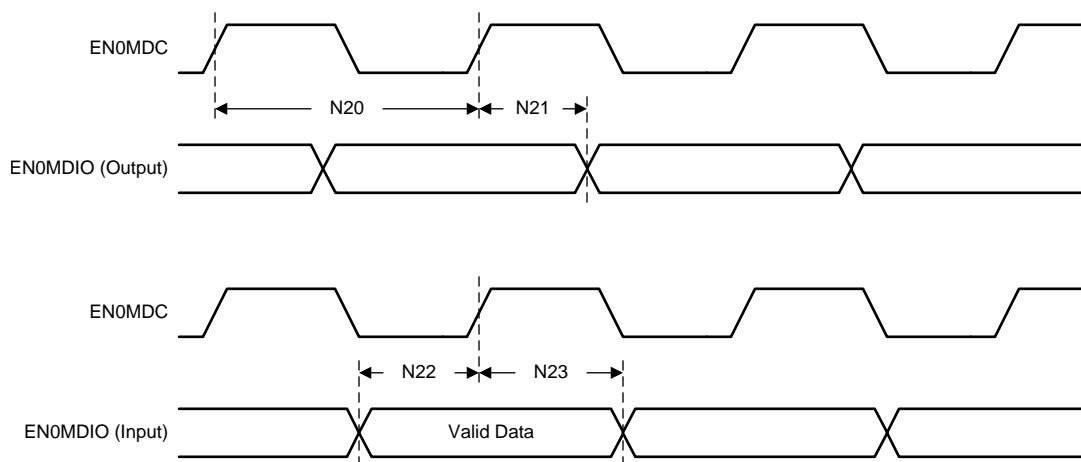
NO.	PARAMETER		MIN	TYP	MAX	UNIT
N26	t <sub>TXCK_HI</sub>	EN0TXCK high time	16	20	24	ns
N27	t <sub>TXCK_LO</sub>	EN0TXCK low time	16	20	24	ns
N28	t <sub>TX_DLY</sub>	EN0TXCK to EN0TXDn, EN0TXEN delay	0		25	ns

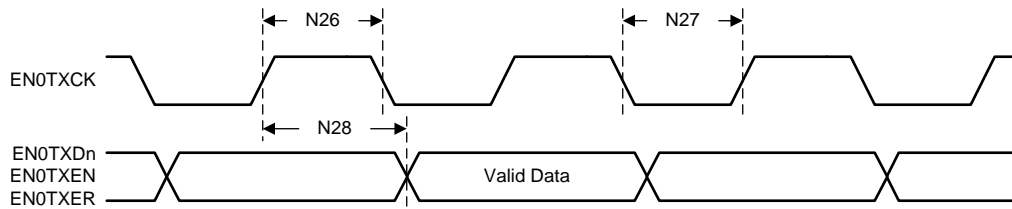

**图 5-37. 100-Mbps MII Transmit Timing**

表 5-45 lists the 100-Mbps MII receive timing.

**表 5-45. 100-Mbps MII Receive Timing**

over operating free-air temperature (unless otherwise noted) (see 图 5-38)

NO.	PARAMETER		MIN	TYP	MAX	UNIT
N30	t <sub>RXCK_HI</sub>	EN0RXCK high time	16	20	24	ns
N31	t <sub>RXCK_LO</sub>	EN0RXCK low time	16	20	24	ns
N32	t <sub>RXCK_SU</sub>	EN0RXDn, EN0RXDV, EN0RXER data setup to EN0RXCK	10			ns
N33	t <sub>RXCK_HLD</sub>	EN0RXDn, EN0RXDV, EN0RXER data hold to EN0RXCK	0			ns

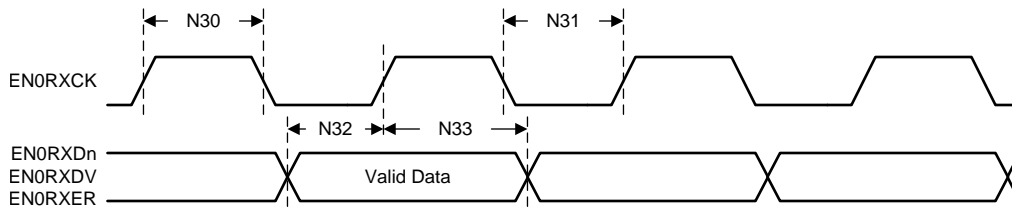

**图 5-38. 100-Mbps MII Receive Timing**



表 5-46 lists the 100Base-TX transmit timing.

表 5-46. 100Base-TX Transmit Timing

over operating free-air temperature (unless otherwise noted) (see 图 5-39)

NO.	PARAMETER	MIN	TYP	MAX	UNIT
N38	$t_{RF}$ 100-Mbps PMD output pair $t_R$ and $t_F$ <sup>(1)</sup>	3	4	5	ns
	$t_{RF\_MM}$ 100-Mbps $t_R$ and $t_F$ symmetry <sup>(2) (3)</sup>			500	ps
N39	$t_{RF\_JTTR}$ 100-Mbps PMD output pair transmit jitter			1.4	ns

- (1) Rise and fall times taken at 10% and 90% of the +1 or -1 amplitude.
- (2) Normal mismatch is the difference between the maximum and minimum of all rise and fall times
- (3) Choice of Ethernet transformer magnetics can affect this parameter.



图 5-39. 100 Base-TX Transmit Timing

表 5-47 lists the 10-Mbps MII transmit timing.

表 5-47. 10-Mbps MII Transmit Timing

over operating free-air temperature (unless otherwise noted) (see 图 5-40)

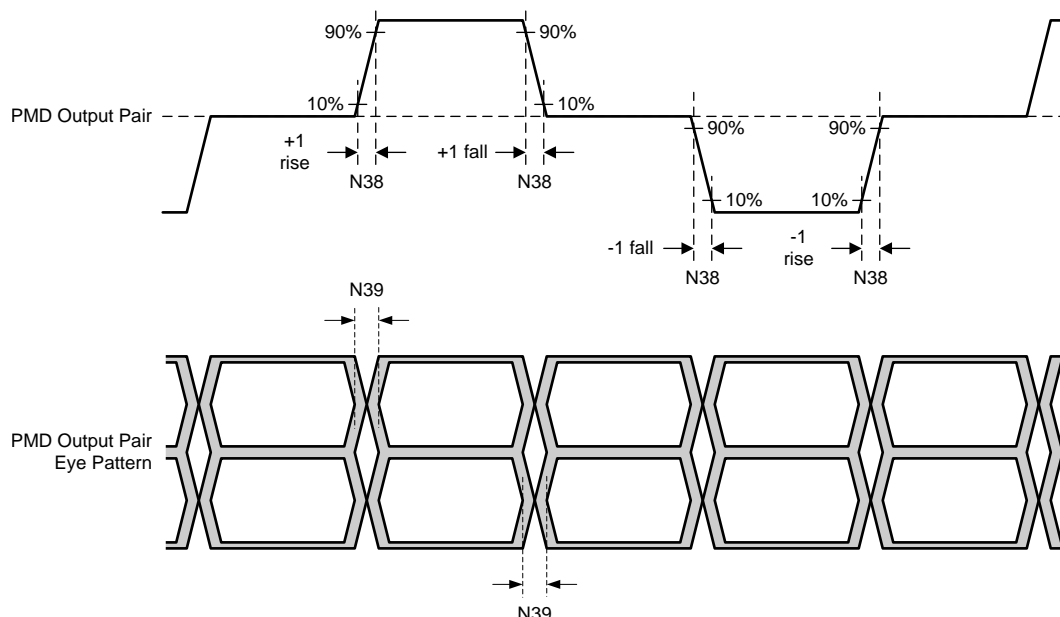
NO.	PARAMETER	MIN	TYP	MAX	UNIT
N45	$t_{TXCK\_HI}$ EN0TXCK high time	190	200	210	ns
N46	$t_{TXCK\_LO}$ EN0TXCK low time	190	200	210	ns
N47	$t_{TX\_DLY}$ EN0TXCK to EN0TXDn, EN0TXEN delay	0		25	ns



图 5-40. 10-Mbps MII Transmit Timing

表 5-48 lists the 10-Mbps MII receive timing.

**表 5-48. 10-Mbps MII Receive Timing**

over operating free-air temperature (unless otherwise noted) (see 图 5-41)

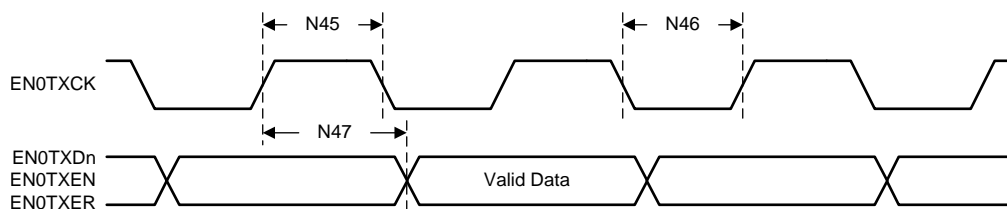
NO.	PARAMETER		MIN	TYP	MAX	UNIT
N50	$t_{RXCK\_HI}$	EN0RXCK high time	160	200	240	ns
N51	$t_{RXCK\_LO}$	EN0RXCK low time	160	200	240	ns
N52	$t_{RX\_SU}$	EN0RXCK to EN0RXDn, EN0RXDV, EN0RXER setup	100			ns
N53	$t_{RX\_HLD}$	EN0RXCK to EN0RXDn, EN0RXDV, EN0RXER hold	100			ns

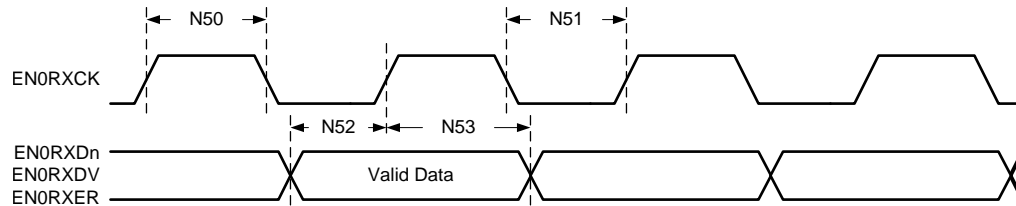

**图 5-41. 10-Mbps MII Receive Timing**

表 5-49 lists the 10Base-T normal link pulse timing.

**表 5-49. 10Base-T Normal Link Pulse Timing**

over operating free-air temperature (unless otherwise noted) (see 图 5-42)

NO.	PARAMETER		MIN	TYP	MAX	UNIT
N69	$t_{LP\_PER}$	Link pulse period		76		ms
N70	$t_{LP\_WID}$	Link pulse width		100		$\mu$ s

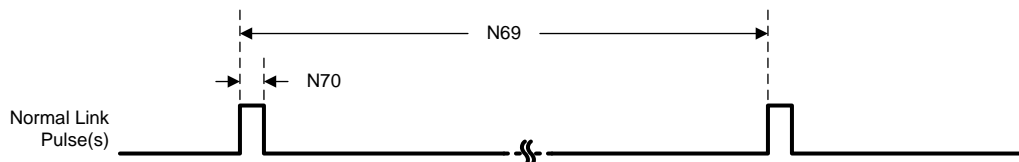

**图 5-42. 10Base-TX Normal Link Pulse Timing**

表 5-50 lists the Auto-Negotiation FLP timing.

表 5-50. Auto-Negotiation Fast Link Pulse (FLP) Timing

over operating free-air temperature (unless otherwise noted) (see 图 5-43)

NO.	PARAMETER		MIN	TYP	MAX	UNIT
N72	$t_{CLKP}$	Clock pulse to clock pulse period		125		$\mu s$
N73	$t_{CLKDP}$	Clock pulse to data pulse period		62		$\mu s$
N74	$t_{PUL}$	Clock, data pulse width		110		ns
N75	$t_{BRSTP}$	FLP burst to flp burst period		16		ms
N76	$t_{BRSTW}$	Burst width		2		ms



图 5-43. Auto-Negotiation Fast Link Pulse Timing

表 5-51 lists the 100Base-TX signal detect timing.

表 5-51. 100Base-TX Signal Detect Timing

over operating free-air temperature (unless otherwise noted) (see 图 5-44)

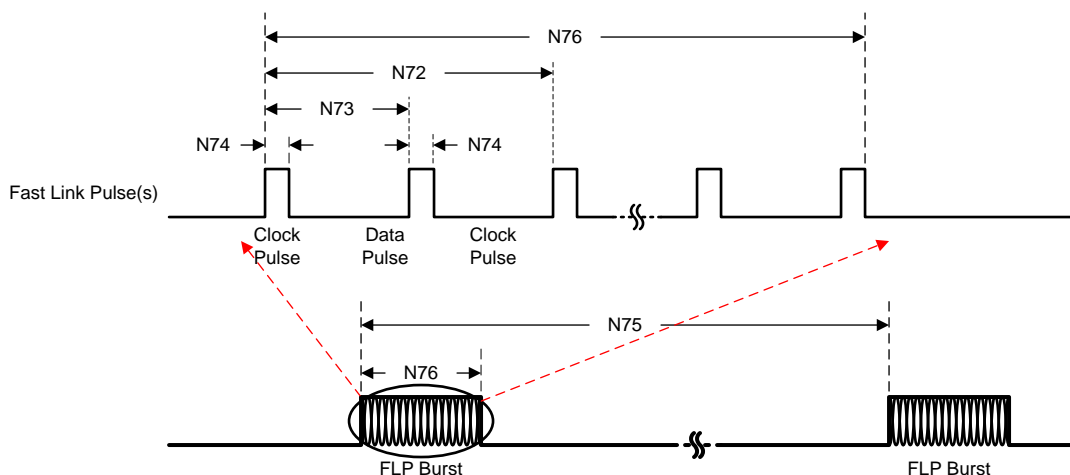
NO.	PARAMETER		MIN	TYP	MAX	UNIT
N79	$t_{ON}$	SD internal turnon time			100	$\mu s$
N80	$t_{OFF}$	Internal turnoff time			200	$\mu s$



图 5-44. 100Base-TX Signal Detect Timing

表 5-52 lists the RMI transmit timing.

表 5-52. RMI Transmit Timing

over operating free-air temperature (unless otherwise noted) (see 图 5-45)

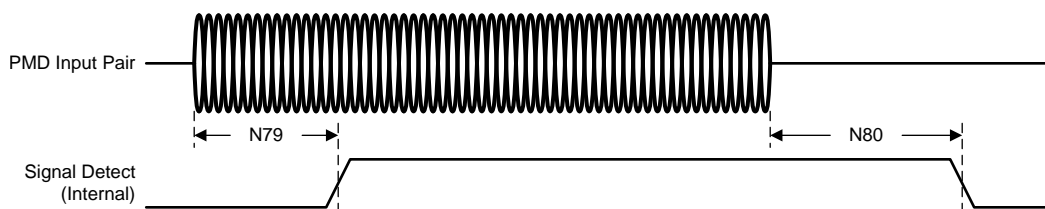
NO.	PARAMETER		MIN	TYP	MAX	UNIT
N86	$f_{REFCLK}$	EN0RREF_CLK frequency		50		MHz
	$DC_{REFCLK}$	EN0RREF_CLK duty cycle	40%		60%	
N87	$t_{TX\_DLY}$	EN0RREF_CLK to EN0TXDn, EN0TXEN delay	2		14	ns



图 5-45. RMI Transmit Timing

表 5-53 lists the RMI receive timing.

表 5-53. RMI Receive Timing

over operating free-air temperature (unless otherwise noted) (see 图 5-46)

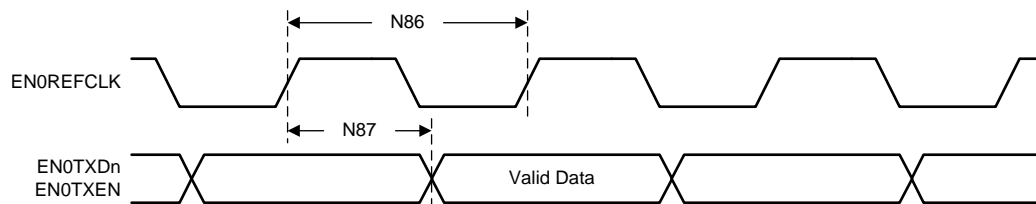
NO.	PARAMETER		MIN	TYP	MAX	UNIT
N91	$f_{REFCLK}$	EN0RREF_CLK frequency		50		MHz
	$DC_{REFCLK}$	EN0RREF_CLK duty cycle	40%		60%	
N92	$t_{RX\_SU}$	EN0RXDn, EN0RXEN, EN0CRS setup time to EN0RREF_CLK	4			ns
N93	$t_{RX\_HLD}$	EN0RXDn, EN0RXEN, EN0CRS hold time from EN0RREF_CLK	2			ns



图 5-46. RMI Receive Timing

### 5.15.15 Universal Serial Bus (USB) Controller

The USB controller electrical specifications are compliant with the Universal Serial Bus Specification Rev 2.0 (full-speed and low-speed support) and the On-The-Go Supplement to the USB 2.0 Specification Rev 1.0. Some components of the USB system are integrated within the microcontroller and specific to the microcontroller design.

注

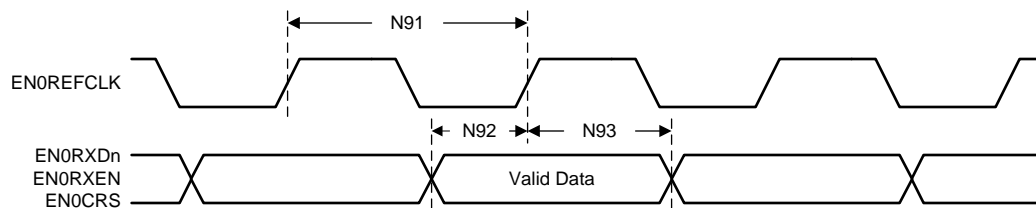
GPIO pin PB1, which can be configured as the USB0VBUS signal, is the only pin that is 5-V tolerant on the device.

表 5-54 lists the timing characteristics of the ULPI interface.

表 5-54. ULPI Interface Timing

over operating free-air temperature (unless otherwise noted) (see 图 5-47)

NO.	PARAMETER		MIN	TYP	MAX	UNIT
<b>Timings with respect to external clock source input to USB0CLK</b>						
U1	$t_{SUC}$	Setup time (control in) USB0DIR, USB0NXT	4.8			ns
U2	$t_{SUD}$	Setup time (data in) USB0Dn	3.5			ns
U3	$t_{HTC}$	Hold time (control in) USB0DIR, USB0NXT	0			ns
U4	$t_{HTD}$	Hold time (data in) USB0Dn	0			ns
U5	$t_{ODC}$	Output delay (control out) USB0STP	3.7		9.5	ns
U6	$t_{ODD}$	Output delay (data out) USB0Dn	3.7		9.5	ns
<b>Timings with USB0CLK as clock output</b>						
U1	$t_{SUC}$	Setup time (control in) USB0DIR, USB0NXT	6.0			ns
U2	$t_{SUD}$	Setup time (data in) USB0Dn	4.6			ns
U3	$t_{HTC}$	Hold time (control in) USB0DIR, USB0NXT	0			ns
U4	$t_{HTD}$	Hold time (data in) USB0Dn	0			ns
U5	$t_{ODC}$	Output delay (control out) USB0STP	4.0		10.6	ns
U6	$t_{ODD}$	Output delay (data out) USB0Dn	4.0		10.6	ns



图 5-47. ULPI Interface Timing Diagram

### 5.15.16 LCD Controller

The LCD controller consists of two independent controllers, the raster controller and the LCD interface display driver (LIDD) controller. Each controller operates independently from the other and only one of them is active at any given time.

- The LIDD controller supports an asynchronous LCD interface that provides full timing programmability of control signals (CS, WE, OE, ALE) and output data. The LIDD controller also supports synchronous interface in Motorola 6800 mode and Intel 8080 mode through the use of the external LCDMCLK output.
- The raster controller supports the synchronous LCD interface and provides timing and data for constant graphics refresh to a passive display. The raster controller supports a variety of monochrome and full-color display types and sizes by use of programmable timing controls, a built-in palette, and a gray-scale and serializer. Graphics data is processed and stored in frame buffers. A frame buffer is a contiguous memory block in the system. The  $\mu$ DMA supplies the graphics data to the raster engine which, in turn, outputs to the external LCD device.

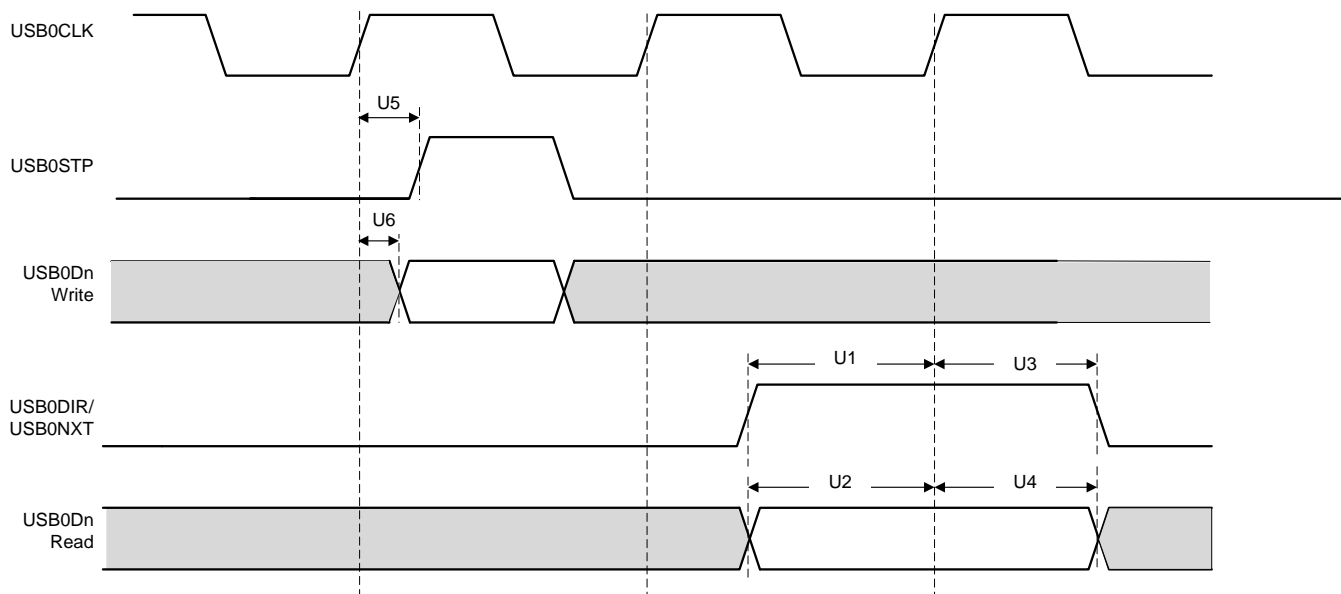
The maximum resolution for the LCD controller is 2048 × 2048 pixels. The maximum frame rate is determined by the image size in combination with the pixel clock rate.

The LCD signals must be configured with a drive strength of 8 mA with slew rate control.

表 5-55 lists the load capacitance limits of the LCD controller.

**表 5-55. LCD Controller Load Capacitance Limits**

over operating free-air temperature (unless otherwise noted)

PARAMETER		TEST CONDITIONS	MIN	TYP	MAX	UNIT
C <sub>LOAD</sub>	LCD output load capacitance	LIDD mode	5		50	pF
		Raster mode	3		30	pF

注

A 25-pF load is assumed for LCD timings.

#### 5.15.16.1 LCD Interface Display Driver (LIDD Mode)

In LIDD mode, the LIDDCS0CFG register allows for full programmability of the read and write strobes, data and enables. In the LCDCS0CFG register, the following parameters can be configured with respect to the internal MCLK:

- WRSU (bits[31:27]): Number of MCLK cycles that the LCDDATA bus, output enable, ADE, DIR, and CS0 signals must be ready before the write strobe. The minimum value is 0x0.
- WRDUR (bits[26:21]): Number of MCLK cycles for which the write strobe is held active when performing a write access. The minimum value is 0x1.
- WRHOLD (bits[20:17]): Number of MCLK cycles for which the LCDDATA bus, output enable, ALE, DIR, and CS0 signals are held after the write strobe is deasserted when performing a write access. The minimum value is 0x1.
- RDSU (bits[16:12]): When performing a read access, this field defines the number of MCLK cycles that the LCDDATA bus, output enable, ALE, DIR, and CS0 signals must be ready before the read strobe is asserted.
- RDDUR (bits[11:6]): Number of MCLK cycles for which the read strobe is held active when performing a read access. The minimum value is 0x1.
- RDHOLD (bits[5:2]): Number of MCLK cycles for which the LCDDATA bus, output enable, ALE, DIR, and CS0 signals are held after the read strobe is deasserted when performing a read access. The minimum value is 0x1.
- GAP (bits[1:0]): Number of MCLK cycles (GAP + 1) between the end of one CS0 device access and the start of another CS0 device access, unless both accesses are reads. In this case, this delay is not incurred. The minimum value is 0x0.

Essentially, output valid/hold and input setup/hold times in LIDD mode are programmed by these fields. In addition, the inherent clock delay from the internal MCLK transition to the signal output adds or subtracts to these programmed times as indicated in the following tables and figures.

表 5-56 lists the LCD switching characteristics.

**表 5-56. LCD Switching Characteristics**

over operating free-air temperature (unless otherwise noted) (see 图 5-48, 图 5-49, 图 5-50, and 图 5-51)

NO.	PARAMETER		MIN	TYP	MAX	UNIT
L1	$t_{CYC}$	Internal MCLK cycle time		50		ns
L2	$t_{CYCH}$	Internal MCLK pulse duration high		25		ns
L3	$t_{CYCL}$	Internal MCLK pulse duration low		25		ns
L4	$t_{DLYVAL}$	Delay time from internal MCLK high to LCDDATA[15:0] valid (write)			11.6	ns
L5	$t_{DLYINV}$	Delay time from internal MCLK high to LCDDATA[15:0] invalid (write)			4.0	ns
L6	$t_{DLYHAC}$	Delay time, internal MCLK high to LCDAC			11.19	ns
L7	$t_{TRANAC}$	LCDAC transition time			5.9	ns
L8	$t_{DLYFP}$	Delay time from internal MCLK high to LCDFP			10.5	ns
L9	$t_{TRANFP}$	LCDFP transition time			5.9	ns
L10	$t_{DLYLP}$	Delay time internal MCLK high to LCDLP			11.0	ns
L11	$t_{TRANLP}$	LCDLP transition time			5.9	ns
L12	$t_{DLYCP}$	Delay time of internal MCLK to LCDCP			8.4	ns
L13	$t_{TRANCP}$	LCDCP transition time			5.9	ns
L14	$t_{DLYDZ}$	Delay time from internal MCLK high to LCDDATA[15:0] Hi-Z (read cycle)			11.7	ns
L15	$t_{DLYDD}$	Delay time from internal MCLK high to LCDDATA[15:0] active (read cycle)			11.0	ns
L19	$t_{TRANMCLK}$	Internal MCLK transition time			5.9	ns
L20	$t_{TRANPKT}$	LCDDATA transition time from one data packet to next			5.9	ns

表 5-57 lists the timing requirements for LCDDATA in LIDD mode.

**表 5-57. Timing Requirements for LCDDATA in LIDD Mode**

over operating free-air temperature (unless otherwise noted) (see 图 5-48, 图 5-49, 图 5-50, and 图 5-51)

NO.	PARAMETER		MIN	TYP	MAX	UNIT
L16	$t_{STDATA}$	LCDDATA[15:0] setup time (read) before internal MCLK high	20			ns
L17	$t_{HTDATA}$	LCDDATA[15:0] hold time (read) after internal MCLK high	0			ns
L18	$t_{TRANRDATA}$	LCDDATA read transition time	5.9			ns

#### 5.15.16.1.1 Hitachi Mode

Hitachi mode is an asynchronous mode that does not use an external LCDMCLK and allows for full programmability of the read and write strobes, data, and enables through the LIDDCS0CFG register. In addition to the parameter delays configured in the LIDDCS0CFG register, the delay times in the following figures that are from the internal MCLK to the signal output must be added to the programmed delays for full timing information. All of the parameter values associated with the following figures can be found in 表 5-56 and 表 5-57.

In 图 5-48, 图 5-49, and 图 5-50 the second LCDMCLK is shown as E1 and can be used as the enable strobe for a second display in Hitachi mode. The primary enable strobe is the LCDAC signal.

#### 注

The acronyms WRSU, WRDUR, WRHOLD, and GAP in the following figures correspond to the bit fields of the LIDDCS0CFG register described in 节 5.15.16.1.



图 5-48. Command Write in Hitachi Mode



图 5-49. Data Write in Hitachi Mode



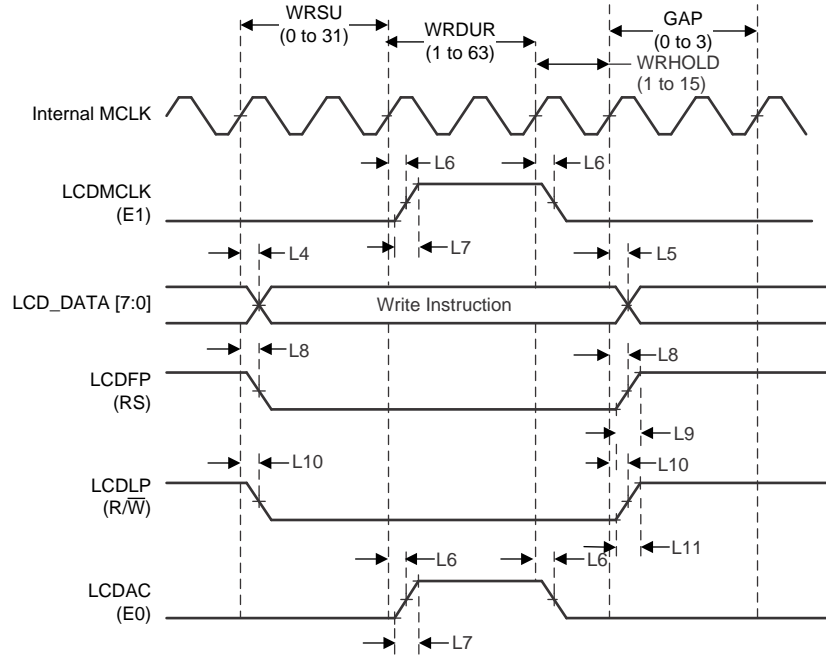

图 5-50. Command Read in Hitachi Mode

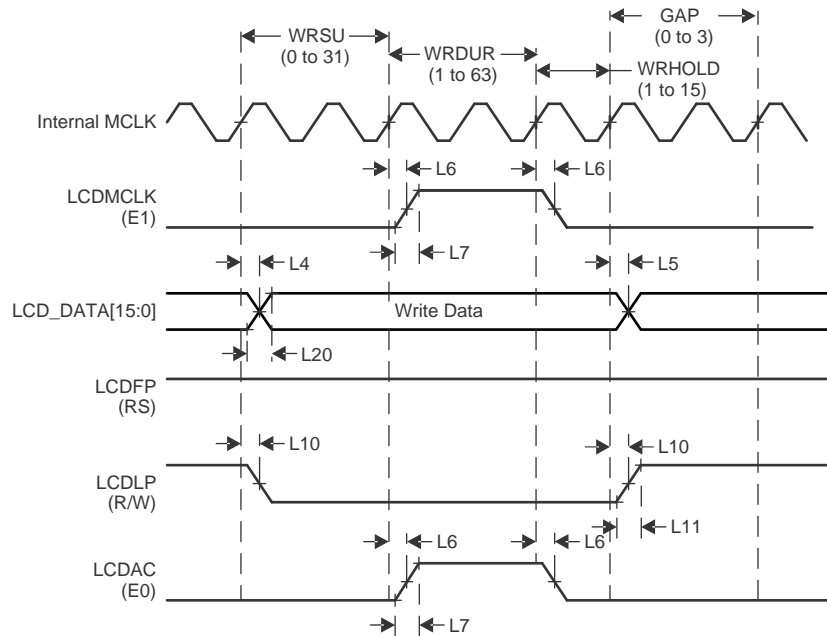

图 5-51. Data Read in Hitachi Mode

5.15.16.1.2 Motorola 6800 Mode

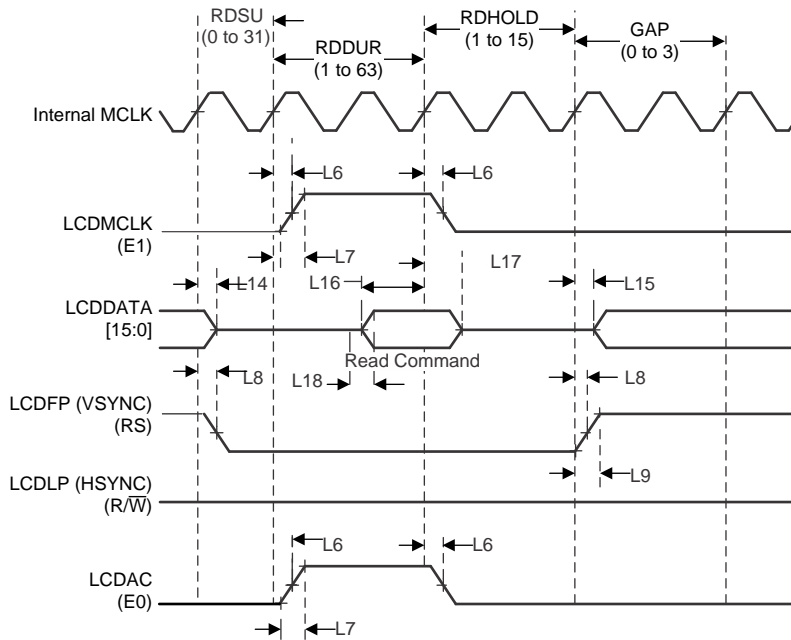
Motorola 6800 mode can be configured to perform asynchronous operations or synchronous operations. When configured in asynchronous mode, LCDMCLK is not required, so it performs the CS1 function. When configured in synchronous mode, MCLK is available externally through the signal LCDMCLK. In asynchronous mode, the internal MCLK shown represents the internal clock that sequences the other signals. All parameter values associated with the following figures can be found in 表 5-56 and 表 5-57.

注

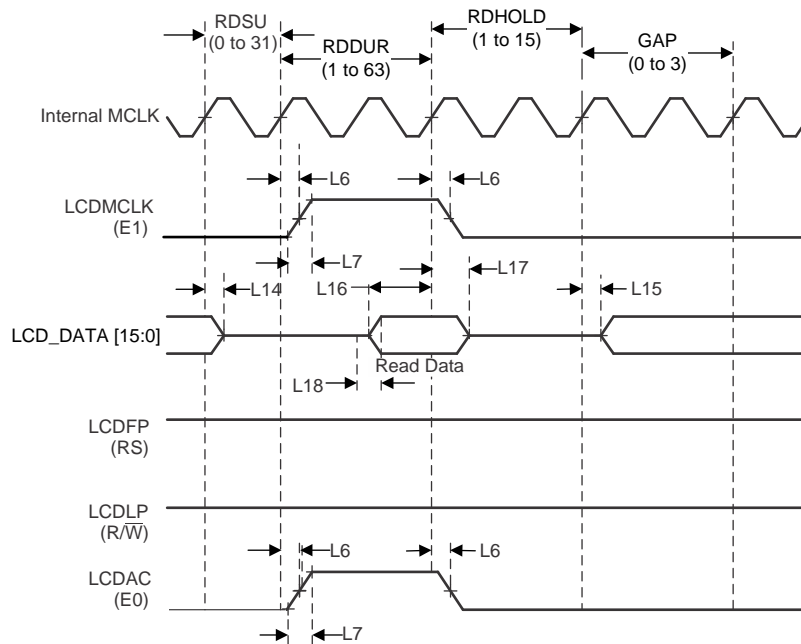
In asynchronous Motorola 6800 mode, LCDCP functions as the read and write strobe.

注

The acronyms WRSU, WRDUR, WRHOLD, GAP, RDHOLD, RDSU, and RDDUR in 图 5-52, 图 5-53, and 图 5-54 correspond to the bit fields of the LIDDCS0CFG register described in 节 5.15.16.1.



图 5-52. Motorola 6800 Graphic Display Mode Write (Synchronous and Asynchronous Operation)



图 5-53. Motorola 6800 Graphic Display Mode Read (Synchronous and Asynchronous Operation)

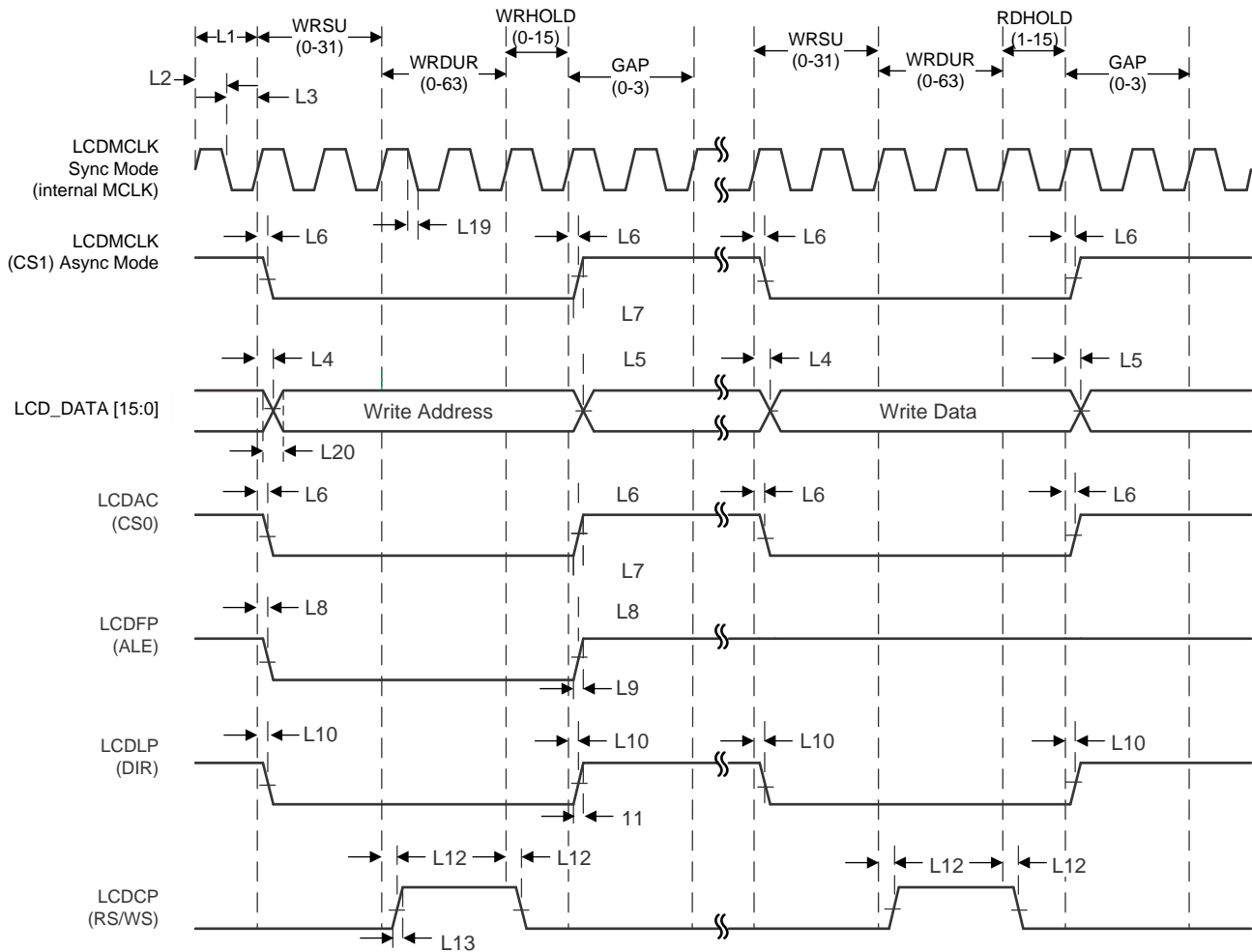

图 5-54. Motorola 6800 Graphic Display Mode Status (Synchronous and Asynchronous Operation)

5.15.16.1.3 Intel 8080 Mode

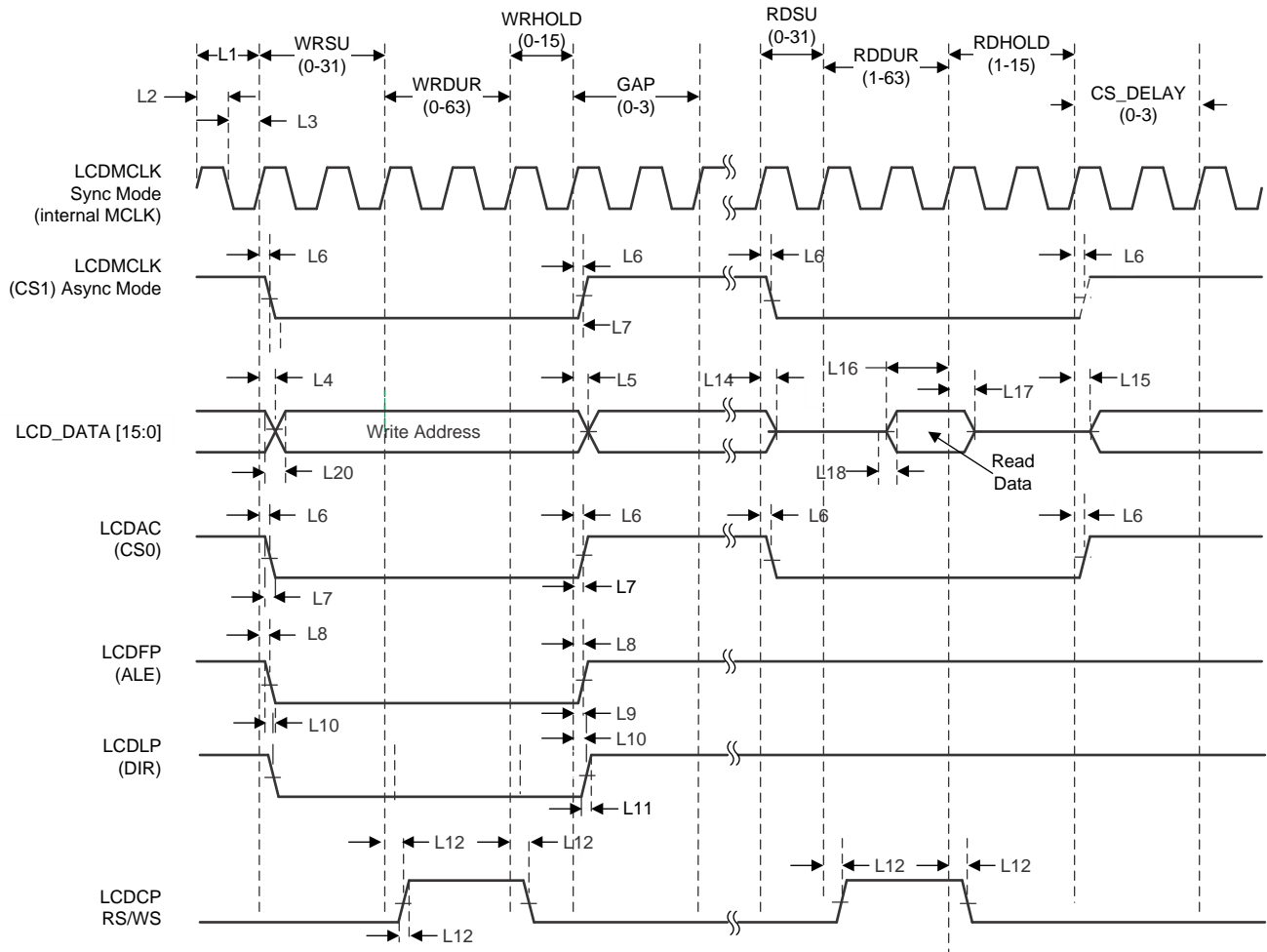
Intel mode can be configured to perform asynchronous operations or synchronous operations. When configured in asynchronous mode, LCDMCLK is not required, so it performs the CS1 function. When configured in synchronous mode, MCLK is available externally through the signal LCDMCLK. In asynchronous mode, the internal MCLK shown represents the internal clock that sequences the other signals. All of the parameter values associated with the following figures can be found in 表 5-56 and 表 5-57.

注

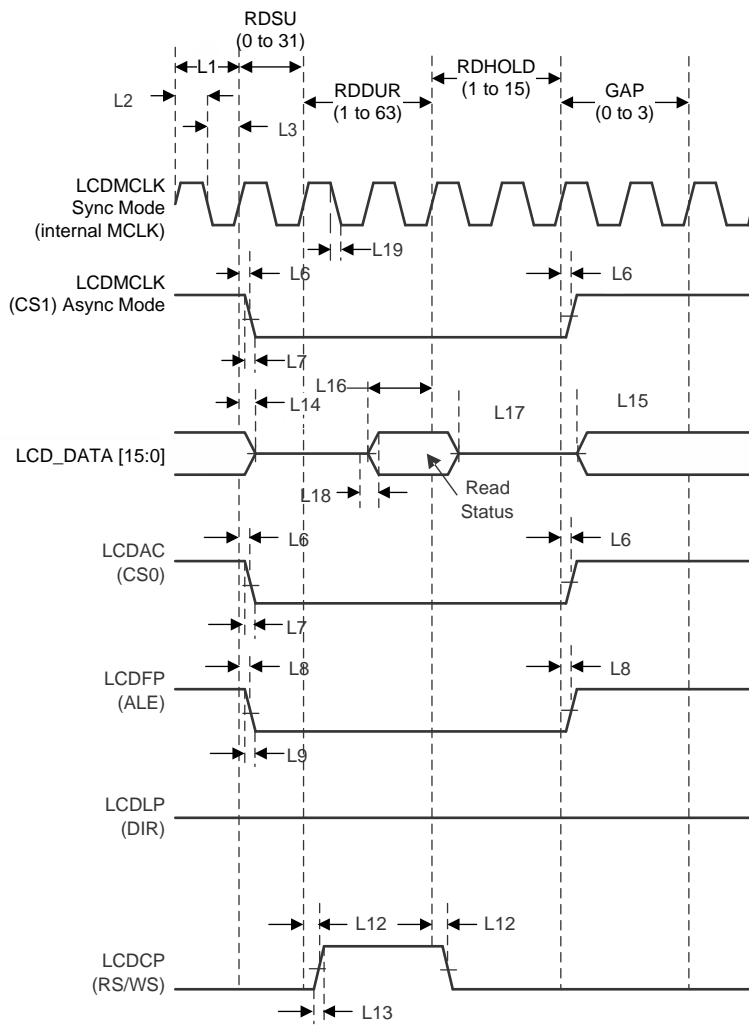
The acronyms WRSU, WRDUR, WRHOLD, GAP, RDHOLD, RDSU, and RDDUR in 图 5-55, 图 5-56, and 图 5-57 correspond to the bit fields of the LIDDCS0CFG register described in 节 5.15.16.1.



图 5-55. Micro-Interface Graphic Display Intel Write



图 5-56. Micro-Interface Graphic Display Intel Read

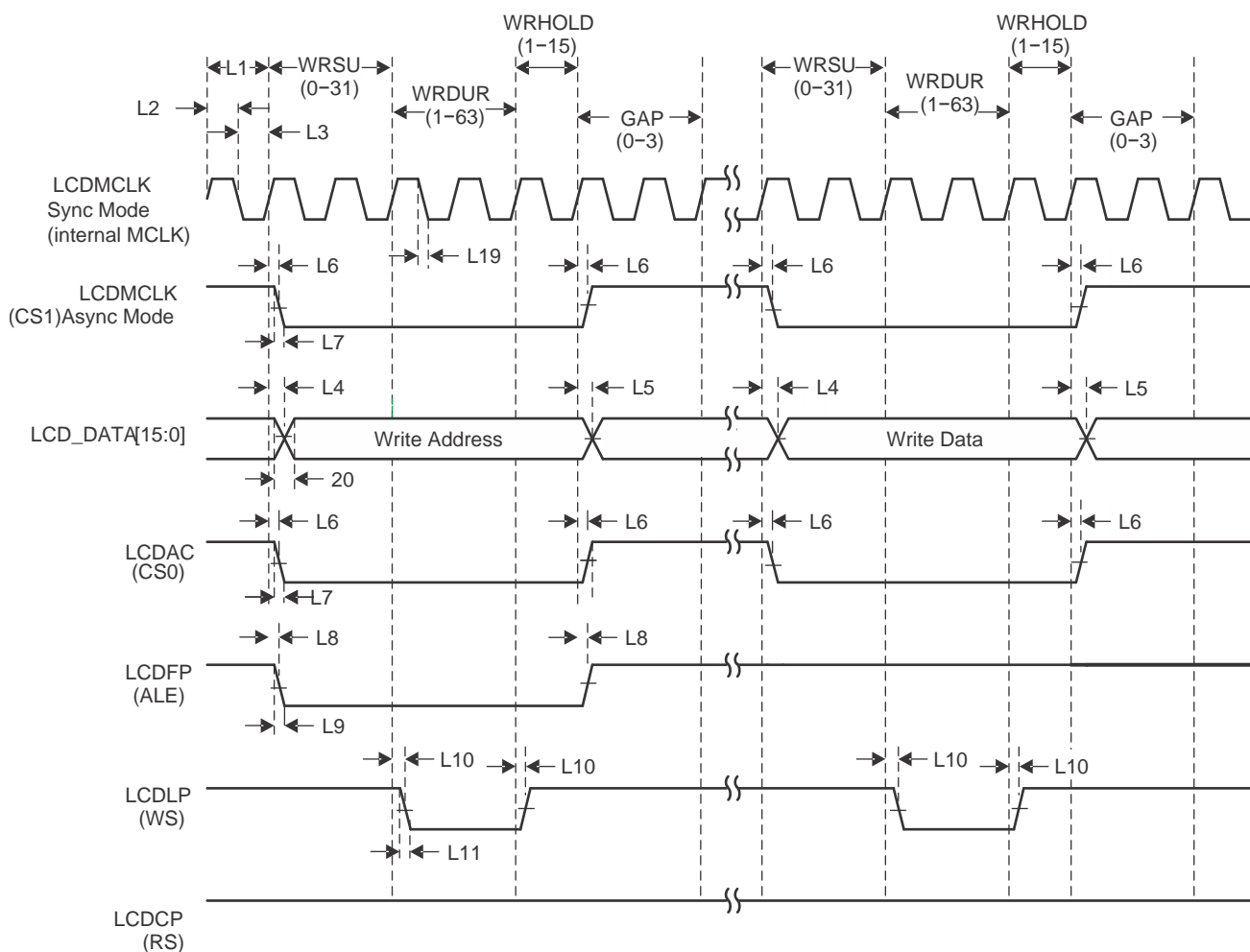

图 5-57. Micro-Interface Graphic Display Intel Status

### 5.15.16.2 LCD Raster Mode

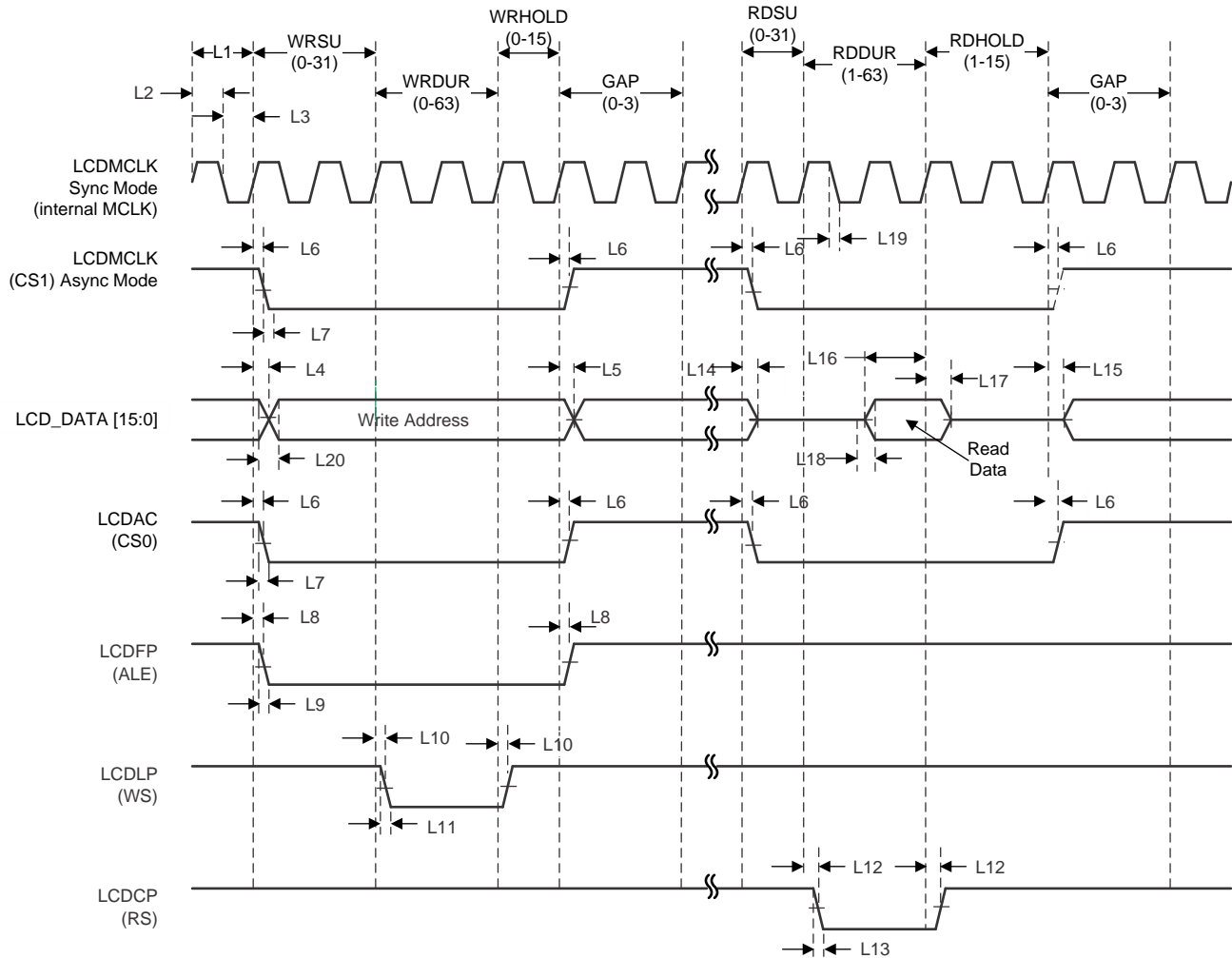
表 5-58 lists the LCD raster mode characteristics.

**表 5-58. Switching Characteristics for LCD Raster Mode**

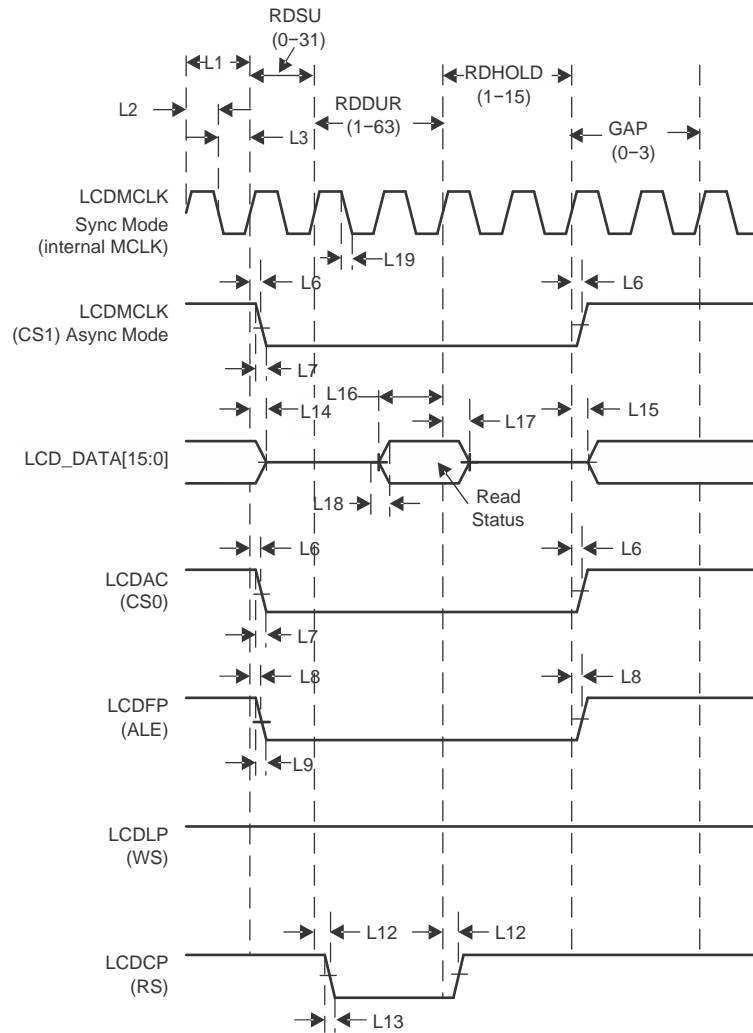
over operating free-air temperature (unless otherwise noted) (see 图 5-58, 图 5-59, 图 5-60, 图 5-61, and 图 5-62)

NO.	PARAMETER		MIN	TYP	MAX	UNIT
L21	t <sub>CYC</sub>	LCDCP cycle time	16.67			ns
L22	t <sub>PH</sub>	LCDCP pulse width high	8.33			ns
L23	t <sub>PL</sub>	LCDCP pulse width low	8.33			ns
L24	t <sub>DLYVAL</sub>	Delay time from LCDCP to LCDDATA[23:0] valid (write)	2.0		7.3	ns
L25	t <sub>DLYINV</sub>	Delay time from LCDCP to LCDDATA[23:0] invalid (write)	2.0		7.3	ns
L26	t <sub>DLYHAC</sub>	Delay time, LCDCP to LCDAC	1.9		7.0	ns
L27	t <sub>TRANAC</sub>	LCDAC transition time	0.5		3.3	ns
L28	t <sub>DLYFP</sub>	Delay time from LCDCP high to LCDFP	1.7		6.5	ns
L29	t <sub>TRANFP</sub>	LCDFP transition time	0.5		3.3	ns
L30	t <sub>DLYLP</sub>	Delay time from LCDCP high to LCDLP	2.0		6.8	ns
L31	t <sub>TRANLP</sub>	LCDLP transition time	0.5		3.3	ns
L32	t <sub>TRANCP</sub>	LCDCP transition time	0.5		3.3	ns
L33	t <sub>TRANDATA</sub>	LCDDATA transition time	0.5		3.3	ns

Frame-to-frame timing is derived through the following parameters in the LCD Raster Timing 1 (LCDRASTRTIM1) register:

- Vertical front porch (VFP)
- Vertical sync pulse width (VSW)
- Vertical back porch (VBP)
- Lines per panel (MSBLPP + LPP)

Line-to-line timing is derived through the following parameters in the LCD Raster Timing 0 (LCDRASTRTIM0) register:

- Horizontal front porch (HFP)
- Horizontal sync pulse width (HSW)
- Horizontal back porch (HBP)
- Pixels per panel (PPLMSB + PPLLSB)

LCDAC timing is derived through the following parameter in the LCD Raster Timing 2 (LCDRASTRTIM2) register:

- AC bias frequency (ACBF)

图 5-58 shows the display format produced in raster mode. An entire frame is delivered one line at a time. The first line delivered starts at data pixel (1, 1) and ends at data pixel (P, 1). The last line delivered starts at data pixel (1, L) and ends at data pixel (P, L). The beginning of each new frame is denoted by the activation of I/O signal LCDFP (VSYNC). The beginning of each new line is denoted by the activation of I/O signal LCDLP (HSYNC).





图 5-58. LCD Raster-Mode Display Format



图 5-59. LCD Raster-Mode Active

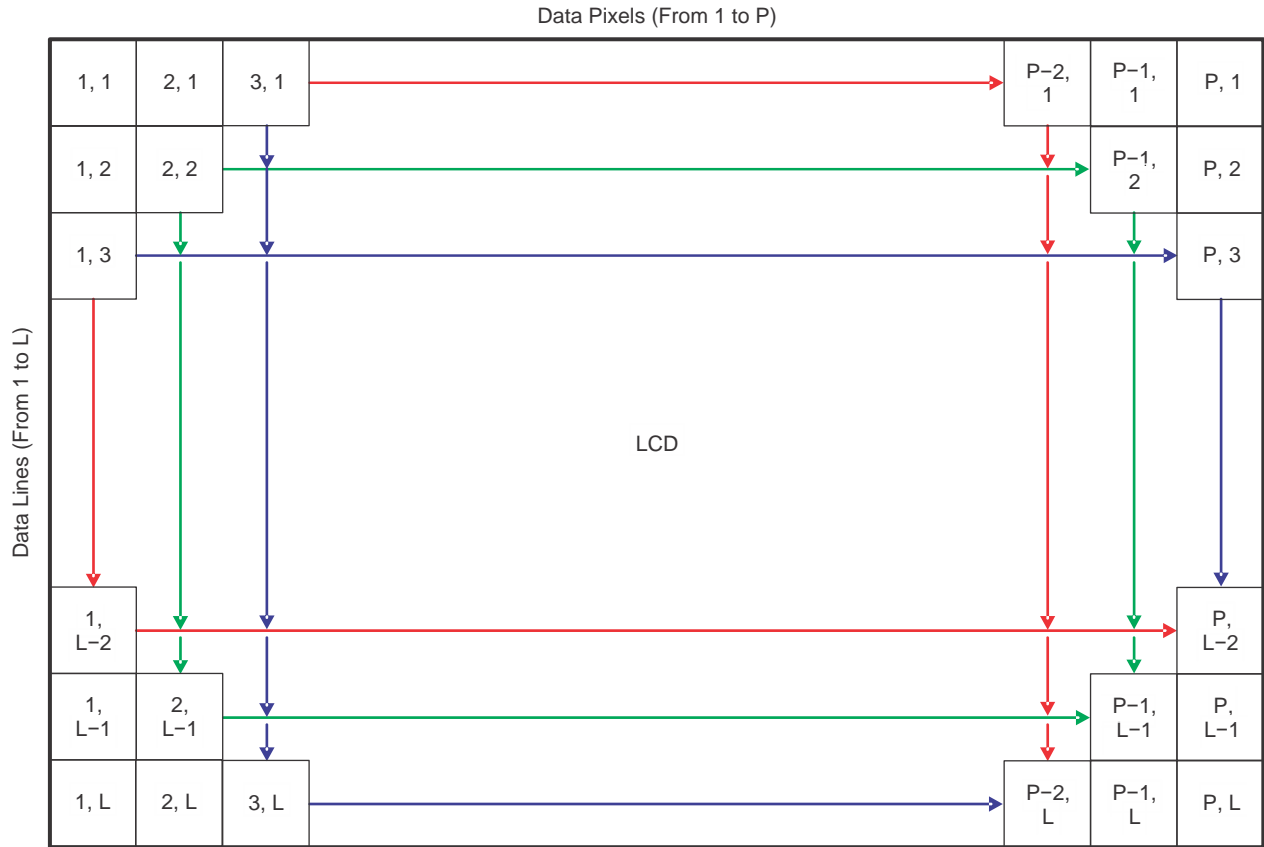

图 5-60. LCD Raster-Mode Passive

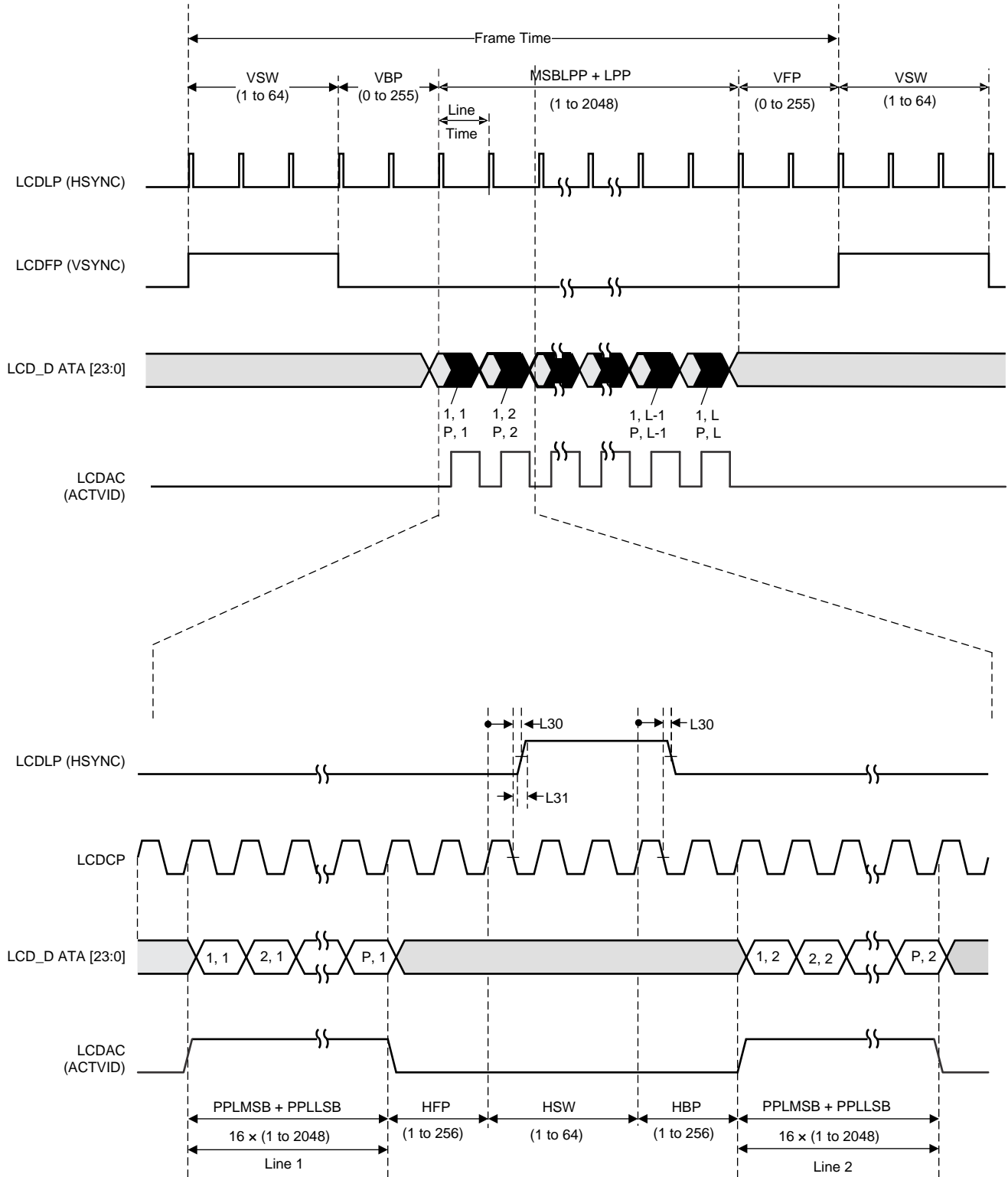

图 5-61. LCD Raster-Mode Control Signal Activation

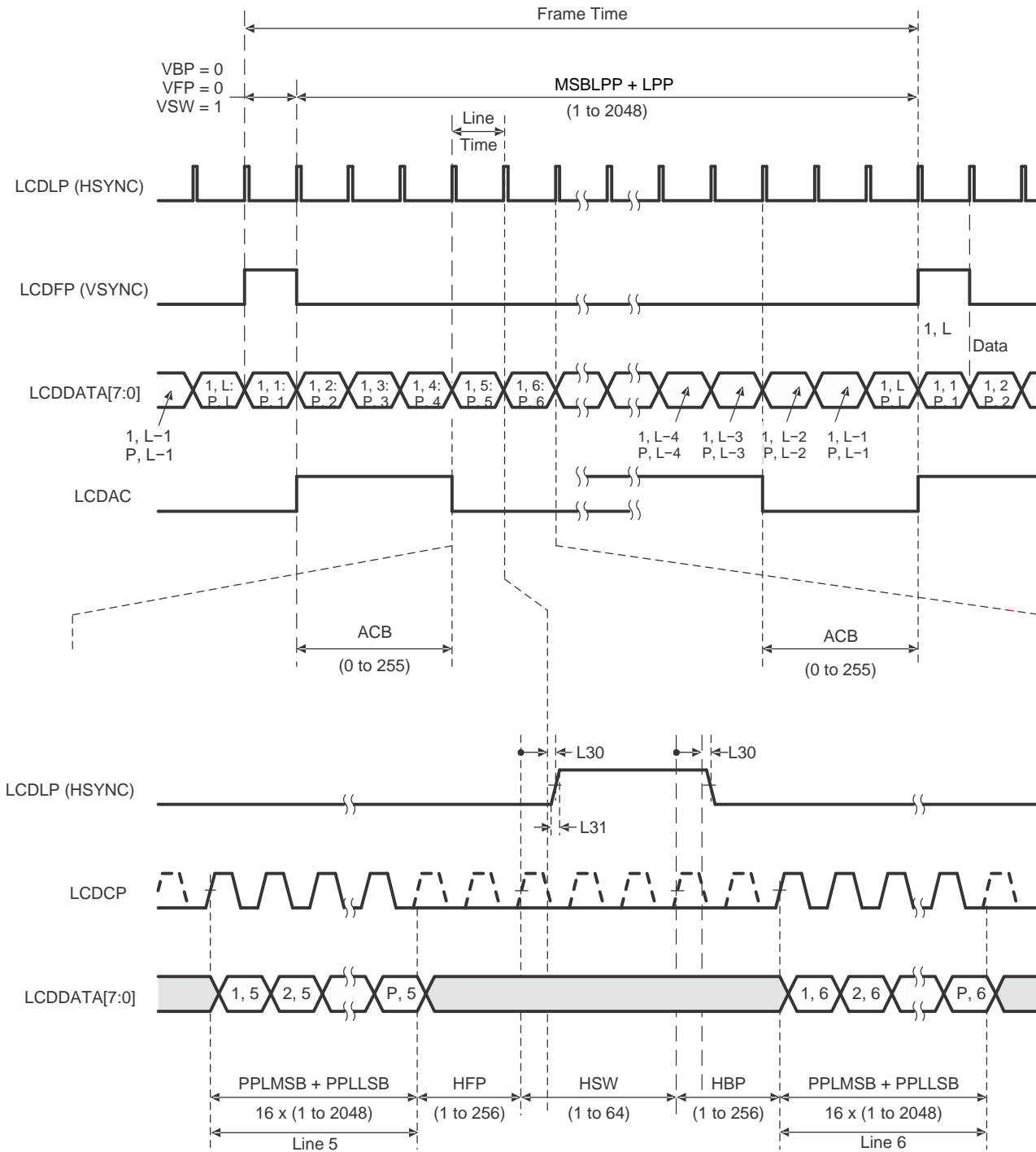

图 5-62. LCD Raster-Mode Control Signal Deactivation

### 5.15.17 Analog Comparator

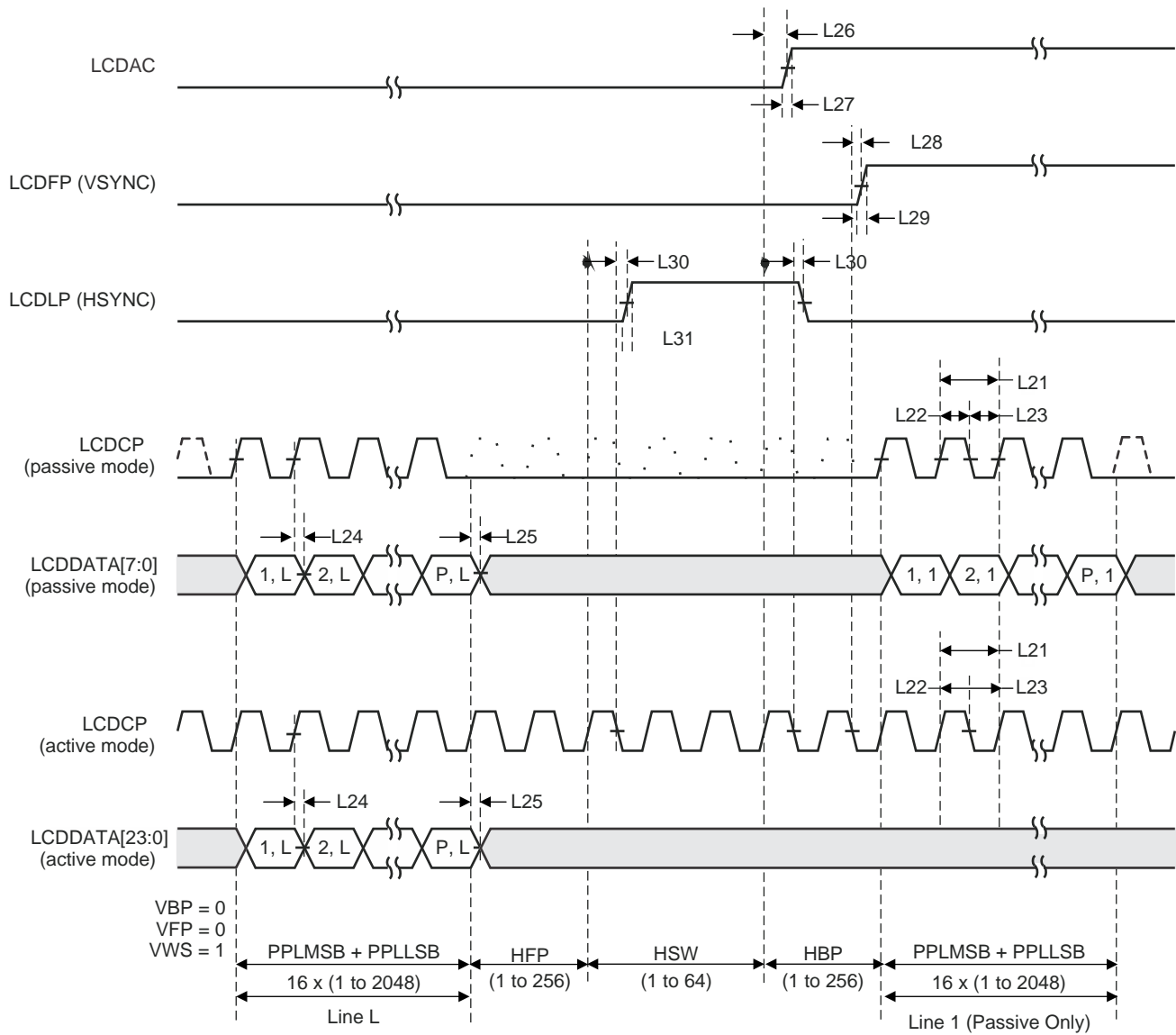
表 5-59 lists the characteristics of the comparator.

表 5-59. Analog Comparator Characteristics

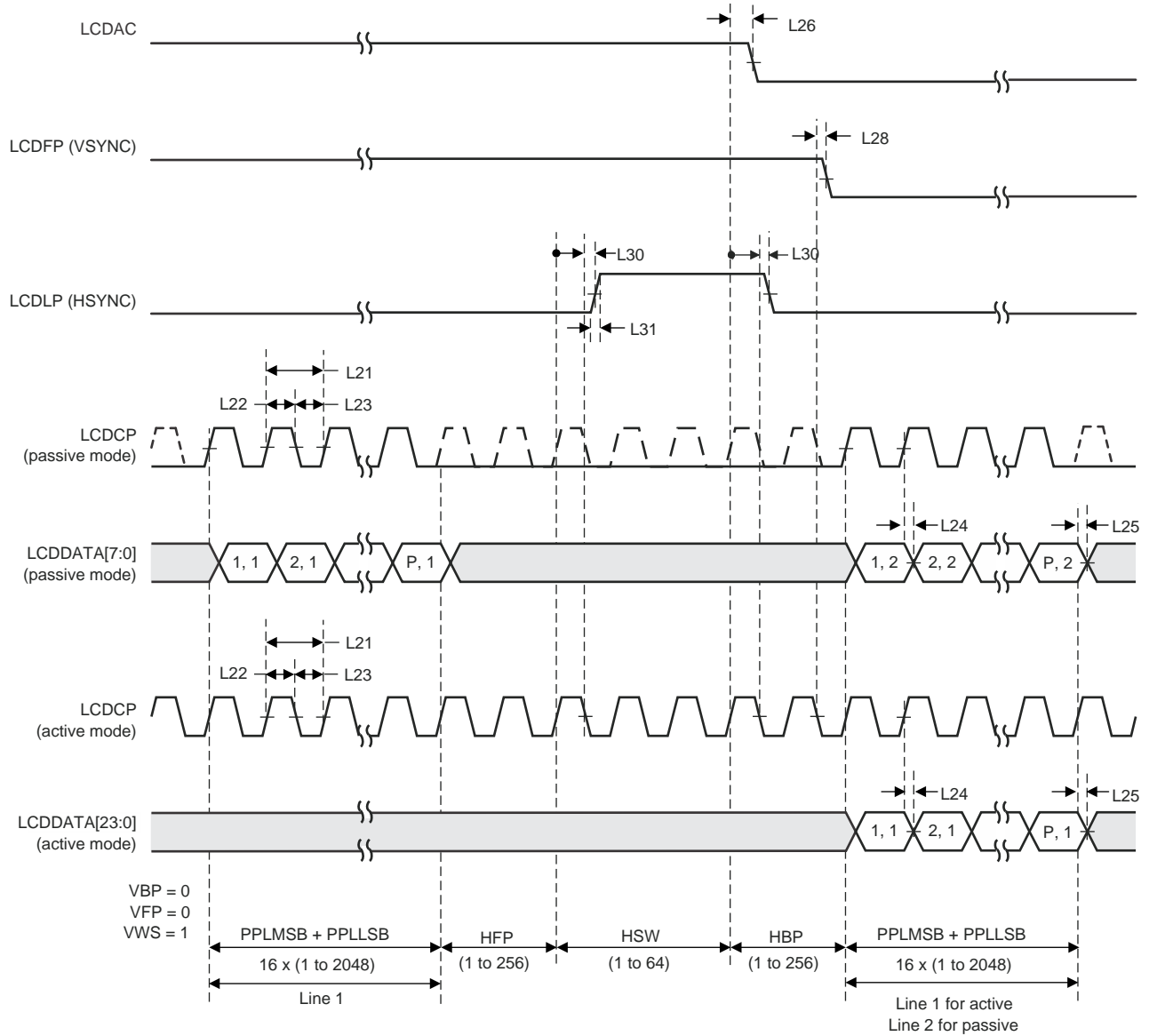
over operating free-air temperature (unless otherwise noted) <sup>(1)</sup> <sup>(2)</sup>

PARAMETER	MIN	TYP	MAX	UNIT
$V_{INP}$ , $V_{INN}$ <sup>(3)</sup> Input voltage range	GNDA		$V_{DDA}$	V
$V_{CM}$ Input common-mode voltage range	GNDA		$V_{DDA}$	V
$V_{OS}$ Input offset voltage		$\pm 10$	$\pm 50$ <sup>(4)</sup>	mV
$I_{INP}$ , $I_{INN}$ Input leakage current over full voltage range			2.0	$\mu A$
$C_{MRR}$ Common-mode rejection ratio		50		dB
$t_{RT}$ Response time			1.0 <sup>(5)</sup>	$\mu s$
$t_{MC}$ Comparator mode change to output valid			10	$\mu s$

- (1) Best design practices suggest placing static or quiet digital I/O signals adjacent to sensitive analog inputs to reduce capacitive coupling and crosstalk.
- (2) To achieve best analog results, keep the source resistance driving the analog inputs,  $V_{INP}$  and  $V_{INN}$ , low.
- (3) The external voltage inputs to the analog comparator are designed to be highly sensitive and can be affected by external noise on the board. For this reason,  $V_{INP}$  and  $V_{INN}$  must be set to different voltage levels during idle states to ensure the analog comparator triggers are not enabled. If an internal voltage reference is used, it should be set to a mid-supply level. When operating in sleep or deep-sleep modes, disable the analog comparator module or set the external voltage inputs to different levels (greater than the input offset voltage) to achieve minimum current draw.
- (4) Measured at  $V_{REF} = 100$  mV
- (5) Measured at external  $V_{REF} = 100$  mV, input signal switching from 75 mV to 125 mV

表 5-60 lists the characteristics for the comparator.

表 5-60. Analog Comparator Characteristics

over operating free-air temperature (unless otherwise noted)

PARAMETER	MIN	TYP	MAX	UNIT
$R_{HR}$ Resolution in high range		$V_{DDA} / 29.4$		V
$R_{LR}$ Resolution in low range		$V_{DDA} / 22.12$		V
$A_{HR}$ Absolute accuracy high range			$\pm R_{HR} / 2$	V
$A_{LR}$ Absolute accuracy low range			$\pm R_{LR} / 2$	V

表 5-61 和 表 5-62 list the reference voltages for the comparator under different conditions.

**表 5-61. Analog Comparator Voltage Reference Characteristics**

$V_{DDA} = 3.3\text{ V}$ ,  $EN = 1$ ,  $RNG = 0$ , over operating free-air temperature (unless otherwise noted)

PARAMETER	TEST CONDITIONS	MIN	TYP	MAX	UNIT
$V_{IREF}$ Reference voltage	$VREF = 0x0$	0.731	0.786	0.841	V
	$VREF = 0x1$	0.843	0.898	0.953	
	$VREF = 0x2$	0.955	1.010	1.065	
	$VREF = 0x3$	1.067	1.122	1.178	
	$VREF = 0x4$	1.180	1.235	1.290	
	$VREF = 0x5$	1.292	1.347	1.402	
	$VREF = 0x6$	1.404	1.459	1.514	
	$VREF = 0x7$	1.516	1.571	1.627	
	$VREF = 0x8$	1.629	1.684	1.739	
	$VREF = 0x9$	1.741	1.796	1.851	
	$VREF = 0xA$	1.853	1.908	1.963	
	$VREF = 0xB$	1.965	2.020	2.076	
	$VREF = 0xC$	2.078	2.133	2.188	
	$VREF = 0xD$	2.190	2.245	2.300	
	$VREF = 0xE$	2.302	2.357	2.412	
	$VREF = 0xF$	2.414	2.469	2.525	

**表 5-62. Analog Comparator Voltage Reference Characteristics**

$V_{DDA} = 3.3\text{ V}$ ,  $EN = 1$ ,  $RNG = 1$ , over operating free-air temperature (unless otherwise noted)

PARAMETER	TEST CONDITIONS	MIN	TYP	MAX	UNIT
$V_{IREF}$ Reference voltage	$VREF = 0x0$	0.000	0.000	0.074	V
	$VREF = 0x1$	0.076	0.149	0.223	
	$VREF = 0x2$	0.225	0.298	0.372	
	$VREF = 0x3$	0.374	0.448	0.521	
	$VREF = 0x4$	0.523	0.597	0.670	
	$VREF = 0x5$	0.672	0.746	0.820	
	$VREF = 0x6$	0.822	0.895	0.969	
	$VREF = 0x7$	0.971	1.044	1.118	
	$VREF = 0x8$	1.120	1.193	1.267	
	$VREF = 0x9$	1.269	1.343	1.416	
	$VREF = 0xA$	1.418	1.492	1.565	
	$VREF = 0xB$	1.567	1.641	1.715	
	$VREF = 0xC$	1.717	1.790	1.864	
	$VREF = 0xD$	1.866	1.939	2.013	
	$VREF = 0xE$	2.015	2.089	2.162	
	$VREF = 0xF$	2.164	2.238	2.311	

### 5.15.18 Pulse-Width Modulator (PWM)

表 5-63 lists the PWM timing characteristics.

表 5-63. PWM Timing Characteristics

over operating free-air temperature (unless otherwise noted)

PARAMETER		MIN	TYP	MAX	UNIT
$t_{FLTW}$	Minimum fault pulse width	2			PWM clock periods
$t_{FLTMAX}$	MnFAULTn assertion to PWM inactive <sup>(1)</sup>			24 + (1 PWM clock)	ns
$t_{FLTMIN}$	MnFAULTn deassertion to PWM active <sup>(2)</sup>	5			ns

(1) This parameter value can vary depending on the PWM clock frequency which is controlled by the System Clock and a programmable divider field in the PWMCC register.

(2) The latch and minimum fault period functions that can be enabled in the PWMnCTL register can change the timing of this parameter.

### 5.15.19 Emulation and Debug

表 5-64 lists the JTAG characteristics.

表 5-64. JTAG Characteristics

over operating free-air temperature (unless otherwise noted) (see 图 5-63 and 图 5-64)

NO.	PARAMETER		MIN	TYP	MAX	UNIT
J1	$f_{TCK}$	TCK operational clock frequency	0		10	MHz
J2	$t_{TCK}$	TCK operational clock period	100			ns
J3	$t_{TCK\_LOW}$	TCK clock low time		$t_{TCK} / 2$		ns
J4	$t_{TCK\_HIGH}$	TCK clock high time		$t_{TCK} / 2$		ns
J5	$t_{TCK\_R}$	TCK rise time	0		10	ns
J6	$t_{TCK\_F}$	TCK fall time	0		10	ns
J7	$t_{TMS\_SU}$	TMS setup time to TCK rise	8			ns
J8	$t_{TMS\_HLD}$	TMS hold time from TCK rise	4			ns
J9	$t_{TDI\_SU}$	TDI setup time to TCK rise	18			ns
J10	$t_{TDI\_HLD}$	TDI hold time from TCK rise	4			ns
J11	$t_{TDO\_ZDV}$	TCK fall to data valid from Hi-Z	2-mA drive	13	35	ns
			4-mA drive	9	26	
			8-mA drive	8	26	
			8-mA drive with slew rate control	10	29	
			10-mA drive	11	13	
J12	$t_{TDO\_DV}$	TCK fall to data valid from data valid	2-mA drive	14	20	ns
			4-mA drive	10	26	
			8-mA drive	8	21	
			8-mA drive with slew rate control	10	26	
			10-mA drive	12	14	
J13	$t_{TDO\_DVZ}$	TCK fall to Hi-Z from data valid	2-mA drive	7	16	ns
			4-mA drive	7	16	
			8-mA drive	7	16	
			8-mA drive with slew rate control	8	19	
			10-mA drive	20	22	
			12-mA drive	20	25	





图 5-63. JTAG Test Clock Input Timing



图 5-64. JTAG Test Access Port (TAP) Timing

## 6 Detailed Description

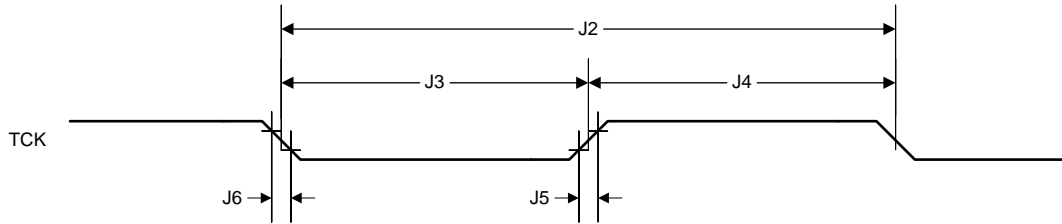
### 6.1 Overview

The SimpleLink MSP432E411Y Arm Cortex-M4 microcontroller (MCU) provides top performance and advanced integration. The MSP432E4 product family is positioned for cost-effective applications requiring significant control processing and connectivity capabilities such as the following:

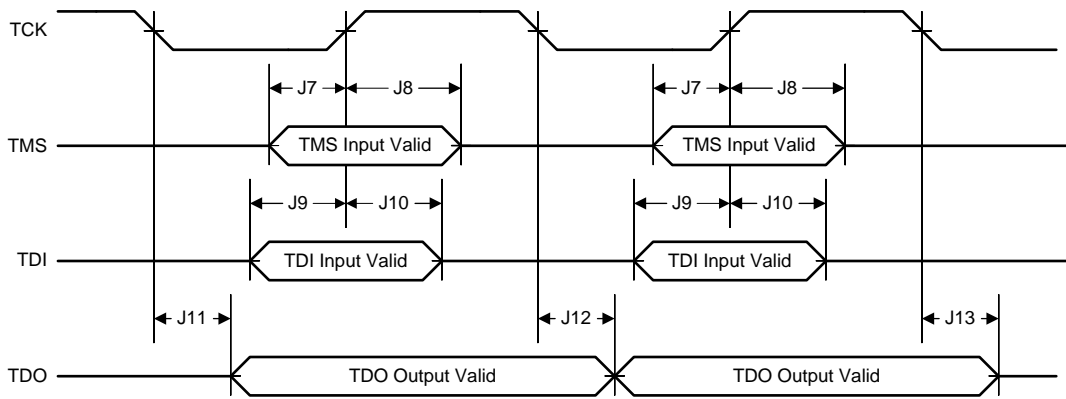
- Industrial communication equipment
- Network appliances, gateways, and adapters
- Residential and commercial site monitoring and control
- Remote connectivity and monitoring
- Security and access systems
- HMI control panels
- Factory automation control
- Test and measurement equipment
- Fire and security systems
- Motion control and power inversion
- Medical instrumentation
- Gaming equipment
- Electronic point-of-sale (POS) displays
- Smart energy and smart grid solutions
- Intelligent lighting control
- Vehicle tracking

The MSP432E411Y MCU integrates a large variety of rich communication features to enable a new class of highly connected designs that can support critical, real-time control with a balance between performance and power. The MCU features integrated communication peripherals and other high-performance analog and digital functions to offer a strong foundation for many different target uses, from human-machine interface to networked system management controllers.

In addition, the MSP432E411Y MCU offers the advantages of widely available development tools from Arm, System-on-Chip (SoC) infrastructure, and a large user community. Additionally, this MCU uses the Thumb-compatible Thumb-2 instruction set from Arm to reduce memory requirements and, thereby, cost. Finally, when using the SimpleLink SDK, the MSP432E411Y MCU is code-compatible with all members of the SimpleLink series, providing flexibility to fit precise needs.

TI offers a complete solution to get to market quickly, with evaluation and development boards; white papers and application notes; an easy-to-use peripheral driver library; and a strong support, sales, and distributor network.

## 6.2 Functional Block Diagram

图 6-1 shows the features on the MSP432E411Y MCU. Two on-chip buses connect the core to the peripherals. The Advanced Peripheral Bus (APB) bus is the legacy bus. The Advanced High-Performance Bus (AHB) bus provides better back-to-back access performance than the APB bus.

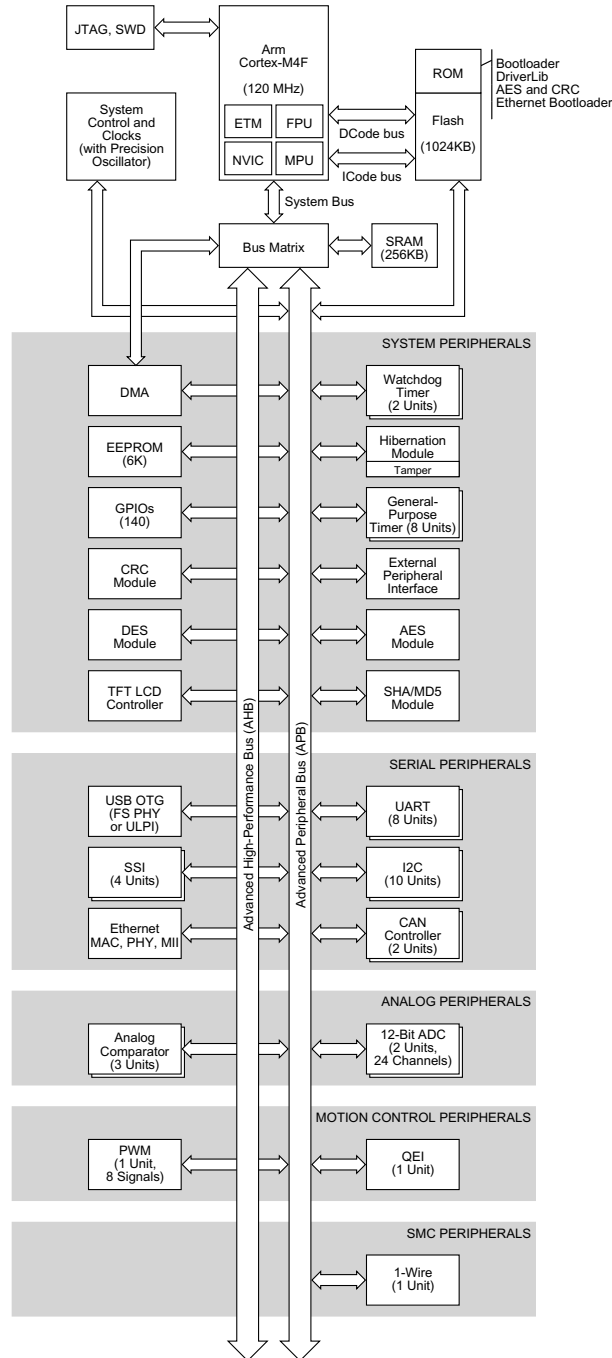

Copyright © 2017, Texas Instruments Incorporated

图 6-1. MSP432E411Y High-Level Block Diagram

## 6.3 Arm Cortex-M4F Processor Core

All members of the MSP432E4 family are designed around an Arm Cortex-M processor core. The Arm Cortex-M processor provides the core for a high-performance low-cost platform that meets the needs of minimal memory implementation, reduced pin count, and low power consumption, while delivering outstanding computational performance and exceptional system response to interrupts.

### 6.3.1 Processor Core

Features of the processor core include:

- 32-bit Arm Cortex-M4F architecture optimized for small-footprint embedded applications
- 120-MHz operation; 150 DMIPS performance
- Outstanding processing performance combined with fast interrupt handling
- Thumb-2 mixed 16- and 32-bit instruction set delivers the high performance expected of a 32-bit Arm core in a compact memory size usually associated with 8- and 16-bit devices, typically in the range of a few kilobytes of memory for MCU-class applications.
  - Single-cycle multiply instruction and hardware divide
  - Atomic bit manipulation (bit-banding), delivering maximum memory use and streamlined peripheral control
  - Unaligned data access, enabling data to be efficiently packed into memory
- IEEE 754-compliant single-precision floating-point unit (FPU)
- 16-bit SIMD vector processing unit
- Fast code execution permits slower processor clock or increases sleep mode time
- Harvard architecture characterized by separate buses for instruction and data
- Efficient processor core, system, and memories
- Hardware division and fast digital-signal-processing orientated multiply accumulate
- Saturating arithmetic for signal processing
- Deterministic high-performance interrupt handling for time-critical applications
- Memory protection unit (MPU) to provide a privileged mode for protected operating system functionality
- Enhanced system debug with extensive breakpoint and trace capabilities
- Serial Wire Debug and Serial Wire Trace reduce the number of pins required for debugging and tracing
- Migration from the Arm7<sup>®</sup> processor family for better performance and power efficiency
- Optimized for single-cycle flash memory use up to specific frequencies; see the *Internal Memory* chapter of the [MSP432E4 SimpleLink™ Microcontrollers Technical Reference Manual](#) for more information.
- Ultra-low-power consumption with integrated sleep modes

### 6.3.2 System Timer (SysTick)

SysTick provides a simple, 24-bit, clear-on-write, decrementing, wrap-on-zero counter with a flexible control mechanism. The counter can be used in several different ways, for example:

- An RTOS tick timer that fires at a programmable rate (for example, 100 Hz) and invokes a SysTick routine
- A high-speed alarm timer using the system clock
- A variable rate alarm or signal timer—the duration is range-dependent on the reference clock used and the dynamic range of the counter
- A simple counter used to measure time to completion and time used
- An internal clock-source control based on missing or meeting durations

### 6.3.3 Nested Vectored Interrupt Controller (NVIC)

The NVIC and Cortex-M4F core prioritize and handle all exceptions in handler mode. The processor state is automatically stored to the stack on an exception and automatically restored from the stack at the end of the interrupt service routine (ISR). The interrupt vector is fetched in parallel to the state saving, enabling efficient interrupt entry. The processor supports tail-chaining, meaning that back-to-back interrupts can be performed without the overhead of state saving and restoration. Software can set 8 priority levels on 7 exceptions (system handlers) and 109 interrupts.

- Deterministic, fast interrupt processing: always 12 cycles, or just 6 cycles with tail-chaining (these values reflect no FPU stacking)
- External nonmaskable interrupt signal (NMI) available for immediate execution of NMI handler for safety critical applications
- Dynamically reprioritizable interrupts
- Exceptional interrupt handling through hardware implementation of required register manipulations

表 6-1 lists the interrupts.

表 6-1. Interrupts

VECTOR NUMBER	INTERRUPT NUMBER (BIT IN INTERRUPT REGISTERS)	VECTOR ADDRESS OR OFFSET	DESCRIPTION
0 to 15	–	0x0000.0000 to 0x0000.003C	Processor exceptions
16	0	0x0000.0040	GPIO Port A
17	1	0x0000.0044	GPIO Port B
18	2	0x0000.0048	GPIO Port C
19	3	0x0000.004C	GPIO Port D
20	4	0x0000.0050	GPIO Port E
21	5	0x0000.0054	UART0
22	6	0x0000.0058	UART1
23	7	0x0000.005C	SSI0
24	8	0x0000.0060	I2C0
25	9	0x0000.0064	PWM fault
26	10	0x0000.0068	PWM generator 0
27	11	0x0000.006C	PWM generator 1
28	12	0x0000.0070	PWM generator 2
29	13	0x0000.0074	QE10
30	14	0x0000.0078	ADC0 sequence 0
31	15	0x0000.007C	ADC0 sequence 1
32	16	0x0000.0080	ADC0 sequence 2
33	17	0x0000.0084	ADC0 sequence 3
34	18	0x0000.0088	Watchdog timers 0 and 1
35	19	0x0000.008C	16-/32-Bit Timer 0A
36	20	0x0000.0090	16-/32-Bit Timer 0B
37	21	0x0000.0094	16-/32-Bit Timer 1A
38	22	0x0000.0098	16-/32-Bit Timer 1B
39	23	0x0000.009C	16-/32-Bit Timer 2A
40	24	0x0000.00A0	16-/32-Bit Timer 2B
41	25	0x0000.00A4	Analog comparator 0
42	26	0x0000.00A8	Analog comparator 1
43	27	0x0000.00AC	Analog comparator 2
44	28	0x0000.00B0	System control

表 6-1. Interrupts (continued)

VECTOR NUMBER	INTERRUPT NUMBER (BIT IN INTERRUPT REGISTERS)	VECTOR ADDRESS OR OFFSET	DESCRIPTION
45	29	0x0000.00B4	Flash memory control
46	30	0x0000.00B8	GPIO port F
47	31	0x0000.00BC	GPIO port G
48	32	0x0000.00C0	GPIO port H
49	33	0x0000.00C4	UART2
50	34	0x0000.00C8	SSI1
51	35	0x0000.00CC	16-/32-Bit Timer 3A
52	36	0x0000.00D0	16-/32-Bit Timer 3B
53	37	0x0000.00D4	I2C1
54	38	0x0000.00D8	CAN0
55	39	0x0000.00DC	CAN1
56	40	0x0000.00E0	Ethernet MAC
57	41	0x0000.00E4	HIB
58	42	0x0000.00E8	USB MAC
59	43	0x0000.00EC	PWM generator 3
60	44	0x0000.00F0	μDMA 0 Software
61	45	0x0000.00F4	μDMA 0 Error
62	46	0x0000.00F8	ADC1 sequence 0
63	47	0x0000.00FC	ADC1 sequence 1
64	48	0x0000.0100	ADC1 sequence 2
65	49	0x0000.0104	ADC1 sequence 3
66	50	0x0000.0108	EPI0
67	51	0x0000.010C	GPIO port J
68	52	0x0000.0110	GPIO port K
69	53	0x0000.0114	GPIO port L
70	54	0x0000.0118	SSI2
71	55	0x0000.011C	SSI3
72	56	0x0000.0120	UART3
73	57	0x0000.0124	UART4
74	58	0x0000.0128	UART5
75	59	0x0000.012C	UART6
76	60	0x0000.0130	UART7
77	61	0x0000.0134	I2C2
78	62	0x0000.0138	I2C3
79	63	0x0000.013C	Timer 4A
80	64	0x0000.0140	Timer 4B
81	65	0x0000.0144	Timer 5A
82	66	0x0000.0148	Timer 5B
83	67	0x0000.014C	Floating-Point Exception (imprecise)
84	68	–	Reserved
85	69	–	Reserved
86	70	0x0000.0158	I2C4
87	71	0x0000.015C	I2C5
88	72	0x0000.0160	GPIO port M
89	73	0x0000.0164	GPIO port N
90	74	–	Reserved

**表 6-1. Interrupts (continued)**

VECTOR NUMBER	INTERRUPT NUMBER (BIT IN INTERRUPT REGISTERS)	VECTOR ADDRESS OR OFFSET	DESCRIPTION
91	75	0x0000.016C	Tamper
92	76	0x0000.017	GPIO port P (Summary or P0)
93	77	0x0000.0174	GPIO port P1
94	78	0x0000.0178	GPIO port P2
95	79	0x0000.017C	GPIO port P3
96	80	0x0000.0180	GPIO port P4
97	81	0x0000.0184	GPIO port P5
98	82	0x0000.0188	GPIO port P6
99	83	0x0000.018C	GPIO port P7
100	84	0x0000.0190	GPIO port Q (summary or Q0)
101	85	0x0000.0194	GPIO port Q1
102	86	0x0000.0198	GPIO port Q2
103	87	0x0000.019C	GPIO port Q3
104	88	0x0000.01A0	GPIO port Q4
105	89	0x0000.01A4	GPIO port Q5
106	90	0x0000.01A8	GPIO port Q6
107	91	0x0000.01AC	GPIO port Q7
108	92	0x0000.01B0	GPIO port R
109	93	0x0000.01B4	GPIO port S
110	94	0x0000.01B8	SHA/MD5
111	95	0x0000.01BC	AES
112	96	0x0000.01C0	DES
113	97	0x0000.01C4	LCD
114	98	0x0000.01C8	16-/32-Bit Timer 6A
115	99	0x0000.01CC	16-/32-Bit Timer 6B
116	100	0x0000.01D0	16-/32-Bit Timer 7A
117	101	0x0000.01D4	16-/32-Bit Timer 7B
118	102	0x0000.01D8	I2C6
119	103	0x0000.01DC	I2C7
120	104	–	Reserved
121	105	0x0000.01E4	1-Wire
122	106	–	Reserved
123	107	–	Reserved
124	108	–	Reserved
125	109	0x0000.01F4	I2C8
126	110	0x0000.01F8	I2C9
127	111	0x0000.01FC	GPIO port T

### 6.3.4 System Control Block (SCB)

The SCB provides system implementation information and system control, including configuration, control, and reporting of system exceptions.

### 6.3.5 Memory Protection Unit (MPU)

The MPU supports the standard Arm7 Protected Memory System Architecture (PMSA) model. The MPU provides full support for protection regions, overlapping protection regions, access permissions, and exporting memory attributes to the system.

### 6.3.6 Floating-Point Unit (FPU)

The FPU fully supports single-precision add, subtract, multiply, divide, multiply-and-accumulate, and square root operations. It also provides conversions between fixed-point and floating-point data formats, and floating-point constant instructions.

- 32-bit instructions for single-precision (C float) data-processing operations
- Combined multiply and accumulate instructions for increased precision (fused MAC)
- Hardware support for conversion, addition, subtraction, multiplication with optional accumulate, division, and square-root
- Hardware support for denormals and all IEEE rounding modes
- 32 dedicated 32-bit single-precision registers, also addressable as 16 double-word registers
- Decoupled 3-stage pipeline

### 6.4 On-Chip Memory

The following on-chip memories are supported:

- 256KB of single-cycle SRAM
- 1024KB of flash memory
- 6KB of EEPROM
- Internal ROM loaded with SimpleLink SDK software:
  - Peripheral driver library
  - Bootloader

#### 6.4.1 SRAM

The MSP432E411Y MCU provides 256KB of single-cycle on-chip SRAM. The internal SRAM of the device is at offset 0x2000.0000 of the device memory map.

The SRAM is implemented using four 32-bit-wide interleaving SRAM banks (separate SRAM arrays), which allow for increased speed between memory accesses. The SRAM memory provides nearly 2 GBps of memory bandwidth at a 120-MHz clock frequency.

Because read-modify-write (RMW) operations are time consuming, Arm has introduced bit-banding technology in the Cortex-M4F processor. With a bit-band-enabled processor, certain regions in the memory map (SRAM and peripheral space) can use address aliases to access individual bits in an atomic operation.

Data can be transferred to and from SRAM by the following masters:

- $\mu$ DMA
- USB
- LCD controller
- Ethernet controller

#### 6.4.2 Flash Memory

The MSP432E411Y MCU provides 1024KB of on-chip flash memory. The flash memory is configured as four banks of 16K  $\times$  128 bits (4  $\times$  256KB total) that are 2-way interleaved. Memory blocks can be marked as read only or execute only, providing different levels of code protection. Read-only blocks cannot be erased or programmed, protecting the contents of those blocks from being modified. Execute-only blocks cannot be erased or programmed, and can only be read by the controller instruction fetch mechanism, protecting the contents of those blocks from being read by either the controller or a debugger.

Two sets of instruction prefetch buffers provide enhanced performance and power savings. Each prefetch buffer is 2  $\times$  256 bits and can be combined as a 4  $\times$  256-bit prefetch buffer.

The flash can also be accessed by the  $\mu$ DMA in run mode.



### 6.4.3 ROM

The ROM is preprogrammed with the following software and programs:

- Peripheral driver library
- Bootloader

The SimpleLink MSP432E4 SDK driver library is a royalty-free software library for controlling on-chip peripherals with a bootloader capability. The library performs both peripheral initialization and control functions, with a choice of polled or interrupt-driven peripheral support. In addition, the library is designed to take full advantage of the stellar interrupt performance of the Arm Cortex-M4F core. No special pragmas or custom assembly code prologue or epilogue functions are required. For applications that require in-field programmability, the royalty-free bootloader can act as an application loader and support in-field firmware updates.

### 6.4.4 EEPROM

The EEPROM includes the following features:

- 6KB of memory accessible as 1536 32-bit words
- 96 blocks of 16 words (64 bytes) each
- Built-in wear leveling
- Access protection per block
- Lock protection option for the whole peripheral as well as per block using 32-bit to 96-bit unlock codes (application selectable)
- Interrupt support for write completion to avoid polling
- Endurance of 500k writes (when writing at fixed offset in every alternate page in circular fashion) to 15M operations (when cycling through two pages) per each 2-page block.

## 6.4.5 Memory Map

The device supports a 4GB address space that is divided into eight 512MB zones (see [图 6-2](#)).

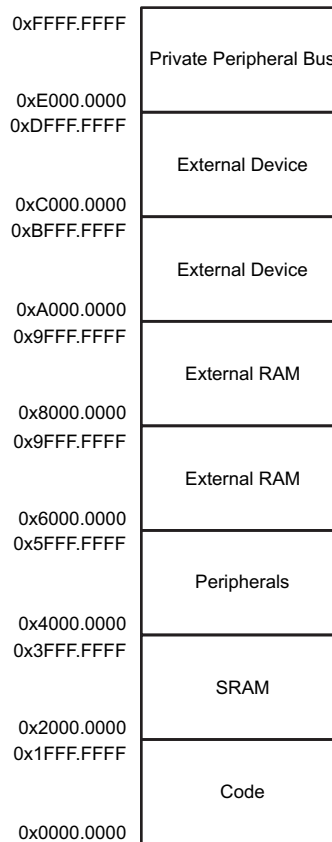

**图 6-2. Device Memory Zones**

## 6.5 Peripherals

### 6.5.1 External Peripheral Interface (EPI)

The EPI provides access to external devices using a parallel path. Unlike communications peripherals such as SSI, UART, and I<sup>2</sup>C, the EPI acts as a bus to external peripherals and memory.

The EPI has the following features:

- 8-, 16-, or 32-bit dedicated parallel bus for external peripherals and memory
- Memory interface supports contiguous memory access independent of data bus width, thus enabling code execution directly from SDRAM, SRAM, and flash memory
- Blocking and nonblocking reads
- Separates processor from timing details through use of an internal write FIFO
- Efficient transfers using  $\mu$ DMA
  - Separate channels for read and write
  - Read channel request asserted by programmable levels on the internal Nonblocking Read FIFO (NBRFIFO)
  - Write channel request asserted by empty on the internal Write FIFO (WFIFO)

The EPI supports three primary functional modes: SDRAM mode, traditional host-bus mode, and general-purpose mode. The EPI module also provides custom GPIOs; however, unlike regular GPIOs, the EPI module uses a FIFO in the same way as a communication mechanism and is speed-controlled using clocking.

- SDRAM mode
  - Supports  $\times 16$  (single data rate) SDRAM at up to 60 MHz
  - Supports low-cost SDRAMs up to 64MB (512 Mb)
  - Includes automatic refresh and access to all banks and rows
  - Includes a sleep (standby) mode to keep contents active with minimal power draw
  - Multiplexed address and data interface for reduced pin count
- Host-bus mode
  - Traditional  $\times 8$  and  $\times 16$  MCU bus interface capabilities
  - Similar device compatibility options as PIC, ATmega, 8051, and others
  - Access to SRAM, NOR flash memory, and other devices, with up to 1MB of addressing in nonmultiplexed mode and 256MB in multiplexed mode (512MB in host bus 16 mode with no byte selects)
  - Support for up to 512Mb PSRAM in quad chip select mode, with dedicated configuration register read and write enable
  - Support of both muxed and demuxed address and data
  - Access to a range of devices supporting the nonaddress FIFO  $\times 8$  and  $\times 16$  interface variant, with support for external FIFO (XFIFO) EMPTY and FULL signals
  - Speed controlled, with read and write data wait-state counters
  - Support for read or write burst mode to Host Bus
  - Multiple chip-select modes including single, dual, and quad chip selects, with and without ALE
  - External iRDY signal provided for stall capability of reads and writes
  - Manual chip-enable (or use extra address pins)
- General-purpose mode
  - Wide parallel interfaces for fast communications with CPLDs and FPGAs
  - Data widths up to 32 bits
  - Data rates up to 150 MB/second
  - Optional "address" sizes from 4 bits to 20 bits
  - Optional clock output, read and write strobes, framing (with counter-based size), and clock-enable input
- General parallel GPIO
  - 1 to 32 bits, FIFO with speed control
  - Useful for custom peripherals or for digital data acquisition and actuator controls

### 6.5.2 Cyclical Redundancy Check (CRC)

The CRC computation module is for uses such as message transfer and safety system checks. This module can be used with the AES and DES modules. The CRC has the following features:

- Support four major CRC forms:
  - CRC16-CCITT as used by CCITT/ITU X.25
  - CRC16-IBM as used by USB and ANSI
  - CRC32-IEEE as used by IEEE 802.3 and MPEG-2
  - CRC32C as used by G.Hn
- Allows word and byte feed
- Supports automatic initialization and manual initialization
- Supports MSb and LSb
- Supports CCITT post-processing
- Can be fed by  $\mu$ DMA, flash memory, and code

### 6.5.3 Advanced Encryption Standard (AES) Accelerator

The AES accelerator module provides hardware-accelerated data encryption and decryption operations based on a binary key. The AES module is a symmetric cipher module that supports a 128-, 192-, or 256-bit key in hardware for both encryption and decryption.

The AES has following features:

- Support for basic AES encryption and decryption operations:
  - Galois/counter mode (GCM) with basic GHASH operation
  - Counter mode with CBC-MAC (CCM)
  - XTS mode
- Availability of the following feedback operating modes:
  - Electronic code book mode (ECB)
  - Cipher block chaining mode (CBC)
  - Counter mode (CTR)
  - Cipher feedback mode (CFB), 128-bit
  - F8 mode
- Key sizes 128-, 192-, and 256-bits
- Support for CBC\_MAC and Fedora 9 (F9) authentication modes
- Basic GHASH operation (when selecting no encryption)
- Key scheduling in hardware
- Support for  $\mu$ DMA transfers
- Fully synchronous design

### 6.5.4 Data Encryption Standard (DES) Accelerator

The DES module provides hardware accelerated data encryption and decryption functions. The module runs either the single DES or the triple DES (3DES) algorithm and supports electronic codebook (ECB), cipher block chaining (CBC), and cipher feedback (CFB) modes of operation.

The DES accelerator includes the following main features:

- DES/3DES encryption and decryption algorithm compliant with the [FIPS 180-3 standard](#)
- Feedback modes: ECB, CBC, CFB
- Host interrupt or  $\mu$ DMA driven modes of operation.  $\mu$ DMA support for data and context in and result out
- Fully synchronous design
- Internal wide-bus interface

### 6.5.5 Secure Hash Algorithm/Message Digest Algorithm (SHA/MD5) Accelerator

The SHA/MD5 module provides hardware-accelerated hash functions and can run:

- MD5 message digest algorithm developed by Ron Rivest in 1991
- SHA-1 algorithm compliant with the [FIPS 180-3 standard](#)
- SHA-2 (SHA-224 and SHA-256) algorithm compliant with the [FIPS 180-3 standard](#)
- Hash message authentication code (HMAC) operation

The algorithms produce a condensed representation of a message or a data file, which can then be used to verify the message integrity.

The SHA/MD5 accelerator module includes the following main features:

- Hashing of 0 to  $(2^{33} - 2)$  bytes of data [of which  $(2^{32} - 1)$  bytes are in one pass] using the MD5, SHA-1, SHA-224, or SHA-256 hash algorithm (byte granularity only, no support for bit granularity)
- Automatic HMAC key preprocessing for HMAC keys up to 64 bytes

- Host-assisted HMAC key preprocessing for HMAC keys larger than 64 bytes
- HMAC from precomputes (inner and outer digest) for improved performance on small blocks
- Supports  $\mu$ DMA operation for data and context in and result out transfers
- Supports interrupt to read the digest (signature)

### 6.5.6 Serial Communications Peripherals

Both asynchronous and synchronous serial communications are supported with:

- 10/100 Ethernet MAC with advanced IEEE 1588 PTP hardware and both media independent interface (MII) and reduced MII (RMII) support; integrated PHY provided
- Two CAN 2.0 A and B controllers
- USB 2.0 controller OTG, host, or device with optional high speed using external PHY through ULPI interface
- Eight UARTs with IrDA, 9-bit, and ISO 7816 support
- 1-wire master module that can provide power and data over one bidirectional wire
- Ten I2C modules with four transmission speeds including high-speed mode
- Four Quad Synchronous Serial Interface (QSSI) modules with bi- and quad-SSI support

The following sections provide more detail on each of these communications functions.

#### 6.5.6.1 Ethernet MAC and PHY

The Ethernet controller consists of a fully integrated media access controller (MAC) and network physical (PHY) interface with the following features:

- Conforms to the IEEE 802.3 specification
  - 10BASE-T and 100BASE-TX IEEE-802.3 compliant
  - Supports 10- and 100-Mbps data transmission rates
  - Supports full-duplex and half-duplex (CSMA/CD) operation
  - Supports flow control and back pressure
  - Full-featured and enhanced auto-negotiation
  - Supports IEEE 802.1Q VLAN tag detection
- Conforms to IEEE 1588-2002 timestamp PTP protocol and the IEEE 1588-2008 advanced timestamp specification
  - Transmit and receive frame timestamping
  - Precision time protocol
  - Flexible pulse per second output
  - Supports coarse and fine correction methods
- Multiple addressing modes
  - Four MAC address filters
  - Programmable 64-bit hash filter for multicast address filtering
  - Promiscuous mode support
- Processor offloading
  - Programmable insertion (TX) or deletion (RX) of preamble and start-of-frame data
  - Programmable generation (TX) or deletion (RX) of CRC and pad data
  - IP header and hardware checksum checking (IPv4, IPv6, TCP, UDP, ICMP)
- Highly configurable
  - LED activity selection
  - Supports network statistics with RMON and MIB counters
  - Supports magic packet and wake-up frames

- Efficient transfers using integrated  $\mu$ DMA
  - Dual-buffer (ring) or linked-list (chained) descriptors
  - Round-robin or fixed priority arbitration between TX and RX
  - Descriptors support transfer blocks size up to 8KB
  - Programmable interrupts for flexible system implementation
- Physical media manipulation
  - MDI/MDI-X cross-over support
  - Register-programmable transmit amplitude
  - Automatic polarity correction and 10BASE-T signal reception
- MII and RMI support

### 6.5.6.2 Controller Area Network (CAN)

CAN is a multicast shared serial-bus standard for connecting electronic control units (ECUs). CAN was specifically designed to be robust in electromagnetically noisy environments and can use a differential balanced line like RS-485 or twisted-pair wire. Originally created for automotive purposes, it is now used in many embedded control applications (for example, industrial or medical). Bit rates up to 1 Mbps are possible at network lengths below 40 meters. Decreased bit rates allow longer network distances (for example, 125 kbps at 500 m).

A transmitter sends a message to all CAN nodes (broadcasting). Each node decides on the basis of the identifier received whether it should process the message. The identifier also determines the priority that the message enjoys in competition for bus access. Each CAN message can transmit from 0 to 8 bytes of user information.

Each of the two CAN units includes the following features:

- CAN protocol version 2.0 part A/B
- Bit rates up to 1 Mbps
- 32 message objects with individual identifier masks
- Maskable interrupt
- Disable Automatic Retransmission mode for Time-Triggered CAN (TTCAN) applications
- Programmable loopback mode for self-test operation
- Programmable FIFO mode enables storage of multiple message objects
- Gluelessly attaches to an external CAN transceiver through the CANnTX and CANnRX signals

### 6.5.6.3 Universal Serial Bus (USB)

USB is a serial bus standard designed to allow connection and disconnection of peripherals using a standardized interface without rebooting the system.

One USB controller supports high-speed and full-speed multiple-point communications and complies with the USB 2.0 standard for high-speed function. The USB controller can have three configurations: USB device, USB host, and USB OTG (negotiated on-the-go as host or device when connected to other USB-enabled systems). Support for full-speed communication is provided by using the integrated USB PHY or optionally, a high-speed ULPI can communicate to an external PHY.

The USB module has the following features:

- Complies with USB-IF (Implementer's Forum) certification standards
- USB 2.0 high-speed (480 Mbps) operation with the integrated ULPI communicating with an external PHY
- Link power-management support that uses link-state awareness to reduce power usage
- Four transfer types: control, interrupt, bulk, and isochronous

- 16 endpoints
  - 1 dedicated control IN endpoint and 1 dedicated control OUT endpoint
  - 7 configurable IN endpoints and 7 configurable OUT endpoints
- 4KB of dedicated endpoint memory: one endpoint may be defined for double-buffered 1023-byte isochronous packet size
- VBUS droop detection and interrupt
- Integrated USB DMA with bus master capability
  - Up to eight RX endpoint channels and up to eight TX endpoint channels are available.
  - Each channel can be separately programmed to operate in different modes.
  - Incremental burst transfers of 4, 8, 16, or unspecified length supported

#### 6.5.6.4 Universal Asynchronous Receiver/Transmitter (UART)

A UART is an integrated circuit used for RS-232C serial communications, containing a transmitter (parallel-to-serial converter) and a receiver (serial-to-parallel converter), each clocked separately.

Eight fully programmable 16C550-type UARTs are integrated. Although the functionality is similar to a 16C550 UART, this UART design is not register compatible. The UART can generate individually masked interrupts from the RX, TX, modem flow control, modem status, and error conditions. The module generates one combined interrupt when any of the interrupts are asserted and are unmasked.

The UARTs have the following features:

- Programmable baud-rate generator allowing speeds up to 7.5 Mbps for regular speed (divide by 16) and 15 Mbps for high speed (divide by 8)
- Separate 16x8 transmit (TX) and receive (RX) FIFOs to reduce CPU interrupt service loading
- Programmable FIFO length, including a 1-byte-deep operation providing conventional double-buffered interface
- FIFO trigger levels of 1/8, 1/4, 1/2, 3/4, and 7/8
- Standard asynchronous communication bits for start, stop, and parity
- Line-break generation and detection
- Fully programmable serial interface characteristics
  - 5, 6, 7, or 8 data bits
  - Even, odd, stick, or no-parity bit generation/detection
  - 1 or 2 stop bit generation
- IrDA serial-IR (SIR) encoder and decoder providing
  - Programmable use of IrDA Serial Infrared (SIR) or UART I/O
  - Support of IrDA SIR encoder and decoder functions for data rates up to 115.2 kbps half-duplex
  - Support of normal 3/16 and low-power (1.41 to 2.23  $\mu$ s) bit durations
  - Programmable internal clock generator enabling division of reference clock by 1 to 256 for low-power mode bit duration
- Support for communication with ISO 7816 smart cards
- Modem functionality available on the following UARTs:
  - UART0 (modem flow control and modem status)
  - UART1 (modem flow control and modem status)
  - UART2 (modem flow control)
  - UART3 (modem flow control)
  - UART4 (modem flow control)
- EIA-485 9-bit support
- Standard FIFO-level and end-of-transmission interrupts

- Efficient transfers using  $\mu$ DMA
  - Separate channels for transmit and receive
  - Receive single request asserted when data is in the FIFO; burst request asserted at programmed FIFO level
  - Transmit single request asserted when there is space in the FIFO; burst request asserted at programmed FIFO level
- The Global Alternate Clock (ALTCLK) resource or System Clock (SYSCLK) can be used to generate the baud clock

#### 6.5.6.5 1-Wire Master Module

1-Wire is a bidirectional serial communication protocol that provides both power and data over one wire. The 1-Wire Master module can interface with a multiple variety of slaves such as thermometers, mixed-signal devices, memory, and authentication devices.

The 1-Wire Master module supports the following features:

- Supports standard and overdrive speeds, including a late-sample mechanism
- Allows transfers of send, receive, and bidirectional bits
- Data size transfers of 1, 2, 3, or 4 bytes with subbyte search and enumeration support
- Interrupt capability for transaction pacing and line error
- Optional 2-wire support for isolated lines and high-voltage use
- Efficient transfers using  $\mu$ DMA

#### 6.5.6.6 Inter-Integrated Circuit (I<sup>2</sup>C)

The I<sup>2</sup>C bus provides bidirectional data transfer through a 2-wire design (a serial data line SDA and a serial clock line SCL). The I<sup>2</sup>C bus interfaces to external I<sup>2</sup>C devices such as serial memory (RAMs and ROMs), networking devices, LCDs, tone generators, and so on. The I<sup>2</sup>C bus can also be used for system testing and diagnostic purposes in product development and manufacture.

Each device on the I<sup>2</sup>C bus can be designated as either a master or a slave. The I<sup>2</sup>C module supports both sending and receiving data as either a master or a slave and can operate simultaneously as both a master and a slave. Both the I<sup>2</sup>C master and slave can generate interrupts.

The I<sup>2</sup>C modules include the following features:

- Devices on the I<sup>2</sup>C bus can be designated as either a master or a slave
  - Supports both transmitting and receiving data as either a master or a slave
  - Supports simultaneous master and slave operation
- Four I<sup>2</sup>C modes
  - Master transmit
  - Master receive
  - Slave transmit
  - Slave receive
- Two 8-entry FIFOs for receive and transmit data
  - FIFOs can be independently assigned to master or slave
- Four transmission speeds:
  - Standard (100 kbps)
  - Fast-mode (400 kbps)
  - Fast-mode plus (1 Mbps)
  - High-speed mode (3.33 Mbps)
- Glitch suppression



- SMBus support through software
  - Clock low time-out interrupt
  - Dual slave address capability
  - Quick command capability
- Master and slave interrupt generation
  - Master generates interrupts when a transmit or receive operation completes (or aborts due to an error)
  - Slave generates interrupts when data has been transferred or requested by a master or when a START or STOP condition is detected
- Master with arbitration and clock synchronization, multiple-master support, and 7-bit addressing mode
- Efficient transfers using  $\mu$ DMA
  - Separate channels for transmit and receive
  - Ability to execute single data transfers or burst data transfers using the RX and TX FIFOs in the I<sup>2</sup>C

### 6.5.6.7 Quad Synchronous Serial Interface (QSSI)

QSSI is a bidirectional communications interface that converts data between parallel and serial. The QSSI module performs serial-to-parallel conversion on data received from a peripheral device and performs parallel-to-serial conversion on data transmitted to a peripheral device. The QSSI module can be configured as either a master or slave device. As a slave device, the QSSI module can also be configured to disable its output, which allows a master device to be coupled with multiple slave devices. The TX and RX paths are buffered with separate internal FIFOs.

The QSSI module also includes a programmable bit rate clock divider and prescaler to generate the output serial clock derived from the input clock of the QSSI module. Bit rates are generated based on the input clock, and the maximum bit rate is determined by the connected peripheral.

The four QSSI modules each support the following features:

- Four QSSI channels with advanced, bi-SSI, and quad-SSI functionality
- Programmable interface operation for Freescale SPI or TI synchronous serial interfaces in legacy mode. Support for Freescale interface in Bi- and Quad-SSI mode.
- Master or slave operation
- Programmable clock bit rate and prescaler
- Separate transmit and receive FIFOs, each 16 bits wide and 8 locations deep
- Programmable data frame size from 4 to 16 bits
- Internal loopback test mode for diagnostic/debug testing
- Standard FIFO-based interrupts and end-of-transmission interrupt
- Efficient transfers using  $\mu$ DMA
  - Separate channels for transmit and receive
  - Receive single request asserted when data is in the FIFO; burst request asserted when FIFO contains four entries
  - Transmit single request asserted when there is space in the FIFO; burst request asserted when four or more entries are available to be written in the FIFO
  - Maskable  $\mu$ DMA interrupts for receive and transmit complete
- Global alternate clock (ALTCLK) resource or system clock (SYSCLK) can be used to generate baud clock.

### 6.5.7 System Integration

A variety of standard system functions are integrated into the device, including:

- Direct memory access (DMA) controller (see [节 6.5.7.1](#))
- System control and clocks including on-chip precision 16-MHz oscillator (see [节 6.5.7.2](#))

- Eight 32-bit timers (each timer can be configured as two 16-bit timers) (see 节 6.5.7.3)
- Lower-power battery-backed Hibernation module (see 节 6.5.7.5)
- RTC in Hibernation module
- Two watchdog timers (see 节 6.5.7.6)
  - One timer runs off the main oscillator.
  - One timer runs off the precision internal oscillator.
- 140 GPIOs, depending on configuration (see 节 6.5.7.7)
  - Highly flexible pin multiplexing allows use as GPIO or one of several peripheral functions.
  - GPIOs are independently configurable to 2-, 4-, 8-, 10-, or 12-mA drive capability.
  - Up to 4 GPIOs can have 18-mA drive capability.

### 6.5.7.1 Direct Memory Access (DMA)

The DMA controller is known as micro-DMA ( $\mu$ DMA). The  $\mu$ DMA controller provides a way to offload data transfer tasks from the Cortex-M4F processor, allowing for more efficient use of the processor and the available bus bandwidth. The  $\mu$ DMA controller can perform transfers between memory and peripherals. It has dedicated channels for each supported on-chip module and can be programmed to automatically perform transfers between peripherals and memory as the peripheral is ready to transfer more data. The  $\mu$ DMA controller provides the following features:

- Arm PrimeCell 32-channel configurable  $\mu$ DMA controller
- Support for memory-to-memory, memory-to-peripheral, and peripheral-to-memory in multiple transfer modes
  - Basic for simple transfer scenarios
  - Ping-pong for continuous data flow
  - Scatter-gather for a programmable list of up to 256 arbitrary transfers initiated from one request
- Highly flexible and configurable channel operation
  - Independently configured and operated channels
  - Dedicated channels for supported on-chip modules
  - Flexible channel assignments
  - One channel each for receive and transmit path for bidirectional modules
  - Dedicated channel for software-initiated transfers
  - Per-channel configurable priority scheme
  - Optional software-initiated requests for any channel
- Two levels of priority
- Design optimizations for improved bus access performance between  $\mu$ DMA controller and the processor core
  - $\mu$ DMA controller access is subordinate to core access
  - RAM striping
  - Peripheral bus segmentation
- Data sizes of 8, 16, and 32 bits
- Transfer size is programmable in binary steps from 1 to 1024
- Source and destination address increment size of byte, halfword, word, or no increment
- Maskable peripheral requests
- Interrupt on transfer completion, with a separate interrupt per channel

Each DMA channel has up to nine possible assignments that are selected using the DMA Channel Map Select n (DMACHMAPn) registers with 4-bit assignment fields for each  $\mu$ DMA channel.

表 6-2 lists the  $\mu$ DMA channel mapping. The Encoding column lists the encoding for the respective DMACHMAPn bit field. Encodings 0x9 to 0xF are reserved. The Type column indicates if a particular peripheral uses a single request (S), burst request (B), or either (SB).

注

Channels or encodings marked as Reserved cannot be used for  $\mu$ DMA transfers. Channels designated in the table as only "Software" are dedicated software channels. When only one software request is required in an application, dedicated software channels can be used. If multiple software requests in code are required, then peripheral channel software requests should be used for proper  $\mu$ DMA completion acknowledgement.

表 6-2.  $\mu$ DMA Channel Assignments

Channel	Encoding																	
	0		1		2		3		4		5		6		7		8	
	Peripheral	Type	Peripheral	Type	Peripheral	Type	Peripheral	Type	Peripheral	Type	Peripheral	Type	Peripheral	Type	Peripheral	Type	Peripheral	Type
0	Reserved	–	UART2 RX	SB	Reserved	–	GPTimer 4A	B	Reserved	–	Reserved	–	I2C0 RX	SB	Reserved	–	Reserved	–
1	Reserved	–	UART2 TX	SB	Reserved	–	GPTimer 4B	B	Reserved	–	Reserved	–	I2C0 TX	SB	Reserved	–	Reserved	–
2	Reserved	–	GPTimer 3A	B	Reserved	–	Reserved	–	Reserved	–	Reserved	–	I2C1RX	SB	Reserved	–	Reserved	–
3	Reserved	–	GPTimer 3B	B	Reserved	–	Software	S	Reserved	–	Reserved	–	I2C1 TX	SB	Reserved	–	Reserved	–
4	Reserved	–	GPTimer 2A	B	Reserved	–	GPIO A	B	Reserved	–	SHA/MD5 0 Cin	B	I2C2 RX	SB	Reserved	–	Reserved	–
5	Reserved	–	GPTimer 2B	B	Reserved	–	GPIO B	B	Reserved	–	SHA/MD5 0 Din	B	I2C2 TX	SB	Reserved	–	Reserved	–
6	Reserved	–	GPTimer 2A	B	UART5 RX	SB	GPIO C	B	I2C0 RX	SB	SHA/MD5 0 Cout	B	Reserved	–	Reserved	–	Reserved	–
7	Reserved	–	GPTimer 2B	B	UART5 TX	SB	GPIO D	B	I2C0 TX	SB	Reserved	–	Reserved	–	Reserved	–	Reserved	–
8	UART0 RX	SB	UART1 RX	SB	Reserved	–	GPTimer 5A	B	I2C1RX	SB	Reserved	–	Reserved	–	Reserved	–	Reserved	–
9	UART0 TX	SB	UART1 TX	SB	Reserved	–	GPTimer 5B	B	I2C1 TX	SB	Reserved	–	Reserved	–	Reserved	–	Reserved	–
10	SSIO RX	SB	SSI1 RX	SB	UART6 RX	SB	Reserved	–	I2C2 RX	SB	Reserved	–	Reserved	–	GPTimer 6A	B	Reserved	–
11	SSIO TX	SB	SSI1 TX	SB	UART6 TX	SB	Reserved	–	I2C2 TX	SB	Reserved	–	Reserved	–	GPTimer 6B	B	Reserved	–
12	Reserved	–	UART2 RX	SB	SSI2 RX	SB	Reserved	–	GPIO K	B	AES0 Cin	B	Reserved	–	GPTimer 7A	B	Reserved	–
13	Reserved	–	UART2 TX	SB	SSI2 TX	SB	Reserved	–	GPIO L	B	AES0 Cout	B	Reserved	–	GPTimer 7B	B	Reserved	–
14	ADC0 SS0	SB	GPTimer 2A	B	SSI3 RX	SB	GPIO E	B	GPIO M	B	AES0 Din	B	Reserved	–	Reserved	–	Reserved	–
15	ADC0 SS1	SB	GPTimer 2B	B	SSI3 TX	SB	GPIO F	B	GPIO N	B	AES0 Dout	B	Reserved	–	Reserved	–	Reserved	–
16	ADC0 SS2	SB	Reserved	–	UART3 RX	SB	Reserved	–	GPIO P	B	Reserved	–	Reserved	–	Reserved	–	Reserved	–
17	ADC0 SS3	SB	Reserved	–	UART3 TX	SB	Reserved	–	Reserved	–	Reserved	–	Reserved	–	Reserved	–	Reserved	–
18	GPTimer 0A	B	GPTimer 1A	B	UART4 RX	SB	GPIO B	B	I2C3 RX	SB	Reserved	–	Reserved	–	Reserved	–	Reserved	–
19	GPTimer 0B	B	GPTimer 1B	B	UART4 TX	SB	GPIO G	B	I2C3 TX	SB	Reserved	–	Reserved	–	Reserved	–	Reserved	–
20	GPTimer 1A	B	EPIO RX Software	B	UART7 RX	SB	GPIO H	B	I2C4 RX	SB	DES0 Cin	B	Reserved	–	Reserved	–	Reserved	–
21	GPTimer 1B	B	EPIO TX Software	B	UART7 TX	SB	GPIO J	B	I2C4 TX	SB	DES0 Din	B	Reserved	–	Reserved	–	Reserved	–
22	UART1 RX	SB	Software	B	Reserved	–	Software	B	I2C5 RX	SB	DES0 Dout	B	Reserved	–	Reserved	–	I2C8 RX	B
23	UART1 TX	SB	Software	B	Reserved	–	Software	B	I2C5 TX	SB	Reserved	–	Reserved	–	Reserved	–	I2C8 TX	B
24	SSI1 RX	SB	ADC1 SS0	SB	Reserved	–	Reserved	–	GPIO Q	B	Reserved	–	Reserved	–	Reserved	–	I2C9 RX	B
25	SSI1 TX	SB	ADC1 SS1	SB	Reserved	–	Reserved	–	GPIO R	B	Reserved	–	Reserved	–	Reserved	–	I2C9 TX	B

表 6-2.  $\mu$ DMA Channel Assignments (continued)

Channel	Encoding																	
	0		1		2		3		4		5		6		7		8	
	Peripheral	Type	Peripheral	Type	Peripheral	Type	Peripheral	Type	Peripheral	Type	Peripheral	Type	Peripheral	Type	Peripheral	Type	Peripheral	Type
26	Software	B	ADC1 SS2	SB	Reserved	–	Reserved	–	GPIO S	B	Reserved	–	Reserved	–	Reserved	–	I2C6 RX	B
27	Software	B	ADC1 SS3	SB	Reserved	–	Reserved	–	Reserved	–	Reserved	–	GPIO T	B	Reserved	–	I2C6 TX	B
28	Reserved	–	Reserved	–	Reserved	–	Reserved	–	Reserved	–	Reserved	–	Reserved	–	Reserved	–	I2C7 RX	B
29	Reserved	–	Reserved	–	Reserved	–	Reserved	–	Reserved	–	Reserved	–	Reserved	–	Reserved	–	I2C7 TX	B
30	Software	B	Software	B	Reserved	–	Software	B	Reserved	–	Reserved	–	Reserved	–	EPI0 RX	B	1Wire0	B
31	Reserved	–	Reserved	–	Reserved	–	Reserved	B	Reserved	–	Reserved	–	Reserved	–	EPI0 TX	B	Reserved	–

### 6.5.7.2 System Control and Clocks

System control determines the overall operation of the device. It provides information about the device, controls power-saving features, controls the clocking of the device and individual peripherals, and handles reset detection and reporting.

- Device identification information: version, part number, SRAM size, flash memory size, and so on
- Power control
  - On-chip fixed low dropout (LDO) voltage regulator
  - Hibernation module manages the power-up and power-down 3.3-V sequencing and control for the core digital logic and analog circuits
  - Low-power options for MCU: sleep and deep-sleep modes with clock gating
  - Low-power options for on-chip modules: software controls shutdown of individual peripherals and memory
  - 3.3-V supply brownout detection and reporting through interrupt or reset
- Multiple clock sources for the system clock. The MCU is clocked by the system clock (SYSCLK) that is distributed to the processor and integrated peripherals after clock gating. The SYSCLK frequency is based on the frequency of the clock source and a divisor factor. A PLL is provided for the generation of system clock frequencies in excess of the reference clock provided. The reference clocks for the PLL are the PIOSC and the main crystal oscillator. The following clock sources are provided to the MCU:
  - 16-MHz precision oscillator (PIOSC)
  - Main oscillator (MOSC): A frequency-accurate clock source by one of two means: an external single-ended clock source is connected to the OSC0 input pin, or an external crystal is connected across the OSC0 input and OSC1 output pins.
  - Low-frequency internal oscillator (LFIOSC): On-chip resource used during power-saving modes.
  - Hibernate RTC oscillator (RTCOSC): A clock that can be configured to be the 32.768-kHz external oscillator source from the HIB module or the HIB low-frequency clock source (HIB LFIOSC), which is in the HIB module.
- Flexible reset sources
  - Power-on reset (POR)
  - Reset pin assertion
  - Brownout reset (BOR) detector alerts to system power drops
  - Software reset
  - Watchdog timer reset
  - Hibernation module event
  - MOSC failure
- 128-bit unique identifier for individual device identification

### 6.5.7.3 Programmable Timers

Programmable timers can be used to count or time external events that drive the Timer input pins. Each 16- or 32-bit General-Purpose Timer Module (GPTM) block provides two 16-bit timers/counters that can be configured to operate independently as timers or event counters. These two timers/counters can also be configured to operate as one 32-bit timer or one 32-bit RTC. Timers can also be used to trigger analog-to-digital conversions and DMA transfers.

The GPTM contains eight 16- or 32-bit GPTM blocks with the following functional options:

- Operating modes
  - 16- or 32-bit programmable one-shot timer
  - 16- or 32-bit programmable periodic timer
  - 16-bit general-purpose timer with an 8-bit prescaler
  - 32-bit RTC when using an external 32.768-kHz clock as the input
  - 16-bit input-edge count- or time-capture modes with an 8-bit prescaler
  - 16-bit PWM mode with an 8-bit prescaler and software-programmable output inversion of the PWM signal
- Count up or down
- Sixteen 16- or 32-bit capture/compare PWM (CCP) pins
- Daisy-chaining of timer modules lets one timer initiate multiple timing events
- Timer synchronization lets selected timers start counting on the same clock cycle
- ADC event trigger
- User-enabled stalling when the MCU asserts the CPU halt flag during debug (excluding RTC mode)
- Can determine the elapsed time between the assertion of the timer interrupt and entry into the ISR
- Efficient transfers using  $\mu$ DMA
  - Dedicated channel for each timer
  - Burst request generated on timer interrupt

#### 6.5.7.4 Capture Compare PWM (CCP) Pins

CCP pins can be used by the General-Purpose Timer module to time or count external events using the CCP pin as an input. Alternatively, the GPTM can generate a simple PWM output on the CCP pin.

The 16/32-bit CCP pins can be programmed to operate in the following modes:

- Capture: The GP timer is incremented or decremented by programmed events on the CCP input. The GP timer captures and stores the current timer value when a programmed event occurs.
- Compare: The GP timer is incremented or decremented by programmed events on the CCP input. The GP timer compares the current value with a stored value and generates an interrupt when a match occurs.
- PWM: The GP timer is incremented or decremented by the system clock. A PWM signal is generated based on a match between the counter value and a value stored in a match register and is output on the CCP pin.

#### 6.5.7.5 Hibernation (HIB) Module

The HIB module provides logic to switch power off to the main processor and peripherals and to wake on external or time-based events. The HIB module includes power-sequencing logic and has the following features:

- 32-bit RTC with 1/32768-second resolution and a 15-bit subseconds counter
  - 32-bit RTC seconds match register and a 15-bit subseconds match for timed wakeup and interrupt generation with 1/32768-second resolution
  - RTC predivider trim for making fine adjustments to the clock rate
- Hardware calendar function
  - Year, month, day, day of week, hours, minutes, and seconds
  - Four-year leap compensation
  - 24-hour or AM and PM configuration
- Two mechanisms for power control
  - System power control using a discrete external regulator
  - On-chip power control using internal switches under register control
- $V_{DD}$  supplies power when valid, even if  $V_{BAT} > V_{DD}$

- Dedicated pin for wake using an external signal
- Can configure the external reset ( $\overline{\text{RST}}$ ) pin or up to four GPIO port pins as wake sources, with programmable wake level
- Tamper functionality
  - Support for four tamper inputs
  - Configurable level, weak pullup, and glitch filter
  - Configurable tamper event response
  - Logging of up to four tamper events
  - Optional BBRAM erase on tamper detection
  - Tamper detection and wake-from-hibernate capability
  - Hibernation clock input failure detect with a switch to the internal oscillator on detection
- RTC operational and hibernation memory valid as long as  $V_{\text{DD}}$  or  $V_{\text{BAT}}$  is valid
- Low-battery detection, signaling, and interrupt generation, with optional wake on low battery
- GPIO pin state can be retained during hibernation
- Clock source from an internal low-frequency oscillator (HIB LFIOOSC) or a 32.768-kHz external crystal or oscillator
- Sixteen 32-bit words of battery-backed memory to save state during hibernation
- Programmable interrupts for:
  - RTC match
  - External wake
  - Low battery

#### 6.5.7.6 Watchdog Timers

A watchdog timer is used to regain control when a system has failed due to a software error or to the failure of an external device to respond in the expected way. The watchdog timer can generate an interrupt, a nonmaskable interrupt, or a reset when a time-out value is reached. In addition, the watchdog timer is Arm FIRM-compliant and can be configured to generate an interrupt to the MCU on its first time-out, and to generate a reset signal on its second time-out. After the watchdog timer has been configured, the lock register can be written to prevent inadvertently altering the timer configuration.

Two watchdog timer modules are supported: Watchdog Timer 0 uses the system clock for its timer clock; Watchdog Timer 1 uses the PIOOSC as its timer clock. The watchdog timer module has the following features:

- 32-bit down counter with a programmable load register
- Separate watchdog clock with an enable
- Programmable interrupt generation logic with interrupt masking and optional NMI function
- Lock register protection from runaway software
- Reset generation logic with an enable/disable
- User-enabled stalling when the MCU asserts the CPU Halt flag during debug

#### 6.5.7.7 Programmable GPIOs

General-purpose input/output (GPIO) pins offer flexibility for a variety of connections. The GPIO module is composed of 18 physical GPIO blocks, each corresponding to an individual GPIO port. The GPIO module is FIRM-compliant (compliant to the Arm Foundation IP for Real-Time MCUs specification) and supports 0 to 140 programmable I/O pins. The number of GPIOs available depends on the peripherals being used.

- Up to 140 GPIOs, depending on configuration
- Highly flexible pin multiplexing allows use as GPIO or one of several peripheral functions
- 3.3-V tolerant in input configuration

- Advanced high-performance bus (AHB) accesses all ports:
  - Ports A to H, J to N, and P to T
- Fast toggle capable of a change every clock cycle for ports on AHB
- Programmable control for GPIO interrupts
  - Interrupt generation masking
  - Edge-triggered on rising, falling, or both
  - Level-sensitive on high or low values
  - Per-pin interrupts available on port P and port Q
- Bit masking in both read and write operations through address lines
- Can be used to initiate an ADC sample sequence or a  $\mu$ DMA transfer
- Pin state can be retained during hibernation mode; pins on port P can be programmed to wake on level in hibernation mode
- Pins configured as digital inputs are Schmitt triggered
- Programmable control for GPIO pad configuration
  - Weak pullup or pulldown resistors
  - 2-, 4-, 6-, 8-, 10-, or 12-mA pad drive for digital communication; up to four pads can sink 18-mA for high-current applications
  - Slew rate control for 8-, 10-, and 12-mA pad drive
  - Open-drain enables
  - Digital-input enables

### 6.5.8 LCD Controller

The LCD controller supports the following features:

- Character-based panels
  - Support for two character panels (CS0 and CS1) with independent and programmable bus timing parameters when in asynchronous Hitachi, Motorola, and Intel modes
  - Support for one character panel (CS0) with programmable bus timing parameters when in synchronous Motorola and Intel modes
  - Can be used as a generic 16-bit address and data interleaved MPU bus master with no external stall
- Passive matrix LCD panels
  - Panel types including STN, DSTN, and C-DSTN
  - AC Bias Control
- Active matrix LCD panels
  - Panel types including TN TFT
  - 1, 2, 4, or 8 bits per pixel with palette RAM and 16 or 24 bits per pixel without palette RAM
- OLED panels
  - Passive matrix (PM OLED) with frame buffer and controller IC inside the panel
  - Active matrix (AM OLED)
- Bus mastering from either system SRAM or EPI memory

### 6.5.9 Advanced Motion Control

The motion control functions that are integrated into the device support the following features:

- Eight advanced PWM outputs for motion and energy applications
- Four fault inputs to promote low-latency shutdown
- One quadrature encoder input (QEI)

The following sections provides more detail on these motion control functions.



### 6.5.9.1 Pulse Width Modulation (PWM)

PWM is a powerful technique for digitally encoding analog signal levels. High-resolution counters are used to generate a square wave, and the duty cycle of the square wave is modulated to encode an analog signal. Typical applications include switching power supplies and motor control.

One PWM module is included, with four PWM generator blocks and a control block, for a total of eight PWM outputs. Each PWM generator block contains one timer (16-bit down or up/down counter), two comparators, a PWM signal generator, a dead-band generator, and an interrupt or ADC-trigger selector.

Each PWM generator block produces two PWM signals that can be either independent signals or a pair of complementary signals with dead-band delays inserted.

Each PWM generator has the following features:

- Four fault-condition handling inputs to quickly provide low-latency shutdown and prevent damage to the motor being controlled
- One 16-bit counter
  - Runs in down or up/down mode
  - Output frequency controlled by a 16-bit load value
  - Synchronized load value updates
  - Produces output signals at zero and load value
- Two PWM comparators
  - Synchronized comparator value updates
  - Produces output signals on match
- PWM signal generator
  - Output PWM signal is constructed based on actions taken as a result of the counter and PWM comparator output signals.
  - Produces two independent PWM signals
- Dead-band generator
  - Produces two PWM signals with programmable dead-band delays suitable for driving a half-H bridge
  - Can be bypassed, leaving input PWM signals unmodified
- Can initiate an ADC sample sequence

The control block determines the polarity of the PWM signals and which signals are passed through to the pins. The output of the PWM generation blocks are managed by the output control block before being passed to the device pins. The PWM control block has the following options:

- PWM output enable of each PWM signal
- Optional output inversion of each PWM signal (polarity control)
- Optional fault handling for each PWM signal
- Synchronization of timers in the PWM generator blocks
- Synchronization of timer/comparator updates across the PWM generator blocks
- Extended PWM synchronization of timer/comparator updates across the PWM generator blocks
- Interrupt status summary of the PWM generator blocks
- Extended PWM fault handling, with multiple fault signals, programmable polarities, and filtering
- PWM generators can be operated independently or synchronized with other generators

### 6.5.9.2 Quadrature Encoder With Index (QEI) Module

A quadrature encoder, also known as a 2-channel incremental encoder, converts linear displacement into a pulse signal. By monitoring both the number of pulses and the relative phase of the two signals, the position, direction of rotation, and speed can be tracked. In addition, a third channel, or index signal, can be used to reset the position counter. The QEI module interprets the code produced by a quadrature encoder wheel to integrate position over time and determine direction of rotation. In addition, it can capture a running estimate of the velocity of the encoder wheel. The input frequency of the QEI inputs may be as high as 1/4 of the system frequency (for example, 30 MHz for a 120-MHz system).

One QEI module provides control of one motor with the following features:

- Position integrator that tracks the encoder position
- Programmable noise filter on the inputs
- Velocity capture using built-in timer
- The input frequency of the QEI inputs may be as high as 1/4 of the system frequency (for example, 12.5 MHz for a 50-MHz system)
- Interrupt generation on:
  - Index pulse
  - Velocity-timer expiration
  - Direction change
  - Quadrature error detection

### 6.5.10 Analog

Integrated analog functions include:

- Two 12-bit ADCs with a total of 24 analog input channels and each with a sample rate of 2 Msp/s (see [节 6.5.10.1](#))
- Three analog comparators (see [节 6.5.10.2](#))
- On-chip voltage regulator

#### 6.5.10.1 ADC

An ADC is a peripheral that converts a continuous analog voltage to a discrete digital number. The ADC module features 12-bit conversion resolution and supports 24 input channels plus an internal temperature sensor. Four buffered sample sequencers allow rapid sampling of up to 24 analog input sources without controller intervention. Each sample sequencer provides flexible programming with fully configurable input source, trigger events, interrupt generation, and sequencer priority. Each ADC module has a digital comparator function that lets the conversion value be sent to a comparison unit that provides eight digital comparators.

Both ADC modules support the following features:

- 24 shared analog input channels
- 12-bit precision ADC
- Single-ended and differential-input configurations
- On-chip internal temperature sensor
- Maximum sample rate of two million samples/second
- Optional, programmable phase delay
- Sample and hold window programmability
- Four programmable sample conversion sequencers from one to eight entries long, with corresponding conversion result FIFOs

- Flexible trigger control
  - Controller (software)
  - Timers
  - Analog comparators
  - PWM
  - GPIO
- Hardware averaging of up to 64 samples
- Eight digital comparators
- Converter uses two external reference signals (VREFA+ and VREFA–) or VDDA and GNDA as the voltage reference
- Power and ground for the analog circuitry is separate from the digital power and ground
- Efficient transfers using  $\mu$ DMA
  - Dedicated channel for each sample sequencer
  - ADC module uses burst requests for DMA
- Global Alternate Clock (ALTCLK) resource or System Clock (SYSCLK) can be used to generate ADC clock.

### 6.5.10.2 Analog Comparators

An analog comparator is a peripheral that compares two analog voltages and provides a logical output that signals the comparison result. The independent integrated analog comparators can be configured to drive an output or generate an interrupt or ADC event.

The comparator can provide its output to a device pin, acting as a replacement for an analog comparator on the board, or it can be used to signal the application via interrupts or triggers to the ADC to cause it to start capturing a sample sequence. The interrupt generation and ADC triggering logic is separate. This means, for example, that an interrupt can be generated on a rising edge and the ADC triggered on a falling edge.

Each analog comparator supports the following functions:

- Compare external pin input to external pin input or to internal programmable voltage reference
- Compare a test voltage against any one of the following voltages:
  - An individual external reference voltage
  - A shared single external reference voltage
  - A shared internal reference voltage

### 6.5.11 JTAG and Arm Serial Wire Debug

The Joint Test Action Group (JTAG) port is an IEEE standard that defines a Test Access Port (TAP) and Boundary Scan Architecture for digital integrated circuits and provides a standardized serial interface for controlling the associated test logic. The TAP, Instruction Register (IR), and Data Register (DR) can be used to test the interconnections of assembled printed circuit boards and obtain manufacturing information on the components. The JTAG port also provides a means of accessing and controlling design-for-test features such as I/O pin observation and control, scan testing, and debugging. TI replaces the Arm SW-DP and JTAG-DP with the Arm Serial Wire JTAG Debug Port (SWJ-DP) interface. The SWJ-DP interface combines the SWD and JTAG debug ports into one module. This module provides the standard JTAG debug and test functionality plus real-time access to system memory without halting the core or requiring any target resident code. The SWJ-DP interface has the following features:

- IEEE 1149.1-1990 compatible TAP controller
- Four-bit IR chain for storing JTAG instructions
- IEEE standard instructions: BYPASS, IDCODE, SAMPLE/PRELOAD, and EXTEST
- Arm additional instructions: APACC, DPACC, and ABORT

- Integrated Arm Serial Wire Debug (SWD)
  - Serial Wire JTAG Debug Port (SWJ-DP)
  - Flash Patch and Breakpoint (FPB) unit for implementing breakpoints
  - Data Watchpoint and Trace (DWT) unit for implementing watchpoints, trigger resources, and system profiling
  - Instrumentation Trace Macrocell (ITM) for support of printf-style debugging
  - Embedded Trace Macrocell (ETM) for instruction trace capture
  - Trace Port Interface Unit (TPIU) for bridging to a Trace Port Analyzer

### 6.5.12 Peripheral Memory Map

表 6-3 lists the address for each peripheral.

注

Within the memory map, attempts to read or write addresses in reserved spaces result in a bus fault. In addition, attempts to write addresses in the flash range also result in a bus fault.

表 6-3. Memory Map

START	END	DESCRIPTION	REGISTERS
0x4000.0000	0x4000.0FFF	Watchdog Timer 0	表 6-34
0x4000.1000	0x4000.1FFF	Watchdog Timer 1	表 6-34
0x4000.2000	0x4000.3FFF	Reserved	
0x4000.4000	0x4000.4FFF	GPIO Port A	表 6-18
0x4000.5000	0x4000.5FFF	GPIO Port B	表 6-18
0x4000.6000	0x4000.6FFF	GPIO Port C	表 6-18
0x4000.7000	0x4000.7FFF	GPIO Port D	表 6-18
0x4000.8000	0x4000.8FFF	SSI0	表 6-27
0x4000.9000	0x4000.9FFF	SSI1	表 6-27
0x4000.A000	0x4000.AFFF	SSI2	表 6-27
0x4000.B000	0x4000.BFFF	SSI3	表 6-27
0x4000.C000	0x4000.CFFF	UART0	表 6-32
0x4000.D000	0x4000.DFFF	UART1	表 6-32
0x4000.E000	0x4000.EFFF	UART2	表 6-32
0x4000.F000	0x4000.FFFF	UART3	表 6-32
0x4001.0000	0x4001.0FFF	UART4	表 6-32
0x4001.1000	0x4001.1FFF	UART5	表 6-32
0x4001.2000	0x4001.2FFF	UART6	表 6-32
0x4001.3000	0x4001.3FFF	UART7	表 6-32
0x4001.4000	0x4001.FFFF	Reserved	
0x4002.0000	0x4002.0FFF	I2C 0	表 6-21
0x4002.1000	0x4002.1FFF	I2C 1	表 6-21
0x4002.2000	0x4002.2FFF	I2C 2	表 6-21
0x4002.3000	0x4002.3FFF	I2C 3	表 6-21
0x4002.4000	0x4002.4FFF	GPIO Port E	表 6-18
0x4002.5000	0x4002.5FFF	GPIO Port F	表 6-18
0x4002.6000	0x4002.6FFF	GPIO Port G	表 6-18
0x4002.7000	0x4002.7FFF	GPIO Port H	表 6-18
0x4002.8000	0x4002.8FFF	PWM 0	表 6-25
0x4002.9000	0x4002.BFFF	Reserved	

**表 6-3. Memory Map (continued)**

START	END	DESCRIPTION	REGISTERS
0x4002.C000	0x4002.CFFF	QE10	表 6-26
0x4002.D000	0x4002.FFFF	Reserved	
0x4003.0000	0x4003.0FFF	16/32-bit Timer 0	表 6-19
0x4003.1000	0x4003.1FFF	16/32-bit Timer 1	表 6-19
0x4003.2000	0x4003.2FFF	16/32-bit Timer 2	表 6-19
0x4003.3000	0x4003.3FFF	16/32-bit Timer 3	表 6-19
0x4003.4000	0x4003.4FFF	16/32-bit Timer 4	表 6-19
0x4003.5000	0x4003.5FFF	16/32-bit Timer 5	表 6-19
0x4003.6000	0x4003.7FFF	Reserved	
0x4003.8000	0x4003.8FFF	ADC0	表 6-7
0x4003.9000	0x4003.9FFF	ADC1	表 6-7
0x4003.A000	0x4003.BFFF	Reserved	
0x4003.C000	0x4003.CFFF	Analog Comparator	表 6-9
0x4003.D000	0x4003.DFFF	GPIO Port J	表 6-18
0x4003.E000	0x4003.FFFF	Reserved	
0x4004.0000	0x4004.0FFF	CAN0 Controller	表 6-8
0x4004.1000	0x4004.1FFF	CAN1 Controller	表 6-8
0x4004.2000	0x4004.FFFF	Reserved	
0x4005.0000	0x4005.0FFF	USB	表 6-33
0x4005.1000	0x4005.7FFF	Reserved	
0x4005.8000	0x4005.8FFF	GPIO Port A (AHB aperture)	表 6-18
0x4005.9000	0x4005.9FFF	GPIO Port B (AHB aperture)	表 6-18
0x4005.A000	0x4005.AFFF	GPIO Port C (AHB aperture)	表 6-18
0x4005.B000	0x4005.BFFF	GPIO Port D (AHB aperture)	表 6-18
0x4005.C000	0x4005.CFFF	GPIO Port E (AHB aperture)	表 6-18
0x4005.D000	0x4005.DFFF	GPIO Port F (AHB aperture)	表 6-18
0x4005.E000	0x4005.EFFF	GPIO Port G (AHB aperture)	表 6-18
0x4005.F000	0x4005.FFFF	GPIO Port H (AHB aperture)	表 6-18
0x4006.0000	0x4006.0FFF	GPIO Port J (AHB aperture)	表 6-18
0x4006.1000	0x4006.1FFF	GPIO Port K (AHB aperture)	表 6-18
0x4006.2000	0x4006.2FFF	GPIO Port L (AHB aperture)	表 6-18
0x4006.3000	0x4006.3FFF	GPIO Port M (AHB aperture)	表 6-18
0x4006.4000	0x4006.4FFF	GPIO Port N (AHB aperture)	表 6-18
0x4006.5000	0x4006.5FFF	GPIO Port P (AHB aperture)	表 6-18
0x4006.6000	0x4006.6FFF	GPIO Port Q (AHB aperture)	表 6-18
0x4006.7000	0x4006.7FFF	GPIO Port R (AHB aperture)	表 6-18
0x4006.8000	0x4006.8FFF	GPIO Port S (AHB aperture)	表 6-18
0x4006.9000	0x4006.9FFF	GPIO Port T (AHB aperture)	表 6-18
0x4006.A000	0x400A.EFFF	Reserved	
0x400A.F000	0x400A.FFFF	EEPROM and Key Locker	表 6-13
0x400B.0000	0x400B.5FFF	Reserved	
0x400B.6000	0x400B.6FFF	1-Wire Master	表 6-4
0x400B.7000	0x400B.7FFF	Reserved	
0x400B.8000	0x400B.8FFF	I2C 8	表 6-21
0x400B.9000	0x400B.9FFF	I2C 9	表 6-21
0x400B.A000	0x400B.FFFF	Reserved	
0x400C.0000	0x400C.0FFF	I2C 4	表 6-21

表 6-3. Memory Map (continued)

START	END	DESCRIPTION	REGISTERS
0x400C.1000	0x400C.1FFF	I2C 5	表 6-21
0x400C.2000	0x400C.2FFF	I2C 6	表 6-21
0x400C.3000	0x400C.3FFF	I2C 7	表 6-21
0x400C.4000	0x400C.FFFF	Reserved	
0x400D.0000	0x400D.0FFF	EPI0	表 6-14
0x400D.1000	0x400D.FFFF	Reserved	
0x400E.0000	0x400E.0FFF	16/32-bit Timer 6	表 6-19
0x400E.1000	0x400E.1FFF	16/32-bit Timer 7	表 6-19
0x400E.2000	0x400E.BFFF	Reserved	
0x400E.C000	0x400E.CFFF	Ethernet Controller	表 6-15
0x400E.D000	0x400F.8FFF	Reserved	
0x400F.9000	0x400F.9FFF	System Exception	表 6-31
0x400F.A000	0x400F.BFFF	Reserved	
0x400F.C000	0x400F.CFFF	Hibernation	表 6-20
0x400F.D000	0x400F.DFFF	Flash Memory Control	表 6-17
0x400F.E000	0x400F.EFFF	System Control	表 6-30
0x400F.F000	0x400F.FFFF	μDMA	表 6-23
0x4010.0000	0x41FF.FFFF	Reserved	
0x4200.0000	0x43FF.FFFF	Bit-banded alias of 0x4000.0000 through 0x400F.FFFF	
0x4400.0000	0x4402.FFFF	Reserved	
0x4403.0000	0x4403.0FFF	CRC and Cryptographic Control	表 6-10
0x4403.1000	0x4403.1FFF	Reserved (4KB)	
0x4403.2000	0x4403.3FFF	Reserved (8KB)	
0x4403.4000	0x4403.5FFF	SHA/MD5	表 6-28
0x4403.6000	0x4403.7FFF	AES	表 6-5, 表 6-6
0x4403.8000	0x4403.9FFF	DES	表 6-11, 表 6-12
0x4403.A000	0x4403.EFFF	Reserved	
0x4403.F000	0x4403.FFFF	Reserved (4KB)	
0x4404.0000	0x4404.FFFF	Reserved (64KB)	
0x4405.0000	0x4405.0FFF	LCD	表 6-22
0x4405.1000	0x4405.3FFF	Reserved	
0x4405.4000	0x4405.4FFF	EPHY 0	表 6-16
0x4405.5000	0x5FFF.FFFF	Reserved	
0x6000.0000	0xDFFF.FFFF	EPI0 Mapped Peripheral and RAM	表 6-14

表 6-4. 1-Wire Master Registers

OFFSET	ACRONYM	REGISTER NAME
0x0	ONEWIRECS	1-Wire Control and Status
0x4	ONEWIRETIM	1-Wire Timing Override
0x8	ONEWIREDATW	1-Wire Data Write
0xC	ONEWIREDATR	1-Wire Data Read
0x100	ONEWIREIM	1-Wire Interrupt Mask
0x104	ONEWIRERIS	1-Wire Raw Interrupt Status
0x108	ONEWIREMIS	1-Wire Masked Interrupt Status
0x10C	ONEWIREICR	1-Wire Interrupt Clear
0x120	ONEWIREDMA	1-Wire μDMA Control
0xFC0	ONEWIREPP	1-Wire Peripheral Properties

**表 6-5. AES Registers**

OFFSET	ACRONYM	REGISTER NAME
0x00C	AES_KEY2_5	AES Key 2_5
0x010	AES_KEY2_2	AES Key 2_2
0x014	AES_KEY2_3	AES Key 2_3
0x018	AES_KEY2_0	AES Key 2_0
0x01C	AES_KEY2_1	AES Key 2_1
0x020	AES_KEY1_6	AES Key 1_6
0x024	AES_KEY1_7	AES Key 1_7
0x028	AES_KEY1_4	AES Key 1_4
0x02C	AES_KEY1_5	AES Key 1_5
0x030	AES_KEY1_2	AES Key 1_2
0x034	AES_KEY1_3	AES Key 1_3
0x038	AES_KEY1_0	AES Key 1_0
0x03C	AES_KEY1_1	AES Key 1_1
0x40 to 0x4C	AES_IV_IN_0 to AES_IV_IN_3	AES Initialization Vector Input 0 to AES Initialization Vector Input 3
0x50	AES_CTRL	AES Control
0x54 to 0x58	AES_C_LENGTH_0 to AES_C_LENGTH_1	AES Crypto Data Length 0 to AES Crypto Data Length 1
0x5C	AES_AUTH_LENGTH	AES Authentication Data Length
0x60 to 0x6C	AES_DATA_IN_0 to AES_DATA_IN_3	AES Data R/W Plaintext/Ciphertext 0 to AES Data R/W Plaintext/Ciphertext 3
0x70 to 0x7C	AES_TAG_OUT_0 to AES_TAG_OUT_3	AES Hash Tag Out 0 to AES Hash Tag Out 3
0x80	AES_REVISION	AES IP Revision Identifier
0x84	AES_SYSCONFIG	AES System Configuration
0x88	AES_SYSSTATUS	AES System Status
0x8C	AES_IRQSTATUS	AES Interrupt Status
0x90	AES_IRQENABLE	AES Interrupt Enable
0x94	AES_DIRTYBITS	AES Dirty Bits

**表 6-6. AES  $\mu$ DMA Registers**

OFFSET	ACRONYM	REGISTER NAME
0x20	AES_DMAIM	AES DMA Interrupt Mask
0x24	AES_DMARIS	AES DMA Raw Interrupt Status
0x28	AES_DMAMIS	AES DMA Masked Interrupt Status
0x2C	AES_DMAIC	AES DMA Interrupt Clear

**表 6-7. ADC Registers**

OFFSET	ACRONYM	REGISTER NAME
0x0	ADCACTSS	ADC Active Sample Sequencer
0x4	ADCRIS	ADC Raw Interrupt Status
0x8	ADCIM	ADC Interrupt Mask
0xC	ADCISC	ADC Interrupt Status and Clear
0x10	ADCOSTAT	ADC Overflow Status
0x14	ADCEMUX	ADC Event Multiplexer Select
0x18	ADCUSTAT	ADC Underflow Status
0x1C	ADCTSSEL	ADC Trigger Source Select
0x20	ADCSSPRI	ADC Sample Sequencer Priority

表 6-7. ADC Registers (continued)

OFFSET	ACRONYM	REGISTER NAME
0x24	ADCSPC	ADC Sample Phase Control
0x28	ADCPSSI	ADC Processor Sample Sequence Initiate
0x30	ADCSCAC	ADC Sample Averaging Control
0x34	ADCDCISC	ADC Digital Comparator Interrupt Status and Clear
0x38	ADCCTL	ADC Control
0x40	ADCSSMUX0	ADC Sample Sequence Input Multiplexer Select 0
0x44	ADCSSCTL0	ADC Sample Sequence Control 0
0x48	ADCSSFIFO0	ADC Sample Sequence Result FIFO 0
0x4C	ADCSSFSTAT0	ADC Sample Sequence FIFO 0 Status
0x50	ADCSSOP0	ADC Sample Sequence 0 Operation
0x54	ADCSSDC0	ADC Sample Sequence 0 Digital Comparator Select
0x58	ADCSEMUX0	ADC Sample Sequence Extended Input Multiplexer Select 0
0x5C	ADCSSSTSH0	ADC Sample Sequence 0 Sample and Hold Time
0x60	ADCSSMUX1	ADC Sample Sequence Input Multiplexer Select 1
0x64	ADCSSCTL1	ADC Sample Sequence Control 1
0x068	ADCSSFIFO1	ADC Sample Sequence Result FIFO 1
0x06C	ADCSSFSTAT1	ADC Sample Sequence FIFO 1 Status
0x70	ADCSSOP1	ADC Sample Sequence 1 Operation
0x74	ADCSSDC1	ADC Sample Sequence 1 Digital Comparator Select
0x78	ADCSEMUX1	ADC Sample Sequence Extended Input Multiplexer Select 1
0x7C	ADCSSSTSH1	ADC Sample Sequence 1 Sample and Hold Time
0x080	ADCSSMUX2	ADC Sample Sequence Input Multiplexer Select 2
0x084	ADCSSCTL2	ADC Sample Sequence Control 2
0x088	ADCSSFIFO2	ADC Sample Sequence Result FIFO 2
0x08C	ADCSSFSTAT2	ADC Sample Sequence FIFO 2 Status
0x090	ADCSSOP2	ADC Sample Sequence 2 Operation
0x094	ADCSSDC2	ADC Sample Sequence 2 Digital Comparator Select
0x098	ADCSEMUX2	ADC Sample Sequence Extended Input Multiplexer Select 2
0x09C	ADCSSSTSH2	ADC Sample Sequence 2 Sample and Hold Time
0xA0	ADCSSMUX3	ADC Sample Sequence Input Multiplexer Select 3
0xA4	ADCSSCTL3	ADC Sample Sequence Control 3
0x0A8	ADCSSFIFO3	ADC Sample Sequence Result FIFO 3
0x0AC	ADCSSFSTAT3	ADC Sample Sequence FIFO 3 Status
0xB0	ADCSSOP3	ADC Sample Sequence 3 Operation
0xB4	ADCSSDC3	ADC Sample Sequence 3 Digital Comparator Select
0xB8	ADCSEMUX3	ADC Sample Sequence Extended Input Multiplexer Select 3
0xBC	ADCSSSTSH3	ADC Sample Sequence 3 Sample and Hold Time
0xD00	ADCDCRIC	ADC Digital Comparator Reset Initial Conditions
0xE00 to 0xE1C	ADCDCCTL0 to ADCDCCTL7	ADC Digital Comparator Control 0 to ADC Digital Comparator Control 7
0xE40 to 0xE5C	ADCDCCMP0 to ADCDCCMP7	ADC Digital Comparator Range 0 to ADC Digital Comparator Range 7
0xFC0	ADCPP	ADC Peripheral Properties
0xFC4	ADCPC	ADC Peripheral Configuration
0xFC8	ADCCC	ADC Clock Configuration



**表 6-8. CAN Registers**

OFFSET	ACRONYM	REGISTER NAME
0x0	CANCTL	CAN Control
0x4	CANSTS	CAN Status
0x8	CANERR	CAN Error Counter
0xC	CANBIT	CAN Bit Timing
0x10	CANINT	CAN Interrupt
0x14	CANTST	CAN Test
0x18	CANBRPE	CAN Baud Rate Prescaler Extension
0x20	CANIF1CRQ	CAN IF1 Command Request
0x24	CANIF1CMSK	CAN IF1 Command Mask
0x28	CANIF1MSK1	CAN IF1 Mask 1
0x2C	CANIF1MSK2	CAN IF1 Mask 2
0x30	CANIF1ARB1	CAN IF1 Arbitration 1
0x34	CANIF1ARB2	CAN IF1 Arbitration 2
0x38	CANIF1MCTL	CAN IF1 Message Control
0x3C	CANIF1DA1	CAN IF1 Data A1
0x40	CANIF1DA2	CAN IF1 Data A2
0x44	CANIF1DB1	CAN IF1 Data B1
0x48	CANIF1DB2	CAN IF1 Data B2
0x80	CANIF2CRQ	CAN IF2 Command Request
0x84	CANIF2CMSK	CAN IF2 Command Mask
0x88	CANIF2MSK1	CAN IF2 Mask 1
0x8C	CANIF2MSK2	CAN IF2 Mask 2
0x90	CANIF2ARB1	CAN IF2 Arbitration 1
0x94	CANIF2ARB2	CAN IF2 Arbitration 2
0x98	CANIF2MCTL	CAN IF2 Message Control
0x9C	CANIF2DA1	CAN IF2 Data A1
0xA0	CANIF2DA2	CAN IF2 Data A2
0xA4	CANIF2DB1	CAN IF2 Data B1
0xA8	CANIF2DB2	CAN IF2 Data B2
0x100	CANTXRQ1	CAN Transmission Request 1
0x104	CANTXRQ2	CAN Transmission Request 2
0x120	CANNWDA1	CAN New Data 1
0x124	CANNWDA2	CAN New Data 2
0x140	CANMSG1INT	CAN Message 1 Interrupt Pending
0x144	CANMSG2INT	CAN Message 2 Interrupt Pending
0x160	CANMSG1VAL	CAN Message 1 Valid
0x164	CANMSG2VAL	CAN Message 2 Valid

**表 6-9. Comparator Registers**

OFFSET	ACRONYM	REGISTER NAME
0x0	ACMIS	Analog Comparator Masked Interrupt Status
0x4	ACRIS	Analog Comparator Raw Interrupt Status
0x8	ACINTEN	Analog Comparator Interrupt Enable
0x10	ACREFCTL	Analog Comparator Reference Voltage Control
0x20	ACSTAT0	Analog Comparator Status 0
0x24	ACCTL0	Analog Comparator Control 0
0x40	ACSTAT1	Analog Comparator Status 1

表 6-9. Comparator Registers (continued)

OFFSET	ACRONYM	REGISTER NAME
0x44	ACCTL1	Analog Comparator Control 1
0x60	ACSTAT2	Analog Comparator Status 2
0x64	ACCTL2	Analog Comparator Control 2
0xFC0	ACMPPP	Analog Comparator Peripheral Properties

表 6-10. CRC Registers

OFFSET	ACRONYM	REGISTER NAME
400h	CRCCTRL	CRC Control
410h	CRCSEED	CRC SEED/Context
414h	CRC DIN	CRC Data Input
418h	CRCRSLTPP	CRC Post Processing Result

表 6-11. DES Registers

OFFSET	ACRONYM	REGISTER NAME
0x00	DES_KEY3_L	DES Key 3 LSW for 192-Bit Key
0x04	DES_KEY3_H	DES Key 3 MSW for 192-Bit Key
0x08	DES_KEY2_L	DES Key 2 LSW for 128-Bit Key
0x0C	DES_KEY2_H	DES Key 2 MSW for 128-Bit Key
0x10	DES_KEY1_L	DES Key 1 LSW for 64-Bit Key
0x14	DES_KEY1_H	DES Key 1 MSW for 64-Bit Key
0x18	DES_IV_L	DES Initialization Vector
0x1C	DES_IV_H	DES Initialization Vector
0x20	DES_CTRL	DES Control
0x24	DES_LENGTH	DES Cryptographic Data Length
0x28	DES_DATA_L	DES LSW Data RW
0x2C	DES_DATA_H	DES MSW Data RW
0x30	DES_REVISION	DES Revision Number
0x34	DES_SYSCONFIG	DES System Configuration
0x38	DES_SYSSTATUS	DES System Status
0x3C	DES_IRQSTATUS	DES Interrupt Status
0x40	DES_IRQENABLE	DES Interrupt Enable
0x44	DES_DIRTYBITS	DES Dirty Bits

表 6-12. DES  $\mu$ DMA Registers

OFFSET	ACRONYM	REGISTER NAME
0x30	DES_DMAIM	DES DMA Interrupt Mask
0x34	DES_DMARIS	DES DMA Raw Interrupt Status
0x38	DES_DMAMIS	DES DMA Masked Interrupt Status
0x3C	DES_DMAIC	DES DMA Interrupt Clear

表 6-13. EEPROM Registers

OFFSET	ACRONYM	REGISTER NAME
0x0	EESIZE	EEPROM Size Information
0x4	EEBLOCK	EEPROM Current Block
0x8	EEOFFSET	EEPROM Current Offset
0x10	EERDWR	EEPROM Read-Write

**表 6-13. EEPROM Registers (continued)**

OFFSET	ACRONYM	REGISTER NAME
0x14	EERDWRINC	EEPROM Read-Write with Increment
0x18	EEDONE	EEPROM Done Status
0x1C	EESUPP	EEPROM Support Control and Status
0x20	EEUNLOCK	EEPROM Unlock
0x30	EEPROT	EEPROM Protection
0x34 to 0x3C	EEPASS0 to EEPASS2	EEPROM Password 0 to EEPROM Password 2
0x40	EEINT	EEPROM Interrupt
0x50	EEHIDE0	EEPROM Block Hide 0
0x54	EEHIDE1	EEPROM Block Hide 1
0x58	EEHIDE2	EEPROM Block Hide 2
0x80	EEDBGME	EEPROM Debug Mass Erase
0xFC0	EEPROMPP	EEPROM Peripheral Properties

**表 6-14. EPI Registers**

OFFSET	ACRONYM	REGISTER NAME
0x000	EPICFG	EPI Configuration
0x004	EPIBAUD	EPI Main Baud Rate
0x008	EPIBAUD2	EPI Main Baud Rate
0x010	EPISDRAMCFG	EPI SDRAM Configuration
0x010	EPIHB8CFG	EPI Host-Bus 8 Configuration
0x010	EPIHB16CFG	EPI Host-Bus 16 Configuration
0x010	EPIGPCFG	EPI General-Purpose Configuration
0x014	EPIHB8CFG2	EPI Host-Bus 8 Configuration 2
0x014	EPIHB16CFG2	EPI Host-Bus 16 Configuration 2
0x01C	EPIADDRMAP	EPI Address Map
0x020	EPIRSIZE0	EPI Read Size 0
0x024	EPIRADDR0	EPI Read Address 0
0x028	EPIRPSTD0	EPI Non-Blocking Read Data 0
0x030	EPIRSIZE1	EPI Read Size 1
0x034	EPIRADDR1	EPI Read Address 1
0x038	EPIRPSTD1	EPI Non-Blocking Read Data 1
0x060	EPISTAT	EPI Status
0x06C	EPIRFIFOCNT	EPI Read FIFO Count
0x70 to 0x8C	EPIREADFIFO0 to EPIREADFIFO7	EPI Read FIFO 0 to EPI Read FIFO 7
0x200	EPIFIFOLVL	EPI FIFO Level Selects
0x24	EPIWFIFOCNT	EPI Write FIFO Count
0x28	EPIDMATXCNT	EPI DMA Transmit Count
0x210	EPIIM	EPI Interrupt Mask
0x214	EPIRIS	EPI Raw Interrupt Status
0x218	EPIMIS	EPI Masked Interrupt Status
0x21C	EPIEISC	EPI Error and Interrupt Status and Clear
0x308	EPIHB8CFG3	EPI Host-Bus 8 Configuration 3
0x308	EPIHB16CFG3	EPI Host-Bus 16 Configuration 3
0x30C	EPIHB8CFG4	EPI Host-Bus 8 Configuration 4
0x30C	EPIHB16CFG4	EPI Host-Bus 16 Configuration 4
0x310	EPIHB8TIME	EPI Host-Bus 8 Timing Extension
0x310	EPIHB16TIME	EPI Host-Bus 16 Timing Extension

表 6-14. EPI Registers (continued)

OFFSET	ACRONYM	REGISTER NAME
0x314	EPIHB8TIME2	EPI Host-Bus 8 Timing Extension
0x314	EPIHB16TIME2	EPI Host-Bus 16 Timing Extension
0x318	EPIHB8TIME3	EPI Host-Bus 8 Timing Extension
0x318	EPIHB16TIME3	EPI Host-Bus 16 Timing Extension
0x31C	EPIHB8TIME4	EPI Host-Bus 8 Timing Extension
0x31C	EPIHB16TIME4	EPI Host-Bus 16 Timing Extension
0x360	EPIHBPSRAM	EPI Host-Bus PSRAM

表 6-15. Ethernet MAC (EMAC) Registers

OFFSET	ACRONYM	REGISTER NAME
0x0	EMACCFG	Ethernet MAC Configuration
0x4	EMACFRAMEFLTR	Ethernet MAC Frame Filter
0x8	EMACHASHTBLH	Ethernet MAC Hash Table High
0xC	EMACHASHTBLL	Ethernet MAC Hash Table Low
0x10	EMACMIIADDR	Ethernet MAC MII Address
0x14	EMACMIIDATA	Ethernet MAC MII Data Register
0x18	EMACFLOWCTL	Ethernet MAC Flow Control
0x1C	EMACVLANTG	Ethernet MAC VLAN Tag
0x24	EMACSTATUS	Ethernet MAC Status
0x28	EMACRWUFF	Ethernet MAC Remote Wake-Up Frame Filter
0x2C	EMACPMCTLSTAT	Ethernet MAC PMT Control and Status
0x30	EMACLPICTLSTAT	LPI Control and Status
0x34	EMACLPIIMERCTRL	LPI Timers Control
0x38	EMACRIS	Ethernet MAC Raw Interrupt Status
0x3C	EMACIM	Ethernet MAC Interrupt Mask
0x40	EMACADDR0H	Ethernet MAC Address 0 High
0x44	EMACADDR0L	Ethernet MAC Address 0 Low Register
0x48	EMACADDR1H	Ethernet MAC Address 1 High
0x4C	EMACADDR1L	Ethernet MAC Address 1 Low
0x50	EMACADDR2H	Ethernet MAC Address 2 High
0x54	EMACADDR2L	Ethernet MAC Address 2 Low
0x58	EMACADDR3H	Ethernet MAC Address 3 High
0x5C	EMACADDR3L	Ethernet MAC Address 3 Low
0xDC	EMACWDOGTO	Ethernet MAC Watchdog Time-out
0x100	EMACMMCCTRL	Ethernet MAC MMC Control
0x104	EMACMMCRXRIS	Ethernet MAC MMC Receive Raw Interrupt Status
0x108	EMACMMCTXRIS	Ethernet MAC MMC Transmit Raw Interrupt Status
0x10C	EMACMMCRXIM	Ethernet MAC MMC Receive Interrupt Mask
0x110	EMACMMCTXIM	Ethernet MAC MMC Transmit Interrupt Mask
0x118	EMACTXCNTGB	Ethernet MAC Transmit Frame Count for Good and Bad Frames
0x14C	EMACTXCNTSCOL	Ethernet MAC Transmit Frame Count for Frames Transmitted After Single Collision
0x150	EMACTXCNTMCOL	Ethernet MAC Transmit Frame Count for Frames Transmitted After Multiple Collisions
0x164	EMACTXOCTCNTG	Ethernet MAC Transmit Octet Count Good
0x180	EMACRXCNTGB	Ethernet MAC Receive Frame Count for Good and Bad Frames
0x194	EMACRXCNTCRCERR	Ethernet MAC Receive Frame Count for CRC Error Frames
0x198	EMACRXCNTALGNERR	Ethernet MAC Receive Frame Count for Alignment Error Frames

**表 6-15. Ethernet MAC (EMAC) Registers (continued)**

OFFSET	ACRONYM	REGISTER NAME
0x1C4	EMACRXCNTGUNI	Ethernet MAC Receive Frame Count for Good Unicast Frames
0x584	EMACVLNINCREP	Ethernet MAC VLAN Tag Inclusion or Replacement
0x588	EMACVLANHASH	Ethernet MAC VLAN Hash Table
0x700	EMACTIMSTCTRL	Ethernet MAC Timestamp Control
0x704	EMACSUBSECINC	Ethernet MAC Sub-Second Increment
0x708	EMACTIMSEC	Ethernet MAC System Time - Seconds
0x70C	EMACTIMNANO	Ethernet MAC System Time - Nanoseconds
0x710	EMACTIMSECU	Ethernet MAC System Time - Seconds Update
0x714	EMACTIMNANOOU	Ethernet MAC System Time - Nanoseconds Update
0x718	EMACTIMADD	Ethernet MAC Timestamp Addend
0x71C	EMACTARGSEC	Ethernet MAC Target Time Seconds
0x720	EMACTARGNANO	Ethernet MAC Target Time Nanoseconds
0x724	EMACHWORDSEC	Ethernet MAC System Time-Higher Word Seconds
0x728	EMACTIMSTAT	Ethernet MAC Timestamp Status
0x72C	EMACPPSCTRL	Ethernet MAC PPS Control
0x760	EMACPPS0INTVL	Ethernet MAC PPS0 Interval
0x764	EMACPPS0WIDTH	Ethernet MAC PPS0 Width
0xC00	EMACDMABUSMOD	Ethernet MAC DMA Bus Mode
0xC04	EMACTXPOLL	Ethernet MAC Transmit Poll Demand
0xC08	EMACRXPOLLD	Ethernet MAC Receive Poll Demand
0xC0C	EMACRXDLADDR	Ethernet MAC Receive Descriptor List Address
0xC10	EMACTXDLADDR	Ethernet MAC Transmit Descriptor List Address
0xC14	EMACDMARIS	Ethernet MAC DMA Interrupt Status
0xC18	EMACDMAOPMODE	Ethernet MAC DMA Operation Mode
0xC1C	EMACDMAIM	Ethernet MAC DMA Interrupt Mask Register
0xC20	EMACMFB0C	Ethernet MAC Missed Frame and Buffer Overflow Counter
0xC24	EMACRXINTWDT	Ethernet MAC Receive Interrupt Watchdog Timer
0xC48	EMACHOSTXDESC	Ethernet MAC Current Host Transmit Descriptor
0xC4C	EMACHOSRXDESC	Ethernet MAC Current Host Receive Descriptor
0xC50	EMACHOSTXBA	Ethernet MAC Current Host Transmit Buffer Address
0xC54	EMACHOSRXBA	Ethernet MAC Current Host Receive Buffer Address
0xFC0	EMACPP	Ethernet MAC Peripheral Property Register
0xFC4	EMACPC	Ethernet MAC Peripheral Configuration
0xFC8	EMACCC	Ethernet MAC Clock Configuration
0xFD0	EPHYRIS	Ethernet PHY Raw Interrupt Status
0xFD4	EPHYIM	Ethernet PHY Interrupt Mask
0xFD8	EPHYMISC	Ethernet PHY Masked Interrupt Status and Clear

**表 6-16. Ethernet MII Management (EPHY) Registers (Accessed Through the EMACMIIADDR Register)**

ADDRESS	ACRONYM	REGISTER NAME
0x00	EPHYBMCR	Ethernet PHY Basic Mode Control - MR0
0x01	EPHYBMSR	Ethernet PHY Basic Mode Status - MR1
0x02	EPHYID1	Ethernet PHY Identifier Register 1 - MR2
0x03	EPHYID2	Ethernet PHY Identifier Register 2 - MR3
0x04	EPHYANA	Ethernet PHY Auto-Negotiation Advertisement - MR4
0x05	EPHYANLPA	Ethernet PHY Auto-Negotiation Link Partner Ability -MR5
0x06	EPHYANER	Ethernet PHY Auto-Negotiation Expansion - MR6

**表 6-16. Ethernet MII Management (EPHY) Registers (Accessed Through the EMACMIIADDR Register) (continued)**

ADDRESS	ACRONYM	REGISTER NAME
0x07	EPHYANNPTR	Ethernet PHY Auto-Negotiation Next Page TX - MR7
0x08	EPHYANLNPTR	Ethernet PHY Auto-Negotiation Link Partner Ability Next Page - MR8
0x09	EPHYCFG1	Ethernet PHY Configuration 1 - MR9
0x0A	EPHYCFG2	Ethernet PHY Configuration 2 - MR10
0x0B	EPHYCFG3	Ethernet PHY Configuration 3 - MR11
0x0D	EPHYREGCTL	Ethernet PHY Register Control - MR13
0x0E	EPHYADDAR	Ethernet PHY Address or Data - MR14
0x10	EPHYSTS	Ethernet PHY Status - MR16
0x11	EPHYSCR	Ethernet PHY Specific Control - MR17
0x12	EPHYMISR1	Ethernet PHY MII Interrupt Status 1 - MR18
0x13	EPHYMISR2	Ethernet PHY MII Interrupt Status 2 - MR19
0x14	EPHYFCSCR	Ethernet PHY False Carrier Sense Counter - MR20
0x15	EPHYRXERCNT	Ethernet PHY Receive Error Count - MR21
0x16	EPHYBISTCR	Ethernet PHY BIST Control - MR22
0x18	EPHYLEDCR	Ethernet PHY LED Control - MR24
0x19	EPHYCTL	Ethernet PHY Control - MR25
0x1A	EPHY10BTSC	Ethernet PHY 10Base-T Status/Control - MR26
0x1B	EPHYBICSR1	Ethernet PHY BIST Control and Status 1 - MR27
0x1C	EPHYBICSR2	Ethernet PHY BIST Control and Status 2 - MR28
0x1E	EPHYCDCR	Ethernet PHY Cable Diagnostic Control - MR30
0x1F	EPHYRCR	Ethernet PHY Reset Control - MR31
0x25	EPHYLEDCFG	Ethernet PHY LED Configuration - MR37

**表 6-17. Flash Registers**

OFFSET	ACRONYM	REGISTER NAME
0x0	FMA	Flash Memory Address
0x4	FMD	Flash Memory Data
0x8	FMC	Flash Memory Control
0xC	FCRIS	Flash Controller Raw Interrupt Status
0x10	FCIM	Flash Controller Interrupt Mask
0x14	FCMISC	Flash Controller Masked Interrupt Status and Clear
0x20	FMC2	Flash Memory Control 2
0x30	FWBVAL	Flash Write Buffer Valid
0x3C	FLPEKEY	Flash Program/Erase Key
0x100 to 0x17C	FWB0 to FWB31	Flash Write Buffer 0 to Flash Write Buffer 32
0xFC0	FLASHPP	Flash Peripheral Properties
0xFC4	SSIZE	SRAM Size
0xFC8	FLASHCONF	Flash Configuration Register
0xFCC	ROMSWMAP	ROM Third-Party Software
0xFD0	FLASHDMASZ	Flash DMA Address Size
0xFD4	FLASHDMAST	Flash DMA Starting Address

**表 6-18. GPIO Registers**

OFFSET	ACRONYM	REGISTER NAME
0x0	GPIONDATA	GPIO Data
0x400	GPIONDIR	GPIO Direction

**表 6-18. GPIO Registers (continued)**

OFFSET	ACRONYM	REGISTER NAME
0x404	GPIOIS	GPIO Interrupt Sense
0x408	GPIOIBE	GPIO Interrupt Both Edges
0x40C	GPIOIEV	GPIO Interrupt Event
0x410	GPIOIM	GPIO Interrupt Mask
0x414	GPIOIRIS	GPIO Raw Interrupt Status
0x418	GIPIOMIS	GPIO Masked Interrupt Status
0x41C	GPIOICR	GPIO Interrupt Clear
0x420	GPIOAFSEL	GPIO Alternate Function Select
0x500	GPIODR2R	GPIO 2-mA Drive Select
0x504	GPIODR4R	GPIO 4-mA Drive Select
0x508	GPIODR8R	GPIO 8-mA Drive Select
0x50C	GPIOODR	GPIO Open Drain Select
0x510	GPIOPUR	GPIO Pullup Select
0x514	GPIOPDR	GPIO Pulldown Select
0x518	GPIOSLR	GPIO Slew Rate Control Select
0x51C	GIPIODEN	GPIO Digital Enable
0x520	GPIOLOCK	GPIO Lock
0x524	GPIOCR	GPIO Commit
0x528	GPIOAMSEL	GPIO Analog Mode Select
0x52C	GPIOPCTL	GPIO Port Control
0x530	GPIOADCCTL	GPIO ADC Control
0x534	GIPIODMACTL	GPIO DMA Control
0x538	GPIOSSI	GPIO Select Interrupt
0x53C	GPIODR12R	GPIO 12-mA Drive Select
0x540	GPIOWAKEPEN	GPIO Wake Pin Enable
0x544	GPIOWAKELVL	GPIO Wake Level
0x548	GPIOWAKESTAT	GPIO Wake Status
0xFC0	GPIOPP	GPIO Peripheral Property
0xFC4	GPIOPC	GPIO Peripheral Configuration
0xFD0	GPIOPeriphID4	GPIO Peripheral Identification 4
0xFD4	GPIOPeriphID5	GPIO Peripheral Identification 5
0xFD8	GPIOPeriphID6	GPIO Peripheral Identification 6
0xFDC	GPIOPeriphID7	GPIO Peripheral Identification 7
0xFE0	GPIOPeriphID0	GPIO Peripheral Identification 0
0xFE4	GPIOPeriphID1	GPIO Peripheral Identification 1
0xFE8	GPIOPeriphID2	GPIO Peripheral Identification 2
0xFEC	GPIOPeriphID3	GPIO Peripheral Identification 3
0xFF0	GPIOPCellID0	GPIO PrimeCell Identification 0
0xFF4	GPIOPCellID1	GPIO PrimeCell Identification 1
0xFF8	GPIOPCellID2	GPIO PrimeCell Identification 2
0xFFC	GPIOPCellID3	GPIO PrimeCell Identification 3

**表 6-19. GPTM Registers**

OFFSET	ACRONYM	REGISTER NAME
0x0	GPTMCFG	GPTM Configuration
0x4	GPTMTAMR	GPTM Timer A Mode
0x8	GPTMTBMR	GPTM Timer B Mode

表 6-19. GPTM Registers (continued)

OFFSET	ACRONYM	REGISTER NAME
0xC	GPTMCTL	GPTM Control
0x10	GPTMSYNC	GPTM Synchronize
0x18	GPTMIMR	GPTM Interrupt Mask
0x1C	GPTMRIS	GPTM Raw Interrupt Status
0x20	GPTMMIS	GPTM Masked Interrupt Status
0x24	GPTMICR	GPTM Interrupt Clear
0x28	GPTMTAILR	GPTM Timer A Interval Load
0x2C	GPTMTBILR	GPTM Timer B Interval Load
0x30	GPTMTAMATCHR	GPTM Timer A Match
0x34	GPTMTBMATCHR	GPTM Timer B Match
0x38	GPTMTAPR	GPTM Timer A Prescale
0x3C	GPTMTBPR	GPTM Timer B Prescale
0x40	GPTMTAPMR	GPTM TimerA Prescale Match
0x44	GPTMTBPMR	GPTM TimerB Prescale Match
0x48	GPTMTAR	GPTM Timer A
0x4C	GPTMTBR	GPTM Timer B
0x50	GPTMTAV	GPTM Timer A Value
0x54	GPTMTBV	GPTM Timer B Value
0x58	GPTMRTCPD	GPTM RTC Predivide
0x5C	GPTMTAPS	GPTM Timer A Prescale Snapshot
0x60	GPTMTBPS	GPTM Timer B Prescale Snapshot
0x6C	GPTMDMAEV	GPTM DMA Event
0x70	GPTMADCEV	GPTM ADC Event
0xFC0	GPTMPP	GPTM Peripheral Properties
0xFC8	GPTMCC	GPTM Clock Configuration

表 6-20. HIB Registers

OFFSET	ACRONYM	REGISTER NAME
0x0	HIBRTCC	Hibernation RTC Counter
0x4	HIBRTCM0	Hibernation RTC Match 0
0xC	HIBRTCLD	Hibernation RTC Load
0x10	HIBCTL	Hibernation Control
0x14	HIBIM	Hibernation Interrupt Mask
0x18	HIBRIS	Hibernation Raw Interrupt Status
0x1C	HIBMIS	Hibernation Masked Interrupt Status
0x20	HIBIC	Hibernation Interrupt Clear
0x24	HIBRTCT	Hibernation RTC Trim
0x28	HIBRTCSS	Hibernation RTC Sub Seconds
0x2C	HIBIO	Hibernation IO Configuration
0x30 to 0x6F	HIBDATA	Hibernation Data
0x300	HIBCALCTL	Hibernation Calendar Control
0x310	HIBCAL0	Hibernation Calendar 0
0x314	HIBCAL1	Hibernation Calendar 1
0x320	HIBCALLD0	Hibernation Calendar Load 0
0x324	HIBCALLD1	Hibernation Calendar Load 1
0x330	HIBCALM0	Hibernation Calendar Match 0
0x334	HIBCALM1	Hibernation Calendar Match 1



**表 6-20. HIB Registers (continued)**

OFFSET	ACRONYM	REGISTER NAME
0x360	HIBLOCK	Hibernation Lock
0x400	HIBTPCTL	HIB Tamper Control
0x404	HIBTPSTAT	HIB Tamper Status
0x410	HIBTPIO	HIB Tamper I/O Control
0x4E0	HIBTPLOG0	HIB Tamper Log 0
0x4E4	HIBTPLOG1	HIB Tamper Log 1
0x4E8	HIBTPLOG2	HIB Tamper Log 2
0x4EC	HIBTPLOG3	HIB Tamper Log 3
0x4F0	HIBTPLOG4	HIB Tamper Log 4
0x4F4	HIBTPLOG5	HIB Tamper Log 5
0x4F8	HIBTPLOG6	HIB Tamper Log 6
0x4FC	HIBTPLOG7	HIB Tamper Log 7
0xFC0	HIBPP	Hibernation Peripheral Properties
0xFC8	HIBCC	Hibernation Clock Control

**表 6-21. I2C Registers**

OFFSET	ACRONYM	REGISTER NAME
0x0	I2CMSA	I2C Master Slave Address
0x4	I2CMCS	I2C Master Control/Status
0x8	I2CMDR	I2C Master Data
0xC	I2CMTPR	I2C Master Timer Period
0x10	I2CMIMR	I2C Master Interrupt Mask
0x14	I2CMRIS	I2C Master Raw Interrupt Status
0x18	I2CMMIS	I2C Master Masked Interrupt Status
0x1C	I2CMICR	I2C Master Interrupt Clear
0x20	I2CMCR	I2C Master Configuration
0x24	I2CMCLKOCNT	I2C Master Clock Low Time-out Count
0x2C	I2CMBMON	I2C Master Bus Monitor
0x30	I2CMBLEN	I2C Master Burst Length
0x34	I2CMBCNT	I2C Master Burst Count
0x800	I2CSOAR	I2C Slave Own Address
0x804	I2CSCSR	I2C Slave Control/Status
0x808	I2CSDR	I2C Slave Data
0x80C	I2CSIMR	I2C Slave Interrupt Mask
0x810	I2CSRIS	I2C Slave Raw Interrupt Status
0x814	I2CSMIS	I2C Slave Masked Interrupt Status
0x818	I2CSICR	I2C Slave Interrupt Clear
0x81C	I2CSOAR2	I2C Slave Own Address 2
0x820	I2CSACKCTL	I2C Slave ACK Control
0xF00	I2CFIFODATA	I2C FIFO Data
0xF04	I2CFIFOCTL	I2C FIFO Control
0xF08	I2CFIFOSTATUS	I2C FIFO Status
0xFC0	I2CPP	I2C Peripheral Properties
0xFC4	I2CPC	I2C Peripheral Configuration

表 6-22. LCD Registers

OFFSET	ACRONYM	REGISTER NAME
0x0	LCDPID	LCD PID Register Format
0x4	LCDCTL	LCD Control
0xC	LCDLIDDCTL	LCD LIDD Control
0x10	LIDDCS0CFG	LCD LIDD CS0 Configuration
0x14	LIDDCS0ADDR	LIDD CS0 Read/Write Address
0x18	LIDDCS0DATA	LIDD CS0 Data Read/Write Initiation
0x1C	LIDDCS1CFG	LIDD CS1 Configuration
0x20	LIDDCS1ADDR	LIDD CS1 Address Read/Write Initiation
0x24	LIDDCS1DATA	LIDD CS1 Data Read/Write Initiation
0x28	LCDRASTRCTL	LCD Raster Control
0x2C	LCDRASTRTIM0	LCD Raster Timing 0
0x30	LCDRASTRTIM1	LCD Raster Timing 1
0x34	LCDRASTRTIM2	LCD Raster Timing 2
0x38	LCDRASTRSUBP1	LCD Raster Subpanel Display 1
0x3C	LCDRASTRSUBP2	LCD Raster Subpanel Display 2
0x40	LCDDMACTL	LCD DMA Control
0x44	LCDDMABAFB0	LCD DMA Frame Buffer 0 Base Address
0x48	LCDDMACAFB0	LCD DMA Frame Buffer 0 Ceiling Address
0x4C	LCDDMABAFB1	LCD DMA Frame Buffer 1 Base Address
0x50	LCDDMACAFB1	LCD DMA Frame Buffer 1 Ceiling Address
0x54	LCDSYSCFG	LCD System Configuration Register
0x58	LCDRISSET	LCD Interrupt Raw Status and Set Register
0x5C	LCDMISCLR	LCD Interrupt Status and Clear
0x60	LCDIM	LCD Interrupt Mask
0x64	LCDIENC	LCD Interrupt Enable Clear
0x6C	LCDCLKEN	LCD Clock Enable
0x70	LCDCLKRESET	LCD Clock Resets

表 6-23.  $\mu$ DMA Registers

OFFSET	ACRONYM	REGISTER NAME
0x0	DMASTAT	DMA Status
0x4	DMACFG	DMA Configuration
0x8	DMACTLBASE	DMA Channel Control Base Pointer
0xC	DMAALTBASE	DMA Alternate Channel Control Base Pointer
0x10	DMAWAITSTAT	DMA Channel Wait-on-Request Status
0x14	DMAWREQ	DMA Channel Software Request
0x18	DMAUSEBURSTSET	DMA Channel Useburst Set
0x1C	DMAUSEBURSTCLR	DMA Channel Useburst Clear
0x20	DMAREQMASKSET	DMA Channel Request Mask Set
0x24	DMAREQMASKCLR	DMA Channel Request Mask Clear
0x28	DMAENASET	DMA Channel Enable Set
0x2C	DMAENACLAR	DMA Channel Enable Clear
0x30	DMAALTSET	DMA Channel Primary Alternate Set
0x34	DMAALTCLR	DMA Channel Primary Alternate Clear
0x38	DMAPRIOSET	DMA Channel Priority Set
0x3C	DMAPRIOCLR	DMA Channel Priority Clear
0x4C	DMAERRCLR	DMA Bus Error Clear

**表 6-23.  $\mu$ DMA Registers (continued)**

OFFSET	ACRONYM	REGISTER NAME
0x510	DMACHMAP0	DMA Channel Map Select 0
0x514	DMACHMAP1	DMA Channel Map Select 1
0x518	DMACHMAP2	DMA Channel Map Select 2
0x51C	DMACHMAP3	DMA Channel Map Select 3
0xFD0	DMAPeriphID4	DMA Peripheral Identification 4
0xFE0	DMAPeriphID0	DMA Peripheral Identification 0
0xFE4	DMAPeriphID1	DMA Peripheral Identification 1
0xFE8	DMAPeriphID2	DMA Peripheral Identification 2
0xFEC	DMAPeriphID3	DMA Peripheral Identification 3
0xFF0	DMAPrimeCellID0	DMA PrimeCell Identification 0
0xFF4	DMAPrimeCellID1	DMA PrimeCell Identification 1
0xFF8	DMAPrimeCellID2	DMA PrimeCell Identification 2
0xFFC	DMAPrimeCellID3	DMA PrimeCell Identification 3

**表 6-24.  $\mu$ DMA Channel Control Structure Registers**

OFFSET	ACRONYM	REGISTER NAME
0x0	DMASRCENDP	DMA Channel Source Address End Pointer
0x4	DMADSTENDP	DMA Channel Destination Address End Pointer
0x8	DMACHCTL	DMA Channel Control Word

**表 6-25. PWM Registers**

OFFSET	ACRONYM	REGISTER NAME
0x0	PWMCTL	PWM Master Control
0x4	PWMSYNC	PWM Time Base Sync
0x8	PWMENABLE	PWM Output Enable
0xC	PWMINVERT	PWM Output Inversion
0x10	PWMFAULT	PWM Output Fault
0x14	PWMINTEN	PWM Interrupt Enable
0x18	PWMRIS	PWM Raw Interrupt Status
0x1C	PWMISC	PWM Interrupt Status and Clear
0x20	PWMSTATUS	PWM Status
0x24	PWMFAULTVAL	PWM Fault Condition Value
0x28	PWMENUPD	PWM Enable Update
0x40	PWM0CTL	PWM0 Control
0x44	PWM0INTEN	PWM0 Interrupt and Trigger Enable
0x48	PWM0RIS	PWM0 Raw Interrupt Status
0x4C	PWM0ISC	PWM0 Interrupt Status and Clear
0x50	PWM0LOAD	PWM0 Load
0x54	PWM0COUNT	PWM0 Counter
0x58	PWM0CMPA	PWM0 Compare A
0x5C	PWM0CMPB	PWM0 Compare B
0x60	PWM0GENA	PWM0 Generator A Control
0x64	PWM0GENB	PWM0 Generator B Control
0x68	PWM0DBCTL	PWM0 Dead-Band Control
0x6C	PWM0DBRISE	PWM0 Dead-Band Rising-Edge Delay
0x70	PWM0DBFALL	PWM0 Dead-Band Falling-Edge-Delay
0x74	PWM0FLTSRC0	PWM0 Fault Source 0

表 6-25. PWM Registers (continued)

OFFSET	ACRONYM	REGISTER NAME
0x78	PWM0FLTSRC1	PWM0 Fault Source 1
0x7C	PWM0MINFLTPER	PWM0 Minimum Fault Period
0x080	PWM1CTL	PWM1 Control
0x084	PWM1INTEN	PWM1 Interrupt and Trigger Enable
0x088	PWM1RIS	PWM1 Raw Interrupt Status
0x08C	PWM1ISC	PWM1 Interrupt Status and Clear
0x090	PWM1LOAD	PWM1 Load
0x094	PWM1COUNT	PWM1 Counter
0x098	PWM1CMPA	PWM1 Compare A
0x09C	PWM1CMPB	PWM1 Compare B
0x0A0	PWM1GENA	PWM1 Generator A Control
0x0A4	PWM1GENB	PWM1 Generator B Control
0x0A8	PWM1DBCTL	PWM1 Dead-Band Control
0x0AC	PWM1DBRISE	PWM1 Dead-Band Rising-Edge Delay
0x0B0	PWM1DBFALL	PWM1 Dead-Band Falling-Edge-Delay
0x0B4	PWM1FLTSRC0	PWM1 Fault Source 0
0x0B8	PWM1FLTSRC1	PWM1 Fault Source 1
0x0BC	PWM1MINFLTPER	PWM1 Minimum Fault Period
0x0C0	PWM2CTL	PWM2 Control
0x0C4	PWM2INTEN	PWM2 Interrupt and Trigger Enable
0x0C8	PWM2RIS	PWM2 Raw Interrupt Status
0x0CC	PWM2ISC	PWM2 Interrupt Status and Clear
0x0D0	PWM2LOAD	PWM2 Load
0x0D4	PWM2COUNT	PWM2 Counter
0x0D8	PWM2CMPA	PWM2 Compare A
0x0DC	PWM2CMPB	PWM2 Compare B
0x0E0	PWM2GENA	PWM2 Generator A Control
0x0E4	PWM2GENB	PWM2 Generator B Control
0x0E8	PWM2DBCTL	PWM2 Dead-Band Control
0x0EC	PWM2DBRISE	PWM2 Dead-Band Rising-Edge Delay
0x0F0	PWM2DBFALL	PWM2 Dead-Band Falling-Edge-Delay
0x0F4	PWM2FLTSRC0	PWM2 Fault Source 0
0x0F8	PWM2FLTSRC1	PWM2 Fault Source 1
0x0FC	PWM2MINFLTPER	PWM2 Minimum Fault Period
0x100	PWM3CTL	PWM3 Control
0x104	PWM3INTEN	PWM3 Interrupt and Trigger Enable
0x108	PWM3RIS	PWM3 Raw Interrupt Status
0x10C	PWM3ISC	PWM3 Interrupt Status and Clear
0x110	PWM3LOAD	PWM3 Load
0x114	PWM3COUNT	PWM3 Counter
0x118	PWM3CMPA	PWM3 Compare A
0x11C	PWM3CMPB	PWM3 Compare B
0x120	PWM3GENA	PWM3 Generator A Control
0x124	PWM3GENB	PWM3 Generator B Control
0x128	PWM3DBCTL	PWM3 Dead-Band Control
0x12C	PWM3DBRISE	PWM3 Dead-Band Rising-Edge Delay
0x130	PWM3DBFALL	PWM3 Dead-Band Falling-Edge-Delay

**表 6-25. PWM Registers (continued)**

OFFSET	ACRONYM	REGISTER NAME
0x134	PWM3FLTSRC0	PWM3 Fault Source 0
0x138	PWM3FLTSRC1	PWM3 Fault Source 1
0x13C	PWM3MINFLTPER	PWM3 Minimum Fault Period
0x800	PWM0FLTSEN	PWM0 Fault Pin Logic Sense
0x804	PWM0FLTSTAT0	PWM0 Fault Status 0
0x808	PWM0FLTSTAT1	PWM0 Fault Status 1
0x880	PWM1FLTSEN	PWM1 Fault Pin Logic Sense
0x884	PWM1FLTSTAT0	PWM1 Fault Status 0
0x888	PWM1FLTSTAT1	PWM1 Fault Status 1
0x900	PWM2FLTSEN	PWM2 Fault Pin Logic Sense
0x904	PWM2FLTSTAT0	PWM2 Fault Status 0
0x908	PWM2FLTSTAT1	PWM2 Fault Status 1
0x980	PWM3FLTSEN	PWM3 Fault Pin Logic Sense
0x984	PWM3FLTSTAT0	PWM3 Fault Status 0
0x988	PWM3FLTSTAT1	PWM3 Fault Status 1
0xFC0	PWMPP	PWM Peripheral Properties
0xFC8	PWMCC	PWM Clock Configuration

**表 6-26. QEI Registers**

OFFSET	ACRONYM	REGISTER NAME
0x0	QEICTL	QEI Control
0x4	QEISTAT	QEI Status
0x8	QEIPPOS	QEI Position
0xC	QEIMAXPOS	QEI Maximum Position
0x10	QEILOAD	QEI Timer Load
0x14	QEITIME	QEI Timer
0x18	QEICOUNT	QEI Velocity Counter
0x1C	QEISPEED	QEI Velocity
0x20	QEIINTEN	QEI Interrupt Enable
0x24	QEIRIS	QEI Raw Interrupt Status
0x28	QEISC	QEI Interrupt Status and Clear

**表 6-27. QSSI Registers**

OFFSET	ACRONYM	REGISTER NAME
0x0	SSICR0	QSSI Control 0
0x4	SSICR1	QSSI Control 1
0x8	SSIDR	QSSI Data
0xC	SSISR	QSSI Status
0x10	SSICPSR	QSSI Clock Prescale
0x14	SSIIM	QSSI Interrupt Mask
0x18	SSIRIS	QSSI Raw Interrupt Status
0x1C	SSIMIS	QSSI Masked Interrupt Status
0x20	SSIICR	QSSI Interrupt Clear
0x24	SSIDMACTL	QSSI DMA Control
0xFC0	SSIPP	QSSI Peripheral Properties
0xFC8	SSICC	QSSI Clock Configuration
0xFD0	SSIPeriphID4	QSSI Peripheral Identification 4

表 6-27. QSSI Registers (continued)

OFFSET	ACRONYM	REGISTER NAME
0xFD4	SSIPeriphID5	QSSI Peripheral Identification 5
0xFD8	SSIPeriphID6	QSSI Peripheral Identification 6
0xFDC	SSIPeriphID7	QSSI Peripheral Identification 7
0xFE0	SSIPeriphID0	QSSI Peripheral Identification 0
0xFE4	SSIPeriphID1	QSSI Peripheral Identification 1
0xFE8	SSIPeriphID2	QSSI Peripheral Identification 2
0xFEC	SSIPeriphID3	QSSI Peripheral Identification 3
0xFF0	SSIPCellID0	QSSI PrimeCell Identification 0
0xFF4	SSIPCellID1	QSSI PrimeCell Identification 1
0xFF8	SSIPCellID2	QSSI PrimeCell Identification 2
0xFFC	SSIPCellID3	QSSI PrimeCell Identification 3

表 6-28. SHA/MD5 Registers

OFFSET	ACRONYM	REGISTER NAME
0x000	SHA_ODIGEST_A	SHA Outer Digest A
0x004	SHA_ODIGEST_B	SHA Outer Digest B
0x008	SHA_ODIGEST_C	SHA Outer Digest C
0x00C	SHA_ODIGEST_D	SHA Outer Digest D
0x010	SHA_ODIGEST_E	SHA Outer Digest E
0x014	SHA_ODIGEST_F	SHA Outer Digest F
0x018	SHA_ODIGEST_G	SHA Outer Digest G
0x01C	SHA_ODIGEST_H	SHA Outer Digest H
0x020	SHA_IDIGEST_A	SHA Inner Digest A
0x024	SHA_IDIGEST_B	SHA Inner Digest B
0x028	SHA_IDIGEST_C	SHA Inner Digest C
0x02C	SHA_IDIGEST_D	SHA Inner Digest D
0x030	SHA_IDIGEST_E	SHA Inner Digest E
0x034	SHA_IDIGEST_F	SHA Inner Digest F
0x038	SHA_IDIGEST_G	SHA Inner Digest G
0x03C	SHA_IDIGEST_H	SHA Inner Digest H
0x40	SHA_DIGEST_COUNT	SHA Digest Count
0x44	SHA_MODE	SHA Mode
0x48	SHA_LENGTH	SHA Length
0x080	SHA_DATA_0_IN	SHA Data 0 Input
0x084	SHA_DATA_1_IN	SHA Data 1 Input
0x088	SHA_DATA_2_IN	SHA Data 2 Input
0x08C	SHA_DATA_3_IN	SHA Data 3 Input
0x090	SHA_DATA_4_IN	SHA Data 4 Input
0x094	SHA_DATA_5_IN	SHA Data 5 Input
0x098	SHA_DATA_6_IN	SHA Data 6 Input
0x09C	SHA_DATA_7_IN	SHA Data 7 Input
0x0A0	SHA_DATA_8_IN	SHA Data 8 Input
0x0A4	SHA_DATA_9_IN	SHA Data 9 Input
0x0A8	SHA_DATA_10_IN	SHA Data 10 Input
0x0AC	SHA_DATA_11_IN	SHA Data 11 Input
0x0B0	SHA_DATA_12_IN	SHA Data 12 Input
0x0B4	SHA_DATA_13_IN	SHA Data 13 Input

**表 6-28. SHA/MD5 Registers (continued)**

OFFSET	ACRONYM	REGISTER NAME
0x0B8	SHA_DATA_14_IN	SHA Data 14 Input
0x0BC	SHA_DATA_15_IN	SHA Data 15 Input
0x100	SHA_REVISION	SHA Revision
0x110	SHA_SYSCONFIG	SHA System Configuration
0x114	SHA_SYSSTATUS	SHA System Status
0x118	SHA_IRQSTATUS	SHA Interrupt Status
0x11C	SHA_IRQENABLE	SHA Interrupt Enable

**表 6-29. SHA/MD5  $\mu$ DMA Registers**

OFFSET	ACRONYM	REGISTER NAME
0x10	SHA_DMAIM	SHA DMA Interrupt Mask
0x14	SHA_DMARIS	SHA DMA Raw Interrupt Status
0x18	SHA_DMAMIS	SHA DMA Masked Interrupt Status
0x1C	SHA_DMAIC	SHA DMA Interrupt Clear

**表 6-30. System Control Memory Registers**

OFFSET	ACRONYM	REGISTER NAME
0xD4	RVP	Reset Vector Pointer
0x1D0	BOOTCFG	Boot Configuration
0x1E0 to 0x1EC	USER_REG_0 to USER_REG_3	User Register 0 to User Register 3
0x200 to 0x23C	FMPRE_0 to FMPRE_15	Flash Memory Protection Read Enable 0 to Flash Memory Protection Read Enable 15
0x400 to 0x43C	FMPPE_0 to FMPPE_15	Flash Memory Protection Program Enable 0 to Flash Memory Protection Program Enable 15

**表 6-31. System Exception Registers**

OFFSET	ACRONYM	REGISTER NAME
0x0	SYSEXCRIS	System Exception Raw Interrupt Status
0x4	SYSEXCIM	System Exception Interrupt Mask
0x8	SYSEXCMIIS	System Exception Masked Interrupt Status
0xC	SYSEXCIC	System Exception Interrupt Clear

**表 6-32. UART Registers**

OFFSET	ACRONYM	REGISTER NAME
0x0	UARTDR	UART Data
0x4	UARTSR/UARTECR	UART Receive Status/Error Clear
0x18	UARTFR	UART Flag
0x20	UARTILPR	UART IrDA Low-Power Register
0x24	UARTIBRD	UART Integer Baud-Rate Divisor
0x28	UARTFBRD	UART Fractional Baud-Rate Divisor
0x2C	UARTLCRH	UART Line Control
0x30	UARTCTL	UART Control
0x34	UARTIFLS	UART Interrupt FIFO Level Select
0x38	UARTIM	UART Interrupt Mask
0x3C	UARTTRIS	UART Raw Interrupt Status
0x40	UARTMIS	UART Masked Interrupt Status
0x44	UARTICR	UART Interrupt Clear

表 6-32. UART Registers (continued)

OFFSET	ACRONYM	REGISTER NAME
0x48	UARTDMACTL	UART DMA Control
0xA4	UART9BITADDR	UART 9-Bit Self Address
0xA8	UART9BITAMASK	UART 9-Bit Self Address Mask
0xFC0	UARTPP	UART Peripheral Properties
0xFC8	UARTCC	UART Clock Configuration
0xFD0	UARTPeriphID4	UART Peripheral Identification 4
0xFD4	UARTPeriphID5	UART Peripheral Identification 5
0xFD8	UARTPeriphID6	UART Peripheral Identification 6
0xFDC	UARTPeriphID7	UART Peripheral Identification 7
0xFE0	UARTPeriphID0	UART Peripheral Identification 0
0xFE4	UARTPeriphID1	UART Peripheral Identification 1
0xFE8	UARTPeriphID2	UART Peripheral Identification 2
0xFEC	UARTPeriphID3	UART Peripheral Identification 3
0xFF0	UARTPCellID0	UART PrimeCell Identification 0
0xFF4	UARTPCellID1	UART PrimeCell Identification 1
0xFF8	UARTPCellID2	UART PrimeCell Identification 2
0xFFC	UARTPCellID3	UART PrimeCell Identification 3

表 6-33. USB Registers

OFFSET	ACRONYM	REGISTER NAME
0x0	USBFADDR	USB Device Functional Address
0x1	USBPOWER	USB Power
0x2	USBTXIS	USB Transmit Interrupt Status
0x4	USBRXIS	USB Receive Interrupt Status
0x6	USBTXIE	USB Transmit Interrupt Enable
0x8	USBRXIE	USB Receive Interrupt Enable
0xA	USBIS	USB General Interrupt Status
0xB	USBIE	USB Interrupt Enable
0xC	USBFRAME	USB Frame Value
0xE	USBEPIDX	USB Endpoint Index
0xF	USBTEST	USB Test Mode
0x20	USBFIFO0	USB FIFO Endpoint 0
0x24	USBFIFO1	USB FIFO Endpoint 1
0x28	USBFIFO2	USB FIFO Endpoint 2
0x2C	USBFIFO3	USB FIFO Endpoint 3
0x30	USBFIFO4	USB FIFO Endpoint 4
0x34	USBFIFO5	USB FIFO Endpoint 5
0x38	USBFIFO6	USB FIFO Endpoint 6
0x3C	USBFIFO7	USB FIFO Endpoint 7
0x60	USBDEVCTL	USB Device Control
0x61	USBCCONF	USB Common Configuration
0x62	USBTXFIFOSZ	USB Transmit Dynamic FIFO Sizing
0x63	USBRXFIFOSZ	USB Receive Dynamic FIFO Sizing
0x64	USBTXFIFOADD	USB Transmit FIFO Start Address
0x66	USBRXFIFOADD	USB Receive FIFO Start Address
0x70	ULPIVBUSCTL	USB ULPI VBUS Control
0x74	ULPIREGDATA	USB ULPI Register Data



**表 6-33. USB Registers (continued)**

OFFSET	ACRONYM	REGISTER NAME
0x75	ULPIREGADDR	USB ULPI Register Address
0x76	ULPIREGCTL	USB ULPI Register Control
0x78	USBEPINFO	USB Endpoint Information
0x79	USBRAMINFO	USB RAM Information
0x7A	USBCONTIM	USB Connect Timing
0x7B	USBVPLEN	USB OTG VBUS Pulse Timing
0x7C	USBHSEOF	USB High-Speed Last Transaction to End of Frame Timing
0x7D	USBFSEOF	USB Full-Speed Last Transaction to End of Frame Timing
0x7E	USBLSEOF	USB Low-Speed Last Transaction to End of Frame Timing
0x80	USBTXFUNCADDR0	USB Transmit Functional Address Endpoint 0
0x82	USBTXHUBADDR0	USB Transmit Hub Address Endpoint 0
0x83	USBTXHUBPORT0	USB Transmit Hub Port Endpoint 0
0x88	USBTXFUNCADDR1	USB Transmit Functional Address Endpoint 1
0x8A	USBTXHUBADDR1	USB Transmit Hub Address Endpoint 1
0x8B	USBTXHUBPORT1	USB Transmit Hub Port Endpoint 1
0x8C	USBRXFUNCADDR1	USB Receive Functional Address Endpoint 1
0x8E	USBRXHUBADDR1	USB Receive Hub Address Endpoint 1
0x8F	USBRXHUBPORT1	USB Receive Hub Port Endpoint 1
0x90	USBTXFUNCADDR2	USB Transmit Functional Address Endpoint 2
0x92	USBTXHUBADDR2	USB Transmit Hub Address Endpoint 2
0x93	USBTXHUBPORT2	USB Transmit Hub Port Endpoint 2
0x94	USBRXFUNCADDR2	USB Receive Functional Address Endpoint 2
0x96	USBRXHUBADDR2	USB Receive Hub Address Endpoint 2
0x97	USBRXHUBPORT2	USB Receive Hub Port Endpoint 2
0x98	USBTXFUNCADDR3	USB Transmit Functional Address Endpoint 3
0x9A	USBTXHUBADDR3	USB Transmit Hub Address Endpoint 3
0x9B	USBTXHUBPORT3	USB Transmit Hub Port Endpoint 3
0x9C	USBRXFUNCADDR3	USB Receive Functional Address Endpoint 3
0x9E	USBRXHUBADDR3	USB Receive Hub Address Endpoint 3
0x9F	USBRXHUBPORT3	USB Receive Hub Port Endpoint 3
0xA0	USBTXFUNCADDR4	USB Transmit Functional Address Endpoint 4
0xA2	USBTXHUBADDR4	USB Transmit Hub Address Endpoint 4
0xA3	USBTXHUBPORT4	USB Transmit Hub Port Endpoint 4
0xA4	USBRXFUNCADDR4	USB Receive Functional Address Endpoint 4
0xA6	USBRXHUBADDR4	USB Receive Hub Address Endpoint 4
0xA7	USBRXHUBPORT4	USB Receive Hub Port Endpoint 4
0xA8	USBTXFUNCADDR5	USB Transmit Functional Address Endpoint 5
0xAA	USBTXHUBADDR5	USB Transmit Hub Address Endpoint 5
0xAB	USBTXHUBPORT5	USB Transmit Hub Port Endpoint 5
0xAC	USBRXFUNCADDR5	USB Receive Functional Address Endpoint 5
0xAE	USBRXHUBADDR5	USB Receive Hub Address Endpoint 5
0xAF	USBRXHUBPORT5	USB Receive Hub Port Endpoint 5
0xB0	USBTXFUNCADDR6	USB Transmit Functional Address Endpoint 6
0xB2	USBTXHUBADDR6	USB Transmit Hub Address Endpoint 6
0xB3	USBTXHUBPORT6	USB Transmit Hub Port Endpoint 6
0xB4	USBRXFUNCADDR6	USB Receive Functional Address Endpoint 6
0xB6	USBRXHUBADDR6	USB Receive Hub Address Endpoint 6

表 6-33. USB Registers (continued)

OFFSET	ACRONYM	REGISTER NAME
0xB7	USBRXHUBPORT6	USB Receive Hub Port Endpoint 6
0xB8	USBTXFUNCADDR7	USB Transmit Functional Address Endpoint 7
0xBA	USBTXHUBADDR7	USB Transmit Hub Address Endpoint 7
0xBB	USBTXHUBPORT7	USB Transmit Hub Port Endpoint 7
0xBC	USBRXFUNCADDR7	USB Receive Functional Address Endpoint 7
0xBE	USBRXHUBADDR7	USB Receive Hub Address Endpoint 7
0xBF	USBRXHUBPORT7	USB Receive Hub Port Endpoint 7
0x102	USBCSRL0	USB Control and Status Endpoint 0 Low
0x103	USBCSRH0	USB Control and Status Endpoint 0 High
0x108	USBCOUNT0	USB Receive Byte Count Endpoint 0
0x10A	USBTTYPE0	USB Type Endpoint 0
0x10B	USBNAKLMT	USB NAK Limit
0x110	USBTXMAXP1	USB Maximum Transmit Data Endpoint 1
0x112	USBTXCSRL1	USB Transmit Control and Status Endpoint 1 Low
0x113	USBTXCSRH1	USB Transmit Control and Status Endpoint 1 High
0x114	USBRXMAXP1	USB Maximum Receive Data Endpoint 1
0x116	USBRXCSRL1	USB Receive Control and Status Endpoint 1 Low
0x117	USBRXCSRH1	USB Receive Control and Status Endpoint 1 High
0x118	USBRXCOUNT1	USB Receive Byte Count Endpoint 1
0x11A	USBTXTYPE1	USB Host Transmit Configure Type Endpoint 1
0x11B	USBTXINTERVAL1	USB Host Transmit Interval Endpoint 1
0x11C	USBRXTYPE1	USB Host Configure Receive Type Endpoint 1
0x11D	USBRXINTERVAL1	USB Host Receive Polling Interval Endpoint 1
0x120	USBTXMAXP2	USB Maximum Transmit Data Endpoint 2
0x122	USBTXCSRL2	USB Transmit Control and Status Endpoint 2 Low
0x123	USBTXCSRH2	USB Transmit Control and Status Endpoint 2 High
0x124	USBRXMAXP2	USB Maximum Receive Data Endpoint 2
0x126	USBRXCSRL2	USB Receive Control and Status Endpoint 2 Low
0x127	USBRXCSRH2	USB Receive Control and Status Endpoint 2 High
0x128	USBRXCOUNT2	USB Receive Byte Count Endpoint 2
0x12A	USBTXTYPE2	USB Host Transmit Configure Type Endpoint 2
0x12B	USBTXINTERVAL2	USB Host Transmit Interval Endpoint 2
0x12C	USBRXTYPE2	USB Host Configure Receive Type Endpoint 2
0x12D	USBRXINTERVAL2	USB Host Receive Polling Interval Endpoint 2
0x130	USBTXMAXP3	USB Maximum Transmit Data Endpoint 3
0x132	USBTXCSRL3	USB Transmit Control and Status Endpoint 3 Low
0x133	USBTXCSRH3	USB Transmit Control and Status Endpoint 3 High
0x134	USBRXMAXP3	USB Maximum Receive Data Endpoint 3
0x136	USBRXCSRL3	USB Receive Control and Status Endpoint 3 Low
0x137	USBRXCSRH3	USB Receive Control and Status Endpoint 3 High
0x138	USBRXCOUNT3	USB Receive Byte Count Endpoint 3
0x13A	USBTXTYPE3	USB Host Transmit Configure Type Endpoint 3
0x13B	USBTXINTERVAL3	USB Host Transmit Interval Endpoint 3
0x13C	USBRXTYPE3	USB Host Configure Receive Type Endpoint 3
0x13D	USBRXINTERVAL3	USB Host Receive Polling Interval Endpoint 3
0x140	USBTXMAXP4	USB Maximum Transmit Data Endpoint 4
0x142	USBTXCSRL4	USB Transmit Control and Status Endpoint 4 Low

**表 6-33. USB Registers (continued)**

OFFSET	ACRONYM	REGISTER NAME
0x143	USBTXCSRH4	USB Transmit Control and Status Endpoint 4 High
0x144	USBRXMAXP4	USB Maximum Receive Data Endpoint 4
0x146	USBRXCURL4	USB Receive Control and Status Endpoint 4 Low
0x147	USBRXCSRH4	USB Receive Control and Status Endpoint 4 High
0x148	USBRXCOUNT4	USB Receive Byte Count Endpoint 4
0x14A	USBTXTYPE4	USB Host Transmit Configure Type Endpoint 4
0x14B	USBTXINTERVAL4	USB Host Transmit Interval Endpoint 4
0x14C	USBRXTYPE4	USB Host Configure Receive Type Endpoint 4
0x14D	USBRXINTERVAL4	USB Host Receive Polling Interval Endpoint 4
0x150	USBTXMAXP5	USB Maximum Transmit Data Endpoint 5
0x152	USBTXCURL5	USB Transmit Control and Status Endpoint 5 Low
0x153	USBTXCSRH5	USB Transmit Control and Status Endpoint 5 High
0x154	USBRXMAXP5	USB Maximum Receive Data Endpoint 5
0x156	USBRXCURL5	USB Receive Control and Status Endpoint 5 Low
0x157	USBRXCSRH5	USB Receive Control and Status Endpoint 5 High
0x158	USBRXCOUNT5	USB Receive Byte Count Endpoint 5
0x15A	USBTXTYPE5	USB Host Transmit Configure Type Endpoint 5
0x15B	USBTXINTERVAL5	USB Host Transmit Interval Endpoint 5
0x15C	USBRXTYPE5	USB Host Configure Receive Type Endpoint 5
0x15D	USBRXINTERVAL5	USB Host Receive Polling Interval Endpoint 5
0x160	USBTXMAXP6	USB Maximum Transmit Data Endpoint 6
0x162	USBTXCURL6	USB Transmit Control and Status Endpoint 6 Low
0x163	USBTXCSRH6	USB Transmit Control and Status Endpoint 6 High
0x164	USBRXMAXP6	USB Maximum Receive Data Endpoint 6
0x166	USBRXCURL6	USB Receive Control and Status Endpoint 6 Low
0x167	USBRXCSRH6	USB Receive Control and Status Endpoint 6 High
0x168	USBRXCOUNT6	USB Receive Byte Count Endpoint 6
0x16A	USBTXTYPE6	USB Host Transmit Configure Type Endpoint 6
0x16B	USBTXINTERVAL6	USB Host Transmit Interval Endpoint 6
0x16C	USBRXTYPE6	USB Host Configure Receive Type Endpoint 6
0x16D	USBRXINTERVAL6	USB Host Receive Polling Interval Endpoint 6
0x170	USBTXMAXP7	USB Maximum Transmit Data Endpoint 7
0x172	USBTXCURL7	USB Transmit Control and Status Endpoint 7 Low
0x173	USBTXCSRH7	USB Transmit Control and Status Endpoint 7 High
0x174	USBRXMAXP7	USB Maximum Receive Data Endpoint 7
0x176	USBRXCURL7	USB Receive Control and Status Endpoint 7 Low
0x177	USBRXCSRH7	USB Receive Control and Status Endpoint 7 High
0x178	USBRXCOUNT7	USB Receive Byte Count Endpoint 7
0x17A	USBTXTYPE7	USB Host Transmit Configure Type Endpoint 7
0x17B	USBTXINTERVAL7	USB Host Transmit Interval Endpoint 7
0x17C	USBRXTYPE7	USB Host Configure Receive Type Endpoint 7
0x17D	USBRXINTERVAL7	USB Host Receive Polling Interval Endpoint 7
0x200	USBDMAINTR	USB DMA Interrupt
0x204	USBDMACTL0	USB DMA Control 0
0x208	USBDMAADDR0	USB DMA Address 0
0x20C	USBDMACOUNT0	USB DMA Count 0
0x214	USBDMACTL1	USB DMA Control 1

表 6-33. USB Registers (continued)

OFFSET	ACRONYM	REGISTER NAME
0x218	USBDMAADDR1	USB DMA Address 1
0x21C	USBDMACOUNT1	USB DMA Count 1
0x224	USBDMACTL2	USB DMA Control 2
0x228	USBDMAADDR2	USB DMA Address 2
0x22C	USBDMACOUNT2	USB DMA Count 2
0x234	USBDMACTL3	USB DMA Control 3
0x238	USBDMAADDR3	USB DMA Address 3
0x23C	USBDMACOUNT3	USB DMA Count 3
0x244	USBDMACTL4	USB DMA Control 4
0x248	USBDMAADDR4	USB DMA Address 4
0x24C	USBDMACOUNT4	USB DMA Count 4
0x254	USBDMACTL5	USB DMA Control 5
0x258	USBDMAADDR5	USB DMA Address 5
0x25C	USBDMACOUNT5	USB DMA Count 5
0x264	USBDMACTL6	USB DMA Control 6
0x268	USBDMAADDR6	USB DMA Address 6
0x26C	USBDMACOUNT6	USB DMA Count 6
0x274	USBDMACTL7	USB DMA Control 7
0x278	USBDMAADDR7	USB DMA Address 7
0x27C	USBDMACOUNT7	USB DMA Count 7
0x304	USBRQPKTCOUNT1	USB Request Packet Count in Block Transfer Endpoint 1
0x308	USBRQPKTCOUNT2	USB Request Packet Count in Block Transfer Endpoint 2
0x30C	USBRQPKTCOUNT3	USB Request Packet Count in Block Transfer Endpoint 3
0x310	USBRQPKTCOUNT4	USB Request Packet Count in Block Transfer Endpoint 4
0x314	USBRQPKTCOUNT5	USB Request Packet Count in Block Transfer Endpoint 5
0x318	USBRQPKTCOUNT6	USB Request Packet Count in Block Transfer Endpoint 6
0x31C	USBRQPKTCOUNT7	USB Request Packet Count in Block Transfer Endpoint 7
0x340	USBRXDPKTBUFDIS	USB Receive Double Packet Buffer Disable
0x342	USBTXDPKTBUFDIS	USB Transmit Double Packet Buffer Disable
0x344	USBCTO	USB Chirp Time-out
0x346	USBHHSRTN	USB High Speed to UTM Operating Delay
0x348	USBHSBT	USB High Speed Time-out Adder
0x360	USBLPMATTR	USB LPM Attributes
0x362	USBLPMCNTL	USB LPM Control
0x363	USBLPMIM	USB LPM Interrupt Mask
0x364	USBLPMRIS	USB LPM Raw Interrupt Status
0x365	USBLPMFADDR	USB LPM Function Address
0x400	USBEPCC	USB External Power Control
0x404	USBEPCCRIS	USB External Power Control Raw Interrupt Status
0x408	USBEPCCIM	USB External Power Control Interrupt Mask
0x40C	USBEPCCISC	USB External Power Control Interrupt Status and Clear
0x410	USBDRRIS	USB Device RESUME Raw Interrupt Status
0x414	USBDRIM	USB Device RESUME Interrupt Mask
0x418	USBDRISC	USB Device RESUME Interrupt Status and Clear
0x41C	USBGPCS	USB General-Purpose Control and Status
0x430	USBVDC	USB VBUS Droop Control
0x434	USBVDCRIS	USB VBUS Droop Control Raw Interrupt Status

**表 6-33. USB Registers (continued)**

OFFSET	ACRONYM	REGISTER NAME
0x438	USBVDCIM	USB VBUS Droop Control Interrupt Mask
0x43C	USBVDCISC	USB VBUS Droop Control Interrupt Status and Clear
0xFC0	USBPP	USB Peripheral Properties
0xFC4	USBPC	USB Peripheral Configuration
0xFC8	USBCC	USB Clock Configuration

**表 6-34. WDT Registers**

OFFSET	ACRONYM	REGISTER NAME
0x0	WDTLOAD	Watchdog Load
0x4	WDTVALUE	Watchdog Value
0x8	WDTCTL	Watchdog Control
0xC	WDTICR	Watchdog Interrupt Clear
0x10	WDTRIS	Watchdog Raw Interrupt Status
0x14	WDTMIS	Watchdog Masked Interrupt Status
0x418	WDTTEST	Watchdog Test
0xC00	WDTLOCK	Watchdog Lock
0xFD0	WDTPeriphID4	Watchdog Peripheral Identification 4
0xFD4	WDTPeriphID5	Watchdog Peripheral Identification 5
0xFD8	WDTPeriphID6	Watchdog Peripheral Identification 6
0xFDC	WDTPeriphID7	Watchdog Peripheral Identification 7
0xFE0	WDTPeriphID0	Watchdog Peripheral Identification 0
0xFE4	WDTPeriphID1	Watchdog Peripheral Identification 1
0xFE8	WDTPeriphID2	Watchdog Peripheral Identification 2
0xFEC	WDTPeriphID3	Watchdog Peripheral Identification 3
0xFF0	WDTPrimeCellID0	Watchdog PrimeCell Identification 0
0xFF4	WDTPrimeCellID1	Watchdog PrimeCell Identification 1
0xFF8	WDTPrimeCellID2	Watchdog PrimeCell Identification 2
0xFFC	WDTPrimeCellID3	Watchdog PrimeCell Identification 3

## 6.6 Identification

### Device Identification

Read-only registers in the system control module provide information about the MCU, such as version, part number, pin count, operating temperature range, and available peripherals on the device. The Device Identification 0 (DID0) and Device Identification 1 (DID1) registers provide details about the version, package, and temperature range of the device. The peripheral present registers starting at system control offset 0x300, such as the Watchdog Timer Peripheral Present (PPWD) register, provide information on how many of each type of module are included on the device. Finally, information about the capabilities of the on-chip peripherals are provided at offset 0xFC0 in the register space of each peripheral in the peripheral properties registers, such as the GPTM Peripheral Properties (GPTMPP). In addition, four unique identifier registers, Unique Identifier n (UNIQUEIDn), provide a 128-bit unique identifier that cannot be modified for each device.

### JTAG Identification

图 6-3 shows the format for the 32-bit IDCODE Data Register defined by the IEEE Standard 1149.1. The major uses of the JTAG port are for manufacturer testing of component assembly and program development and debug. To facilitate the use of auto-configuration debug tools, the IDCODE instruction outputs a value of 0x4BA0.0477. This value lets the debuggers automatically configure themselves to work correctly with the Cortex-M4F during debug.



图 6-3. IDCODE Register Format

## ROM Version

The internal ROM is at address 0x0100.0000 of the device memory map.

## 6.7 Boot Modes

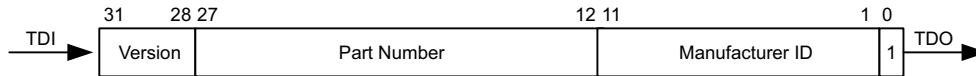
After POR and device initialization occurs, the hardware loads the stack pointer from either flash or ROM, based on the presence of an application in flash and the state of the EN bit in the BOOTCFG register.

If the flash address 0x0000.0004 contains an erased word (value 0xFFFF.FFFF) or the EN bit of the BOOTCFG register is clear, the stack pointer and reset vector pointer are loaded from ROM at address 0x0100.0000 and 0x0100.0004, respectively. The bootloader executes and configures the available boot slave interfaces and waits for a programmer, host PC, or boot server to load its software. The bootloader uses a simple packet interface to provide synchronous communication with the device for I<sup>2</sup>C, SSI, and UART. The speed of the bootloader is determined by the frequency of the internal oscillator (PIOSC) or external crystal (if connected).

The ROM invokes the USB and Ethernet bootloader only when an external crystal is detected. Also, the Ethernet bootloader works only when a 25-MHz crystal is detected.

The following serial interfaces can be used:

- UART0
- SSI0
- I2C0
- USB
- Ethernet MAC and Integrated PHY

If the check of the flash at address 0x0000.0004 contains a valid reset vector value and the EN bit in the BOOTCFG register is set, the stack pointer and reset vector values are fetched from the beginning of flash. This application stack pointer and reset vector are loaded and the processor executes the application directly. Otherwise, the stack pointer and reset vector values are fetched from the beginning of ROM.

## 7 Applications, Implementation, and Layout

---

### 注

Information in the following Applications section is not part of the TI component specification, and TI does not warrant its accuracy or completeness. TI's customers are responsible for determining suitability of components for their purposes. Customers should validate and test their design implementation to confirm system functionality.

---

### 7.1 System Design Guidelines

The SimpleLink MSP432E4 microcontrollers are highly-integrated system-on-chip (SoC) devices with extensive interface and processing capabilities. Consequently, there are many factors to consider when creating a schematic and designing a circuit board. By following the recommendations in this design guide, your confidence will increase that the board will work successfully upon initial power up.

[System Design Guidelines for MSP432E4 SimpleLink™ Microcontrollers](#)



## 8 器件和文档支持

### 8.1 入门和后续步骤

TI 提供大量的开发工具。下面是用于评估器件性能、生成代码和开发解决方案的工具和软件。

### 8.2 器件命名规则

为了指出产品开发周期所处的阶段，TI 为所有微处理器 (MPU) 和支持工具的产品型号分配了前缀。每个器件都具有以下三个前缀中的其中一个：XMS、PMS 或 MSP。这些前缀代表了产品开发的发展阶段，即从工程原型直到完全合格的生产器件和工具。

器件开发进化流程：

**XMS** 试验器件不一定代表最终器件的电气规范标准，并且可能不使用生产组装流程。

**PMS** 原型器件不一定是最终器件模型，并且不一定符合最终电气标准规范。

**MSP** 完全合格的器件模型的生产版本。

试验器件和工具在供货时附带如下免责声明：

“开发中的产品用于内部评估用途。”

生产器件和开发支持工具已进行完全特性描述，并且器件的质量和可靠性已经完全论证。TI 的标准保修证书适用。

预测显示原型器件的故障率大于标准生产器件。由于这些器件的预计最终使用故障率仍未定义，德州仪器 (TI) 建议不要将它们用于任何生产系统。只有合格的产品器件将被使用。

TI 器件的命名规则也包括一个带有器件系列名称的后缀。这个后缀表示封装类型（例如，ZAD）和温度范围（例如，“空白”是默认的商业级温度范围）。图 8-1 显示了完整器件名称的解读图例。

有关器件的订购部件号，请参阅本文档的封装选项附录、[ti.com.cn](http://ti.com.cn) 或者与您的 TI 销售代表联系。

有关裸片器件命名规则标记的其他说明，请参阅具体器件的《器件勘误表》。

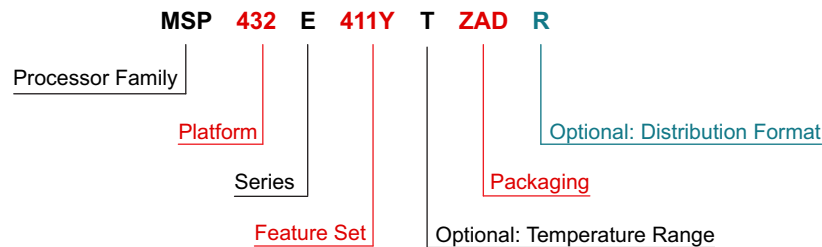

<b>Processor Family</b>	MSP = Mixed-Signal Processor XMS = Experimental Silicon			
<b>Platform</b>	432 = TI's 32-Bit Low-Power Microcontroller Platform			
<b>Series</b>	E = Ethernet and Wired Connectivity Series			
<b>Feature Set</b>	<b>First Digit</b> 4 = Flash-based devices up to 120 MHz	<b>Second Digit</b> 1 = LCD 0 = No LCD	<b>Third Digit</b> 1 = ADC 0 = No ADC	<b>Fourth Digit</b> Y = 1MB Flash
<b>Optional: Temperature Range</b>	T = -40°C to 105°C			
<b>Packaging</b>	<a href="http://www.ti.com/packaging">http://www.ti.com/packaging</a>			
<b>Optional: Distribution Format</b>	T = Small reel R = Large reel No markings = Tube or tray			

图 8-1. 器件命名规则



## 8.3 工具和软件

### 设计套件与评估模块

**MSP432E401Y SimpleLink 微控制器 LaunchPad 开发套件** SimpleLink 以太网 MSP432E401Y 微控制器 LaunchPad 开发套件是一款适用于基于 SimpleLink Arm Cortex-M4F 以太网微控制器的低成本评估平台。以太网 LaunchPad 开发套件设计的重点突出了 MSP432E401Y 微控制器及其片上 10/100 以太网 MAC 和 PHY、USB 2.0、休眠模块、运动控制脉宽调制以及大量同步串行连接。

### 软件

**SimpleLink MSP432E4 软件开发套件 (SDK)** MSP432E4 SDK 是一套综合性的软件包，可帮助工程师在德州仪器 (TI) MSP432E4 MCU 上快速开发功能强大的应用。MSP432E4 SDK 由多个兼容软件组件构成，其中包括 RTOS、驱动程序和中间件以及一些如何一起使用这些组件的示例。此外，还提供了各种示例来展示如何使用各功能区和各个受支持的器件，同时这些示例还可用作您自己的项目的起点。

### 开发工具

**适用于 MSP 微控制器的 Code Composer Studio™ 集成开发环境** Code Composer Studio 是一种集成开发环境 (IDE)，支持所有 MSP430 和 SimpleLink MSP432 微控制器器件。Code Composer Studio 包含一整套开发和调试嵌入式应用的嵌入式软件实用程序。它包含了优化的 C/C++ 编译器、源代码编辑器、项目构建环境、调试器、描述器以及其他多种功能。借助集成式 TI 资源浏览器，您可以访问适用于您的器件和开发板的更多示例、库、可执行代码和文档。有关更多信息，请参阅《适用于 SimpleLink™ MSP432™ 微控制器的 Code Composer Studio™ IDE 用户指南》。

**IAR 嵌入式工作平台 Kickstart** 适用于 MSP 的 IAR 嵌入式工作平台 Kickstart 是一套完整的调试器和 C/C++ 编译器工具链，可用于构建和调试基于 MSP430 和 SimpleLink MSP432 微控制器的嵌入式应用。MSP430 器件和 MSP432 器件的 C/C++ 编译器代码尺寸限制分别为 8KB 和 32KB。有关更多信息，请参阅《适用于 SimpleLink™ MSP432™ 微控制器的 IAR Embedded Workbench® for ARM® 用户指南》。

**Arm® Keil® MDK – 免费 32KB IDE** Arm Keil MDK 是一套完整的调试器和 C/C++ 编译器工具链，可用于构建和调试嵌入式应用。Keil MDK 支持低功耗和高性能 SimpleLink MSP432 MCU 系列，并且它还包括一个全集成调试器，适用于源代码级调试和反汇编级调试，支持复杂代码和数据断点。对于此 IDE，SimpleLink MSP432 软件开发套件 (SDK) 中仅支持非 RTOS 示例。有关更多信息，请参阅《适用于 SimpleLink™ MSP432™ 微控制器的 Arm® Keil® MDK 用户指南》。

**MSP432E CMSIS 器件系列软件包** TI 为 MSP432E 器件提供了符合 CMSIS 标准的器件系列软件包。该软件包将 MSP432E 器件支持添加到 IAR EWArm 8.x、Keil MDK 5.x 和 Atollic True Studio 7.x。在 IAR EWArm 中，该软件包是可选的，因为 IDE 本身便支持这些器件。

**适用于 MSP432 的调试器** 根据设计，SimpleLink MSP432E MCU 可与 TI 及第三方供应商的各种调试器结合使用。MSP-FET 不支持 MSP432E 器件系列。

## 8.4 文档支持

如需接收文档更新通知，请访问 [ti.com](http://ti.com) 上的器件产品文件夹。单击右上角的通知我进行注册，即可每周接收产品信息更改摘要。有关更改的详细信息，请查看任何已修订文档中包含的修订历史记录。

以下文档描述了 MCU、相关外设和其他技术材料。

### 勘误表

《[MSP432E4 SimpleLink™ 微控制器器件勘误表](#)》介绍与已发布的规格不同的器件行为

### 应用报告

《[SimpleLink™ MSP432E4 微控制器的系统设计指南](#)》 SimpleLink MSP432E4 微控制器是高度集成的片上系统 (SOC) 器件，具有扩展接口和处理功能。因此，在创建原理图和设计电路板时要考虑很多因素。通过采用本设计指南中的建议，您会更有信心，设计的电路板在首次加电时就可以有效工作。

《[在 SimpleLink MSP432E4 微控制器上使用 I<sup>2</sup>C 主机的功能集](#)》 内部集成电路 (I<sup>2</sup>C) 是一个多主从单端总线，通常用于将速度较低的外设 IC 连接到处理器和微控制器。从器件涵盖从非易失性存储器到数据采集器件在内的各类型器件，如模数转换器 (ADC)、传感器等。本应用报告展示了如何在 SimpleLink MSP432E4 微控制器上使用功能丰富的 I<sup>2</sup>C 主机与系统中的多个从器件通信。

《[通过 JTAG 接口使用 SimpleLink MSP432E4 微控制器](#)》 IEEE 标准 1149.1 - 1990、IEEE 标准测试访问端口和边界扫描架构 (JTAG) 是一种用于验证设计和测试组装后的印刷电路板的方法。它是将数据传输到嵌入式系统的非易失性存储器和调试嵌入式软件的主要手段。本应用报告介绍了 JTAG 的物理连接和设计自定义电路板时需要考虑的注意事项。它还说明了如何使用 SimpleLink MSP432E4 LaunchPad 开发套件上的 JTAG 接口，以通过外部调试器调试板载微控制器，或使用板载调试器调试非板载微控制器。

### 用户指南

《[MSP432E4 SimpleLink™ 微控制器技术参考手册](#)》介绍 MSP432E4 系列微控制器，包括围绕 Arm Cortex-M4F 内核设计的片上系统 (SoC) 器件的功能块。

《[MSP432E4 SimpleLink™ 微控制器引导加载程序用户指南](#)》 引导加载程序是一小段代码，可以编程到闪存的开始位置，以使用作应用加载程序。也可以用作在 SimpleLink MSP432E4 基于 Arm Cortex-M4 的微控制器上运行的应用的更新机制。引导加载程序可以搭建为使用 UART、SSI、I<sup>2</sup>C、CAN、以太网或 USB 端口来更新微控制器上的代码。通过源代码修改，或者简单地在编译时决定要包括的例程，可以定制引导加载程序。由于提供了完整源代码，因此引导加载程序可完全自定义

## 8.5 Community Resources

下列链接提供到 TI 社区资源的连接。链接的内容由各个分销商“按照原样”提供。这些内容并不构成 TI 技术规范，并且不一定反映 TI 的观点；请参阅 TI 的《使用条款》。

**TI E2E™ 在线社区** 为了促进工程师之间的合作，我们创建了 TI 工程师对工程师 (E2E) 社区。在 [e2e.ti.com](http://e2e.ti.com) 中，您可以提问、分享知识、拓展思路并与同行工程师一道帮助解决问题。

**TI Embedded Processors Wiki** Established to help developers get started with Embedded Processors from Texas Instruments and to foster innovation and growth of general knowledge about the hardware and software surrounding these devices.

## 8.6 商标

SimpleLink, LaunchPad, MSP432, E2E are trademarks of Texas Instruments.  
 ARM, Cortex, Thumb, Thumb-2, PrimeCell, Arm7 are registered trademarks of Arm Limited.  
 Bluetooth is a registered trademark of Bluetooth SIG.  
 Wi-Fi is a registered trademark of Wi-Fi Alliance.  
 All other trademarks are the property of their respective owners.

## 8.7 静电放电警告



ESD 可能会损坏该集成电路。德州仪器 (TI) 建议通过适当的预防措施处理所有集成电路。如果不遵守正确的处理措施和安装程序，可能会损坏集成电路。

ESD 的损坏小至导致微小的性能降级，大至整个器件故障。精密的集成电路可能更容易受到损坏，这是因为非常细微的参数更改都可能会导致器件与其发布的规格不相符。

## 8.8 出口管制提示

接收方同意：如果美国或其他适用法律限制或禁止将通过非披露义务的披露方获得的任何产品或技术数据（其中包括软件）（见美国、欧盟和其他出口管理条例之定义）、或者其他适用国家条例限制的任何受管制产品或此项技术的任何直接产品出口或再出口至任何目的地，那么在没有事先获得美国商务部和其他相关政府机构授权的情况下，接收方不得在知情的情况下，以直接或间接的方式将其出口。

## 8.9 术语表

**TI 术语表** 这份术语表列出并解释术语、缩写和定义。

## 9 机械、封装和可订购信息

以下页面包含机械、封装和可订购信息。这些信息是指定器件的最新可用数据。数据如有变更，恕不另行通知和修订此文档。如欲获取此数据表的浏览器版本，请参阅左侧的导航。

**PACKAGING INFORMATION**

Orderable Device	Status (1)	Package Type	Package Drawing	Pins	Package Qty	Eco Plan (2)	Lead finish/ Ball material (6)	MSL Peak Temp (3)	Op Temp (°C)	Device Marking (4/5)	Samples
MSP432E411YTZAD	ACTIVE	NFBGA	ZAD	212	184	RoHS & Green	SNAGCU	Level-3-260C-168 HR	-40 to 105	E411YT	<a href="#">Samples</a>
MSP432E411YTZADR	ACTIVE	NFBGA	ZAD	212	1000	RoHS & Green	SNAGCU	Level-3-260C-168 HR	-40 to 105	E411YT	<a href="#">Samples</a>

(1) The marketing status values are defined as follows:

**ACTIVE:** Product device recommended for new designs.

**LIFEBUY:** TI has announced that the device will be discontinued, and a lifetime-buy period is in effect.

**NRND:** Not recommended for new designs. Device is in production to support existing customers, but TI does not recommend using this part in a new design.

**PREVIEW:** Device has been announced but is not in production. Samples may or may not be available.

**OBSOLETE:** TI has discontinued the production of the device.

(2) **RoHS:** TI defines "RoHS" to mean semiconductor products that are compliant with the current EU RoHS requirements for all 10 RoHS substances, including the requirement that RoHS substance do not exceed 0.1% by weight in homogeneous materials. Where designed to be soldered at high temperatures, "RoHS" products are suitable for use in specified lead-free processes. TI may reference these types of products as "Pb-Free".

**RoHS Exempt:** TI defines "RoHS Exempt" to mean products that contain lead but are compliant with EU RoHS pursuant to a specific EU RoHS exemption.

**Green:** TI defines "Green" to mean the content of Chlorine (Cl) and Bromine (Br) based flame retardants meet JS709B low halogen requirements of <=1000ppm threshold. Antimony trioxide based flame retardants must also meet the <=1000ppm threshold requirement.

(3) MSL, Peak Temp. - The Moisture Sensitivity Level rating according to the JEDEC industry standard classifications, and peak solder temperature.

(4) There may be additional marking, which relates to the logo, the lot trace code information, or the environmental category on the device.

(5) Multiple Device Markings will be inside parentheses. Only one Device Marking contained in parentheses and separated by a "~" will appear on a device. If a line is indented then it is a continuation of the previous line and the two combined represent the entire Device Marking for that device.

(6) Lead finish/Ball material - Orderable Devices may have multiple material finish options. Finish options are separated by a vertical ruled line. Lead finish/Ball material values may wrap to two lines if the finish value exceeds the maximum column width.

**Important Information and Disclaimer:**The information provided on this page represents TI's knowledge and belief as of the date that it is provided. TI bases its knowledge and belief on information provided by third parties, and makes no representation or warranty as to the accuracy of such information. Efforts are underway to better integrate information from third parties. TI has taken and continues to take reasonable steps to provide representative and accurate information but may not have conducted destructive testing or chemical analysis on incoming materials and chemicals. TI and TI suppliers consider certain information to be proprietary, and thus CAS numbers and other limited information may not be available for release.

In no event shall TI's liability arising out of such information exceed the total purchase price of the TI part(s) at issue in this document sold by TI to Customer on an annual basis.



## 重要声明和免责声明

TI“按原样”提供技术和可靠性数据（包括数据表）、设计资源（包括参考设计）、应用或其他设计建议、网络工具、安全信息和其他资源，不保证没有瑕疵且不做任何明示或暗示的担保，包括但不限于对适销性、某特定用途方面的适用性或不侵犯任何第三方知识产权的暗示担保。

这些资源可供使用 TI 产品进行设计的熟练开发人员使用。您将自行承担以下全部责任：(1) 针对您的应用选择合适的 TI 产品，(2) 设计、验证并测试您的应用，(3) 确保您的应用满足相应标准以及任何其他功能安全、信息安全、监管或其他要求。

这些资源如有变更，恕不另行通知。TI 授权您仅可将这些资源用于研发本资源所述的 TI 产品的应用。严禁对这些资源进行其他复制或展示。您无权使用任何其他 TI 知识产权或任何第三方知识产权。您应全额赔偿因在这些资源的使用中对 TI 及其代表造成的任何索赔、损害、成本、损失和债务，TI 对此概不负责。

TI 提供的产品受 [TI 的销售条款](#) 或 [ti.com](#) 上其他适用条款/TI 产品随附的其他适用条款的约束。TI 提供这些资源并不会扩展或以其他方式更改 TI 针对 TI 产品发布的适用的担保或担保免责声明。

TI 反对并拒绝您可能提出的任何其他或不同的条款。

邮寄地址：Texas Instruments, Post Office Box 655303, Dallas, Texas 75265

Copyright © 2023，德州仪器 (TI) 公司