

# OPA2836-Q1 超低功耗、轨到轨输出、负电源轨输入、电压反馈运算放大器

## 1 特性

- 适用于汽车电子应用
- 具有符合 AEC-Q100 的下列结果：
  - 器件温度 1 级：-40°C 至 125°C 的环境运行温度范围
  - 器件人体放电模式 (HBM) 分类等级 2
  - 器件组件充电模式 (CDM) 分类等级 C6
- 低功耗：
  - 电源电压：2.5V 至 5.5V
  - 静态电流：1mA (典型值)
  - 掉电模式：0.5 $\mu$ A (典型值)
- 带宽：205MHz
- 转换率：560V/ $\mu$ s
- 上升时间：3ns (2V<sub>STEP</sub>)
- 稳定时间 (0.1%)：22ns (2 V<sub>STEP</sub>)
- 过驱恢复时间：60ns
- 信噪比 (SNR)：在 1kHz (1V<sub>RMS</sub>) 时为 0.00013% (-117.6dBc)
- 总谐波失真 (THD)：在 1kHz (1V<sub>RMS</sub>) 时为 0.00003% (-130dBc)
- HD<sub>2</sub>、HD<sub>3</sub>：1MHz 下分别为 -85dBc、-105dBc (2V<sub>PP</sub>)
- 输入电压噪声：4.6nV/ $\sqrt{\text{Hz}}$  (f = 100kHz)
- 输入偏移电压：65 $\mu$ V (最大值为  $\pm$ 400 $\mu$ V)
- 共模抑制比 (CMRR)：116dB
- 输出驱动电流：50mA
- RRO：轨到轨输出
- 输入电压范围：-0.2V 至 +3.9V (5V 电源)

## 2 应用

- 低功耗信号调节
- 音频模数转换器 (ADC) 输入缓冲器
- 低功耗逐次逼近寄存器 (SAR) 和三角积分 ( $\Delta\Sigma$ ) ADC 驱动器
- 便携式系统
- 低功耗系统
- 高密度系统

## 3 说明

OPA2836-Q1 器件是一款双通道超低功耗、轨到轨输出、负电源轨输入、电压反馈运算放大器，经过设计可由 2.5V 至 5.5V 范围内的单电源或者  $\pm$ 1.25V 至  $\pm$ 2.75V 范围内的双电源供电运行。该放大器每通道仅消耗 1mA 的电流，单位增益带宽为 205MHz，功耗性能比处于业内领先水平。

OPA2836-Q1 器件兼具低功耗特性和出色的高频性能，并且可实现其他同类器件所无法达到的性能/功耗比，因此非常适合注重功耗方面的电池供电类便携式应用。

OPA2836-Q1 在 -40°C 至 +125°C 的扩展级工业温度范围内额定运行。

器件信息<sup>(1)</sup>

| 器件型号       | 封装        | 封装尺寸 (标称值)      |
|------------|-----------|-----------------|
| OPA2836-Q1 | VSSOP (8) | 3.00mm x 3.00mm |

(1) 要了解所有可用封装，请见数据表末尾的可订购产品附录。

谐波失真与频率间的关系

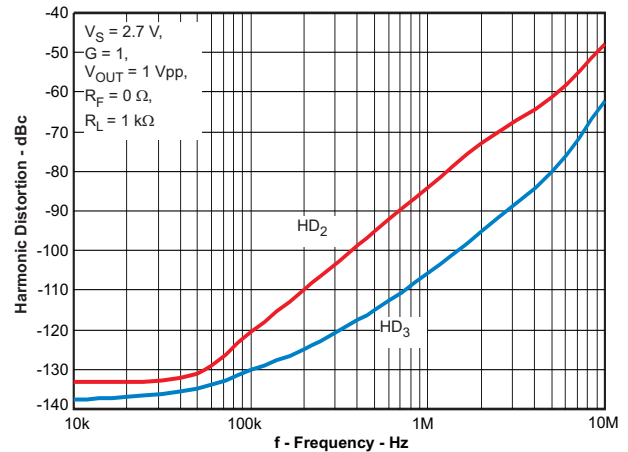

## 目录

|          |  |           |           |   |           |
|----------|--|-----------|-----------|---|-----------|
| <b>1</b> | 特性 .....   | <b>1</b>  | 8.4       | Device Functional Modes.....                | <b>24</b> |
| <b>2</b> | 应用 .....   | <b>1</b>  | <b>9</b>  | <b>Application and Implementation .....</b> | <b>28</b> |
| <b>3</b> | 说明 .....   | <b>1</b>  | 9.1       | Application Information.....                | <b>28</b> |
| <b>4</b> | 修订历史记录 .....   | <b>2</b>  | 9.2       | Typical Applications .....                  | <b>34</b> |
| <b>5</b> | <b>OPA2836-Q1 Related Devices .....</b>                | <b>3</b>  | <b>10</b> | <b>Power Supply Recommendations .....</b>   | <b>37</b> |
| <b>6</b> | <b>Pin Configuration and Functions .....</b>           | <b>3</b>  | <b>11</b> | <b>Layout.....</b>                          | <b>37</b> |
| <b>7</b> | <b>Specifications.....</b>                             | <b>4</b>  | 11.1      | Layout Guidelines .....                     | <b>37</b> |
| 7.1      | Absolute Maximum Ratings .....                         | <b>4</b>  | 11.2      | Layout Example .....                        | <b>38</b> |
| 7.2      | ESD Ratings.....                                       | <b>4</b>  | <b>12</b> | <b>器件和文档支持 .....</b>                        | <b>39</b> |
| 7.3      | Recommended Operating Conditions.....                  | <b>4</b>  | 12.1      | 器件支持 .....                                  | <b>39</b> |
| 7.4      | Thermal Information .....                              | <b>4</b>  | 12.2      | 相关链接 .....                                  | <b>39</b> |
| 7.5      | Electrical Characteristics: $V_S = 2.7\text{ V}$ ..... | <b>5</b>  | 12.3      | 接收文档更新通知 .....                              | <b>39</b> |
| 7.6      | Electrical Characteristics: $V_S = 5\text{ V}$ .....   | <b>7</b>  | 12.4      | 社区资源 .....                                  | <b>39</b> |
| 7.7      | Typical Characteristics .....                          | <b>9</b>  | 12.5      | 商标 .....                                    | <b>39</b> |
| <b>8</b> | <b>Detailed Description .....</b>                      | <b>21</b> | 12.6      | 静电放电警告 .....                                | <b>39</b> |
| 8.1      | Overview .....   | <b>21</b> | 12.7      | Glossary .....                              | <b>39</b> |
| 8.2      | Functional Block Diagrams .....                        | <b>21</b> | <b>13</b> | <b>机械、封装和可订购信息 .....</b>                    | <b>39</b> |
| 8.3      | Feature Description.....                               | <b>21</b> |           |   |           |

## 4 修订历史记录

| 日期          | 修订版本 | 注释      |
|-------------|------|---------|
| 2016 年 12 月 | *    | 最初发布版本。 |

## 5 OPA2836-Q1 Related Devices

| DEVICE                  | BW ( $A_V = 1$ ) (MHz) | SLEW RATE ( $V/\mu s$ ) | $I_Q$ (5 V) (mA) | INPUT NOISE ( $nV/\sqrt{Hz}$ ) | RAIL-TO-RAIL IN/OUT | DUALS                   |
|-------------------------|------------------------|-------------------------|------------------|--------------------------------|---------------------|-------------------------|
| <a href="#">OPA836</a>  | 205                    | 560                     | 1                | 4.6                            | –VS/Out             | <a href="#">OPA2836</a> |
| <a href="#">OPA835</a>  | 30                     | 110                     | 0.25             | 9.3                            | –VS/Out             | <a href="#">OPA2835</a> |
| <a href="#">OPA365</a>  | 50                     | 25                      | 5                | 4.5                            | In/Out              | <a href="#">OPA2365</a> |
| <a href="#">THS4281</a> | 95                     | 35                      | 0.75             | 12.5                           | In/Out              | —                       |
| <a href="#">LMH6618</a> | 140                    | 45                      | 1.25             | 10                             | In/Out              | <a href="#">LMH6619</a> |
| <a href="#">OPA830</a>  | 310                    | 600                     | 3.9              | 9.5                            | –VS/Out             | <a href="#">OPA2830</a> |

For a complete selection of TI high-speed amplifiers, visit [www.ti.com](http://www.ti.com).

## 6 Pin Configuration and Functions

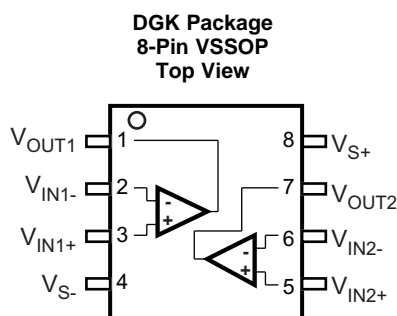

**Pin Functions**

| NAME       | PIN | I/O    | DESCRIPTION                    |
|------------|-----|--------|--------------------------------|
| $V_{IN1+}$ | 3   | Input  | Amplifier 1 noninverting input |
| $V_{IN1-}$ | 2   | Input  | Amplifier 1 inverting input    |
| $V_{IN2+}$ | 5   | Input  | Amplifier 2 noninverting input |
| $V_{IN2-}$ | 6   | Input  | Amplifier 2 inverting input    |
| $V_{OUT1}$ | 1   | Output | Amplifier 1 output             |
| $V_{OUT2}$ | 7   | Output | Amplifier 2 output             |
| $V_{S+}$   | 8   | Power  | Positive power supply input    |
| $V_{S-}$   | 4   | Power  | Negative power supply input    |

## 7 Specifications

### 7.1 Absolute Maximum Ratings

over operating free-air temperature range (unless otherwise noted)<sup>(1)</sup>

|                      |                                | MIN                                     | MAX            | UNIT |
|----------------------|--------------------------------|---|----------------|------|
| $V_{S-}$ to $V_{S+}$ | Supply voltage                 |   | 5.5            | V    |
| $V_I$                | Input voltage                  | $V_{S-} - 0.7$                          | $V_{S+} + 0.7$ | V    |
| $V_{ID}$             | Differential input voltage     |   | 1              | V    |
| $I_I$                | Continuous input current       |   | 0.85           | mA   |
| $I_O$                | Continuous output current      |   | 60             | mA   |
|                      | Continuous power dissipation   | See <a href="#">Thermal Information</a> |                |      |
| $T_J$                | Maximum junction temperature   |   | 150            | °C   |
| $T_A$                | Operating free-air temperature | -40                                     | 125            | °C   |
| $T_{stg}$            | Storage temperature            | -65                                     | 150            | °C   |

- (1) Stresses beyond those listed under *Absolute Maximum Ratings* may cause permanent damage to the device. These are stress ratings only, which do not imply functional operation of the device at these or any other conditions beyond those indicated under *Recommended Operating Conditions*. Exposure to absolute-maximum-rated conditions for extended periods may affect device reliability.

### 7.2 ESD Ratings

|             |                         |   | VALUE | UNIT |
|-------------|-------------------------|---|-------|------|
| $V_{(ESD)}$ | Electrostatic discharge | Human body model (HBM), per AEC Q100-002 <sup>(1)</sup> | ±6000 | V    |
|             |                         | Charged-device model (CDM), per AEC Q100-011            | ±1000 |      |

- (1) AEC Q100-002 indicates that HBM stressing shall be in accordance with the ANSI/ESDA/JEDEC JS-001 specification.

### 7.3 Recommended Operating Conditions

over operating free-air temperature range (unless otherwise noted)

|          |                       | MIN | NOM | MAX | UNIT |
|----------|-----------------------|-----|-----|-----|------|
| $V_{S+}$ | Single supply voltage | 2.5 | 5   | 5.5 | V    |
| $T_A$    | Ambient temperature   | -40 | 25  | 125 | °C   |

### 7.4 Thermal Information

| THERMAL METRIC <sup>(1)</sup> |  | OPA2836-Q1  | UNIT |
|-------------------------------|--|-------------|------|
|                               |  | DGK (VSSOP) |      |
|                               |  | 8 PINS      |      |
| $R_{\theta JA}$               | Junction-to-ambient thermal resistance       | 177.7       | °C/W |
| $R_{\theta Jctop}$            | Junction-to-case (top) thermal resistance    | 69.3        | °C/W |
| $R_{\theta JB}$               | Junction-to-board thermal resistance         | 98.8        | °C/W |
| $\Psi_{JT}$                   | Junction-to-top characterization parameter   | 11.7        | °C/W |
| $\Psi_{JB}$                   | Junction-to-board characterization parameter | 97.2        | °C/W |

- (1) For more information about traditional and new thermal metrics, see the [Semiconductor and IC Package Thermal Metrics](#) application report.

## 7.5 Electrical Characteristics: $V_S = 2.7\text{ V}$

test conditions unless otherwise noted:  $V_{S+} = 2.7\text{ V}$ ,  $V_{S-} = 0\text{ V}$ ,  $V_{OUT} = 1\text{ V}_{PP}$ ,  $R_F = 0\ \Omega$ ,  $R_L = 2\text{ k}\Omega$ ,  $G = 1\text{ V/V}$ , input and output referenced to mid-supply,  $V_{IN\_CM} = \text{mid-supply} - 0.5\text{ V}$ ;  $T_A = 25^\circ\text{C}$  (unless otherwise noted)

| PARAMETER                                 | TEST CONDITIONS   | MIN   | TYP       | MAX  | UNIT                         | TEST LEVEL <sup>(1)</sup> |
|---|---|-------|-----------|------|------------------------------|---------------------------|
| <b>AC PERFORMANCE</b>                     |   |       |           |      |                              |                           |
| Small-signal bandwidth                    | $V_{OUT} = 100\text{ mV}_{PP}$ , $G = 1$  |       | 200       |      | MHz                          | C                         |
|   | $V_{OUT} = 100\text{ mV}_{PP}$ , $G = 2$  |       | 100       |      |                              | C                         |
|   | $V_{OUT} = 100\text{ mV}_{PP}$ , $G = 5$  |       | 26        |      |                              | C                         |
|   | $V_{OUT} = 100\text{ mV}_{PP}$ , $G = 10$   |       | 11        |      |                              | C                         |
| Gain-bandwidth product                    | $V_{OUT} = 100\text{ mV}_{PP}$ , $G = 10$   |       | 110       |      | MHz                          | C                         |
| Large-signal bandwidth                    | $V_{OUT} = 1\text{ V}_{PP}$ , $G = 2$   |       | 60        |      | MHz                          | C                         |
| Bandwidth for 0.1-dB flatness             | $V_{OUT} = 1\text{ V}_{PP}$ , $G = 2$   |       | 25        |      | MHz                          | C                         |
| Slew rate, rise                           | $V_{OUT} = 1\text{ V}_{STEP}$ , $G = 2$   |       | 260       |      | V/ $\mu\text{s}$             | C                         |
| Slew rate, fall                           | $V_{OUT} = 1\text{ V}_{STEP}$ , $G = 2$   |       | 240       |      | V/ $\mu\text{s}$             | C                         |
| Rise time                                 | $V_{OUT} = 1\text{ V}_{STEP}$ , $G = 2$   |       | 4         |      | ns                           | C                         |
| Fall time                                 | $V_{OUT} = 1\text{ V}_{STEP}$ , $G = 2$   |       | 4.5       |      | ns                           | C                         |
| Settling time to 1%, rise                 | $V_{OUT} = 1\text{ V}_{STEP}$ , $G = 2$   |       | 15        |      | ns                           | C                         |
| Settling time to 1%, fall                 | $V_{OUT} = 1\text{ V}_{STEP}$ , $G = 2$   |       | 15        |      | ns                           | C                         |
| Settling time to 0.1%, rise               | $V_{OUT} = 1\text{ V}_{STEP}$ , $G = 2$   |       | 30        |      | ns                           | C                         |
| Settling time to 0.1%, fall               | $V_{OUT} = 1\text{ V}_{STEP}$ , $G = 2$   |       | 25        |      | ns                           | C                         |
| Settling time to 0.01%, rise              | $V_{OUT} = 1\text{ V}_{STEP}$ , $G = 2$   |       | 50        |      | ns                           | C                         |
| Settling time to 0.01%, fall              | $V_{OUT} = 1\text{ V}_{STEP}$ , $G = 2$   |       | 45        |      | ns                           | C                         |
| Overshoot                                 | $V_{OUT} = 1\text{ V}_{STEP}$ , $G = 2$   |       | 5%        |      |                              | C                         |
| Undershoot                                | $V_{OUT} = 1\text{ V}_{STEP}$ , $G = 2$   |       | 3%        |      |                              | C                         |
| Second-order harmonic distortion          | $f = 10\text{ kHz}$ , $V_{IN\_CM} = \text{mid-supply} - 0.5\text{ V}$   |       | -133      |      | dBc                          | C                         |
|   | $f = 100\text{ kHz}$ , $V_{IN\_CM} = \text{mid-supply} - 0.5\text{ V}$  |       | -120      |      |                              | C                         |
|   | $f = 1\text{ MHz}$ , $V_{IN\_CM} = \text{mid-supply} - 0.5\text{ V}$  |       | -84       |      |                              | C                         |
| Third-order harmonic distortion           | $f = 10\text{ kHz}$ , $V_{IN\_CM} = \text{mid-supply} - 0.5\text{ V}$   |       | -137      |      | dBc                          | C                         |
|   | $f = 100\text{ kHz}$ , $V_{IN\_CM} = \text{mid-supply} - 0.5\text{ V}$  |       | -130      |      |                              | C                         |
|   | $f = 1\text{ MHz}$ , $V_{IN\_CM} = \text{mid-supply} - 0.5\text{ V}$  |       | -105      |      |                              | C                         |
| Second-order intermodulation distortion   | $f = 1\text{ MHz}$ , 200-kHz tone spacing,<br>$V_{OUT}$ envelope = $1\text{ V}_{PP}$ ,<br>$V_{IN\_CM} = \text{mid-supply} - 0.5\text{ V}$ |       | -90       |      | dBc                          | C                         |
| Third-order intermodulation distortion    | $f = 1\text{ MHz}$ , 200-kHz tone spacing,<br>$V_{OUT}$ envelope = $1\text{ V}_{PP}$ ,<br>$V_{IN\_CM} = \text{mid-supply} - 0.5\text{ V}$ |       | -90       |      | dBc                          | C                         |
| Input voltage noise                       | $f = 100\text{ kHz}$  |       | 4.6       |      | nV/ $\sqrt{\text{Hz}}$       | C                         |
| Voltage noise 1/f corner frequency        |   |       | 215       |      | Hz                           | C                         |
| Input current noise                       | $f = 1\text{ MHz}$  |       | 0.75      |      | pA/ $\sqrt{\text{Hz}}$       | C                         |
| Current noise 1/f corner frequency        |   |       | 31.7      |      | kHz                          | C                         |
| Overdrive recovery time                   | Overdrive = $0.5\text{ V}$  |       | 55        |      | ns                           | C                         |
| Underdrive recovery time                  | Underdrive = $0.5\text{ V}$   |       | 60        |      | ns                           | C                         |
| Closed-loop output impedance              | $f = 100\text{ kHz}$  |       | 0.02      |      | $\Omega$                     | C                         |
| Channel-to-channel crosstalk              | $f = 10\text{ kHz}$   |       | -120      |      | dB                           | C                         |
| <b>DC PERFORMANCE</b>                     |   |       |           |      |                              |                           |
| Open-loop voltage gain ( $A_{OL}$ )       |   | 100   | 125       |      | dB                           | A                         |
| Input-referred offset voltage             | $T_A = 25^\circ\text{C}$  | -400  | $\pm 65$  | 400  | $\mu\text{V}$                | A                         |
|   | $T_A = -40^\circ\text{C}$ to $+85^\circ\text{C}$  | -760  |           | 760  |                              | B                         |
|   | $T_A = -40^\circ\text{C}$ to $+125^\circ\text{C}$   | -1060 |           | 1060 |                              | B                         |
| Input offset voltage drift <sup>(2)</sup> | $T_A = -40^\circ\text{C}$ to $+85^\circ\text{C}$  | -6    | $\pm 1$   | 6    | $\mu\text{V}/^\circ\text{C}$ | B                         |
|   | $T_A = -40^\circ\text{C}$ to $+125^\circ\text{C}$   | -6.6  | $\pm 1.1$ | 6.6  |                              | B                         |

- (1) Test levels (all values set by characterization and simulation): **(A)** 100% tested at  $25^\circ\text{C}$ ; over temperature limits by characterization and simulation. **(B)** Not tested in production; limits set by characterization and simulation. **(C)** Typical value only for information.
- (2) Input offset voltage drift, input bias current drift, and input offset current drift are average values calculated by taking data at the end points, computing the difference, and dividing by the temperature range.

**Electrical Characteristics:  $V_S = 2.7\text{ V}$  (continued)**

test conditions unless otherwise noted:  $V_{S+} = 2.7\text{ V}$ ,  $V_{S-} = 0\text{ V}$ ,  $V_{OUT} = 1\text{ V}_{PP}$ ,  $R_F = 0\ \Omega$ ,  $R_L = 2\text{ k}\Omega$ ,  $G = 1\text{ V/V}$ , input and output referenced to mid-supply,  $V_{IN\_CM} = \text{mid-supply} - 0.5\text{ V}$ ;  $T_A = 25^\circ\text{C}$  (unless otherwise noted)

| PARAMETER                                  | TEST CONDITIONS  | MIN      | TYP             | MAX  | UNIT             | TEST LEVEL <sup>(1)</sup> |
|--|--|----------|-----------------|------|------------------|---------------------------|
| <b>DC PERFORMANCE (continued)</b>          |  |          |                 |      |                  |                           |
| Input bias current <sup>(3)</sup>          | $T_A = 25^\circ\text{C}$   | 200      | 650             | 1000 | nA               | A                         |
|  | $T_A = -40^\circ\text{C}$ to $+85^\circ\text{C}$                                       | 120      |                 | 1500 |                  | B                         |
|  | $T_A = -40^\circ\text{C}$ to $+125^\circ\text{C}$                                      | 100      |                 | 1800 |                  | B                         |
| Input bias current drift <sup>(2)</sup>    | $T_A = -40^\circ\text{C}$ to $+85^\circ\text{C}$                                       | -1.9     | $\pm 0.32$      | 1.9  | nA/°C            | B                         |
|  | $T_A = -40^\circ\text{C}$ to $+125^\circ\text{C}$                                      | -3.5     | $\pm 0.37$      | 2.1  |                  | B                         |
| Input offset current                       | $T_A = 25^\circ\text{C}$   | -180     | $\pm 30$        | 180  | nA               | A                         |
|  | $T_A = -40^\circ\text{C}$ to $+85^\circ\text{C}$                                       | -215     | $\pm 30$        | 215  |                  | B                         |
|  | $T_A = -40^\circ\text{C}$ to $+125^\circ\text{C}$                                      | -240     | $\pm 30$        | 240  |                  | B                         |
| Input offset current drift <sup>(2)</sup>  | $T_A = -40^\circ\text{C}$ to $+85^\circ\text{C}$                                       | -575     | $\pm 95$        | 575  | pA/°C            | B                         |
|  | $T_A = -40^\circ\text{C}$ to $+125^\circ\text{C}$                                      | -600     | $\pm 100$       | 600  |                  | B                         |
| <b>INPUT</b>                               |  |          |                 |      |                  |                           |
| Common-mode input range, low               | $T_A = 25^\circ\text{C}$ ,<br>< 3-dB degradation in CMRR limit                         |          | -0.2            | 0    | V                | A                         |
|  | $T_A = -40^\circ\text{C}$ to $125^\circ\text{C}$ ,<br>< 3-dB degradation in CMRR limit |          | -0.2            | 0    | V                | B                         |
| Common-mode input range, high              | $T_A = 25^\circ\text{C}$ ,<br>< 3-dB degradation in CMRR limit                         | 1.5      | 1.6             |      | V                | A                         |
|  | $T_A = -40^\circ\text{C}$ to $125^\circ\text{C}$ ,<br>< 3-dB degradation in CMRR limit | 1.5      | 1.6             |      | V                | B                         |
| Input linear operating voltage range       | $T_A = 25^\circ\text{C}$ ,<br>< 6-dB degradation in THD                                |          | -0.3 to<br>1.75 |      | V                | C                         |
| Common-mode rejection ratio                |  | 91       | 114             |      | dB               | A                         |
| Input impedance common-mode                |  |          | 200    1.2      |      | k $\Omega$    pF | C                         |
| Input impedance differential mode          |  |          | 200    1        |      | k $\Omega$    pF | C                         |
| <b>OUTPUT</b>                              |  |          |                 |      |                  |                           |
| Output voltage, low                        | $T_A = 25^\circ\text{C}$ , $G = 5$   |          | 0.15            | 0.2  | V                | A                         |
|  | $T_A = -40^\circ\text{C}$ to $+125^\circ\text{C}$ , $G = 5$                            |          | 0.15            | 0.2  | V                | B                         |
| Output voltage, high                       | $T_A = 25^\circ\text{C}$ , $G = 5$   | 2.45     | 2.5             |      | V                | A                         |
|  | $T_A = -40^\circ\text{C}$ to $+125^\circ\text{C}$ , $G = 5$                            | 2.45     | 2.5             |      | V                | B                         |
| Output saturation voltage, high            | $T_A = 25^\circ\text{C}$ , $G = 5$   |          | 80              |      | mV               | C                         |
| Output saturation voltage, low             | $T_A = 25^\circ\text{C}$ , $G = 5$   |          | 40              |      | mV               | C                         |
| Output current drive                       | $T_A = 25^\circ\text{C}$   | $\pm 40$ | $\pm 45$        |      | mA               | A                         |
|  | $T_A = -40^\circ\text{C}$ to $+125^\circ\text{C}$                                      | $\pm 40$ | $\pm 45$        |      | mA               | B                         |
| <b>POWER SUPPLY</b>                        |  |          |                 |      |                  |                           |
| Specified operating voltage                |  | 2.5      |                 | 5.5  | V                | B                         |
| Quiescent operating current per amplifier  | $T_A = 25^\circ\text{C}$   | 0.7      | 0.95            | 1.15 | mA               | A                         |
|  | $T_A = -40^\circ\text{C}$ to $+125^\circ\text{C}$                                      | 0.6      |                 | 1.6  | mA               | B                         |
| Power-supply rejection ratio ( $\pm$ PSRR) |  | 91       | 108             |      | dB               | A                         |

(3) Current is considered positive out of the pin.

## 7.6 Electrical Characteristics: $V_S = 5\text{ V}$

test conditions unless otherwise noted:  $V_{S+} = 5\text{ V}$ ,  $V_{S-} = 0\text{ V}$ ,  $V_{OUT} = 2\text{ V}_{PP}$ ,  $R_F = 0\ \Omega$ ,  $R_L = 1\text{ k}\Omega$ ,  $G = 1\text{ V/V}$ , input and output referenced to mid-supply;  $T_A = 25^\circ\text{C}$  (unless otherwise noted)

| PARAMETER                               | TEST CONDITIONS  | MIN   | TYP      | MAX  | UNIT                   | TEST LEVEL <sup>(1)</sup> |
|---|--|-------|----------|------|------------------------|---------------------------|
| <b>AC PERFORMANCE</b>                   |  |       |          |      |                        |                           |
| Small-signal bandwidth                  | $V_{OUT} = 100\text{ mV}_{PP}$ , $G = 1$   |       | 205      |      | MHz                    | C                         |
|   | $V_{OUT} = 100\text{ mV}_{PP}$ , $G = 2$   |       | 100      |      |                        | C                         |
|   | $V_{OUT} = 100\text{ mV}_{PP}$ , $G = 5$   |       | 28       |      |                        | C                         |
|   | $V_{OUT} = 100\text{ mV}_{PP}$ , $G = 10$  |       | 11.8     |      |                        | C                         |
| Gain-bandwidth product                  | $V_{OUT} = 100\text{ mV}_{PP}$ , $G = 10$  |       | 118      |      | MHz                    | C                         |
| Large-signal bandwidth                  | $V_{OUT} = 2\text{ V}_{PP}$ , $G = 2$  |       | 87       |      | MHz                    | C                         |
| Bandwidth for 0.1-dB flatness           | $V_{OUT} = 2\text{ V}_{PP}$ , $G = 2$  |       | 29       |      | MHz                    | C                         |
| Slew rate, rise                         | $V_{OUT} = 2\text{-V step}$ , $G = 2$  |       | 560      |      | V/ $\mu\text{s}$       | C                         |
| Slew rate, fall                         | $V_{OUT} = 2\text{-V step}$ , $G = 2$  |       | 580      |      | V/ $\mu\text{s}$       | C                         |
| Rise time                               | $V_{OUT} = 2\text{-V step}$ , $G = 2$  |       | 3        |      | ns                     | C                         |
| Fall time                               | $V_{OUT} = 2\text{-V Step}$ , $G = 2$  |       | 3        |      | ns                     | C                         |
| Settling time to 1%, rise               | $V_{OUT} = 2\text{-V step}$ , $G = 2$  |       | 22       |      | ns                     | C                         |
| Settling time to 1%, fall               | $V_{OUT} = 2\text{-V step}$ , $G = 2$  |       | 22       |      | ns                     | C                         |
| Settling time to 0.1%, rise             | $V_{OUT} = 2\text{-V step}$ , $G = 2$  |       | 30       |      | ns                     | C                         |
| Settling time to 0.1%, fall             | $V_{OUT} = 2\text{-V step}$ , $G = 2$  |       | 30       |      | ns                     | C                         |
| Settling time to 0.01%, rise            | $V_{OUT} = 2\text{-V step}$ , $G = 2$  |       | 40       |      | ns                     | C                         |
| Settling time to 0.01%, fall            | $V_{OUT} = 2\text{-V step}$ , $G = 2$  |       | 45       |      | ns                     | C                         |
| Overshoot                               | $V_{OUT} = 2\text{-V step}$ , $G = 2$  |       | 7.5%     |      |                        | C                         |
| Undershoot                              | $V_{OUT} = 2\text{-V step}$ , $G = 2$  |       | 5%       |      |                        | C                         |
| Second-order harmonic distortion        | $f = 10\text{ kHz}$  |       | -133     |      | dBc                    | C                         |
|   | $f = 100\text{ kHz}$   |       | -120     |      |                        | C                         |
|   | $f = 1\text{ MHz}$   |       | -85      |      |                        | C                         |
| Third-order harmonic distortion         | $f = 10\text{ kHz}$  |       | -140     |      | dBc                    | C                         |
|   | $f = 100\text{ kHz}$   |       | -130     |      |                        | C                         |
|   | $f = 1\text{ MHz}$   |       | -105     |      |                        | C                         |
| Second-order intermodulation distortion | $f = 1\text{ MHz}$ , 200-kHz tone spacing,<br>$V_{OUT}$ envelope = $2\text{ V}_{PP}$ |       | -79      |      | dBc                    | C                         |
| Third-order intermodulation distortion  | $f = 1\text{ MHz}$ , 200-kHz tone spacing,<br>$V_{OUT}$ envelope = $2\text{ V}_{PP}$ |       | -91      |      | dBc                    | C                         |
| Signal-to-noise ratio (SNR)             | $f = 1\text{ kHz}$ , $V_{OUT} = 1\text{ V}_{RMS}$ ,<br>22-kHz bandwidth              |       | 0.00013% |      |                        | C                         |
|   |  |       | -117.6   |      | dBc                    | C                         |
| Total harmonic distortion (THD)         | $f = 1\text{ kHz}$ , $V_{OUT} = 1\text{ V}_{RMS}$                                    |       | 0.00003% |      |                        | C                         |
|   |  |       | -130     |      | dBc                    | C                         |
| Input voltage noise                     | $f = 100\text{ KHz}$   |       | 4.6      |      | nV/ $\sqrt{\text{Hz}}$ | C                         |
| Voltage noise 1/f corner frequency      |  |       | 215      |      | Hz                     | C                         |
| Input current noise                     | $f > 1\text{ MHz}$   |       | 0.75     |      | pA/ $\sqrt{\text{Hz}}$ | C                         |
| Current noise 1/f corner frequency      |  |       | 31.7     |      | kHz                    | C                         |
| Overdrive recovery time                 | Overdrive = 0.5 V  |       | 55       |      | ns                     | C                         |
| Underdrive recovery time                | Underdrive = 0.5 V   |       | 60       |      | ns                     | C                         |
| Closed-loop output impedance            | $f = 100\text{ kHz}$   |       | 0.02     |      | $\Omega$               | C                         |
| Channel-to-channel crosstalk            | $f = 10\text{ kHz}$  |       | -120     |      | dB                     | C                         |
| <b>DC PERFORMANCE</b>                   |  |       |          |      |                        |                           |
| Open-loop voltage gain ( $A_{OL}$ )     |  | 100   | 122      |      | dB                     | A                         |
| Input-referred offset voltage           | $T_A = 25^\circ\text{C}$   | -400  | $\pm 65$ | 400  | $\mu\text{V}$          | A                         |
|   | $T_A = -40^\circ\text{C}$ to $+85^\circ\text{C}$                                     | -765  |          | 765  |                        | B                         |
|   | $T_A = -40^\circ\text{C}$ to $+125^\circ\text{C}$                                    | -1080 |          | 1080 |                        | B                         |

(1) Test levels (all values set by characterization and simulation): **(A)** 100% tested at  $25^\circ\text{C}$ ; over temperature limits by characterization and simulation. **(B)** Not tested in production; limits set by characterization and simulation. **(C)** Typical value only for information.

**Electrical Characteristics:  $V_S = 5\text{ V}$  (continued)**

 test conditions unless otherwise noted:  $V_{S+} = 5\text{ V}$ ,  $V_{S-} = 0\text{ V}$ ,  $V_{OUT} = 2 V_{PP}$ ,  $R_F = 0\ \Omega$ ,  $R_L = 1\text{ k}\Omega$ ,  $G = 1\text{ V/V}$ , input and output referenced to mid-supply;  $T_A = 25^\circ\text{C}$  (unless otherwise noted)

| PARAMETER   | TEST CONDITIONS  | MIN      | TYP             | MAX       | UNIT                         | TEST LEVEL <sup>(1)</sup> |
|---|--|----------|-----------------|-----------|------------------------------|---------------------------|
| <b>DC PERFORMANCE (continued)</b>                 |  |          |                 |           |                              |                           |
| Input offset voltage drift <sup>(2)</sup>         | $T_A = -40^\circ\text{C}$ to $+85^\circ\text{C}$                                       | -6.1     | $\pm 1$         | 6.1       | $\mu\text{V}/^\circ\text{C}$ | B                         |
|   | $T_A = -40^\circ\text{C}$ to $+125^\circ\text{C}$                                      | -6.8     | $\pm 1.1$       | 6.8       |                              | B                         |
| Input bias current <sup>(3)</sup>                 | $T_A = 25^\circ\text{C}$   | 200      | 650             | 1000      | nA                           | A                         |
|   | $T_A = -40^\circ\text{C}$ to $+85^\circ\text{C}$                                       | 120      |                 | 1550      |                              | B                         |
|   | $T_A = -40^\circ\text{C}$ to $+125^\circ\text{C}$                                      | 100      |                 | 1850      |                              | B                         |
| Input bias current drift <sup>(2)</sup>           | $T_A = -40^\circ\text{C}$ to $+85^\circ\text{C}$                                       |          | $\pm 0.34$      | $\pm 2$   | nA/ $^\circ\text{C}$         | B                         |
|   | $T_A = -40^\circ\text{C}$ to $+125^\circ\text{C}$                                      |          | $\pm 0.38$      | $\pm 3.8$ |                              | B                         |
| Input offset current                              | $T_A = 25^\circ\text{C}$   |          | $\pm 30$        | $\pm 180$ | nA                           | A                         |
|   | $T_A = -40^\circ\text{C}$ to $+85^\circ\text{C}$                                       |          | $\pm 30$        | $\pm 215$ |                              | B                         |
|   | $T_A = -40^\circ\text{C}$ to $+125^\circ\text{C}$                                      |          | $\pm 30$        | $\pm 250$ |                              | B                         |
| Input offset current drift <sup>(2)</sup>         | $T_A = -40^\circ\text{C}$ to $+85^\circ\text{C}$                                       |          | $\pm 100$       | $\pm 600$ | pA/ $^\circ\text{C}$         | B                         |
|   | $T_A = -40^\circ\text{C}$ to $+125^\circ\text{C}$                                      |          | $\pm 110$       | $\pm 660$ |                              | B                         |
| <b>INPUT</b>                                      |  |          |                 |           |                              |                           |
| Common-mode input range low                       | $T_A = 25^\circ\text{C}$ ,<br>< 3-dB degradation in CMRR limit                         |          | -0.2            | 0         | V                            | A                         |
|   | $T_A = -40^\circ\text{C}$ to $125^\circ\text{C}$ ,<br>< 3-dB degradation in CMRR limit |          | -0.2            | 0         | V                            | B                         |
| Common-mode input range high                      | $T_A = 25^\circ\text{C}$ ,<br>< 3-dB degradation in CMRR limit                         | 3.8      | 3.9             |           | V                            | A                         |
|   | $T_A = -40^\circ\text{C}$ to $125^\circ\text{C}$ ,<br>< 3-dB degradation in CMRR limit | 3.8      | 3.9             |           | V                            | B                         |
| Input linear operating voltage range              | $T_A = 25^\circ\text{C}$ ,<br>< 6-dB degradation in THD                                |          | -0.3 to<br>4.05 |           | V                            | C                         |
| Common-mode rejection ratio                       |  | 94       | 116             |           | dB                           | A                         |
| Input impedance common mode                       |  |          | 200    1.2      |           | k $\Omega$    pF             | C                         |
| Input impedance differential mode                 |  |          | 200    1        |           | k $\Omega$    pF             | C                         |
| <b>OUTPUT</b>                                     |  |          |                 |           |                              |                           |
| Output voltage low                                | $T_A = 25^\circ\text{C}$ , $G = 5$   |          | 0.15            | 0.2       | V                            | A                         |
|   | $T_A = -40^\circ\text{C}$ to $+125^\circ\text{C}$ , $G = 5$                            |          | 0.15            | 0.2       | V                            | B                         |
| Output voltage high                               | $T_A = 25^\circ\text{C}$ , $G = 5$   | 4.75     | 4.8             |           | V                            | A                         |
|   | $T_A = -40^\circ\text{C}$ to $+125^\circ\text{C}$ , $G = 5$                            | 4.75     | 4.8             |           | V                            | B                         |
| Output saturation voltage, high                   | $T_A = 25^\circ\text{C}$ , $G = 5$   |          | 100             |           | mV                           | C                         |
| Output saturation voltage, low                    | $T_A = 25^\circ\text{C}$ , $G = 5$   |          | 50              |           | mV                           | C                         |
| Output current drive                              | $T_A = 25^\circ\text{C}$   | $\pm 40$ | $\pm 50$        |           | mA                           | A                         |
|   | $T_A = -40^\circ\text{C}$ to $+125^\circ\text{C}$                                      | $\pm 40$ | $\pm 50$        |           | mA                           | B                         |
| <b>POWER SUPPLY</b>                               |  |          |                 |           |                              |                           |
| Specified operating voltage                       |  | 2.5      |                 | 5.5       | V                            | B                         |
| Quiescent operating current per amplifier         | $T_A = 25^\circ\text{C}$   | 0.8      | 1.0             | 1.2       | mA                           | A                         |
|   | $T_A = -40^\circ\text{C}$ to $+125^\circ\text{C}$                                      | 0.65     |                 | 1.7       | mA                           | B                         |
| Power-supply rejection ratio ( $\pm\text{PSRR}$ ) |  | 94       | 108             |           | dB                           | A                         |

- (2) Input offset voltage drift, input bias current drift, and input offset current drift are average values calculated by taking data at the end points, computing the difference, and dividing by the temperature range.
- (3) Current is considered positive out of the pin.



## 7.7 Typical Characteristics

### 7.7.1 Typical Characteristics: $V_S = 2.7\text{ V}$

test conditions unless otherwise noted:  $V_{S+} = 2.7\text{ V}$ ,  $V_{S-} = 0\text{ V}$ ,  $V_{OUT} = 1\text{ V}_{PP}$ ,  $R_F = 0\ \Omega$ ,  $R_L = 2\text{ k}\Omega$ ,  $G = 1\text{ V/V}$ , input and output referenced to mid-supply,  $V_{IN\_CM} = \text{mid-supply} - 0.5\text{ V}$ ;  $T_A = 25^\circ\text{C}$  (unless otherwise noted)

**Table 1. Table of Graphs**

| FIGURE TITLE  | FIGURE LOCATION           |
|---|---------------------------|
| Small-Signal Frequency Response                         | <a href="#">Figure 1</a>  |
| Large-Signal Frequency Response                         | <a href="#">Figure 2</a>  |
| Noninverting Pulse Response                             | <a href="#">Figure 3</a>  |
| Inverting Pulse Response                                | <a href="#">Figure 4</a>  |
| Slew Rate vs Output Voltage Step                        | <a href="#">Figure 5</a>  |
| Output Overdrive Recovery                               | <a href="#">Figure 6</a>  |
| Harmonic Distortion vs Frequency                        | <a href="#">Figure 7</a>  |
| Harmonic Distortion vs Load Resistance                  | <a href="#">Figure 8</a>  |
| Harmonic Distortion vs Output Voltage                   | <a href="#">Figure 9</a>  |
| Harmonic Distortion vs Gain                             | <a href="#">Figure 10</a> |
| Output Voltage Swing vs Load Resistance                 | <a href="#">Figure 11</a> |
| Output Saturation Voltage vs Load Current               | <a href="#">Figure 12</a> |
| Output Impedance vs Frequency                           | <a href="#">Figure 13</a> |
| Frequency Response With Capacitive Load                 | <a href="#">Figure 14</a> |
| Series Output Resistor vs Capacitive Load               | <a href="#">Figure 17</a> |
| Input-Referred Noise vs Frequency                       | <a href="#">Figure 16</a> |
| Open-Loop Gain vs Frequency                             | <a href="#">Figure 15</a> |
| Common-Mode, Power-Supply Rejection Ratios vs Frequency | <a href="#">Figure 18</a> |
| Crosstalk vs Frequency                                  | <a href="#">Figure 19</a> |
| Input Offset Voltage                                    | <a href="#">Figure 22</a> |
| Input Offset Voltage vs Free-Air Temperature            | <a href="#">Figure 20</a> |
| Input Offset Voltage Drift                              | <a href="#">Figure 46</a> |
| Input Offset Current                                    | <a href="#">Figure 23</a> |
| Input Offset Current vs Free-Air Temperature            | <a href="#">Figure 24</a> |
| Input Offset Current Drift                              | <a href="#">Figure 25</a> |

test conditions unless otherwise noted:  $V_{S+} = 2.7\text{ V}$ ,  $V_{S-} = 0\text{ V}$ ,  $V_{OUT} = 1\text{ V}_{PP}$ ,  $R_F = 0\ \Omega$ ,  $R_L = 2\text{ k}\Omega$ ,  $G = 1\text{ V/V}$ , input and output referenced to mid-supply,  $V_{IN\_CM} = \text{mid-supply} - 0.5\text{ V}$ ;  $T_A = 25^\circ\text{C}$  (unless otherwise noted)

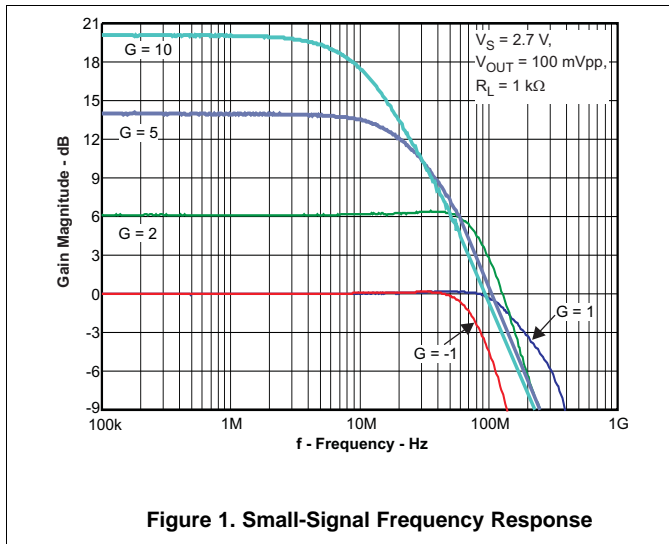

Figure 1. Small-Signal Frequency Response

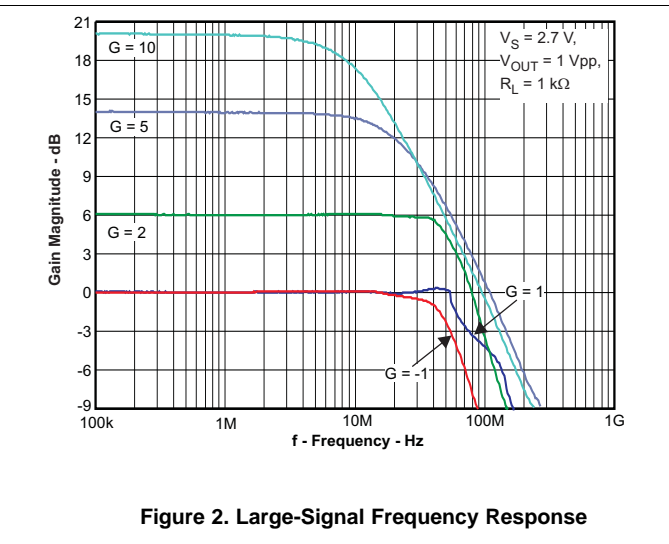

Figure 2. Large-Signal Frequency Response

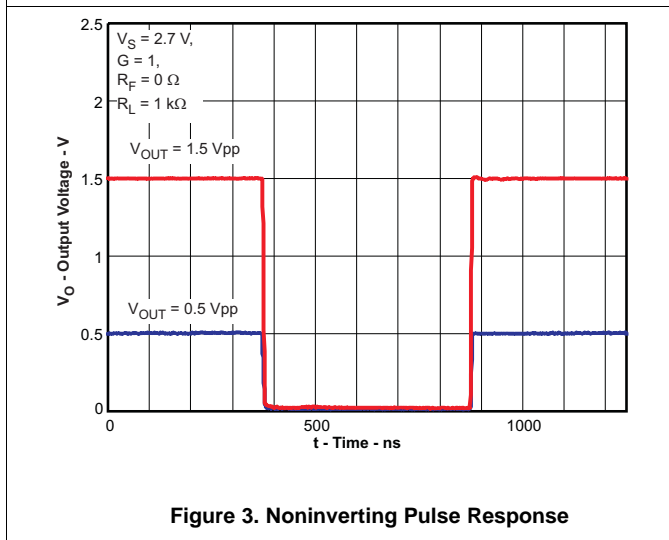

Figure 3. Noninverting Pulse Response

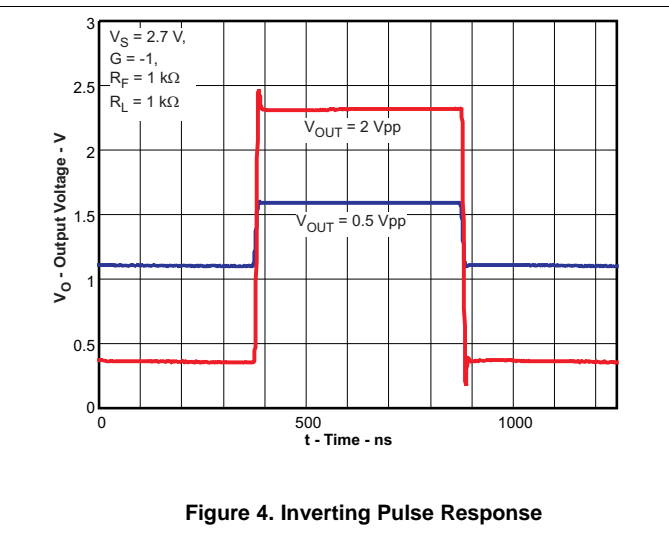

Figure 4. Inverting Pulse Response

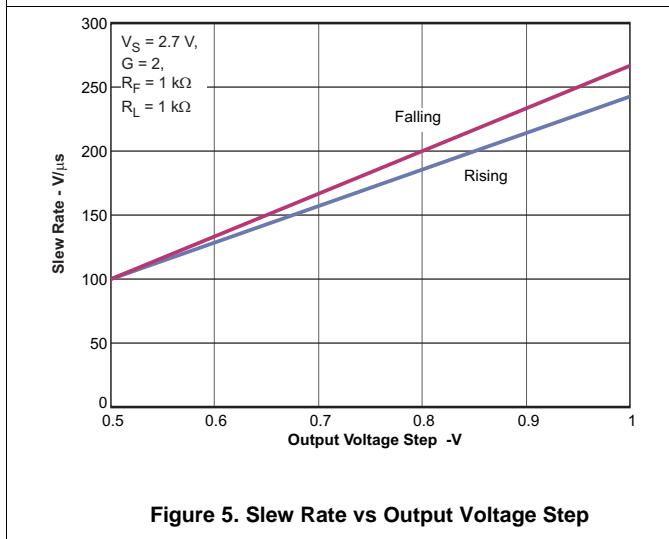

Figure 5. Slew Rate vs Output Voltage Step

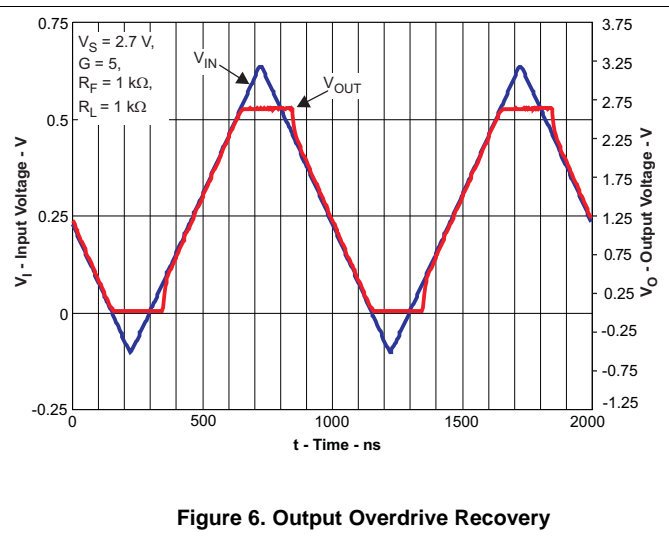

Figure 6. Output Overdrive Recovery

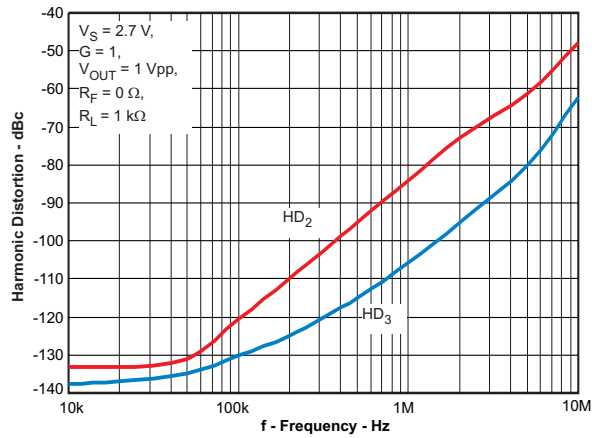

Figure 7. Harmonic Distortion vs Frequency

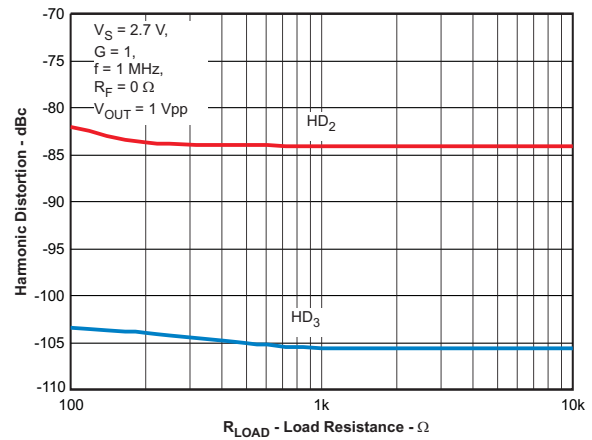

Figure 8. Harmonic Distortion vs Load Resistance

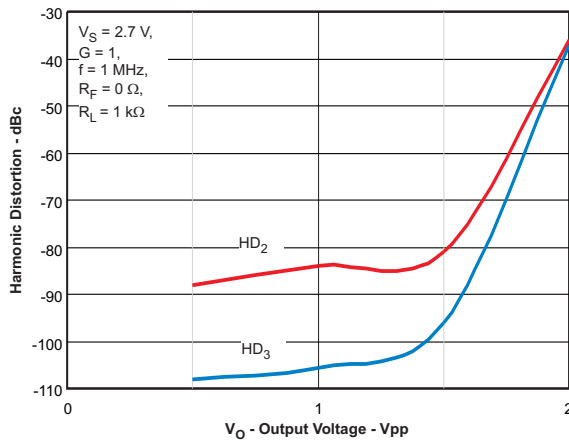

Figure 9. Harmonic Distortion vs Output Voltage

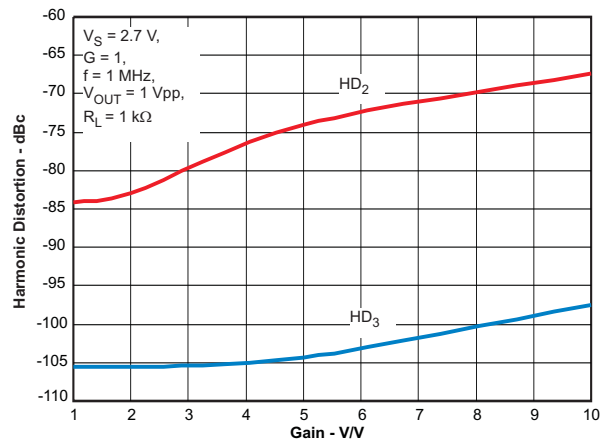

Figure 10. Harmonic Distortion vs Gain

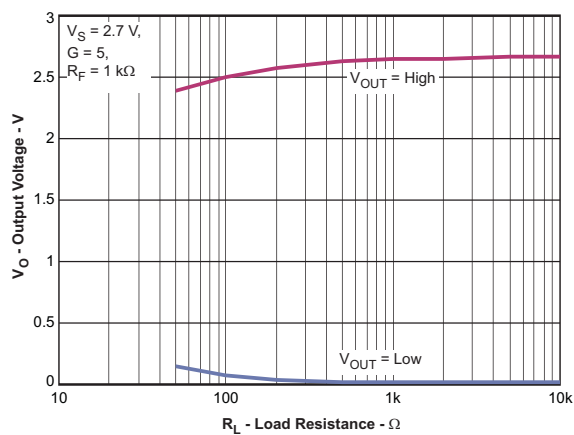

Figure 11. Output Voltage Swing vs Load Resistance

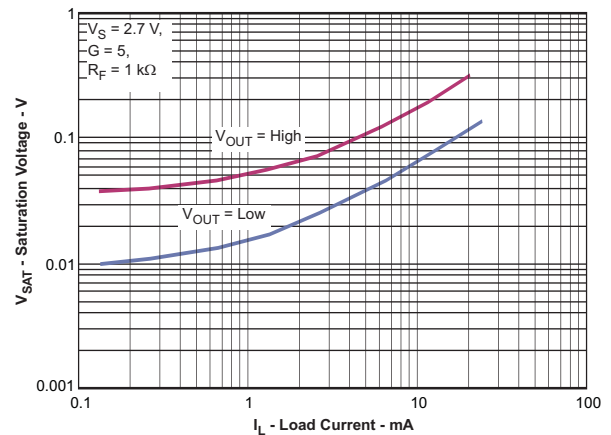

Figure 12. Output Saturation Voltage vs Load Current

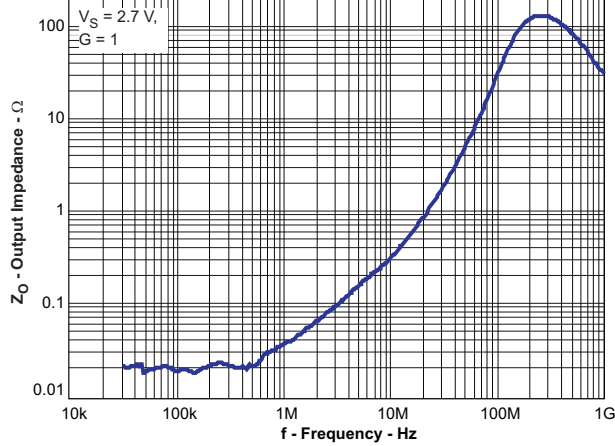

Figure 13. Output Impedance vs Frequency

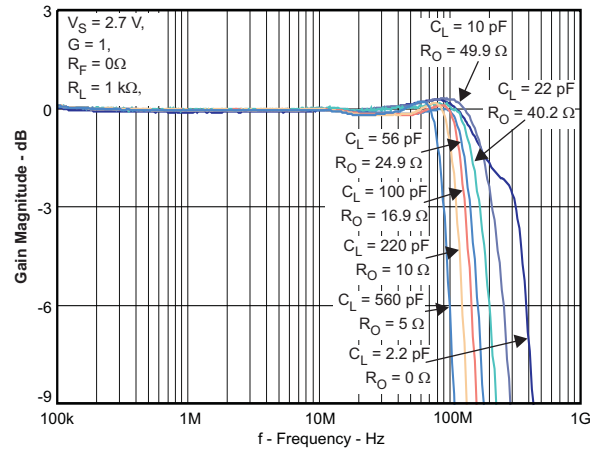

Figure 14. Frequency Response With Capacitive Load

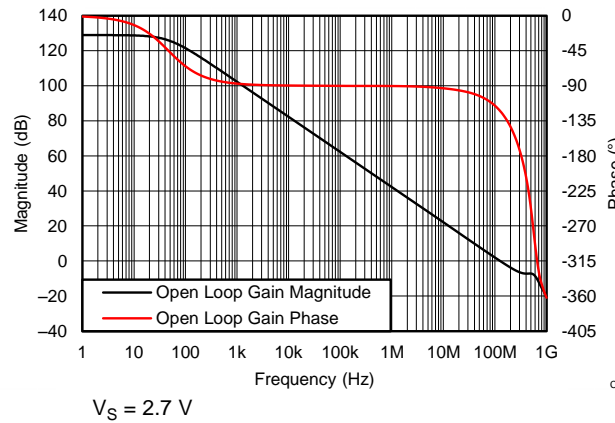

Figure 15. Open-Loop Gain vs Frequency

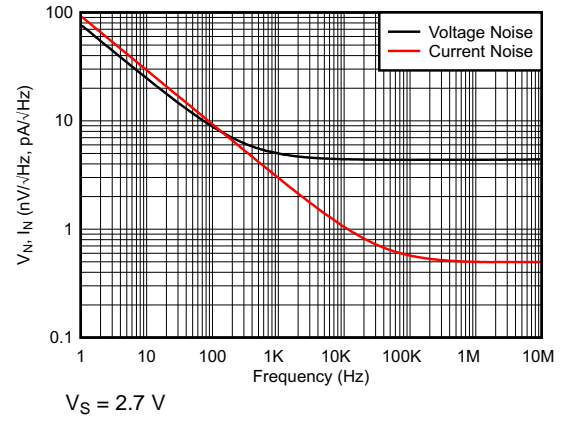

Figure 16. Input-Referred Noise vs Frequency

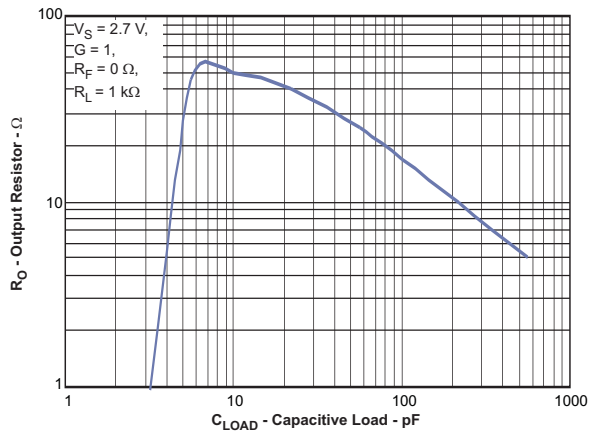

Figure 17. Series Output Resistor vs Capacitive Load

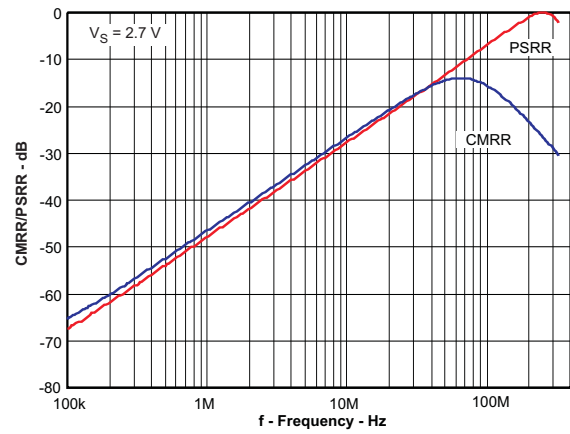

Figure 18. Common-Mode, Power-Supply Rejection Ratios vs Frequency

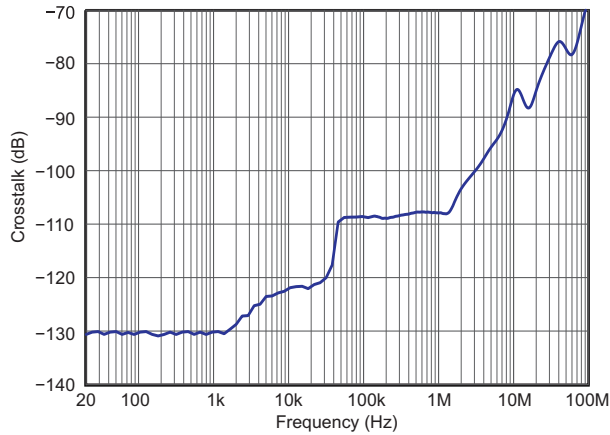

Figure 19. Crosstalk vs Frequency

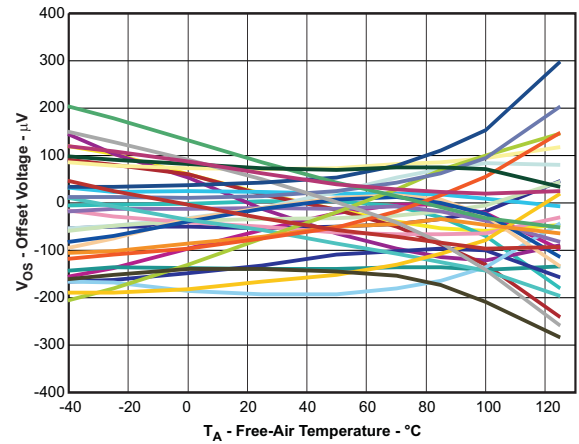

Figure 20. Input Offset Voltage vs Free-Air Temperature

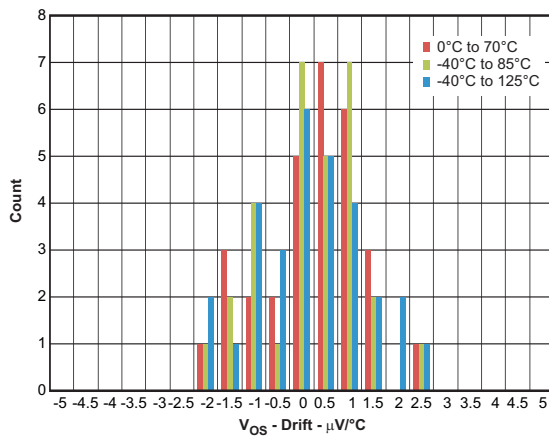

Figure 21. Input Offset Voltage Drift

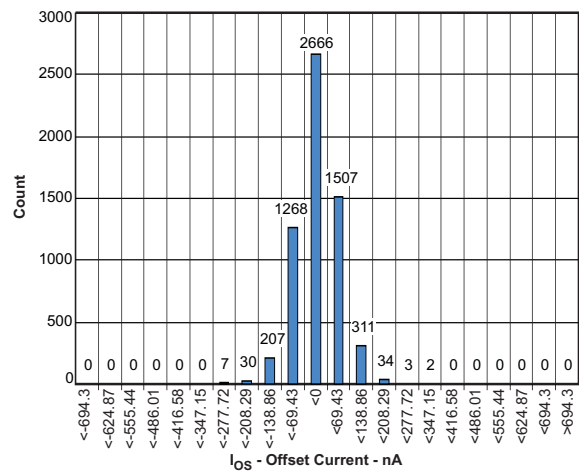

Figure 22. Input Offset Current

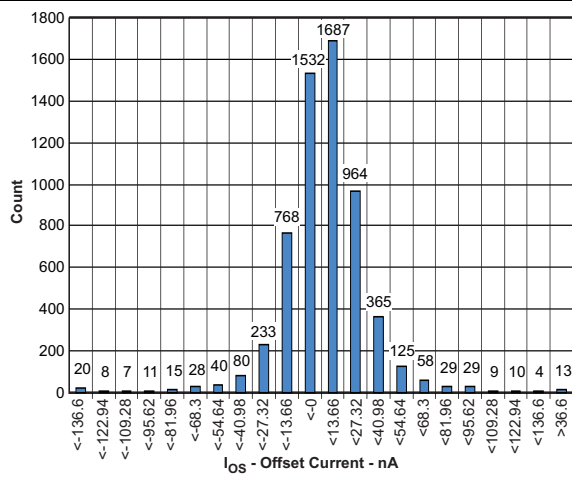

Figure 23. Input Offset Current

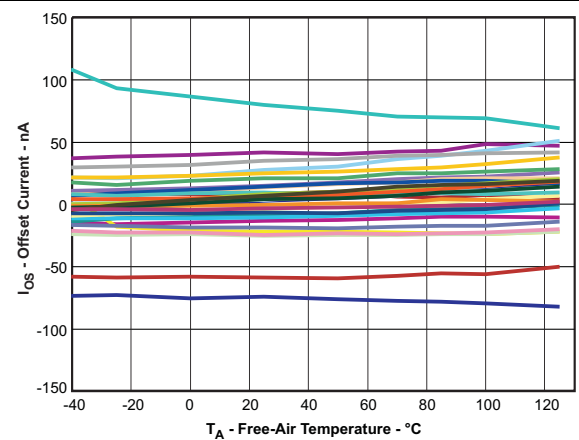
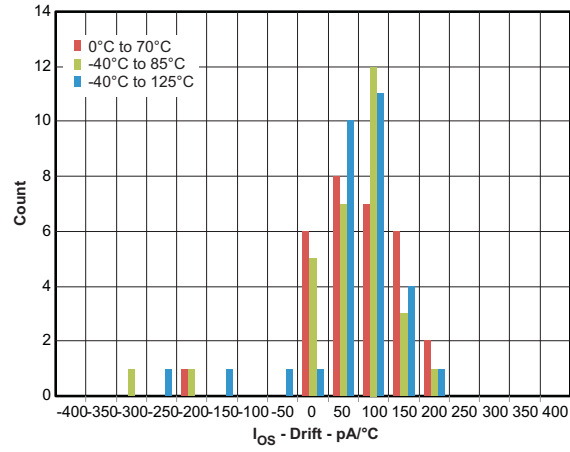

Figure 24. Input Offset Current vs Free-Air Temperature



**Figure 25. Input Offset Current Drift**

### 7.7.2 Typical Characteristics: $V_S = 5\text{ V}$

test conditions unless otherwise noted:  $V_{S+} = 5\text{ V}$ ,  $V_{S-} = 0\text{ V}$ ,  $V_{OUT} = 2\text{ V}_{PP}$ ,  $R_F = 0\ \Omega$ ,  $R_L = 1\text{ k}\Omega$ ,  $G = 1\text{ V/V}$ , input and output referenced to mid-supply;  $T_A = 25^\circ\text{C}$  (unless otherwise noted)

**Table 2. Table of Graphs**

| FIGURE TITLE  | FIGURE LOCATION           |
|---|---------------------------|
| Small-Signal Frequency Response                         | <a href="#">Figure 26</a> |
| Large-Signal Frequency Response                         | <a href="#">Figure 27</a> |
| Noninverting Pulse Response                             | <a href="#">Figure 28</a> |
| Inverting Pulse Response                                | <a href="#">Figure 29</a> |
| Slew Rate vs Output Voltage Step                        | <a href="#">Figure 30</a> |
| Output Overdrive Recovery                               | <a href="#">Figure 31</a> |
| Harmonic Distortion vs Frequency                        | <a href="#">Figure 32</a> |
| Harmonic Distortion vs Load Resistance                  | <a href="#">Figure 33</a> |
| Harmonic Distortion vs Output Voltage                   | <a href="#">Figure 34</a> |
| Harmonic Distortion vs Gain                             | <a href="#">Figure 35</a> |
| Output Voltage Swing vs Load Resistance                 | <a href="#">Figure 36</a> |
| Output Saturation Voltage vs Load Current               | <a href="#">Figure 37</a> |
| Output Impedance vs Frequency                           | <a href="#">Figure 38</a> |
| Frequency Response With Capacitive Load                 | <a href="#">Figure 39</a> |
| Series Output Resistor vs Capacitive Load               | <a href="#">Figure 42</a> |
| Input-Referred Noise vs Frequency                       | <a href="#">Figure 40</a> |
| Open-Loop Gain vs Frequency                             | <a href="#">Figure 41</a> |
| Common-Mode, Power-Supply Rejection Ratios vs Frequency | <a href="#">Figure 43</a> |
| Crosstalk vs Frequency                                  | <a href="#">Figure 44</a> |
| Input Offset Voltage                                    | <a href="#">Figure 47</a> |
| Input Offset Voltage vs Free-Air Temperature            | <a href="#">Figure 45</a> |
| Input Offset Voltage Drift                              | <a href="#">Figure 46</a> |
| Input Offset Current                                    | <a href="#">Figure 48</a> |
| Input Offset Current vs Free-Air Temperature            | <a href="#">Figure 49</a> |
| Input Offset Current Drift                              | <a href="#">Figure 50</a> |

test conditions unless otherwise noted:  $V_{S+} = 5\text{ V}$ ,  $V_{S-} = 0\text{ V}$ ,  $V_{OUT} = 2\text{ V}_{PP}$ ,  $R_F = 0\ \Omega$ ,  $R_L = 1\text{ k}\Omega$ ,  $G = 1\text{ V/V}$ , input and output referenced to mid-supply;  $T_A = 25^\circ\text{C}$  (unless otherwise noted)

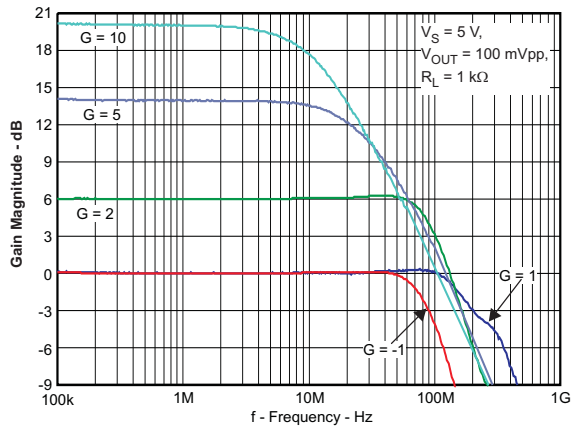

Figure 26. Small-Signal Frequency Response

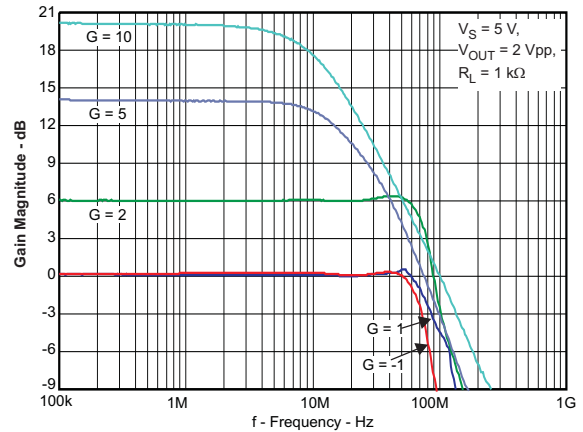

Figure 27. Large-Signal Frequency Response

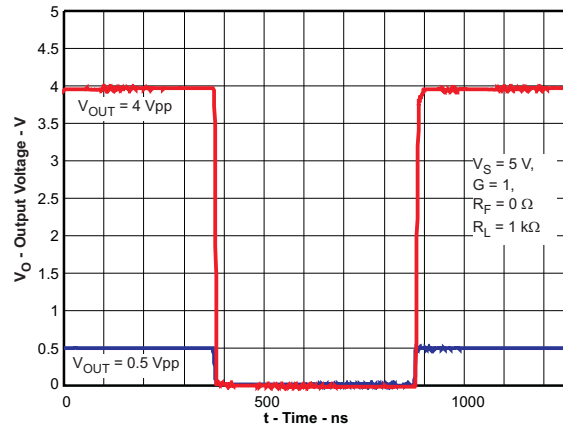

Figure 28. Noninverting Pulse Response

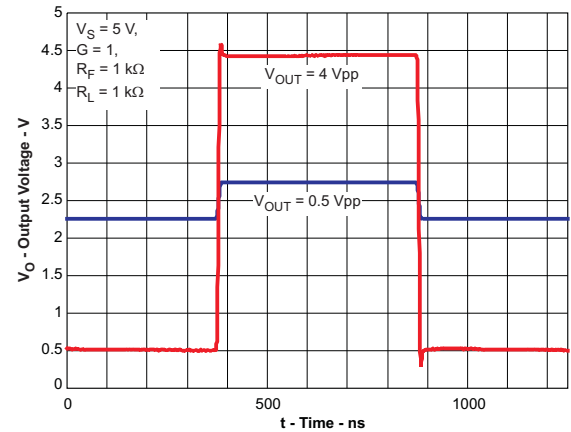

Figure 29. Inverting Pulse Response

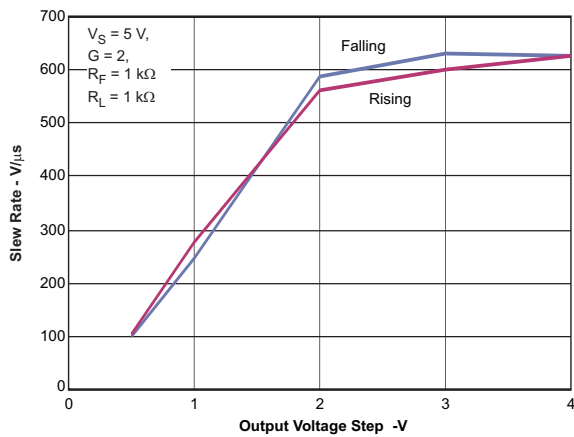

Figure 30. Slew Rate vs Output Voltage Step

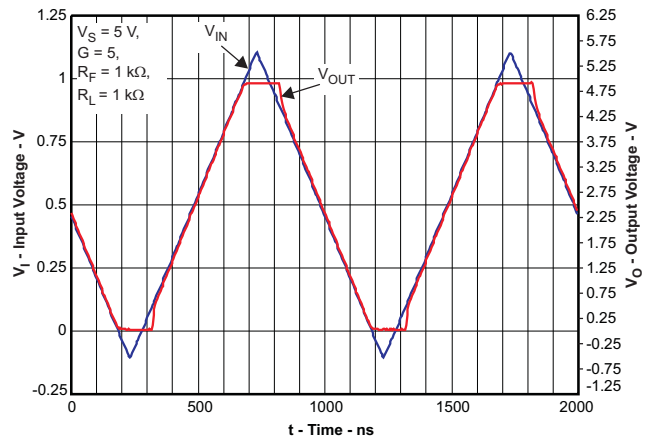

Figure 31. Output Overdrive Recovery



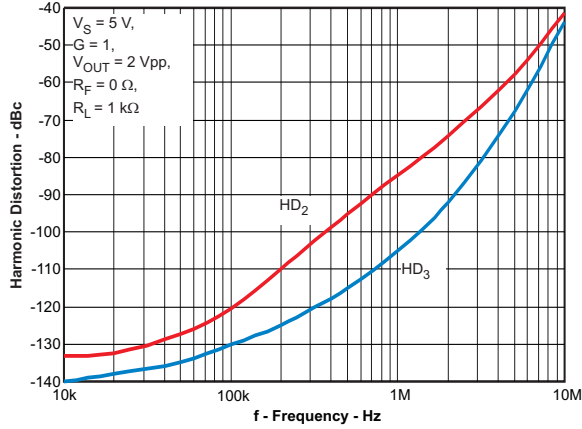

Figure 32. Harmonic Distortion vs Frequency

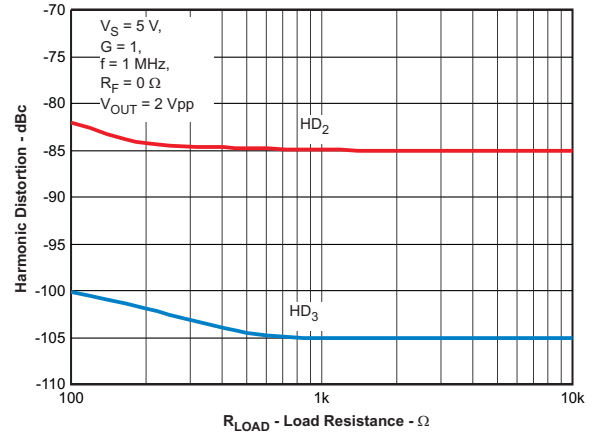

Figure 33. Harmonic Distortion vs Load Resistance

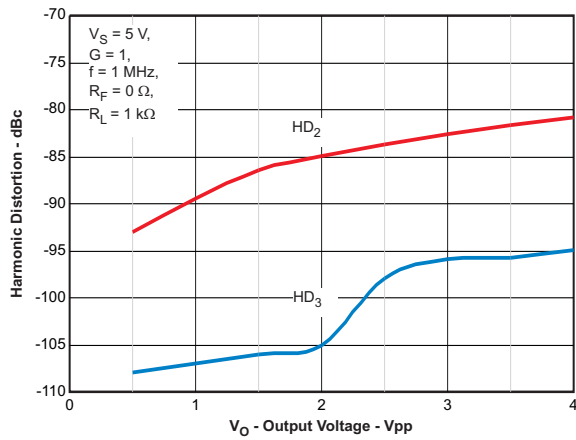

Figure 34. Harmonic Distortion vs Output Voltage

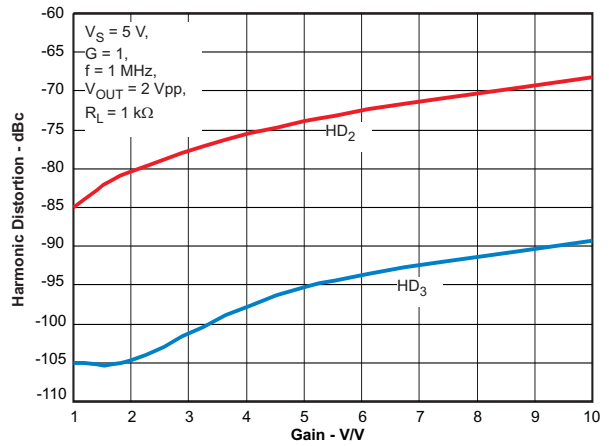

Figure 35. Harmonic Distortion vs Gain

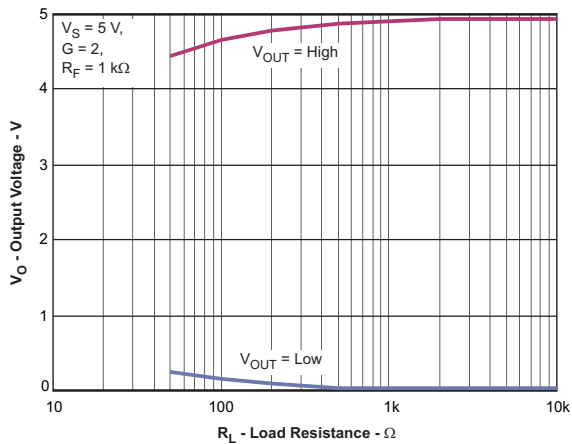

Figure 36. Output Voltage Swing vs Load Resistance

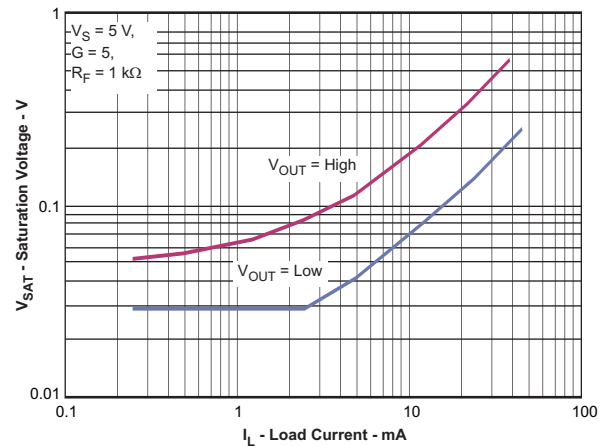

Figure 37. Output Saturation Voltage vs Load Current

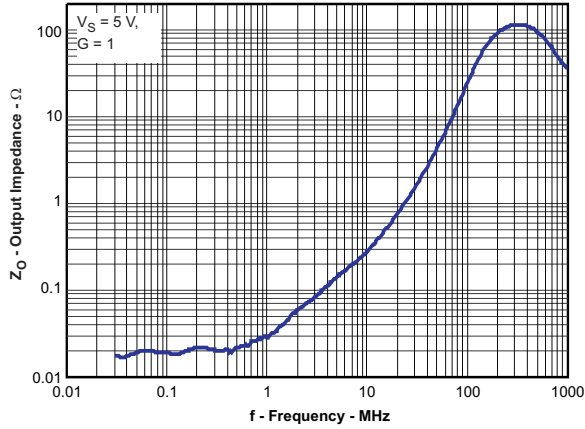

Figure 38. Output Impedance vs Frequency

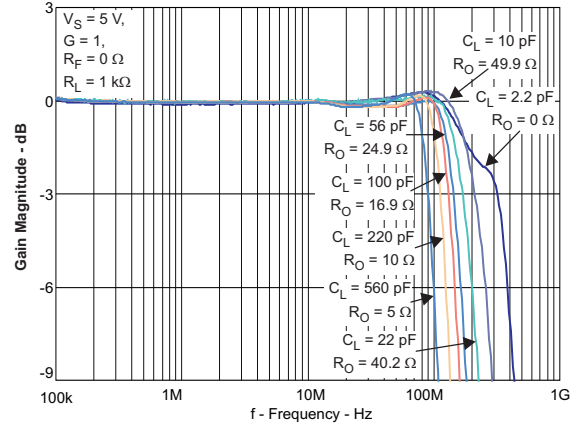

Figure 39. Frequency Response With Capacitive Load

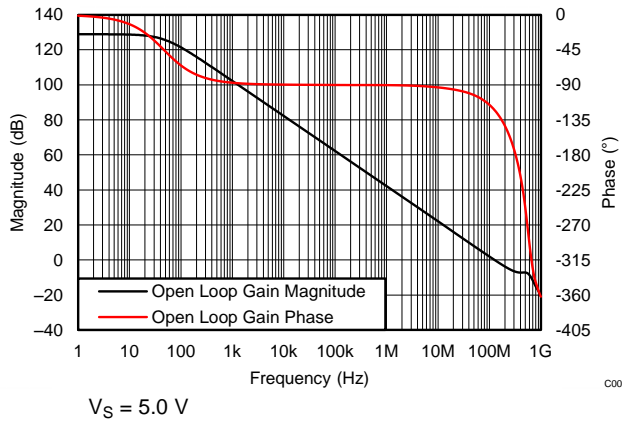

Figure 40. Open-Loop Gain vs Frequency

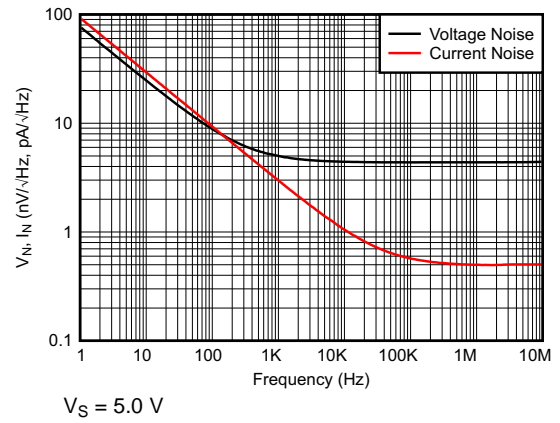

Figure 41. Input-Referred Noise vs Frequency

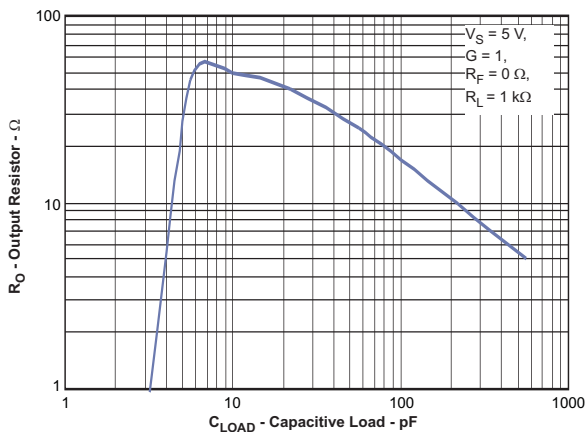

Figure 42. Series Output Resistor vs Capacitive Load

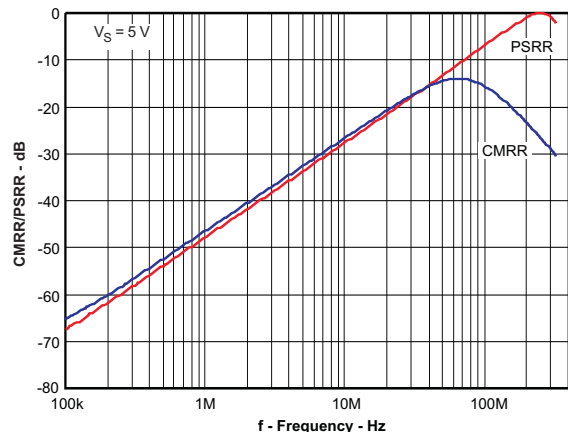

Figure 43. Common-Mode, Power-Supply Rejection Ratios vs Frequency

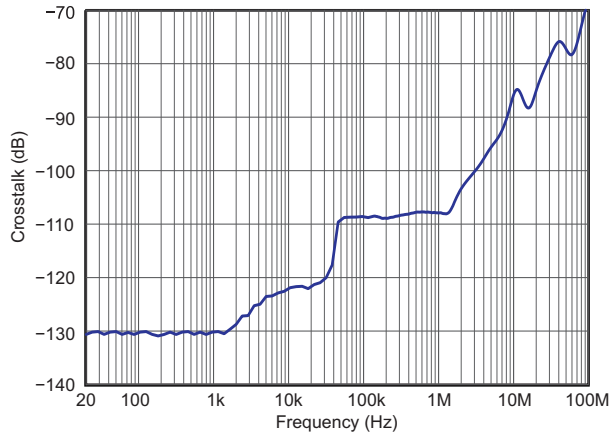

Figure 44. Crosstalk vs Frequency

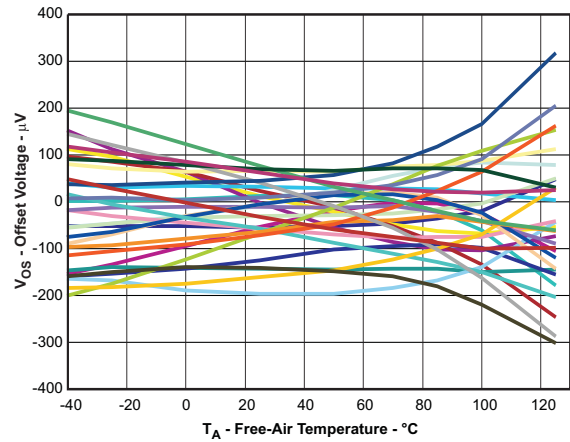

Figure 45. Input Offset Voltage vs Free-Air Temperature

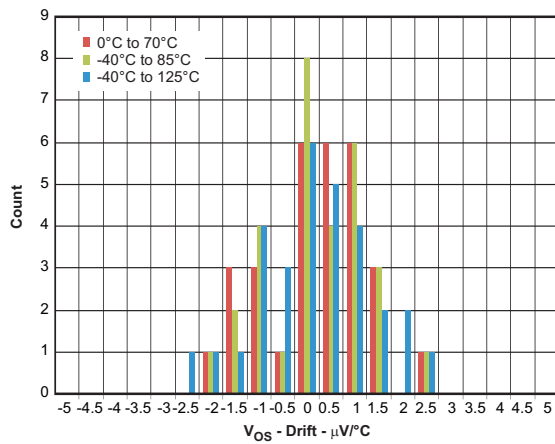

Figure 46. Input Offset Voltage Drift

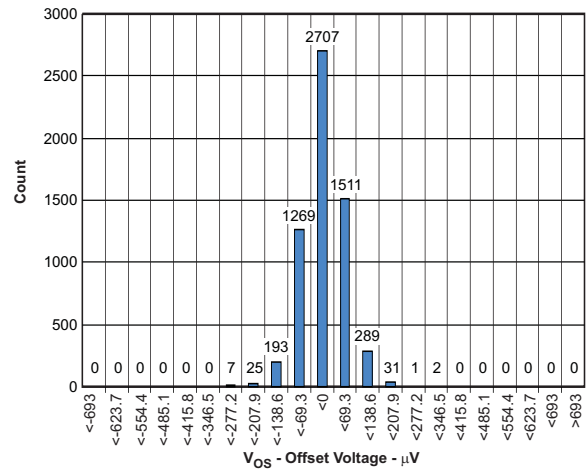

Figure 47. Input Offset Voltage

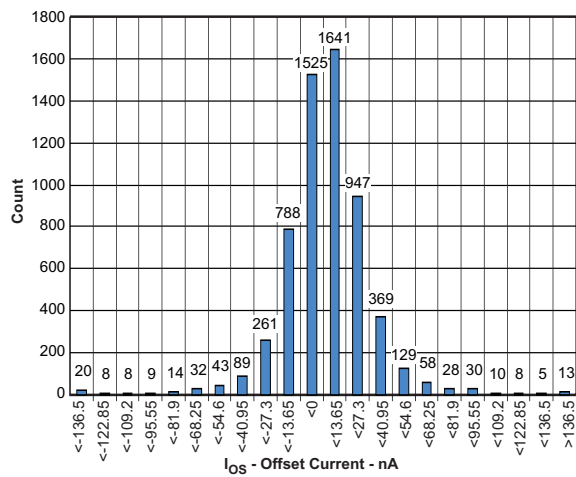

Figure 48. Input Offset Current

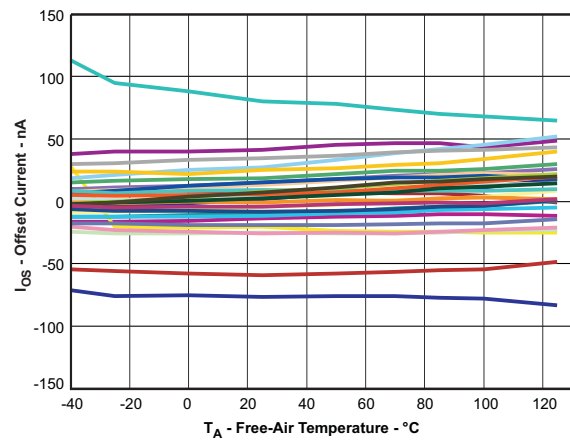
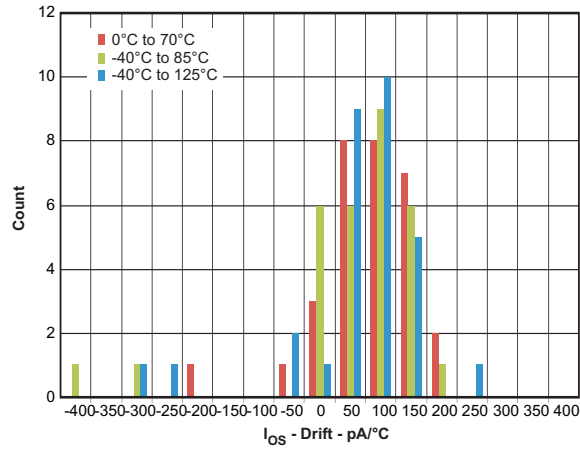

Figure 49. Input Offset Current vs Free-Air Temperature



**Figure 50. Input Offset Current Drift**

## 8 Detailed Description

### 8.1 Overview

The OPA2836-Q1 bipolar input operational amplifier offers an excellent bandwidth of 205 MHz with ultra-low THD of 0.00003% at 1 kHz. The OPA2836-Q1 can swing to within 200 mV of the supply rails when driving a 1-k $\Omega$  load. The input common-mode of the amplifier can swing to 200 mV below the negative supply rail. This level of performance is achieved at 1 mA of quiescent current per amplifier channel.

### 8.2 Functional Block Diagrams

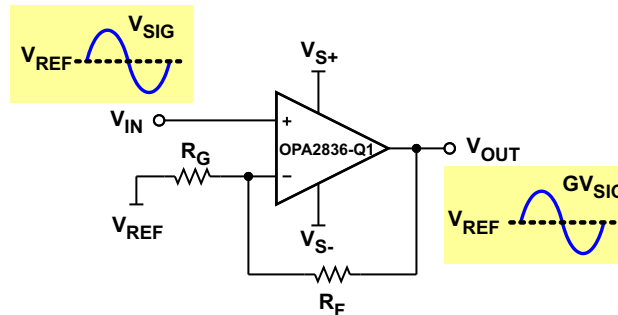

Copyright © 2016, Texas Instruments Incorporated

Figure 51. Noninverting Amplifier

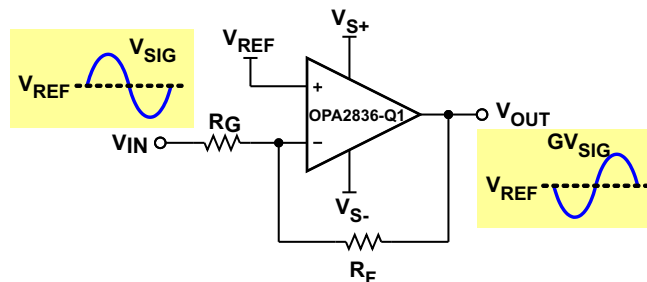

Copyright © 2016, Texas Instruments Incorporated

Figure 52. Inverting Amplifier

### 8.3 Feature Description

#### 8.3.1 Input Common-Mode Voltage Range

When the primary design goal is a linear amplifier with high CMRR, the input common-mode voltage range ( $V_{ICR}$ ) of the amplifier must not be violated.

The common-mode input range low and high specifications are based on CMRR. The specification limits are chosen to ensure CMRR does not degrade more than 3 dB below the mid-supply limit if the input voltage is kept within the specified range. The limits cover all process variations and most parts are better than specified. The typical specifications are from 0.2 V below the negative rail to 1.1 V below the positive rail.

Given that the operational amplifier is in linear operation, the voltage difference between the input pins is very small (ideally 0 V), and input common-mode voltage can be analyzed at either input pin with the other input pin assumed to be at the same potential. The voltage at  $V_{IN+}$  is easy to evaluate. In the noninverting configuration, [Figure 51](#), the input signal  $V_{IN}$  must not violate  $V_{ICR}$ . In the inverting configuration, [Figure 52](#), the reference voltage  $V_{REF}$  must be within  $V_{ICR}$ .

## Feature Description (continued)

The input voltage limits have a fixed headroom to the power rails and track the power-supply voltages. For one 5-V supply, the linear input voltage range is  $-0.2\text{ V}$  to  $3.9\text{ V}$ , and with a 2.7-V supply this range is  $-0.2\text{ V}$  to  $1.6\text{ V}$ . The delta from each power-supply rail is the same in either case:  $-0.2\text{ V}$  and  $1.1\text{ V}$ .

### 8.3.2 Output Voltage Range

The OPA2836-Q1 is a rail-to-rail output (RRO) operational amplifier. Rail-to-rail output typically means the output voltage can swing to within a couple hundred millivolts of the supply rails. There are two different ways to specify this: with the output still in linear operation and with the output saturated. Saturated output voltages are closer to the power-supply rails than linear outputs, but the signal is not a linear representation of the input. Linear output is a better representation of how well a device performs when used as a linear amplifier. Both saturation and linear operation limits are affected by the current in the output, where higher currents lead to more loss in the output transistors.

Data in the [Electrical Characteristics](#) tables list both linear and saturated output voltage specifications with a 1-k $\Omega$  load. [Figure 11](#) and [Figure 36](#) illustrate saturated voltage-swing limits versus output load resistance, and [Figure 12](#) and [Figure 37](#) illustrate the output saturation voltage versus load current. Given a light load, the output voltage limits have a nearly constant headroom to the power rails and track the power-supply voltages. For example, with a 2-k $\Omega$  load and a single 5-V supply, the linear output voltage range is  $0.15\text{ V}$  to  $4.8\text{ V}$ , and with a 2.7-V supply this range is  $0.15\text{ V}$  to  $2.5\text{ V}$ . The delta from each power-supply rail is the same in either case:  $0.15\text{ V}$  and  $0.2\text{ V}$ .

With devices such as the OPA2836-Q1 where the input range is lower than the output range, the input typically limits the available signal swing only in the noninverting gain of 1. Signal swings in noninverting configurations in gains greater than +1 and in inverting configurations in any gain are generally limited by the output voltage limits of the operational amplifier.

### 8.3.3 Low-Power Applications and the Effects of Resistor Values on Bandwidth

The OPA2836-Q1 is designed for the nominal value of  $R_F$  to be 1 k $\Omega$  in gains other than +1 V/V. This value of  $R_F = 1\text{ k}\Omega$  gives excellent distortion performance, maximum bandwidth, best flatness, and best pulse response. This value also loads the amplifier. For example, in a gain of 2 with  $R_F = R_G = 1\text{ k}\Omega$ ,  $R_G$  to ground, and  $V_{OUT} = 4\text{ V}$ , 2 mA of current flows through the feedback path to ground. In a gain of +1,  $R_G$  is open and no current flows to ground. In low-power applications, reducing this current by increasing the gain-setting resistors values is desirable. Using larger value gain resistors has two primary side effects (other than lower power) because of the interaction with parasitic circuit capacitance:

- Lowers the bandwidth
- Lowers the phase margin
  - Causes peaking in the frequency response
  - Also causes overshoot and ringing in the pulse response

## Feature Description (continued)

Figure 53 shows the small-signal frequency response for a noninverting gain of 2 with  $R_F$  and  $R_G$  equal to 1 k $\Omega$ , 10 k $\Omega$ , and 100 k $\Omega$ . The test was done with  $R_L = 1$  k $\Omega$ . Lower values can reduce the peaking because of loading effects of  $R_L$ , but higher values do not have a significant effect.

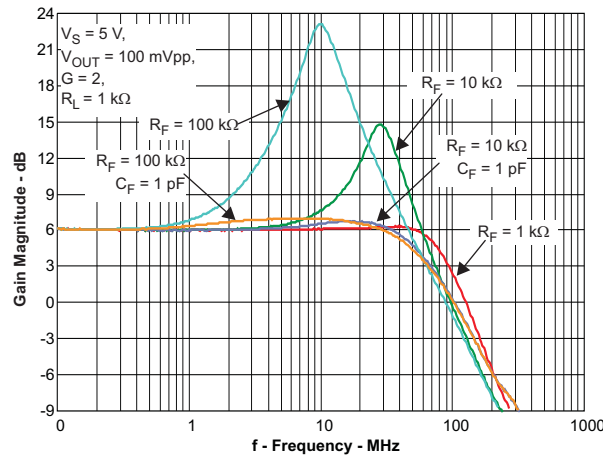
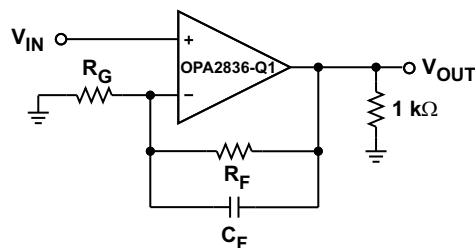

Figure 53. Frequency Response With Various Gain-Setting Resistor Values

As expected, larger value gain resistors cause lower bandwidth and peaking in the response (peaking in the frequency response is synonymous with overshoot and ringing in pulse response). Adding 1-pF capacitors in parallel with  $R_F$  helps compensate the phase margin and restores flat frequency response. Figure 54 shows the test circuit used.



Copyright © 2016, Texas Instruments Incorporated

Figure 54.  $G = 2$  Test Circuit for Various Gain-Setting Resistor Values

### 8.3.4 Driving Capacitive Loads

The OPA2836-Q1 can drive up to a nominal capacitive load of 2.2 pF on the output with no special consideration. When driving capacitive loads greater than this load, using a small resistor ( $R_O$ ) in series with the output as close to the device as possible is recommended. Without  $R_O$ , the capacitance on the output interacts with the output impedance of the amplifier causing phase shift in the loop gain of the amplifier that reduces the phase margin. This scenario causes peaking in the frequency response and overshoot and ringing in the pulse responses. Interaction with other parasitic elements can lead to instability or oscillation. Inserting  $R_O$  isolates the phase shift from the loop-gain path and restores the phase margin; however, the bandwidth is also limited.

## Feature Description (continued)

Figure 55 shows the test circuit and Figure 42 illustrates the recommended values of  $R_O$  versus capacitive loads,  $C_L$ . See Figure 39 for frequency responses with various values.

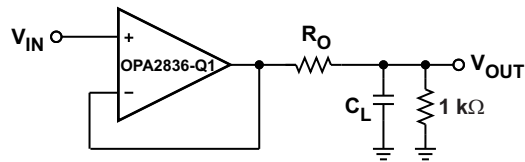

Copyright © 2016, Texas Instruments Incorporated

Figure 55.  $R_O$  versus  $C_L$  Test Circuit

## 8.4 Device Functional Modes

### 8.4.1 Split-Supply Operation ( $\pm 1.25$ V to $\pm 2.75$ V)

To facilitate testing with common lab equipment, the OPA2836-Q1 EVM (see the *OPA835DBV*, *OPA836DBV* EVM, [SLOU314](#)) is built to allow for split-supply operation. This configuration eases lab testing because the mid-point between the power rails is ground, and most signal generators, network analyzers, oscilloscopes, spectrum analyzers, and other lab equipment reference inputs and outputs to ground.

Figure 56 shows a simple noninverting configuration analogous to Figure 51 with a  $\pm 2.5$ -V supply and  $V_{REF}$  equal to ground. The input and output swing symmetrically around ground. Split-supply operation is preferred because of the ease of use in systems where signals swing around ground, but two supply rails still must be generated.

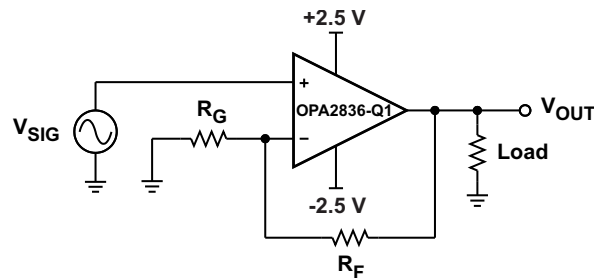

Copyright © 2016, Texas Instruments Incorporated

Figure 56. Split-Supply Operation



## Device Functional Modes (continued)

### 8.4.2 Single-Supply Operation (2.5 V to 5.5 V)

Many newer systems use a single power supply to improve efficiency and reduce the cost of the power supply. The OPA2836-Q1 is designed for use with single-supply power operation and can be used with single-supply power with no change in performance from split supply as long as the input and output are biased within the linear operation of the device.

To change the circuit from split supply to single supply, level shift all voltages by half the difference between the power-supply rails. For example, changing from a  $\pm 2.5\text{-V}$  split supply to a 5-V single supply is shown conceptually in Figure 57.

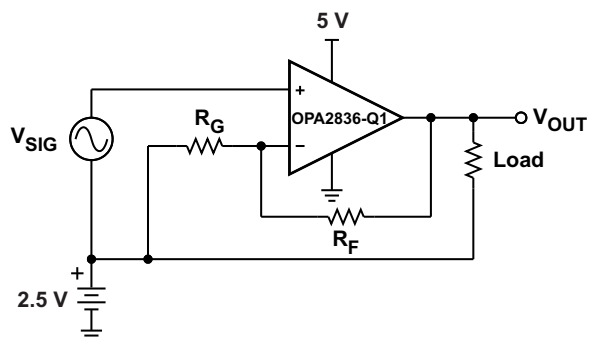

Copyright © 2016, Texas Instruments Incorporated

Figure 57. Single Supply Concept

A more practical circuit has a prior amplifier or another circuit to provide the bias voltage for the input with the output providing the bias for the next stage.

Figure 58 shows a typical noninverting amplifier situation. With a 5-V single supply, a mid-supply reference generator is needed to bias the negative side through  $R_G$ . To cancel the voltage offset that is otherwise caused by the input bias currents,  $R_1$  is chosen to be equal to  $R_F$  in parallel with  $R_G$ . For example, if a gain of 2 is required and  $R_F = 1\text{ k}\Omega$ , select  $R_G = 1\text{ k}\Omega$  to set the gain and  $R_1 = 499\ \Omega$  for bias current cancellation. The value for  $C$  is dependent on the reference, but at least  $0.1\ \mu\text{F}$  is recommended to limit noise.

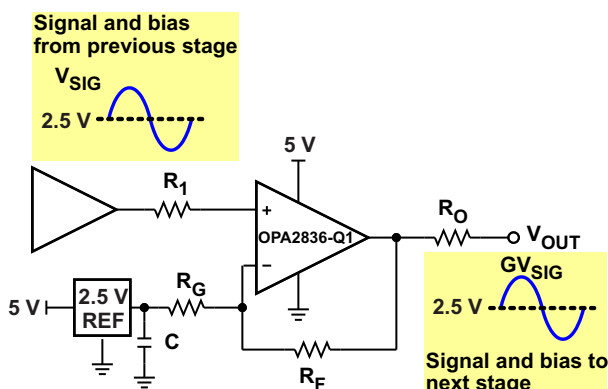

Copyright © 2016, Texas Instruments Incorporated

Figure 58. Noninverting Single Supply With Reference

## Device Functional Modes (continued)

Figure 59 shows a similar noninverting single-supply scenario with the reference generator replaced by the Thevenin equivalent using resistors and the positive supply.  $R_G'$  and  $R_G''$  form a resistor divider from the 5-V supply and are used to bias the negative side with the parallel sum equal to the equivalent  $R_G$  to set the gain. To cancel the voltage offset that is otherwise caused by the input bias currents,  $R_1$  is chosen to be equal to  $R_F$  in parallel with  $R_G$  in parallel with  $R_G''$  ( $R_1 = R_F \parallel R_G' \parallel R_G''$ ). For example, if a gain of 2 is required and  $R_F = 1\text{ k}\Omega$ , selecting  $R_G' = R_G'' = 2\text{ k}\Omega$  gives an equivalent parallel sum of  $1\text{ k}\Omega$ , sets the gain to 2, and references the input to mid supply (2.5 V).  $R_1$  is then set to  $499\ \Omega$  for bias current cancellation, which can be lower cost compared to Figure 59 but requires extra current in the resistor divider.

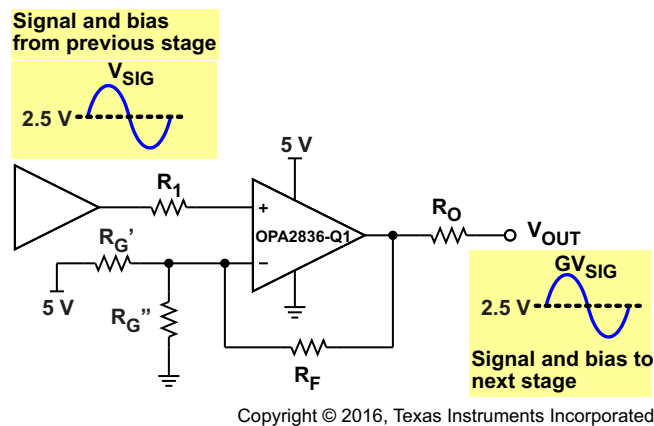

**Figure 59. Noninverting Single Supply With Resistors**

Figure 60 shows a typical inverting amplifier situation. With a 5-V single supply, a mid-supply reference generator is needed to bias the positive side via  $R_1$ . To cancel the voltage offset that is otherwise caused by the input bias currents,  $R_1$  is chosen to be equal to  $R_F$  in parallel with  $R_G$ . For example, if a gain of  $-2$  is required and  $R_F = 1\text{ k}\Omega$ , select  $R_G = 499\ \Omega$  to set the gain and  $R_1 = 332\ \Omega$  for bias-current cancellation. The value for  $C$  is dependent on the reference, but at least  $0.1\ \mu\text{F}$  is recommended to limit noise into the operational amplifier.

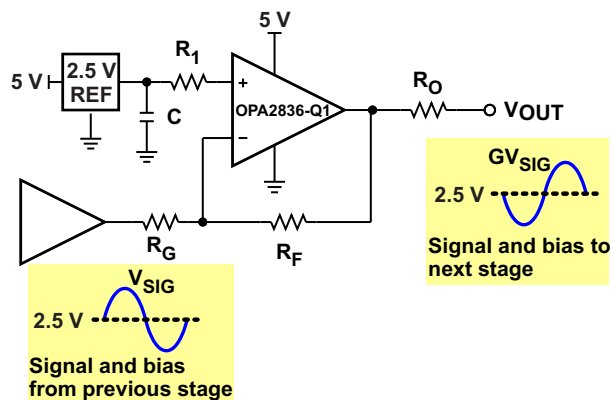

**Figure 60. Inverting Single Supply With Reference**

## Device Functional Modes (continued)

Figure 61 shows a similar inverting single-supply scenario with the reference generator replaced by the Thevenin equivalent using resistors and the positive supply.  $R_1$  and  $R_2$  form a resistor divider from the 5-V supply and are used to bias the positive side. To cancel the voltage offset that is otherwise caused by the input bias currents, set the parallel sum of  $R_1$  and  $R_2$  equal to the parallel sum of  $R_F$  and  $R_G$ .  $C$  must be added to limit coupling of noise into the positive input. For example, if a gain of  $-2$  is required and  $R_F = 1\text{ k}\Omega$ , select  $R_G = 499\ \Omega$  to set the gain.  $R_1 = R_2 = 665\ \Omega$  for mid-supply voltage bias and for operational amplifier input bias current cancellation. A good value for  $C$  is  $0.1\ \mu\text{F}$  and can be a lower cost compared to Figure 61, but requires extra current in the resistor divider.

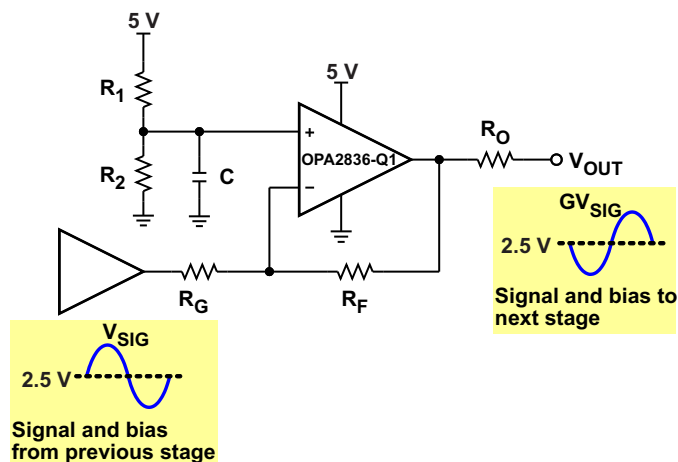

Copyright © 2016, Texas Instruments Incorporated

Figure 61. Inverting Single Supply With Resistors

## 9 Application and Implementation

### NOTE

Information in the following applications sections is not part of the TI component specification, and TI does not warrant its accuracy or completeness. TI's customers are responsible for determining suitability of components for their purposes. Customers should validate and test their design implementation to confirm system functionality.

### 9.1 Application Information

#### 9.1.1 Noninverting Amplifier

The OPA2836-Q1 can be used as a noninverting amplifier with a signal input to the noninverting input,  $V_{IN+}$ . A basic block diagram of the circuit is illustrated in [Figure 51](#).

If  $V_{IN} = V_{REF} + V_{SIG}$ , then the output of the amplifier can be calculated according to [Equation 1](#).

$$V_{OUT} = V_{SIG} \left( 1 + \frac{R_F}{R_G} \right) + V_{REF} \quad (1)$$

$$G = 1 + \frac{R_F}{R_G}$$

The signal gain of the circuit is set by  $\frac{R_F}{R_G}$ , and  $V_{REF}$  provides a reference around which the input and output signals swing. Output signals are in-phase with the input signals.

The OPA2836-Q1 is designed for the nominal value of  $R_F$  to be 1 k $\Omega$  in gains other than +1. This value gives excellent distortion performance, maximum bandwidth, best flatness, and best pulse response.  $R_F = 1$  k $\Omega$  must be used as a default unless other design goals require changing to other values. All test circuits used to collect data for this document have  $R_F = 1$  k $\Omega$  for all gains other than +1. Gain of +1 is a special case where  $R_F$  is shorted and  $R_G$  is left open.

#### 9.1.2 Inverting Amplifier

The OPA2836-Q1 can be used as an inverting amplifier with a signal input to the inverting input,  $V_{IN-}$ , through the gain setting resistor  $R_G$ . A basic block diagram of the circuit is illustrated in [Figure 52](#).

If  $V_{IN} = V_{REF} + V_{SIG}$ , then the output of the amplifier may be calculated according to [Equation 2](#).

$$V_{OUT} = V_{SIG} \left( \frac{-R_F}{R_G} \right) + V_{REF} \quad (2)$$

$$G = \frac{-R_F}{R_G}$$

The signal gain of the circuit is set by:  $\frac{-R_F}{R_G}$ , and  $V_{REF}$  provides a reference point around which the input and output signals swing. Output signals are 180° out-of-phase with the input signals. The nominal value of  $R_F$  must be 1 k $\Omega$  for inverting gains.

#### 9.1.3 Instrumentation Amplifier

[Figure 62](#) is an instrumentation amplifier that combines the high input impedance of the differential-to-differential amplifier circuit and the common-mode rejection of the differential-to-single-ended amplifier circuit. This circuit is often used in applications where high input impedance is required (such as taps from a differential line or in cases where the signal source has a high output impedance).

If  $V_{IN+} = V_{CM} + V_{SIG+}$  and  $V_{IN-} = V_{CM} + V_{SIG-}$ , then the output of the amplifier can be calculated according to [Equation 3](#).

$$V_{OUT} = (V_{IN+} - V_{IN-}) \times \left( 1 + \frac{2R_{F1}}{R_{G1}} \right) \left( \frac{R_{F2}}{R_{G2}} \right) + V_{REF} \quad (3)$$

## Application Information (continued)

$$G = \left( 1 + \frac{2R_{F1}}{R_{G1}} \right) \left( \frac{R_{F2}}{R_{G2}} \right)$$

The signal gain of the circuit is set by  $V_{CM}$  is rejected and  $V_{REF}$  provides a level shift around which the output signal swings. The single-ended output signal is in-phase with the differential input signal.

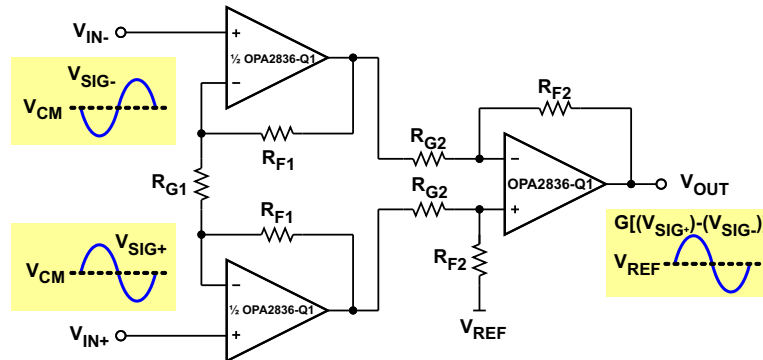

Figure 62. Instrumentation Amplifier

Integrated solutions are available, but the OPA2836-Q1 provides a much lower-power, high-frequency solution. For best CMRR performance, resistors must be matched. Given that  $CMRR \approx$  the resistor tolerance, a 0.1% tolerance provides approximately 60-dB CMRR.

### 9.1.4 Attenuators

The noninverting circuit of Figure 51 has a minimum gain of 1. To implement attenuation, a resistor divider can be placed in series with the positive input, and the amplifier can be set for a gain of 1 by shorting  $V_{OUT}$  to  $V_{IN-}$  and removing  $R_G$ . Because the operational amplifier input has high input impedance, the attenuation is set by the resistor divider.

The inverting circuit of Figure 52 can be used as an attenuator by making  $R_G$  larger than  $R_F$ . The attenuation is simply the resistor ratio. For example, a 10:1 attenuator can be implemented with  $R_F = 1 \text{ k}\Omega$  and  $R_G = 10 \text{ k}\Omega$ .

### 9.1.5 Single-Ended-to-Differential Amplifier

Figure 63 illustrates an amplifier circuit that is used to convert single-ended signals to differential and that provides gain and level shifting. This circuit can be used for converting signals to differential in applications (such as line drivers for Cat5 cabling or for driving differential-input SAR and  $\Delta\Sigma$  ADCs).

With  $V_{IN} = V_{REF} + V_{SIG}$ , the output of the amplifier can be calculated according to Equation 4.

$$V_{OUT+} = G \times V_{IN} + V_{REF} \quad \text{and} \quad V_{OUT-} = -G \times V_{IN} + V_{REF} \quad \text{Where: } G = 1 + \frac{R_F}{R_G} \quad (4)$$

The differential-signal gain of the circuit is  $2 \times G$ , and  $V_{REF}$  provides a reference around which the output signal swings. The differential output signal is in-phase with the single-ended input signal.

**Application Information (continued)**

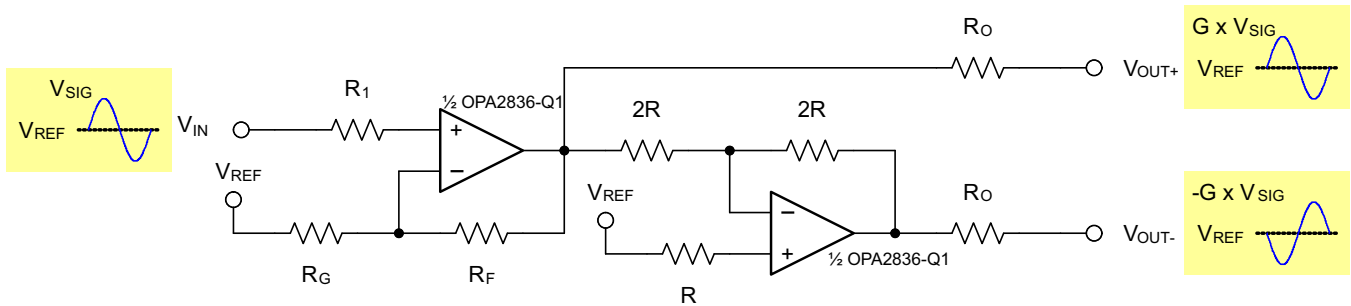

Copyright © 2016, Texas Instruments Incorporated

**Figure 63. Single-Ended-to-Differential Amplifier**

Line termination on the output can be accomplished with resistors  $R_O$ . The differential input impedance of the circuit is  $2 \times R_O$ . For example, if a 100- $\Omega$  Cat5 cable is used with double termination, the amplifier is typically set for a differential gain of 2 V/V (6 dB) with  $R_F = 0 \Omega$  (short),  $R_G = \text{open}$ ,  $2R = 1 \text{ k}\Omega$ ,  $R_1 = 0 \Omega$ ,  $R = 499 \Omega$  to balance the input bias currents, and  $R_O = 49.9 \Omega$  for output line termination. This configuration is shown in Figure 64.

For driving a differential-input ADC, the situation is similar but the output resistors ( $R_O$ ) are typically chosen along with a capacitor across the ADC input for optimum filtering and settling-time performance.

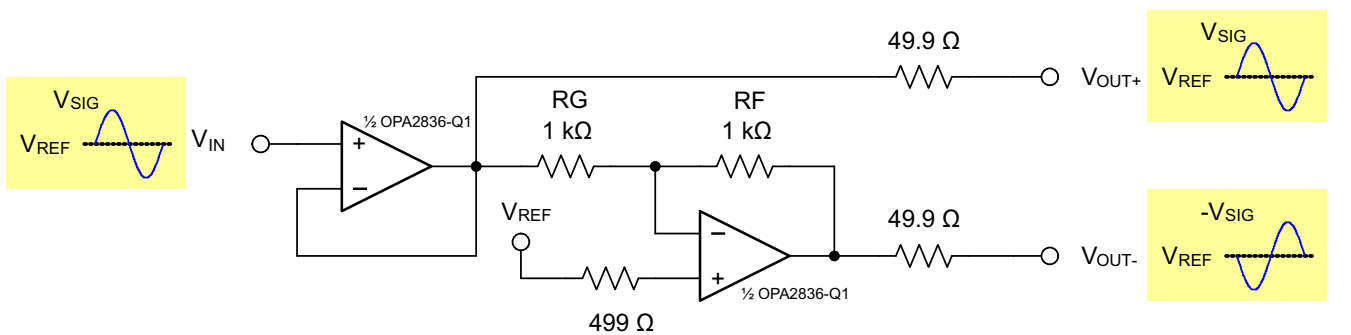

Copyright © 2016, Texas Instruments Incorporated

**Figure 64. Cat5 Line Driver With Gain = 2 V/V (6 dB)**

**9.1.6 Differential-to-Signal-Ended Amplifier**

Figure 65 illustrates a differential amplifier that converts differential signals to single-ended and provides gain (or attenuation) and level shifting. This circuit can be used in applications such as a line receiver for converting a differential signal from a Cat5 cable to single ended.

If  $V_{IN+} = V_{CM} + V_{SIG+}$  and  $V_{IN-} = V_{CM} + V_{SIG-}$ , then the output of the amplifier can be calculated according to Equation 5.

$$V_{OUT} = (V_{IN+} - V_{IN-}) \times \left( \frac{R_F}{R_G} \right) + V_{REF} \tag{5}$$

The signal gain of the circuit is set by  $G = \frac{R_F}{R_G}$ .  $V_{CM}$  is rejected, and  $V_{REF}$  provides a level shift around which the output signal swings. The single-ended output signal is in-phase with the differential input signal.

Application Information (continued)

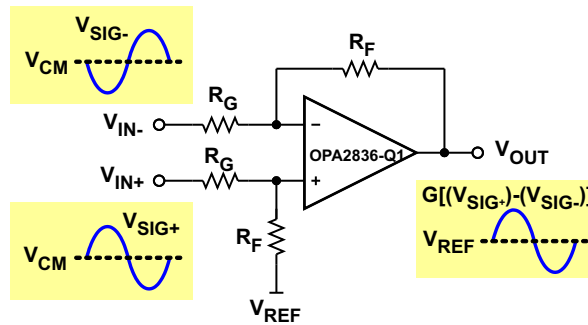

Copyright © 2016, Texas Instruments Incorporated

Figure 65. Differential to Single Ended Amplifier

Line termination can be accomplished with a resistor shunt across the input. The differential input impedance of the circuit is the resistor value in parallel with the amplifier circuit. For low-gain and low-line impedance, the resistor value to add is approximately the impedance of the line. For example, if a 100-Ω Cat5 cable is used with a gain of 1 amplifier and  $R_F = R_G = 1\text{ k}\Omega$ , adding a 100-Ω shunt across the input gives a differential impedance of 98 Ω that is adequate for most applications.

For best CMRR performance, resistors must be matched. A rule of thumb is  $\text{CMRR} \approx$  the resistor tolerance; so a 0.1% tolerance provides approximately 60-dB CMRR.

9.1.7 Differential-to-Differential Amplifier

Figure 66 shows a differential amplifier that is used to amplify differential signals. This circuit has high input impedance and is often used in differential line driver applications where the signal source is a high-impedance driver (for example, a differential DAC) that must drive a line.

If  $V_{IN\pm} = V_{CM} + V_{SIG\pm}$ , then the output of the amplifier can be calculated according to Equation 6.

$$V_{OUT\pm} = V_{IN\pm} \times \left( 1 + \frac{2R_F}{R_G} \right) + V_{CM} \tag{6}$$

$$G = 1 + \frac{2R_F}{R_G}$$

The signal gain of the circuit is set by  $G = 1 + \frac{2R_F}{R_G}$ , and  $V_{CM}$  passes with unity gain. The amplifier in essence combines two noninverting amplifiers into one differential amplifier with the  $R_G$  resistor shared, which makes  $R_G$  effectively half the value when calculating the gain. The output signals are in-phase with the input signals.

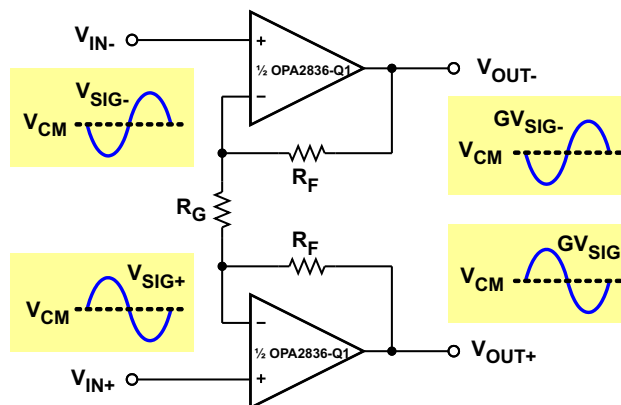

Copyright © 2016, Texas Instruments Incorporated

Figure 66. Differential to Differential Amplifier

## Application Information (continued)

### 9.1.8 Pulse Application With Single-Supply

For pulsed applications, where the signal is at ground and pulses to some positive or negative voltage, the circuit bias-voltage considerations are different than with a signal that swings symmetrical about a reference point. [Figure 67](#) shows a pulsed situation where the signal is at ground (0 V) and pulses to a positive value.

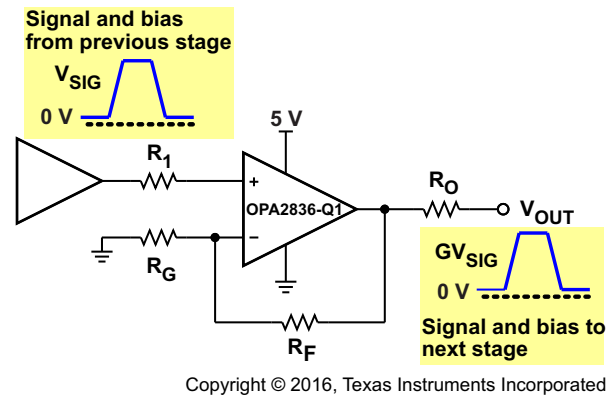

**Figure 67. Noninverting Single Supply With Pulse**

If the input signal pulses negatively from ground, an inverting amplifier is more appropriate, as shown in [Figure 68](#). A key consideration in both noninverting and inverting cases is that the input and output voltages are kept within the limits of the amplifier; because the  $V_{ICR}$  of the OPA2836-Q1 includes the negative supply rail, the OPA2836-Q1 lends itself to this application.

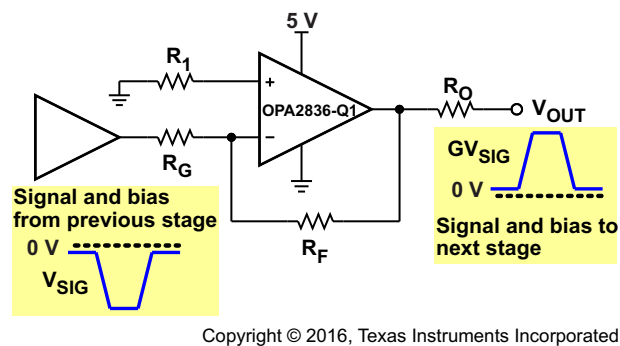

**Figure 68. Inverting Single Supply With Pulse**

### 9.1.9 ADC Driver Performance

The OPA2836-Q1 provides excellent performance when driving high-performance, delta-sigma ( $\Delta\Sigma$ ), and successive approximation register (SAR) ADCs in low-power audio and industrial applications.

To show achievable performance, the OPA2836-Q1 is tested as the drive amplifier for the [ADS8326](#). The ADS8326 is a 16-bit, micro power, SAR ADC with pseudo-differential inputs and sample rates up to 250 kSPS. The ADS8326 offers excellent noise and distortion performance in a small 8-pin SOIC or VSSOP (MSOP) package. Low power and small size make the ADS8326 and OPA2836-Q1 devices an ideal solution for portable and battery-operated systems, for remote data-acquisition modules, simultaneous multichannel systems, and isolated data acquisition.



### Application Information (continued)

The circuit shown in Figure 69 is used to test the performance. Figure 70 is the FFT plot showing the spectral performance with a 10-kHz input frequency, and Table 3 shows the tabulated ac analysis results.

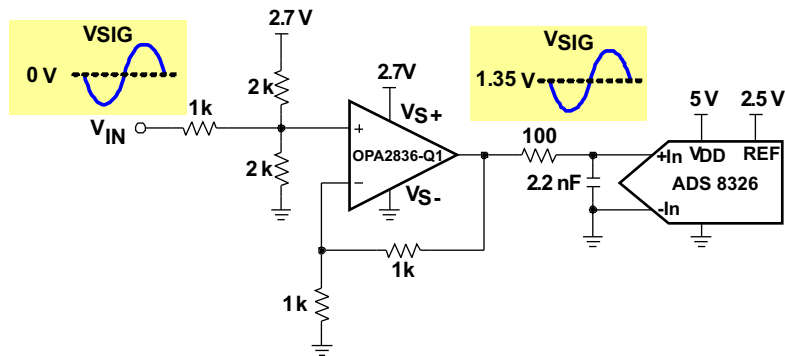

Copyright © 2016, Texas Instruments Incorporated

Figure 69. OPA2836-Q1 and ADS8326 Test Circuit

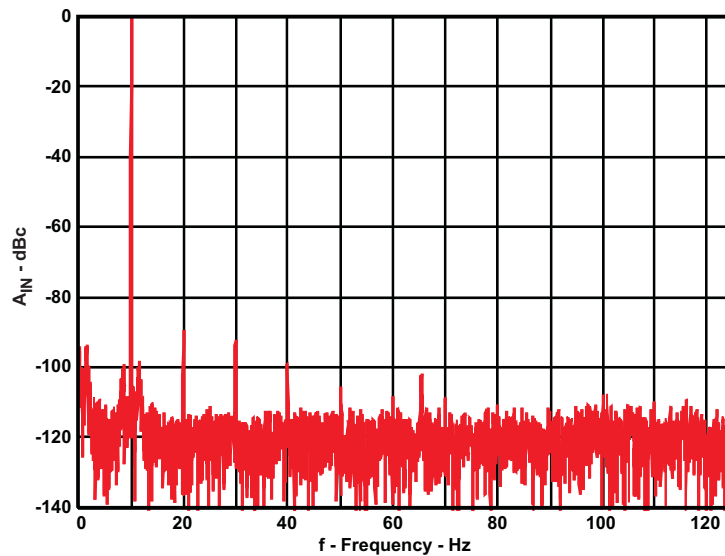

Figure 70. ADS8326 and OPA2836-Q1 10-kHz FFT

Table 3. AC Analysis

| TONE (kHz) | SIGNAL (dBFS) | SNR (dBc) | THD (dBc) | SINAD (dBc) | SFDR (dBc) |
|------------|---------------|-----------|-----------|-------------|------------|
| 10         | -0.85         | 83.3      | -86.6     | 81.65       | 88.9       |

## 9.2 Typical Applications

### 9.2.1 Audio-Frequency Performance

The OPA2836-Q1 provides excellent audio performance with very low quiescent power. To show performance in the audio band, a 2700 series audio analyzer from Audio Precision is used to test THD+N and FFT at  $1\text{-}V_{\text{RMS}}$  output voltage.

Figure 71 shows the test circuit used for the audio-frequency performance application.

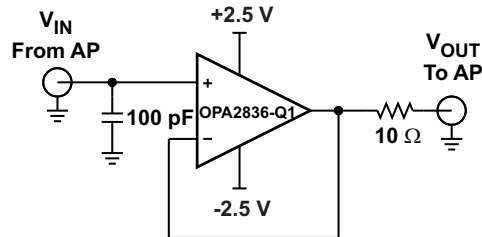

Copyright © 2016, Texas Instruments Incorporated

The 100-pF capacitor to ground on the input helped to decouple noise pick up in the lab and improved noise performance.

**Figure 71. OPA2836-Q1 Audio Precision Analyzer Test Circuit**

#### 9.2.1.1 Design Requirements

Design a low distortion, single-ended input to single-ended output audio amplifier using the OPA2836-Q1. The 2700 series audio analyzer from Audio Precision is used as the signal source and also as the measurement system.

**Table 4. Design Requirements**

| CONFIGURATION                       | INPUT EXCITATION     | PERFORMANCE TARGET | $R_{\text{Load}}$                  |
|-------------------------------------|----------------------|--------------------|------------------------------------|
| OPA2836-Q1 unity-gain configuration | 1-kHz tone frequency | > 110 dBc SFDR     | 300 $\Omega$ and<br>100 k $\Omega$ |

#### 9.2.1.2 Detailed Design Procedure

The OPA2836-Q1 is tested in this application in a unity-gain buffer configuration. A buffer configuration is chosen because this configuration maximizes the loop gain of the amplifier configuration. At higher closed-loop gains, the loop gain of the circuit reduces, resulting in degraded harmonic distortion. The relationship between distortion and closed-loop gain at a fixed input frequency is illustrated in Figure 35 in the *Typical Characteristics* section. The test was performed under varying output load conditions using a resistive load of 300  $\Omega$  and 100 k $\Omega$ . Figure 33 illustrates the distortion performance of the amplifier versus output resistive load. Output loading, output swing, and closed-loop gain play a key role in determining the distortion performance of the amplifier.

#### NOTE

The 100-pF capacitor to ground on the input helped to decouple noise pickup in the lab and improved noise performance.

The Audio Precision was configured as a single-ended output in this application circuit. In applications where a differential output is available, the OPA2836-Q1 device can be configured as a differential-to-single-ended amplifier; see Figure 65. Power-supply bypassing is critical in order to reject noise from the power supplies. A 2.2- $\mu\text{F}$  power-supply decoupling capacitor must be placed within 2 inches of the device and can be shared with other operational amplifiers on the same board. A 0.1- $\mu\text{F}$  power supply decoupling capacitor must be placed as close to the power supply pins as possible, preferably within 0.1 inch. For split supply, a capacitor is required for both supplies. A 0.1- $\mu\text{F}$  capacitor placed directly between the supplies is also beneficial for improving system noise performance. If the output load is very heavy, in the order of 16  $\Omega$  to 32  $\Omega$ , performance of the amplifier can begin to degrade. In order to drive such heavy loads, both channels of the OPA2836-Q1 device can be paralleled with the outputs isolated with 1- $\Omega$  resistors to reduce the loading effects.

### 9.2.1.3 Application Curves

A 10-Ω series resistor can be inserted between the capacitor and the noninverting pin to isolate the capacitance.

Figure 72 shows the THD+N performance with 100-kΩ and 300-Ω loads, with A-weighting and with no weighting. Both loads show similar performance. With no weighting, the THD+N performance is dominated by the noise; whereas, A-weighting provides filtering that improves the noise.

Figure 73 and Figure 74 show FFT outputs with a 1-kHz tone and 100-kΩ and 300-Ω loads. To show relative performance of the device versus the test set, one channel has the OPA2836-Q1 in-line between generator output and analyzer input and the other channel is in Gen Mon loopback mode that internally connects the signal generator to the analyzer input. With a 100-kΩ load, Figure 73, the curves are basically indistinguishable from each other except for noise, meaning that the OPA2836-Q1 cannot be directly measured. With a 300-Ω load, Figure 74, the main difference between the curves is that the OPA2836-Q1 shows slightly higher even-order harmonics, but odd-order harmonics are masked by the test-set performance.

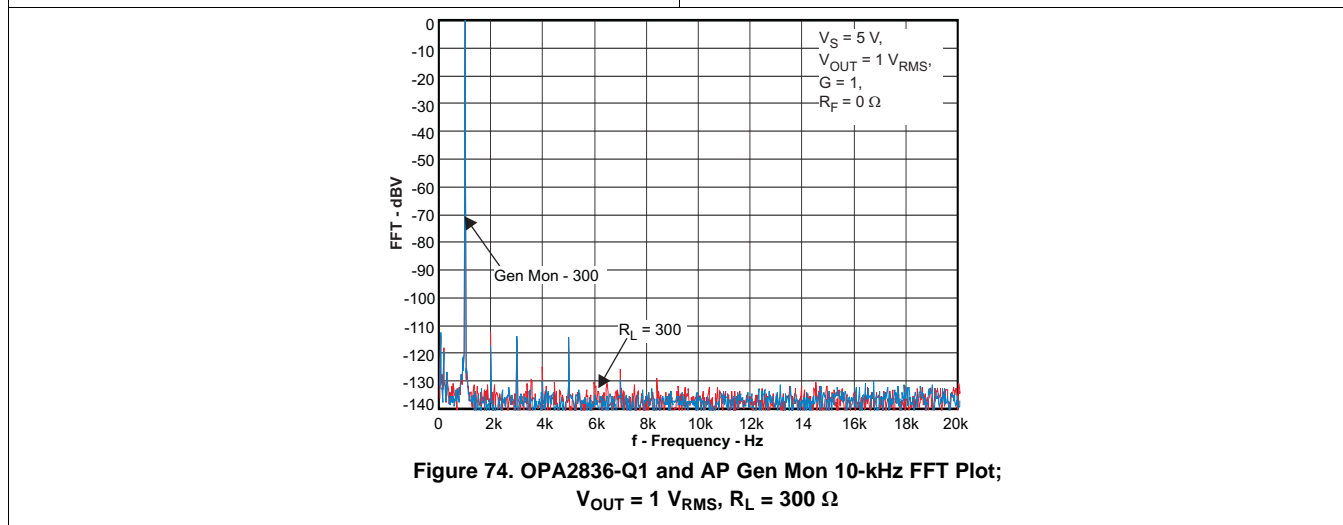
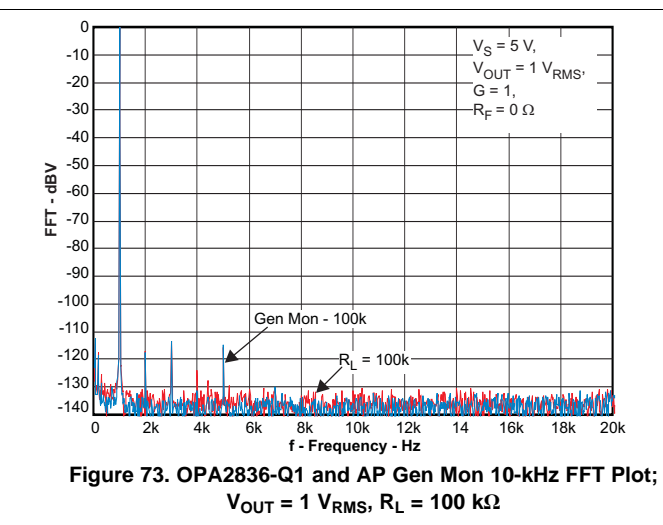
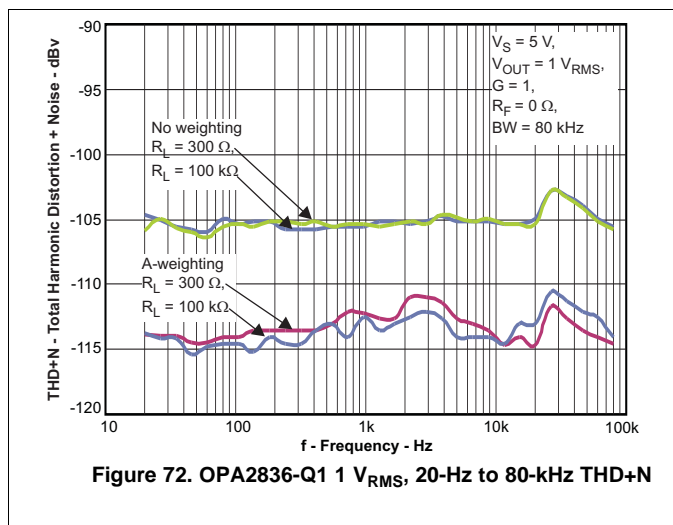

### 9.2.2 Active Filters

The OPA2836-Q1 can be used to design active filters. Figure 75 and Figure 76 show MFB and Sallen-Key circuits designed using the WEBENCH® filter designer to implement second-order low-pass Butterworth filter circuits. Figure 77 shows the frequency response.

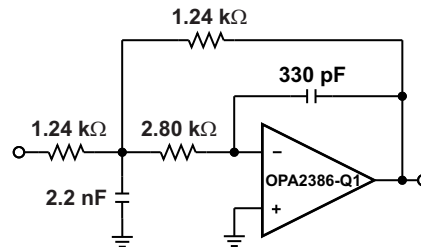

Copyright © 2016, Texas Instruments Incorporated

Figure 75. MFB 100-kHz Second Order Low-Pass Butterworth Filter Circuit

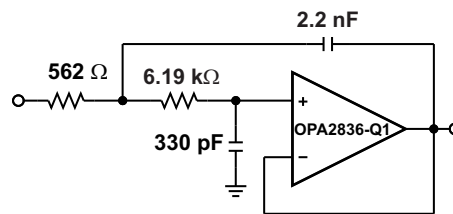

Copyright © 2016, Texas Instruments Incorporated

Figure 76. Sallen-Key 100-kHz Second Order Low-Pass Butterworth Filter Circuit

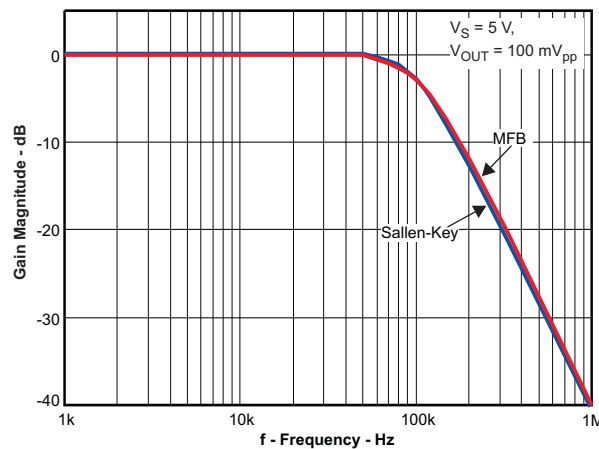

Figure 77. MFB and Sallen-Key Second Order Low-Pass Butterworth Filter Response

MFB and Sallen-Key filter circuits offer similar performance. The main difference is the MFB uses an inverting amplifier in the pass-band and the Sallen-Key uses a noninverting amplifier. The primary advantage for each is the Sallen-Key in unity gain has no resistor gain-error term, and thus no sensitivity to gain error, whereas the MFB has inherently better attenuation properties beyond the bandwidth of the operational amplifier.

## 10 Power Supply Recommendations

The OPA2836-Q1 is principally intended to work in a supply range of 2.7 V to 5 V. Supply voltage tolerances are supported with the specified operating range of 2.5 V (7% on a 2.7-V supply) and 5.5 V (10% on a 5-V supply). Good power-supply bypassing is required. Minimize the distance (< 0.1 inch) from the power-supply pins to high-frequency, 0.1- $\mu$ F decoupling capacitors. Often a larger capacitor (2.2  $\mu$ F, typical) is used along with a high-frequency, 0.1- $\mu$ F supply decoupling capacitor at the device supply pins. For single-supply operation, only the positive supply has these capacitors. When a split supply is used, use these capacitors for each supply to ground. If necessary, place the larger capacitors somewhat farther from the device and share these capacitors among several devices in the same area of the PCB. Avoid narrow power and ground traces to minimize inductance between the pins and the decoupling capacitors. An optional supply decoupling capacitor across the two power supplies (for bipolar operation) improves second-harmonic distortion performance.

## 11 Layout

### 11.1 Layout Guidelines

The *OPA835DBV*, *OPA836DBV EVM* (SLOU314) must be used as a reference when designing the circuit board. Follow the EVM layout of the external components near to the amplifier, ground plane construction, and power routing as closely as possible. General guidelines are:

1. Signal routing must be direct and as short as possible into an out of the operational amplifier.
2. The feedback path must be short and direct avoiding vias if possible especially with  $G = +1$ .
3. Ground or power planes must be removed from directly under the negative input and output pins of the amplifier.
4. A series output resistor is recommended to be placed as near to the output pin as possible. See [Figure 17](#) for recommended values given expected capacitive load of design.
5. A 2.2- $\mu$ F power-supply decoupling capacitor must be placed within 2 inches of the device and can be shared with other operational amplifiers. For split supply, a capacitor is required for both supplies.
6. A 0.1- $\mu$ F power-supply decoupling capacitor must be placed as near to the power supply pins as possible. Preferably within 0.1 inch. For split supply, a capacitor is required for both supplies.

## 11.2 Layout Example

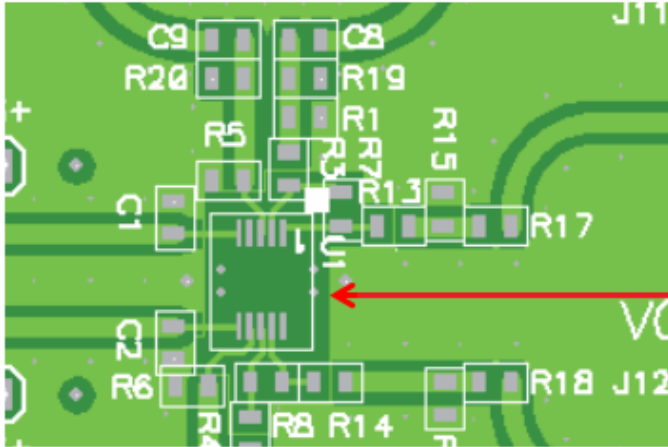

Dark green areas indicate regions of the PCB where the underlying Ground and Power Planes have been removed in order to minimize parasitic capacitance on the sensitive input and output nodes.

Figure 78. Top Layer

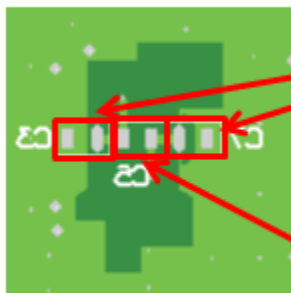

C3 and C7 are 0.1- $\mu$ F bypass capacitors placed directly underneath the device power supply pins.

C5 is a bypass capacitor between the supply pins. Use this when configuring the amplifier with bipolar supplies to improve HD2 performance.

Figure 79. Bottom Layer

## 12 器件和文档支持

### 12.1 器件支持

#### 12.1.1 开发支持

[WEBENCH® Filter Designer](#)

#### 12.1.2 相关文档

相关文档如下：

- [《OPA835DBV、OPA836DBV EVM》](#)（文献编号：SLOU314）
- [《ADS8326 16 位高速 2.7V 至 5.5V 低功耗采样模数转换器》](#)（文献编号：SBAS343）

### 12.2 相关链接

表 5 列出了快速访问链接。范围包括技术文档、支持与社区资源、工具和软件，以及样片或购买的快速访问。

表 5. 相关链接

| 器件         | 产品文件夹                 | 样片与购买                 | 技术文档                  | 工具与软件                 | 支持与社区                 |
|------------|-----------------------|-----------------------|-----------------------|-----------------------|-----------------------|
| OPA2836-Q1 | <a href="#">请单击此处</a> | <a href="#">请单击此处</a> | <a href="#">请单击此处</a> | <a href="#">请单击此处</a> | <a href="#">请单击此处</a> |

### 12.3 接收文档更新通知

如需接收文档更新通知，请访问 [www.ti.com.cn](http://www.ti.com.cn) 网站上的器件产品文件夹。点击右上角的提醒我 (Alert me) 注册后，即可每周定期收到已更改的产品信息。有关更改的详细信息，请查阅已修订文档中包含的修订历史记录。

### 12.4 社区资源

The following links connect to TI community resources. Linked contents are provided "AS IS" by the respective contributors. They do not constitute TI specifications and do not necessarily reflect TI's views; see TI's [Terms of Use](#).

**TI E2E™ Online Community** *TI's Engineer-to-Engineer (E2E) Community*. Created to foster collaboration among engineers. At [e2e.ti.com](http://e2e.ti.com), you can ask questions, share knowledge, explore ideas and help solve problems with fellow engineers.

**Design Support** *TI's Design Support* Quickly find helpful E2E forums along with design support tools and contact information for technical support.

### 12.5 商标

E2E is a trademark of Texas Instruments.

WEBENCH is a registered trademark of Texas Instruments.

All other trademarks are the property of their respective owners.

### 12.6 静电放电警告



ESD 可能会损坏该集成电路。德州仪器 (TI) 建议通过适当的预防措施处理所有集成电路。如果不遵守正确的处理措施和安装程序，可能会损坏集成电路。

ESD 的损坏小至导致微小的性能降级，大至整个器件故障。精密的集成电路可能更容易受到损坏，这是因为非常细微的参数更改都可能会导致器件与其发布的规格不相符。

### 12.7 Glossary

[SLYZ022](#) — *TI Glossary*.

This glossary lists and explains terms, acronyms, and definitions.

## 13 机械、封装和可订购信息

以下页中包括机械、封装和可订购信息。这些信息是针对指定器件可提供的最新数据。这些数据会在无通知且不对本文档进行修订的情况下发生改变。欲获得该数据表的浏览器版本，请查阅左侧的导航栏。

**PACKAGING INFORMATION**

| Orderable Device | Status<br>(1) | Package Type | Package Drawing | Pins | Package Qty | Eco Plan<br>(2) | Lead finish/<br>Ball material<br>(6) | MSL Peak Temp<br>(3) | Op Temp (°C) | Device Marking<br>(4/5) | Samples        |
|------------------|---------------|--------------|-----------------|------|-------------|-----------------|--------------------------------------|----------------------|--------------|-------------------------|----------------|
| OPA2836QDGKRQ1   | ACTIVE        | VSSOP        | DGK             | 8    | 2500        | RoHS & Green    | NIPDAUAG                             | Level-2-260C-1 YEAR  | -40 to 125   | 2836Q                   | <b>Samples</b> |

(1) The marketing status values are defined as follows:

**ACTIVE:** Product device recommended for new designs.

**LIFEBUY:** TI has announced that the device will be discontinued, and a lifetime-buy period is in effect.

**NRND:** Not recommended for new designs. Device is in production to support existing customers, but TI does not recommend using this part in a new design.

**PREVIEW:** Device has been announced but is not in production. Samples may or may not be available.

**OBSOLETE:** TI has discontinued the production of the device.

(2) **RoHS:** TI defines "RoHS" to mean semiconductor products that are compliant with the current EU RoHS requirements for all 10 RoHS substances, including the requirement that RoHS substance do not exceed 0.1% by weight in homogeneous materials. Where designed to be soldered at high temperatures, "RoHS" products are suitable for use in specified lead-free processes. TI may reference these types of products as "Pb-Free".

**RoHS Exempt:** TI defines "RoHS Exempt" to mean products that contain lead but are compliant with EU RoHS pursuant to a specific EU RoHS exemption.

**Green:** TI defines "Green" to mean the content of Chlorine (Cl) and Bromine (Br) based flame retardants meet JS709B low halogen requirements of <=1000ppm threshold. Antimony trioxide based flame retardants must also meet the <=1000ppm threshold requirement.

(3) MSL, Peak Temp. - The Moisture Sensitivity Level rating according to the JEDEC industry standard classifications, and peak solder temperature.

(4) There may be additional marking, which relates to the logo, the lot trace code information, or the environmental category on the device.

(5) Multiple Device Markings will be inside parentheses. Only one Device Marking contained in parentheses and separated by a "-" will appear on a device. If a line is indented then it is a continuation of the previous line and the two combined represent the entire Device Marking for that device.

(6) Lead finish/Ball material - Orderable Devices may have multiple material finish options. Finish options are separated by a vertical ruled line. Lead finish/Ball material values may wrap to two lines if the finish value exceeds the maximum column width.

**Important Information and Disclaimer:**The information provided on this page represents TI's knowledge and belief as of the date that it is provided. TI bases its knowledge and belief on information provided by third parties, and makes no representation or warranty as to the accuracy of such information. Efforts are underway to better integrate information from third parties. TI has taken and continues to take reasonable steps to provide representative and accurate information but may not have conducted destructive testing or chemical analysis on incoming materials and chemicals. TI and TI suppliers consider certain information to be proprietary, and thus CAS numbers and other limited information may not be available for release.

In no event shall TI's liability arising out of such information exceed the total purchase price of the TI part(s) at issue in this document sold by TI to Customer on an annual basis.



DGK (S-PDSO-G8)

PLASTIC SMALL-OUTLINE PACKAGE



- NOTES:
- A. All linear dimensions are in millimeters.
  - B. This drawing is subject to change without notice.
  - C. Body length does not include mold flash, protrusions, or gate burrs. Mold flash, protrusions, or gate burrs shall not exceed 0.15 per end.
  - D. Body width does not include interlead flash. Interlead flash shall not exceed 0.50 per side.
  - E. Falls within JEDEC MO-187 variation AA, except interlead flash.



- NOTES:
- A. All linear dimensions are in millimeters.
  - B. This drawing is subject to change without notice.
  - C. Publication IPC-7351 is recommended for alternate designs.
  - D. Laser cutting apertures with trapezoidal walls and also rounding corners will offer better paste release. Customers should contact their board assembly site for stencil design recommendations. Refer to IPC-7525 for other stencil recommendations.
  - E. Customers should contact their board fabrication site for solder mask tolerances between and around signal pads.

## 重要声明和免责声明

TI 均以“原样”提供技术性及其可靠性数据（包括数据表）、设计资源（包括参考设计）、应用或其他设计建议、网络工具、安全信息和其他资源，不保证其中不含任何瑕疵，且不做任何明示或暗示的担保，包括但不限于对适销性、适合某特定用途或不侵犯任何第三方知识产权的暗示担保。

所述资源可供专业开发人员应用TI 产品进行设计使用。您将对以下行为独自承担全部责任：(1) 针对您的应用选择合适的TI 产品；(2) 设计、验证并测试您的应用；(3) 确保您的应用满足相应标准以及任何其他安全、安保或其他要求。所述资源如有变更，恕不另行通知。TI 对您使用所述资源的授权仅限于开发资源所涉及TI 产品的相关应用。除此之外不得复制或展示所述资源，也不提供其它TI 或任何第三方的知识产权授权许可。如因使用所述资源而产生任何索赔、赔偿、成本、损失及债务等，TI 对此概不负责，并且您须赔偿由此对TI 及其代表造成的损害。

TI 所提供产品均受TI 的销售条款 (<http://www.ti.com.cn/zh-cn/legal/termsofsale.html>) 以及ti.com.cn 上或随附TI 产品提供的其他可适用条款的约束。TI 提供所述资源并不扩展或以其他方式更改TI 针对TI 产品所发布的可适用的担保范围或担保免责声明。

邮寄地址：上海市浦东新区世纪大道 1568 号中建大厦 32 楼，邮政编码：200122

Copyright © 2020 德州仪器半导体技术（上海）有限公司