

TPS65265 4.5V 至 17V 输入电压、5A/3A/2A 输出电流三路同步降压转换器

1 特性

- 工作输入电压范围：4.5V 至 17V
- 反馈基准电压：0.6V±1.33%
- 持续输出电流：5A/3A/2A
- 可调节时钟频率范围：250kHz 至 2.3MHz
- 外部同步振荡器
- Buck1、Buck2 和 Buck3 之间具有 120° 相位差
- 针对每个降压转换器的专用使能引脚
- 针对每个降压转换器的固定软启动 (SS) 时间 (2.4ms)
- 自动加电/断电序列以及各降压转换器间可调节的间隔时间 (6 种组合)
- 支持脉冲跳跃模式 (PSM) 和强制持续电流模式 (FCCM)
- 输出电压正常指示器和可调节的延迟时间
- 热过载保护
- 32 引脚 5mm x 5mm 四方扁平无引线 (QFN) (RHB) 封装

2 应用范围

- 数字电视 (DTV)
- 机顶盒/OTT
- 家庭网关和接入点网络
- 安全监控

3 说明

TPS65265 整合了三路同步降压转换器，支持 4.5V 至 17V 宽范围输入电压，该电压范围包括大部分中间总线关闭电压为 5、9、12 或 15V 的电源总线或电池。这款转换器具有恒定频率峰值电流模式，专用于简化应用，同时方便设计人员根据目标应用来优化系统。可通过外部电阻或外部时钟在 250kHz 至 2.3MHz 范围内调节转换器的开关频率。Buck1、Buck2 和 Buck3 之间的 120° 异相运行可最大限度降低对输入滤波器的要求。

TPS65265 可通过将 MODE 引脚驱动为高电平或保持悬空进入脉冲跳跃模式 (PSM)，通过将 MODE 引脚连接至 GND 进入强制持续电流模式 (FCC)。PSM 模式通过减少轻负载时的开关损耗来提供高效率，而 FCC 模式可降低噪声灵敏度和射频 (RF) 干扰。

TPS65265 采用 32 引脚 5mm x 5mm 耐热增强型 QFN (RHB) 薄型封装。

器件信息(1)

器件型号	封装	封装尺寸 (标称值)
TPS65265	VQFN (32)	5.00mm x 5.00mm

(1) 要了解所有可用封装，请见数据表末尾的可订购产品附录。

简化应用电路

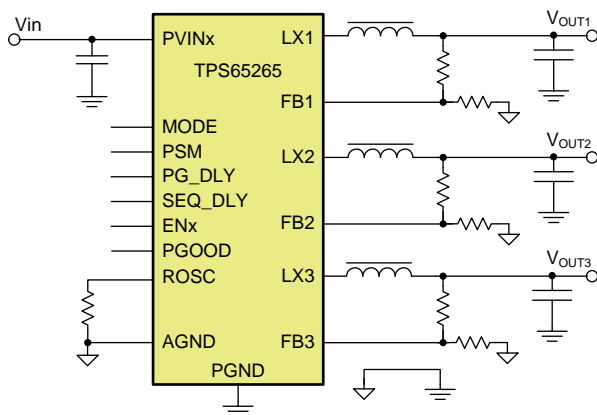

效率与输出负载之间的关系

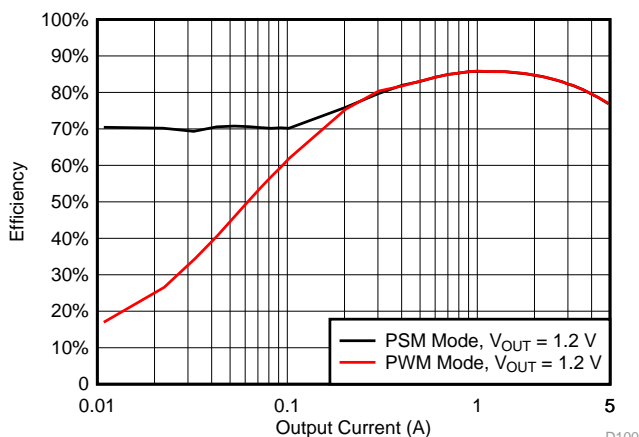

D100



目录

1	特性	1	8.3	Feature Description	13
2	应用范围	1	8.4	Device Functional Modes	24
3	说明	1	9	Application and Implementation	26
4	修订历史记录	2	9.1	Application Information	26
5	Related Parts	3	9.2	Typical Application	26
6	Pin Configuration and Functions	3	10	Power Supply Recommendations	37
7	Specifications	5	11	Layout	37
7.1	Absolute Maximum Ratings	5	11.1	Layout Guidelines	37
7.2	ESD Ratings	5	11.2	Layout Example	38
7.3	Recommended Operating Conditions	5	12	器件和文档支持	39
7.4	Thermal Information	5	12.1	社区资源	39
7.5	Electrical Characteristics	6	12.2	商标	39
7.6	Typical Characteristics	7	12.3	静电放电警告	39
8	Detailed Description	12	12.4	Glossary	39
8.1	Overview	12	13	机械、封装和可订购信息	39
8.2	Functional Block Diagram	13			

4 修订历史记录

Changes from Original (December 2015) to Revision A

Page

• 已将器件状态更改为量产数据且已发布完整数据表	1
--------------------------------	----------

5 Related Parts

PART NUMBER	DESCRIPTION	COMMENTS
TPS65261/-1	4.5 V to 18 V, triple bucks with input voltage power failure indicator	Triple bucks 3-A/2-A/2-A output current, features an open drain RESET signal to monitor input power failure, automatic power sequencing
TPS65262/-1	4.5 V to 18 V, triple bucks with dual adjustable LDOs	Triple bucks 3-A/1-A/1-A output current, automatic power sequencing, dual LDOs 100 mA/200 mA for TPS65262, 350 mA/150 mA for TPS65262-1
TPS65263	4.5 V to 18 V, triple bucks with I ² C interface	Triple bucks 3-A/2-A/2-A output current, I ² C controlled dynamic voltage scaling (DVS)
TPS65266	2.7 V to 6.5 V, triple bucks	Triple bucks 3-A/2-A/2-A

6 Pin Configuration and Functions

**RHB Package
32-Lead Plastic QFN
Top View**

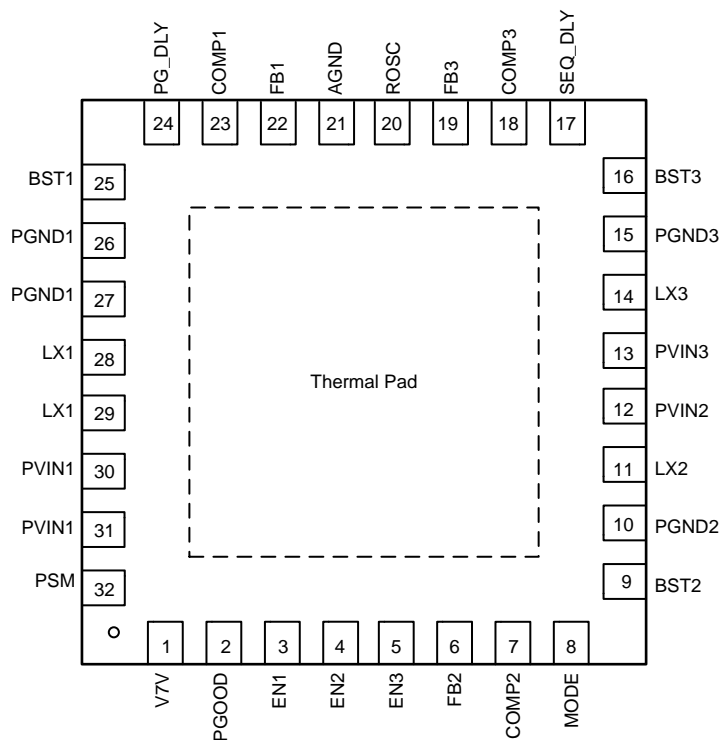

NOTE:: There is no electric signal down bonded to thermal pad inside IC. Exposed thermal pad must be soldered to PCB for optimal thermal performance.

Pin Functions

PIN		DESCRIPTION
NO.	NAME	
1	V7V	Internal LDO for gate driver and internal controller. Connect a 1 μ F capacitor from the pin to power ground
2	PGOOD	An open drain output, asserts low if output voltage of any buck beyond regulation range due to thermal shutdown, over-current, under-voltage or ENx shut down.
3	EN1	Enable for buck1. Float to enable. Can use this pin to adjust the input undervoltage lockout (UVLO) of buck1 with a resistor divider.
4	EN2	Enable for buck2. Float to enable. Can use this pin to adjust the input UVLO of buck2 with a resistor divider.
5	EN3	Enable for buck3. Float to enable. Can use this pin to adjust the input UVLO of buck3 with a resistor divider.
6	FB2	Feedback Kelvin sensing pin for buck2 output voltage. Connect this pin to buck2 resistor divider.
7	COMP2	Error amplifier output and Loop compensation pin for buck2. Connect a series resistor and capacitor to compensate the control loop of buck2 with peak current PWM mode.
8	MODE	When floating, Buck1/2/3 are controlled separate by EN1/2/3. When tied to HIGH or tied to GND, an automatic power-up/power-down sequence is provided according to states of EN1, EN2 and EN3 pins.
9	BST2	Boot strapped supply to the high side floating gate driver in buck2. Connect a capacitor (recommend 47nF) from BST2 pin to LX2 pin.
10	PGND2	Power ground connection of buck2. Connect PGND2 pin as close as practical to the (-) terminal of PVIN2 input ceramic capacitor.
11	LX2	Switching node connection to the inductor and bootstrap capacitor for buck2. The voltage swing at this pin is from a diode voltage below the ground up to PVIN2 voltage.
12	PVIN2	Input power supply for buck2. Connect PVIN2 pin as close as practical to the (+) terminal of an input ceramic capacitor (suggest 10 μ F).
13	PVIN3	Input power supply for buck3. Connect PVIN3 pin as close as practical to the (+) terminal of an input ceramic capacitor (suggest 10 μ F).
14	LX3	Switching node connection to the inductor and bootstrap capacitor for buck3. The voltage swing at this pin is from a diode voltage below the ground up to PVIN3 voltage.
15	PGND3	Power ground connection of buck3. Connect PGND3 pin as close as practical to the (-) terminal of PVIN3 input ceramic capacitor.
16	BST3	Boot strapped supply to the high side floating gate driver in buck3. Connect a capacitor (recommend 47nF) from BST3 pin to LX3 pin.
17	SEQ_DLY	Delay time programmable between bucks at automatic power sequencing mode. Connect an external capacitor to set the interval delay time.
18	COMP3	Error amplifier output and Loop compensation pin for buck3. Connect a series resistor and capacitor to compensate the control loop of buck3 with peak current PWM mode.
19	FB3	Feedback Kelvin sensing pin for buck3 output voltage. Connect this pin to buck3 resistor divider.
20	ROSC	Oscillator frequency programmable pin. Connect an external resistor to set the switching frequency.
21	AGND	Analog ground common to buck controllers and other analog circuits.
22	FB1	Feedback Kelvin sensing pin for buck1 output voltage. Connect this pin to buck1 resistor divider.
23	COMP1	Error amplifier output and Loop compensation pin for buck1. Connect a series resistor and capacitor to compensate the control loop of buck1 with peak current PWM mode.
24	PG_DLY	PGOOD delay programmable pin. Connect an external capacitor to set the delay time.
25	BST1	Boot strapped supply to the high side floating gate driver in buck1. Connect a capacitor (recommend 47nF) from BST1 pin to LX1 pin.
26, 27	PGND1	Power ground connection of Buck1. Connect PGND1 pin as close as practical to the (-) terminal of PVIN1 input ceramic capacitor.
28, 29	LX1	Switching node connection to the inductor and bootstrap capacitor for buck1. The voltage swing at this pin is from a diode voltage below the ground up to PVIN1 voltage.
30, 31	PVIN1	Input power supply for buck1. Connect PVIN1 pin as close as practical to the (+) terminal of an input ceramic capacitor (suggest 22 μ F).
32	PSM	Ties to HIGH or leaves floating, PSM mode; Ties to GND, FCCM mode.
PAD		There is no electric signal down bonded to thermal pad inside IC. Exposed thermal pad must be soldered to PCB for optimal thermal performance.

7 Specifications

7.1 Absolute Maximum Ratings

over operating free-air temperature range (unless otherwise noted)⁽¹⁾

	MIN	MAX	UNIT
PVIN1, PVIN2, PVIN3, PGOOD	−0.3	20	V
LX1, LX2, LX3	−1.0	19	V
LX1, LX2, LX3 (maximum withstand voltage transient <10 ns)	−1.0	21	V
BST1, BST2, BST3 referenced to LX1, LX2, LX3 pins, respectively	−0.3	7	V
EN1, EN2, EN3, V7V, MODE, PSM	−0.3	7	V
FB1, FB2, FB3, COMP1, COMP2, COMP3, ROSC, SEQ_DLY, PG_DLY	−0.3	3.6	V
AGND, PGND1, PGND2, PGND3	−0.3	0.3	V
Operating junction temperature, T _J	−40	150	°C
Storage temperature, T _{stg}	−55	150	°C

- (1) Stresses beyond those listed under *Absolute Maximum Ratings* may cause permanent damage to the device. These are stress ratings only, which do not imply functional operation of the device at these or any other conditions beyond those indicated under *Recommended Operating Conditions*. Exposure to absolute-maximum-rated conditions for extended periods may affect device reliability.

7.2 ESD Ratings

		VALUE	UNIT
V _(ESD) Electrostatic discharge	Human-body model (HBM), per ANSI/ESDA/JEDEC JS-001 ⁽¹⁾	±2000	V
	Charged-device model (CDM), per JEDEC specification JESD22-C101 ⁽²⁾	±1000	

- (1) JEDEC document JEP155 states that 500-V HBM allows safe manufacturing with a standard ESD control process.
(2) JEDEC document JEP157 states that 250-V CDM allows safe manufacturing with a standard ESD control process.

7.3 Recommended Operating Conditions

over operating free-air temperature range (unless otherwise noted)

	MIN	MAX	UNIT
PVIN1, PVIN2, PVIN3	4.5	17	V
LX1, LX2, LX3 (Maximum withstand voltage transient <10 ns)	−0.8	19	V
BST1, BST2, BST3 referenced to LX1, LX2, LX3 pins respectively	−0.1	6.8	V
EN1, EN2, EN3, V7V, MODE, PSM	−0.1	6.3	V
FB1, FB2, FB3, COMP1, COMP2, COMP3, ROSC, SEQ_DLY, PG_DLY	−0.1	3.3	V
Operating junction temperature, T _J	−40	125	°C

7.4 Thermal Information

THERMAL METRIC ⁽¹⁾		TPS65265	UNIT
		RHB (QFN)	
		32 PINS	
R _{θJA}	Junction-to-ambient thermal resistance	32	°C/W
R _{θJC(top)}	Junction-to-case (top) thermal resistance	24.2	°C/W
R _{θJB}	Junction-to-board thermal resistance	6.4	°C/W
ψ _{JT}	Junction-to-top characterization parameter	0.2	°C/W
ψ _{JB}	Junction-to-board characterization parameter	6.4	°C/W
R _{θJC(bot)}	Junction-to-case (bottom) thermal resistance	1.3	°C/W

- (1) For more information about traditional and new thermal metrics, see the *Semiconductor and IC Package Thermal Metrics* application report, [SPRA953](#).

7.5 Electrical Characteristics

 $T_J = -40^{\circ}\text{C}$ to 125°C , typical values are at $T_J = 25^{\circ}\text{C}$ (unless otherwise noted)

PARAMETER		TEST CONDITIONS	MIN	TYP	MAX	UNIT
INPUT SUPPLY VOLTAGE						
V_{IN}	Input voltage range		4.5		17	V
$UVLO$	V_{IN} undervoltage lockout	V_{IN} rising	3.6	3.8	4	V
		V_{IN} falling	3.0	3.2	3.4	V
		Hysteresis		600		mV
IDD_{SDN}	Shutdown supply current	$PV_{IN} = 12\text{ V}$, $EN1 = EN2 = EN3 = MODE = 0\text{ V}$	9	11.5	14	μA
IDD_{Q_NSW}	Input quiescent current without buck1/2/3 switching	$EN1 = EN2 = EN3 = 5\text{ V}$, $FB1 = FB2 = FB3 = 0.8\text{ V}$	550	680	800	μA
IDD_{Q_NSW1}		$EN1 = 5\text{ V}$, $EN2 = EN3 = 0\text{ V}$, $FB1 = 0.8\text{ V}$	280	350	425	μA
IDD_{Q_NSW2}		$EN2 = 5\text{ V}$, $EN1 = EN3 = 0\text{ V}$, $FB2 = 0.8\text{ V}$	280	350	425	μA
IDD_{Q_NSW3}		$EN3 = 5\text{ V}$, $EN1 = EN2 = 0\text{ V}$, $FB3 = 0.8\text{ V}$	280	350	425	μA
V_{7V}	V7V LDO output voltage	$PV_{IN1} = 12\text{ V}$, V_{7V} load current = 0 A	5.9	6.1	6.3	V
I_{OCP_V7V}	V7V LDO current limit		110	177	235	mA
FEEDBACK VOLTAGE REFERENCE						
V_{FB}	Feedback voltage	$V_{COMP} = 1.2\text{ V}$	0.592	0.6	0.608	V
Buck1, Buck2, Buck3						
V_{ENXH}	EN1/2/3 high-level input voltage		1.08	1.15	1.22	V
V_{ENXL}	EN1/2/3 low-level input voltage		1.06	1.12	1.17	V
I_{ENX1}	EN1/2/3 pullup current	$ENx = 1\text{ V}$	2.3	2.9	3.4	μA
I_{ENX2}	EN1/2/3 pullup current	$ENx = 1.5\text{ V}$	5.1	6	6.8	μA
I_{ENhys}	hysteresis current			3.1		μA
t_{ON_MIN}	Minimum on time	$I_{load} = 100\text{ mA}$		75	120	ns
G_{m_EA}	Error amplifier transconductance	$-2\text{ }\mu\text{A} < I_{COMPX} < 2\text{ }\mu\text{A}$	174	350	530	μS
$G_{m_PS1/2/3}$	COMP1/2/3 voltage to inductor current $G_m^{(1)}$	$I_{LX} = 0.5\text{ A}$		12		A/V
I_{LIMIT1}	buck1 peak inductor current limit		6.0	8.0	9.6	A
$I_{LIMITSOURCE1}$	buck1 low-side source current limit		5.3	7.7	10	A
$I_{LIMITSINK1}$	buck1 low-side sink current limit			1.4		A
I_{LIMIT2}	buck2 peak inductor current limit		3.85	5.2	6.65	A
$I_{LIMITSOURCE2}$	buck2 low-side source current limit		3	4.8	5.5	A
$I_{LIMITSINK2}$	buck2 low-side sink current limit			1.2		A
I_{LIMIT3}	buck3 peak inductor current limit		2.6	3.6	4.45	A
$I_{LIMITSOURCE3}$	buck3 low-side source current limit		2.6	3.7	4.6	A
$I_{LIMITSINK3}$	buck3 low-side sink current limit			1.2		A
t_{Hiccup_wait}	Overcurrent wait time ⁽¹⁾			256		cycles
t_{Hiccup_re}	Hiccup time before restart ⁽¹⁾			8192		cycles
R_{dson_HS1}	buck1 high-side switch resistance	$PV_{IN} = 12\text{ V}$		39		m Ω
R_{dson_LS1}	buck1 low-side switch resistance	$PV_{IN} = 12\text{ V}$		25		m Ω
R_{dson_HS2}	buck2 high-side switch resistance	$PV_{IN} = 12\text{ V}$		52		m Ω
R_{dson_LS2}	buck2 low-side switch resistance	$PV_{IN} = 12\text{ V}$		43		m Ω
R_{dson_HS3}	buck3 high-side switch resistance	$PV_{IN} = 12\text{ V}$		70		m Ω
R_{dson_LS3}	buck3 low-side switch resistance	$PV_{IN} = 12\text{ V}$		65		m Ω

(1) Lab validation result

Electrical Characteristics (continued)

$T_J = -40^{\circ}\text{C}$ to 125°C , typical values are at $T_J = 25^{\circ}\text{C}$ (unless otherwise noted)

PARAMETER	TEST CONDITIONS	MIN	TYP	MAX	UNIT
PGOOD, MODE, PSM, SEQ_DLY, PG_DLY					
V_{th_PG}	Feedback voltage threshold	FBx undervoltage falling	92.5		%VREF
		FBx undervoltage rising	95		%VREF
		FBx overvoltage rising	107.5		%VREF
		FBx overvoltage falling	105		%VREF
$t_{DEGLITCH(PG_F)}$	PGOOD falling edge deglitch time		256		cycles
$t_{DEGLITCH(PG_R)}$	PGOOD rising edge deglitch time		256		cycles
I_{PG}	PGOOD pin leakage			0.08	μA
V_{LOW_PG}	PGOOD pin low voltage	PVIN1 = 12 V, $I_{SINK} = 1\text{ mA}$		0.25	V
V_{MODE_H}	MODE high level input voltage	2.4	2.6	2.8	V
V_{MODE_L}	MODE low level input voltage	0.11	0.16	0.23	V
V_{PG_DLYTH}	PG_DLY threshold	1.4	1.5	1.6	V
I_{PG_DLY}	PG_DLY pullup current	PG_DLY = 0.5 V		4.1	μA
V_{SEQ_DLYTH1}	SEQ_DLY threshold	0.7	0.75	0.8	V
V_{SEQ_DLYTH2}	SEQ_DLY threshold	1.4	1.5	1.58	V
I_{SEQ_DLY}	SEQ_DLY pullup current	SEQ_DLY = 0.5 V		4.1	μA
V_{PSMH}	PSM pin high level input voltage	1.3	1.4	1.55	V
V_{PSML}	PSM pin low level input voltage	1	1.1	1.2	V
OSCILLATOR					
F_{SW}	Switching frequency	$R_{OSC} = 82.5\text{ k}\Omega$		640	kHz
F_{SW_range}	Switching frequency	250		2300	kHz
t_{SYNC_w}	Clock sync minimum pulse width	80			ns
F_{SYNC_HI}	Clock sync high threshold			2	V
V_{SYNC_LO}	Clock sync low threshold	0.4			V
THERMAL PROTECTION					
T_{TRIP_OTP}	Thermal protection trip point ⁽¹⁾	Temperature rising		160	$^{\circ}\text{C}$
T_{HYST_OTP}		Hysteresis		20	$^{\circ}\text{C}$

7.6 Typical Characteristics

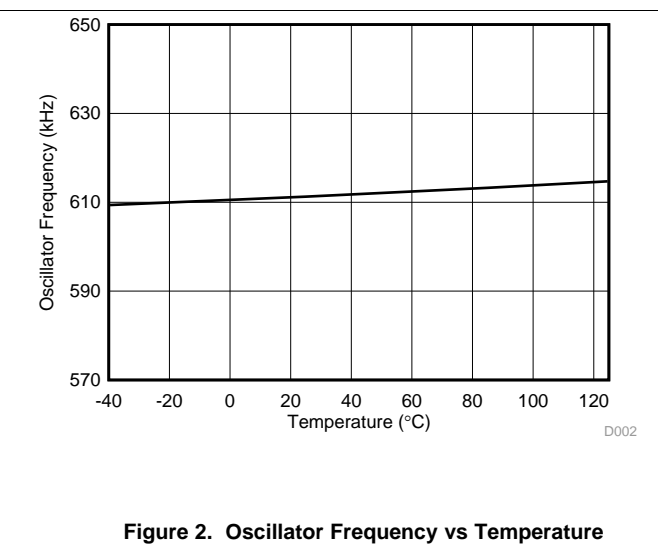
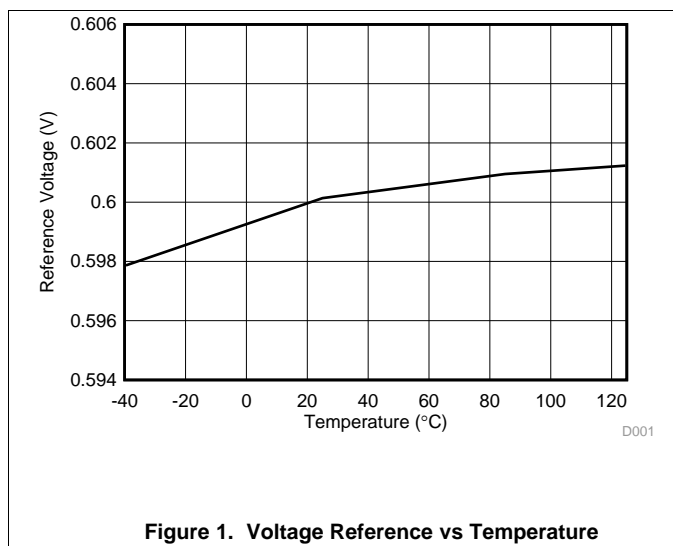

Typical Characteristics (continued)

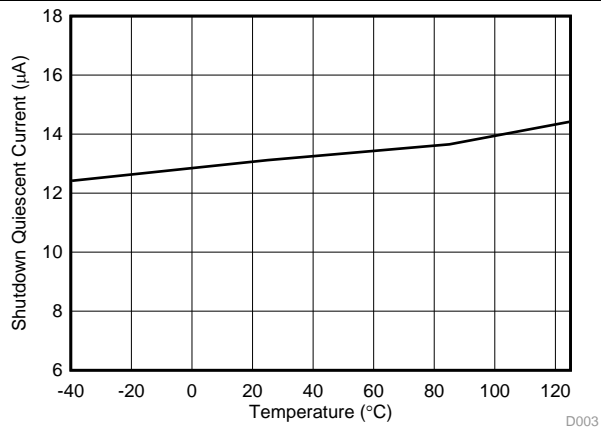

Figure 3. Shutdown Quiescent vs Temperature

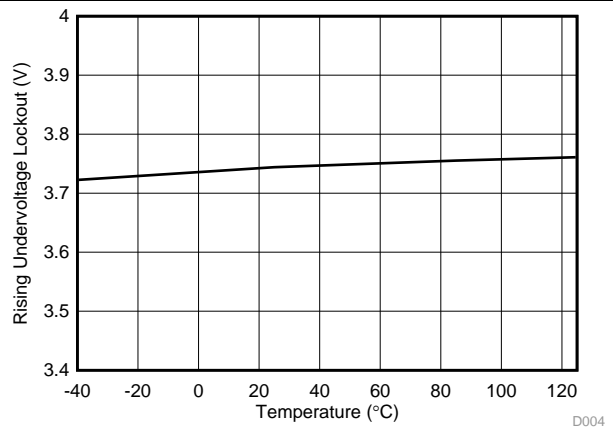

Figure 4. Vin UVLO Raising vs Temperature

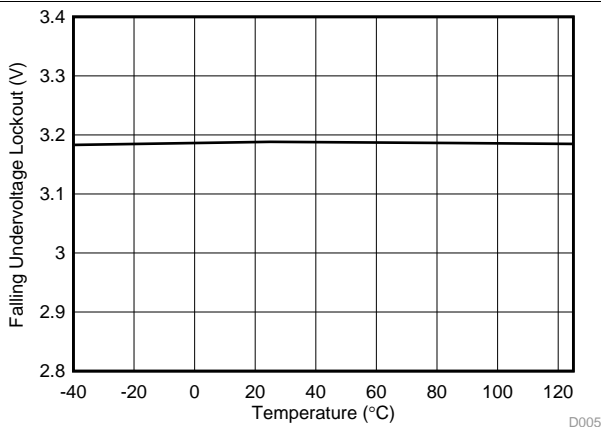

Figure 5. Vin UVLO Falling vs Temperature

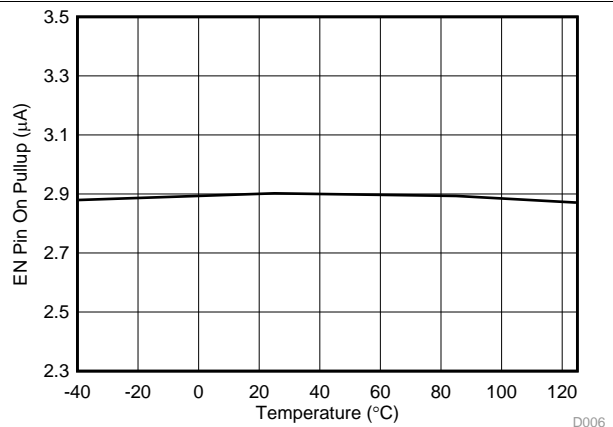

Figure 6. EN Pin Pullup Current vs Temperature, EN = 1.0 V

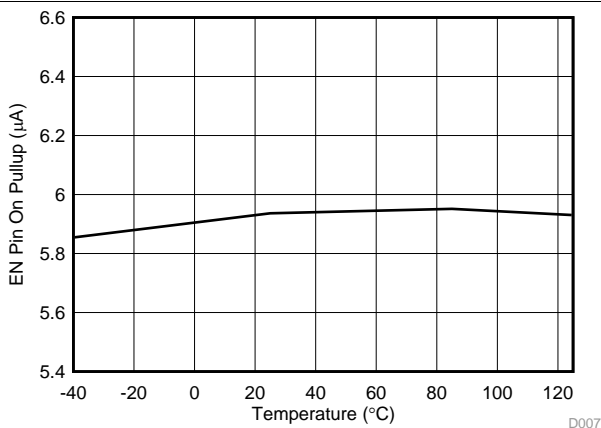

Figure 7. EN Pin Pullup Current vs Temperature, EN = 1.5 V

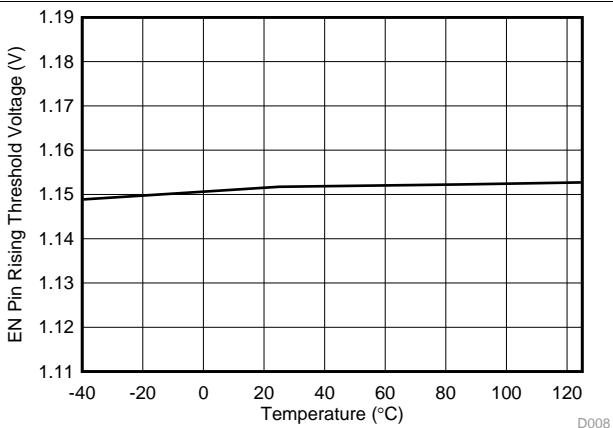

Figure 8. EN Pin Threshold Raising vs Temperature

Typical Characteristics (continued)

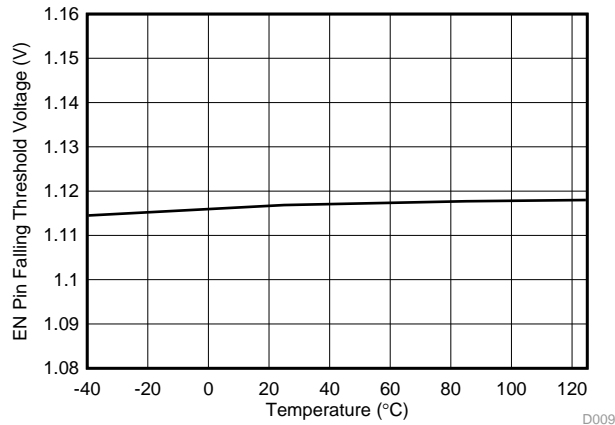

Figure 9. EN Pin Threshold Falling vs Temperature

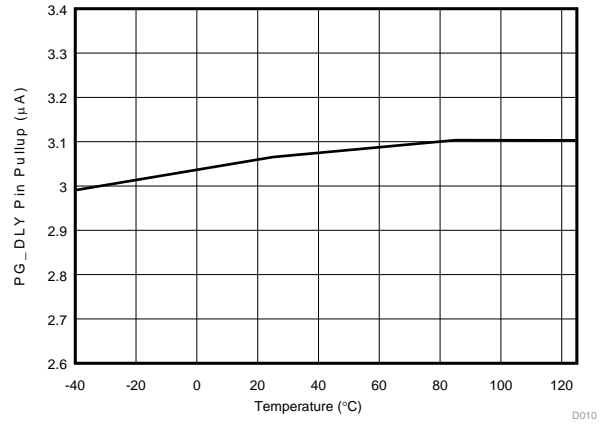

Figure 10. PG_DLY Pin Pullup Current vs Temperature, PG_DLY = 0.5 V

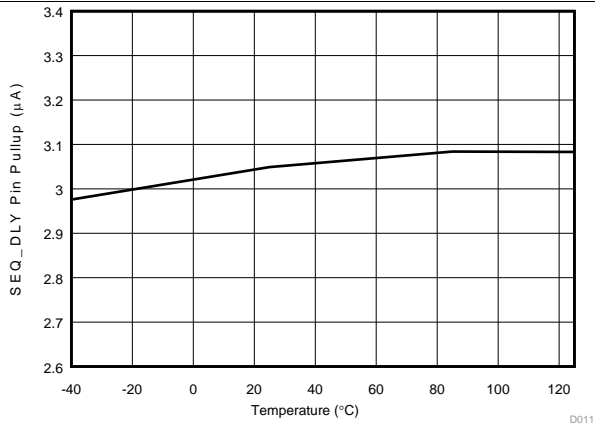

Figure 11. SEQ_DLY Pin Pullup Current vs Temperature, PG_DLY = 0.5 V

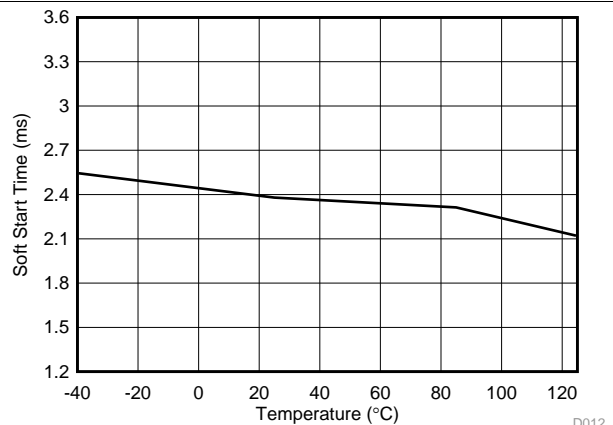

Figure 12. Soft-Start Time vs Temperature

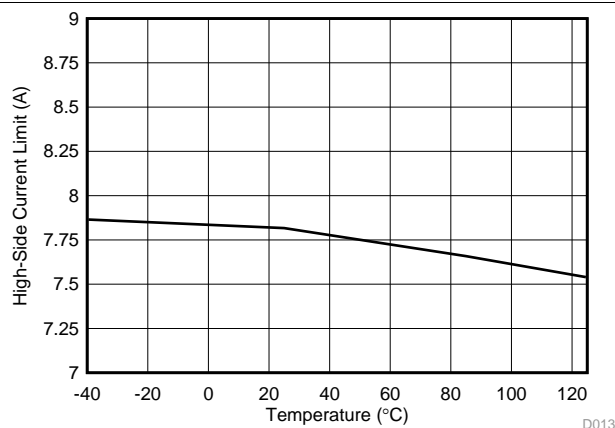

Figure 13. Buck1 High-Side Current Limit vs Temperature

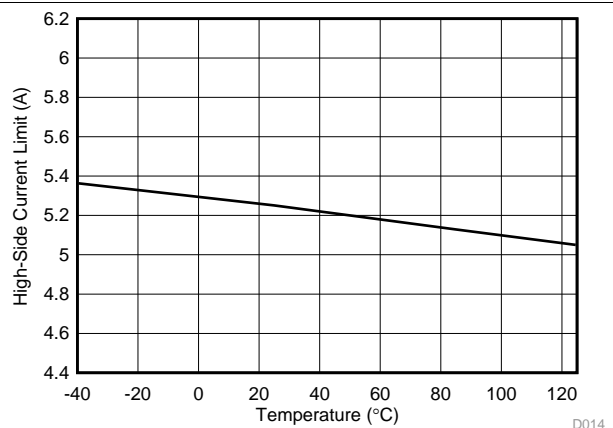

Figure 14. Buck2 High-Side Current Limit vs Temperature

Typical Characteristics (continued)

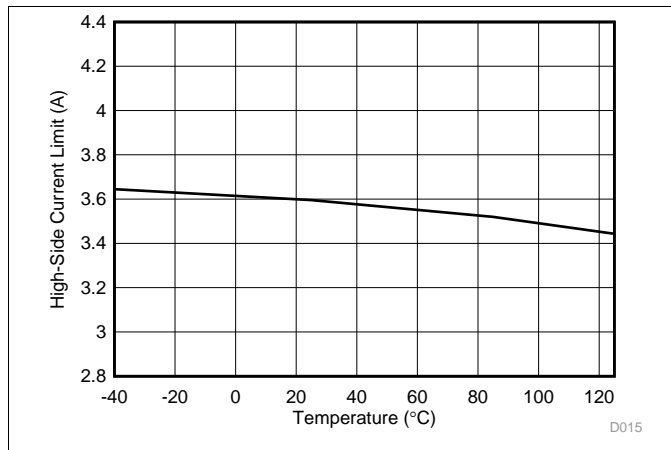

Figure 15. Buck3 High-Side Current Limit vs Temperature

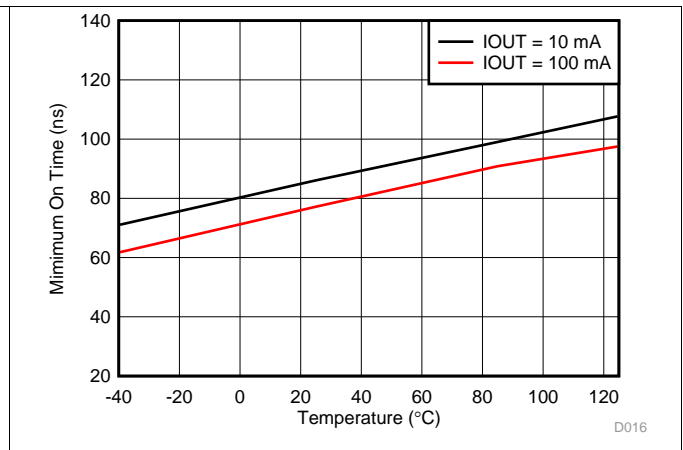

Figure 16. Minimum On Time vs Temperature

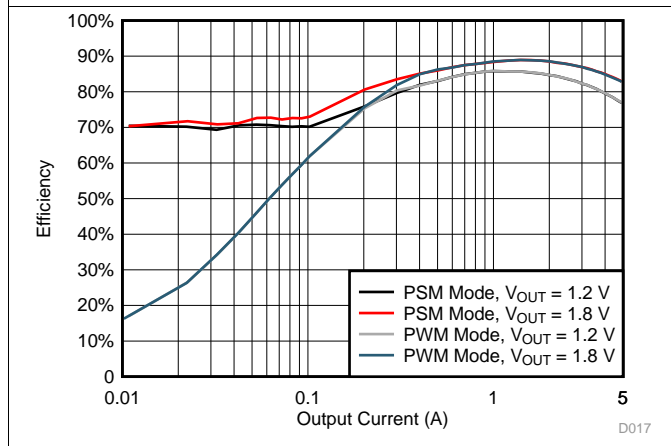

Figure 17. Buck1 Efficiency, $V_{IN} = 12\text{ V}$, $F_{sw} = 610\text{ kHz}$

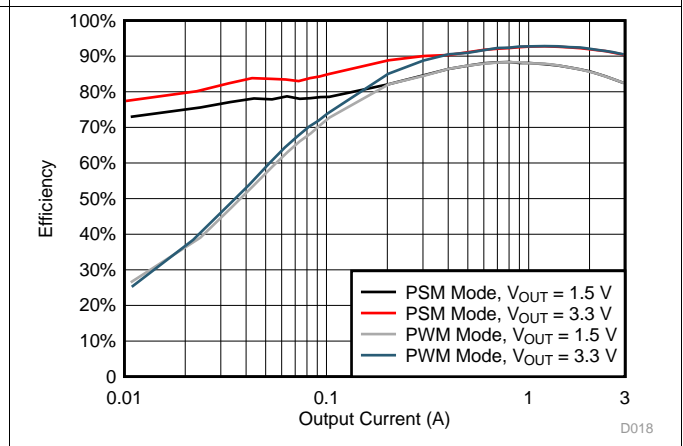

Figure 18. Buck2 Efficiency, $V_{IN} = 12\text{ V}$, $F_{sw} = 610\text{ kHz}$

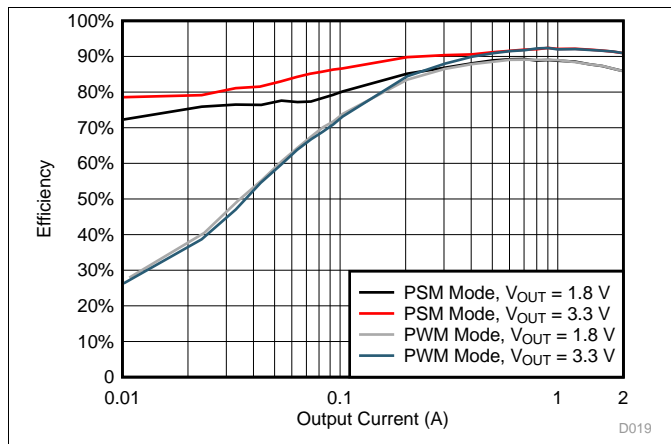

Figure 19. Buck3 Efficiency, $V_{IN} = 12\text{ V}$, $F_{sw} = 610\text{ kHz}$

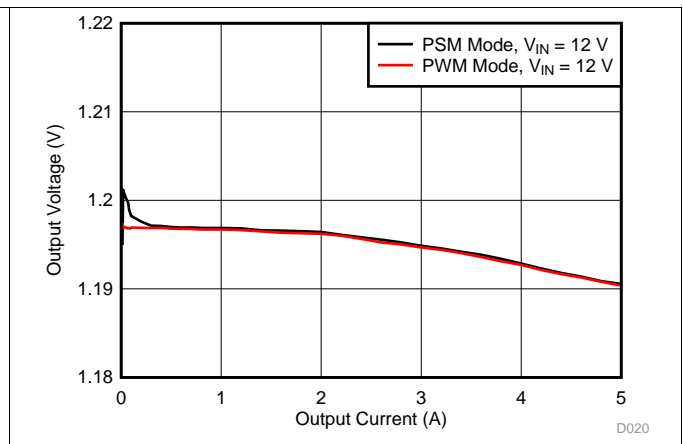
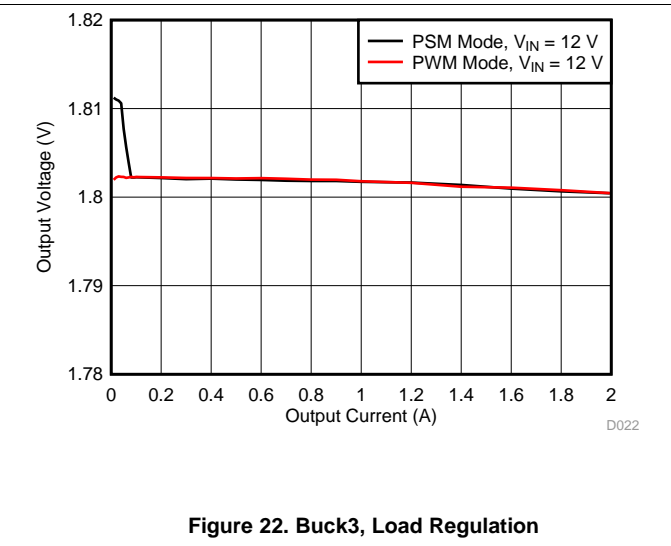
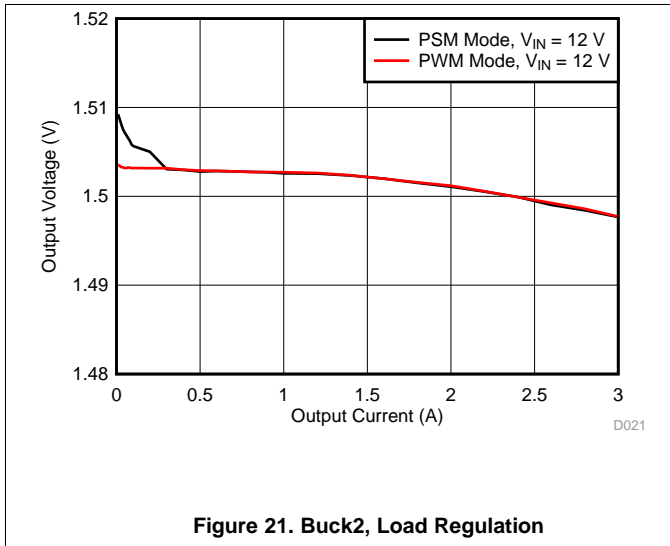

Figure 20. Buck1, Load Regulation

Typical Characteristics (continued)



8 Detailed Description

8.1 Overview

The TPS65265 is a monolithic triple synchronous step-down (buck) converter with 5-A/3-A/2-A output currents. A wide 4.5-V to 17-V input supply voltage range encompasses most intermediate bus voltages operating off 5-V, 9-V, 12-V, or 15-V power bus. The feedback voltage reference for each buck is 0.6 V. Each buck is independent with dedicated enable, soft-start and loop compensation pins.

The TPS65265 implements a constant frequency, peak current mode control that simplifies external loop compensation. The wide switching frequency of 250 kHz to 2.3 MHz allows optimizing system efficiency, filtering size and bandwidth. The switching frequency can be adjusted with an external resistor connecting between ROsc pin and ground. The switching clock is 120° out-of-phase operation from the clocks of buck1, buck2, and buck3 channels to reduce input current ripple, input capacitor size and power supply induced noise.

The TPS65265 has been designed for safe monotonic startup into pre-biased loads. The default start up is when VIN is typically 3.8 V. The ENx pin also can be used to adjust the input voltage undervoltage lockout (UVLO) with an external resistor divider. In addition, the ENx pin has an internal 2.9µA current source, so the EN pin can be floating for automatically powering up the converters.

The TPS65265 reduces the external component count by integrating the bootstrap circuit. The bias voltage for the integrated high-side MOSFET is supplied by a capacitor between the BST and LX pins. A UVLO circuit monitors the bootstrap capacitor voltage VBST-VLX in each buck. When $V_{BST}-V_{LX}$ voltage drops to the threshold, LX pin is pulled low to recharge the bootstrap capacitor. The TPS65265 can operate at 100% duty cycle as long as the bootstrap capacitor voltage is higher than the BOOT-LX UVLO threshold which is typically 2.2 V.

The TPS65265 features PGOOD pin to supervise each output voltage of buck converters. The TPS65265 has power good comparators with hysteresis, which monitor the output voltages through feedback voltages. When all bucks are in regulation range and power sequence is done, PGOOD is asserted to high after the adjustable delay time.

The TPS65265 operates in PSM with connecting PSM pin to high or leaving float and operates in force continuous current mode (FCC) with driving PSM pin to GND.

The TPS65265 is protected from overload and over temperature fault conditions. The converter minimizes excessive output overvoltage transients by taking advantage of the power good comparator. When the output is over, the high-side MOSFET is turned off until the internal feedback voltage is lower than 105% of the 0.6V reference voltage. The TPS65265 implements both high-side MOSFET overload protection and bidirectional low-side MOSFET overload protections to avoid inductor current runaway. If the overcurrent condition has lasted for more than the OC wait time (256 clock cycle), the converter will shut down and restart after the hiccup time (8192 clock cycles). The TPS65265 shuts down if the junction temperature is higher than thermal shutdown trip point. When the junction temperature drops 20°C typically below the thermal shutdown trip point, the TPS65265 will be restarted under control of the soft start circuit automatically.

8.2 Functional Block Diagram

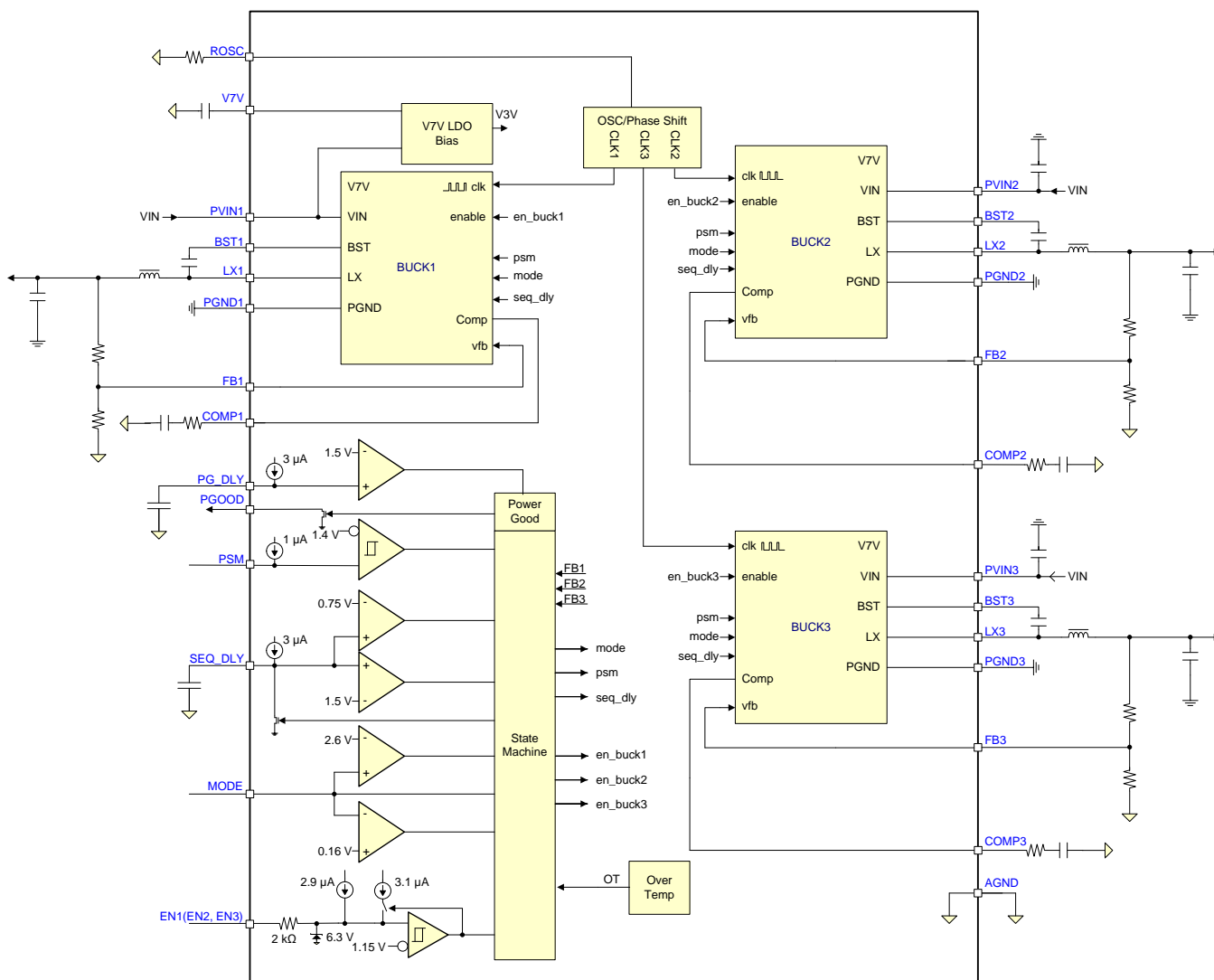

8.3 Feature Description

8.3.1 Adjusting the Output Voltage

The output voltage of each buck is set with a resistor divider from the output of buck to the FB pin. TI recommends to use 1% tolerance or better resistors.

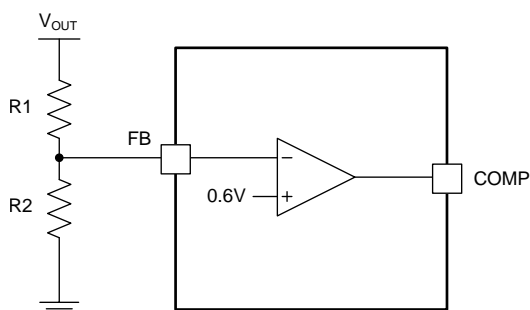

Figure 23. Voltage Divider Circuit

Feature Description (continued)

$$R_2 = R_1 \times \frac{0.6}{V_{out} - 0.6} \quad (1)$$

To improve efficiency at light loads consider using larger value resistors. If the values are too high, the regulator is more sensitive to noise. The recommended resistor values are shown in [Table 1](#).

Table 1. Output Resistor Divider Selection

OUTPUT VOLTAGE (V)	R1 (kΩ)	R2 (kΩ)
1	10	15
1.2	10	10
1.5	15	10
1.8	20	10
2.5	31.6	10
3.3	45.3	10
3.3	22.6	4.99
5	73.2	10
5	36.5	4.99

8.3.2 Mix PGOOD, PG_DLY Functions

The PGOOD pin is an open drain output and withstands voltage higher to 17 V. Once feedback voltage of each buck is between 95% (rising) and 105% (falling) of the internal voltage reference and PG_DLY pin voltage overs 1.5 V, the PGOOD pin pull-down is deasserted and the pin floats. It is recommended to use a pullup resistor between the values of 10 kΩ and 100 kΩ to a voltage source that is below 17 V.

The PGOOD pin is pulled low when any feedback voltage of buck is lower than 92.5% (falling), greater than 107.5% (rising) of the nominal internal reference voltage, or PG_DLY pin voltage is below 1.5V (typical). Also, the PGOOD is pulled low, if the input voltage is under-voltage locked up, thermal shutdown is asserted, the EN pin is pulled low or the converter is in soft-start period.

Different combinations of PGOOD, PG_DLY can implement different functions.

8.3.2.1 Programmable PGOOD DELAY

An internal 3-μA pullup current source is connected to PG_DLY pin. The PGOOD delay time can be programmed by connecting a capacitor between PG_DLY pin and ground. The delay time can be calculated as [Equation 2](#).

$$t_{pgood_delay} = \frac{V_{PG_DLY} \times C_1}{I_p}$$

where

- $V_{PG_DLY} = 1.5 \text{ V}$
- $I_p = 3 \text{ μA}$

(2)

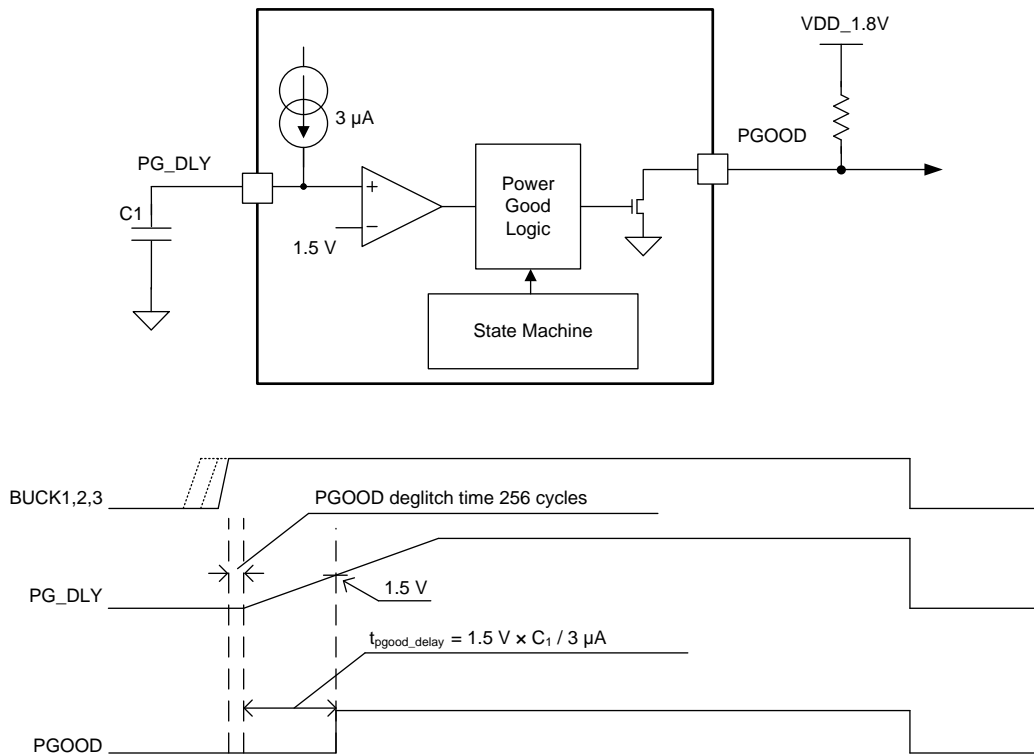
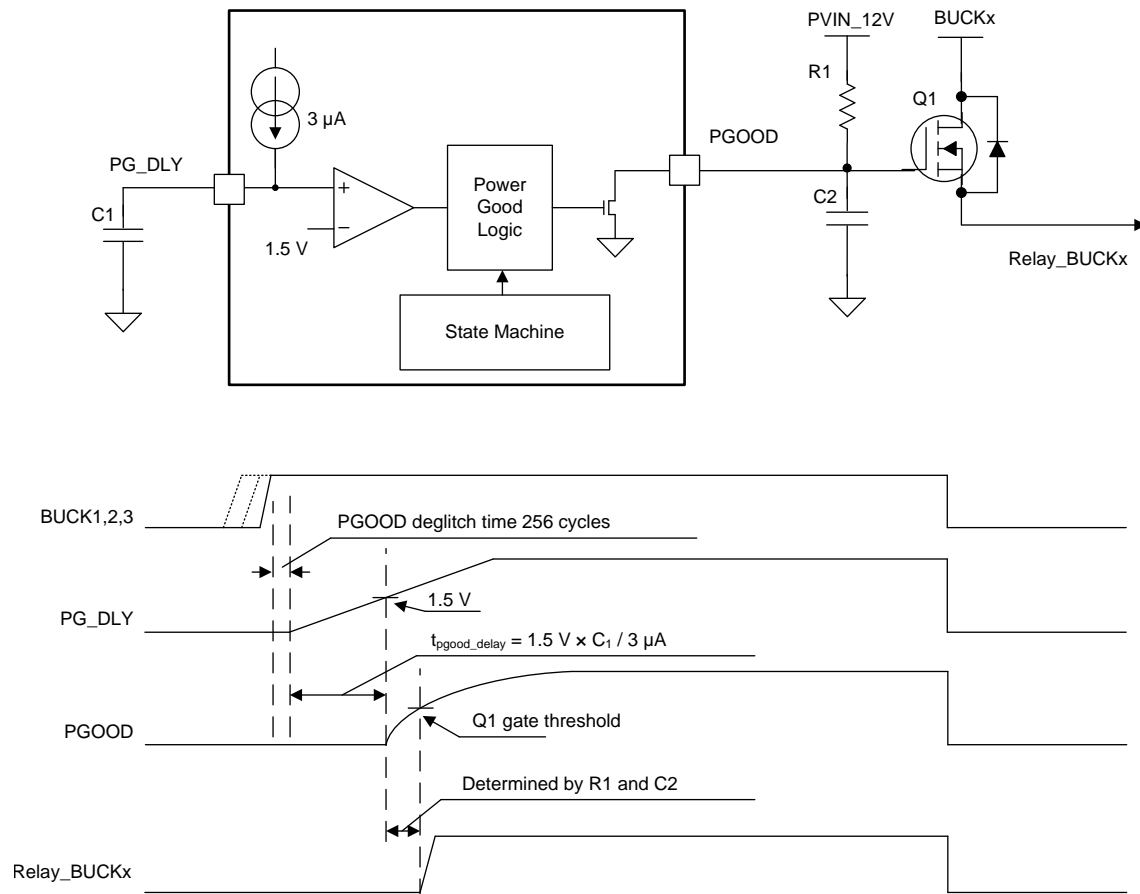

Figure 24. Power Good Delay Timing Diagram

8.3.2.2 Relay Control

PGOOD pin can implement one buck output's relay control through an N-MOSFET, circuit as in [Figure 25](#).

Figure 25. Relay Control Circuit

8.3.3 Enable and Adjusting UVLO

The EN1/2/3 pin provides electrical on/off control of the device. Once the EN1/2/3 pin voltage exceeds the threshold voltage, the device starts operation. If each ENx pin voltage is pulled below the threshold voltage, the regulator stops switching and enters low I_q state.

The EN pin has an internal pullup current source, allowing the user to float the EN pin for enabling the device. If an application requires controlling the EN pin, use open drain or open collector output logic to interface with the pin.

The device implements internal UVLO circuitry on the PVIN1 pin. The device is disabled when the PVIN1 pin voltage falls below the internal VIN UVLO threshold. The internal VIN UVLO threshold has a hysteresis of 600 mV. If an application requires a higher UVLO threshold on the PVIN1, in split-rail applications, then the ENx pin can be configured as shown in [Figure 26](#). When using the external UVLO function it is recommended to set the hysteresis to be greater than 500 mV.

The EN pin has a small pullup current I_p which sets the default state of the pin to enable when no external components are connected. The pullup current is also used to control the voltage hysteresis for the UVLO function since it increases by I_h once the EN pin crosses the enable threshold. The UVLO thresholds can be calculated using [Equation 3](#) and [Equation 4](#).

$$R_1 = \frac{V_{START} \left(\frac{V_{ENFALLING}}{V_{ENRISING}} \right) - V_{STOP}}{I_p \left(1 - \frac{V_{ENFALLING}}{V_{ENRISING}} \right) + I_h} \quad (3)$$

$$R_2 = \frac{R_1 \times V_{ENFALLING}}{V_{STOP} - V_{ENFALLING} + R_1(I_h + I_p)}$$

where

- $I_h = 3.1\mu A$
- $I_p = 2.9\mu A$
- $V_{ENRISING} = 1.15 V$
- $V_{ENFALLING} = 1.12 V$

(4)

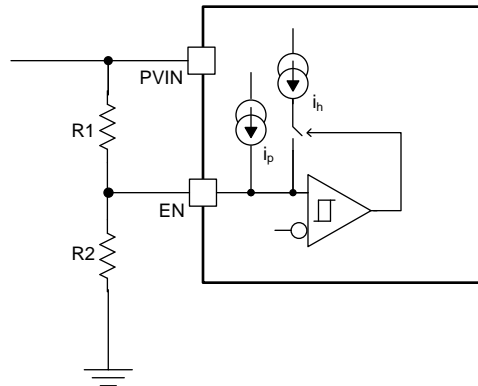

Figure 26. Adjustable PVIN UVLO, PVIN > 4.5 V

8.3.4 Soft-Start Time

TPS65265 has fixed 2.4-ms (typical) soft-start time.

8.3.5 Power-Up Sequencing

TPS65265 features a comprehensive sequencing circuit for the three bucks. If MODE pin was tied to HIGH or tied to GND and at the same time EN1 or EN2 (or both) was (were) pulled high, the automatic power-up and power-down sequence function is active. If MODE pin was left floating, three Buck on/off were separately controlled by three enable pin.

8.3.5.1 External Power Sequencing

The TPS65265 has dedicated enable pin and soft-start pin for each converter. The converter enable pins are biased by a current source that allows for easy sequencing by the addition of an external capacitor. Disabling the converter with an active pulldown transistor on the ENx pin allows for a predictable powerdown timing operation. The Figure 27 shows the timing diagram of a typical buck power-up sequence with connecting a capacitor at ENx pin.

A typical 1.4- μA current is charging ENx pin from input supply. When ENx pin voltage rise to typical 0.4 V, the internal V7V LDO turns on. A 2.9- μA pulldown current is sourcing ENx. After ENx pin voltage reaches to ENx enabling threshold, 3.1- μA hysteresis current sources to the pin to improve noise sensitivity. After soft start time of 2.4 ms (typical), PGOOD monitor is enabled. If all output voltages are in the regulation and after PGOOD delay time, PGOOD is asserted.

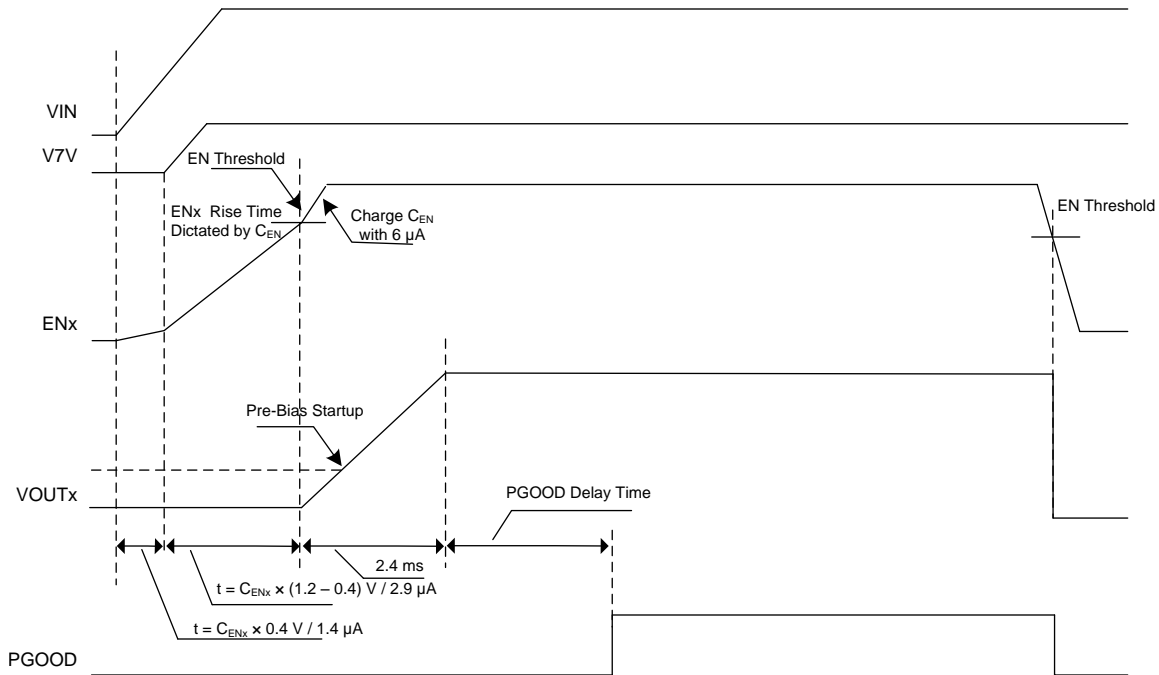
Figure 27. Startup Power Sequence

8.3.5.2 Automatic Power Sequencing

The TPS65265 starts with a predefined power-up and power-down sequence when MODE pin ties HIGH or ties to GND. As shown in [Table 2](#), the sequence is determined by the different combinations of EN1 and EN2 status. EN3 is used to start and stop the converters. [Figure 28](#) shows the power sequencing when MODE ties to GND, EN1, and EN2 are tied to HIGH.

An internal 3-µA pullup current source is connected to SEQ_DLY pin. The interval time between bucks can be programmed by connecting a capacitor between SEQ_DLY pin and ground. The interval time can be calculated with [Equation 5](#).

$$t_1 = \frac{V_1 \times C_1}{i_p} \quad (5)$$

$$t_2 = \frac{(V_2 - V_1) \times C_1}{i_p}$$

where

- $V_1 = 0.75 \text{ V}$
 - $V_2 = 1.5 \text{ V}$
 - $i_p = 3 \text{ µA}$
- (6)

Table 2. Power Sequencing

	MODE	EN1	EN2	EN3	START SEQUENCING	SHUTDOWN SEQUENCING
Automatic Power Sequencing	Connect to GND	High	High	Used to start and stop bucks in sequence	buck1 → buck2 → buck3	buck3 → buck2 → buck1
	Connect to GND	Low	High		buck2 → buck1 → buck3	buck3 → buck1 → buck2
	Connect to GND	High	Low		buck2 → buck3 → buck1	buck1 → buck3 → buck2
	Connect to high or float	High	High		buck1 → buck3 → buck2	buck2 → buck3 → buck1
	Connect to high or float	Low	High		buck3 → buck1 → buck2	buck2 → buck1 → buck3
	Connect to high or float	High	Low		buck3 → buck2 → buck1	buck1 → buck2 → buck3
	Connect to GND	Low	Low	Reserved	Reserved	Reserved
	Connect to high or float	Low	Low	Reserved	Reserved	Reserved
Externally Controlled Sequencing	Floating	Used to start and stop buck1	Used to start and stop buck2	Used to start and stop buck3	x	x

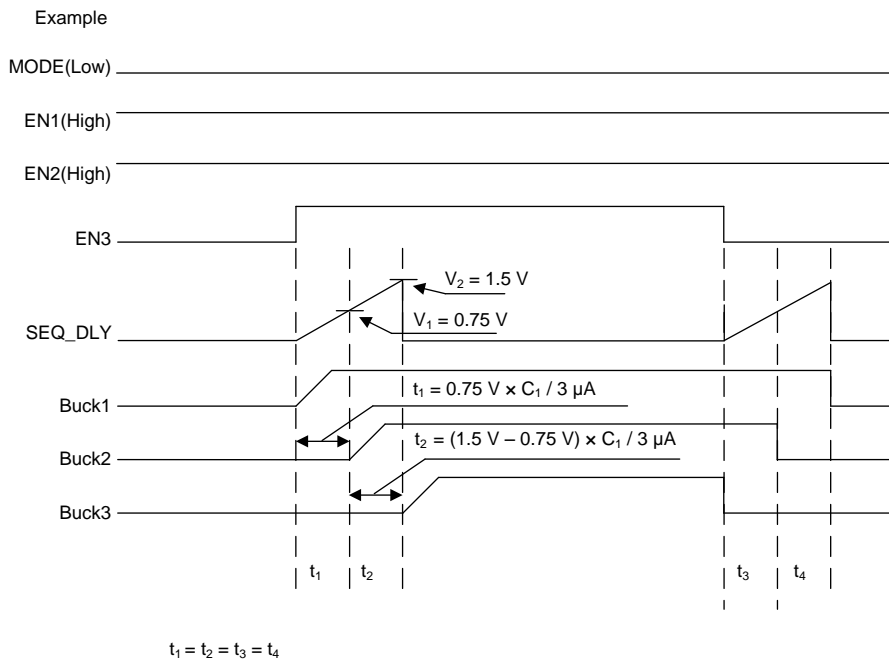
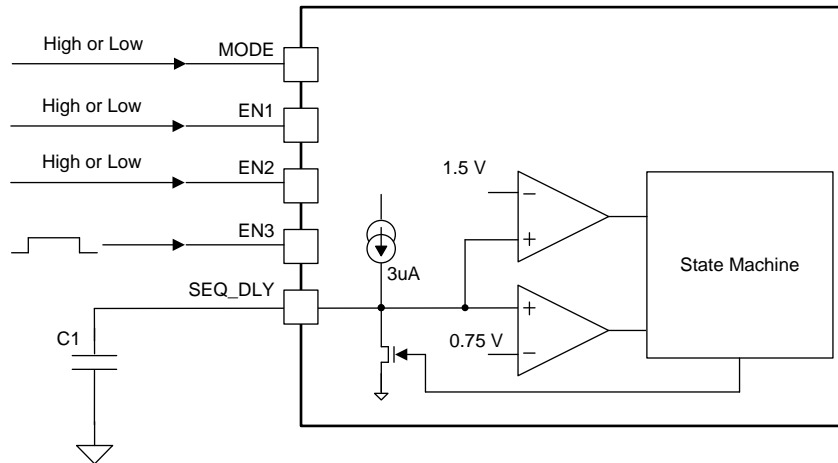
Figure 28. Automatic Power Sequencing

8.3.6 V7V Low Dropout Regulator and Bootstrap

Power for the high-side and low-side MOSFET drivers and most other internal circuitry is derived from the V7V pin. The internal built-in low dropout linear regulator (LDO) supplies 6.1 V (typical) from PVIN1 to V7V. A 1- μF ceramic capacitor should be connected from V7V pin to power ground.

If the input voltage, PVIN1, decreases to UVLO threshold voltage, the UVLO comparator detects V7V pin voltage and forces the converter off.

Each high-side MOSFET driver is biased from the floating bootstrap capacitor CB, shown in [Figure 29](#), which is normally recharged during each cycle through an internal low-side MOSFET or the body diode of low-side MOSFET when the high-side MOSFET turns off. The boot capacitor is charged when the BST pin voltage is less than PVIN and BST-LX voltage is below regulation. The recommended value of this ceramic capacitor is 47 nF. A ceramic capacitor with an X7R or X5R grade dielectric with a voltage rating of 10V or higher is recommended because of the stable characteristics over temperature and voltage. Each low-side MOSFET driver is powered from V7V pin directly.

To improve dropout, the device is designed to operate at 100% duty cycle as long as the BST to LX pin voltage is greater than the BST-LX UVLO threshold, which is typically 2.2 V. When the voltage between BST and LX drops below the BST-LX UVLO threshold, the high-side MOSFET is turned off and the low-side MOSFET is turned on allowing the boot capacitor to be recharged.

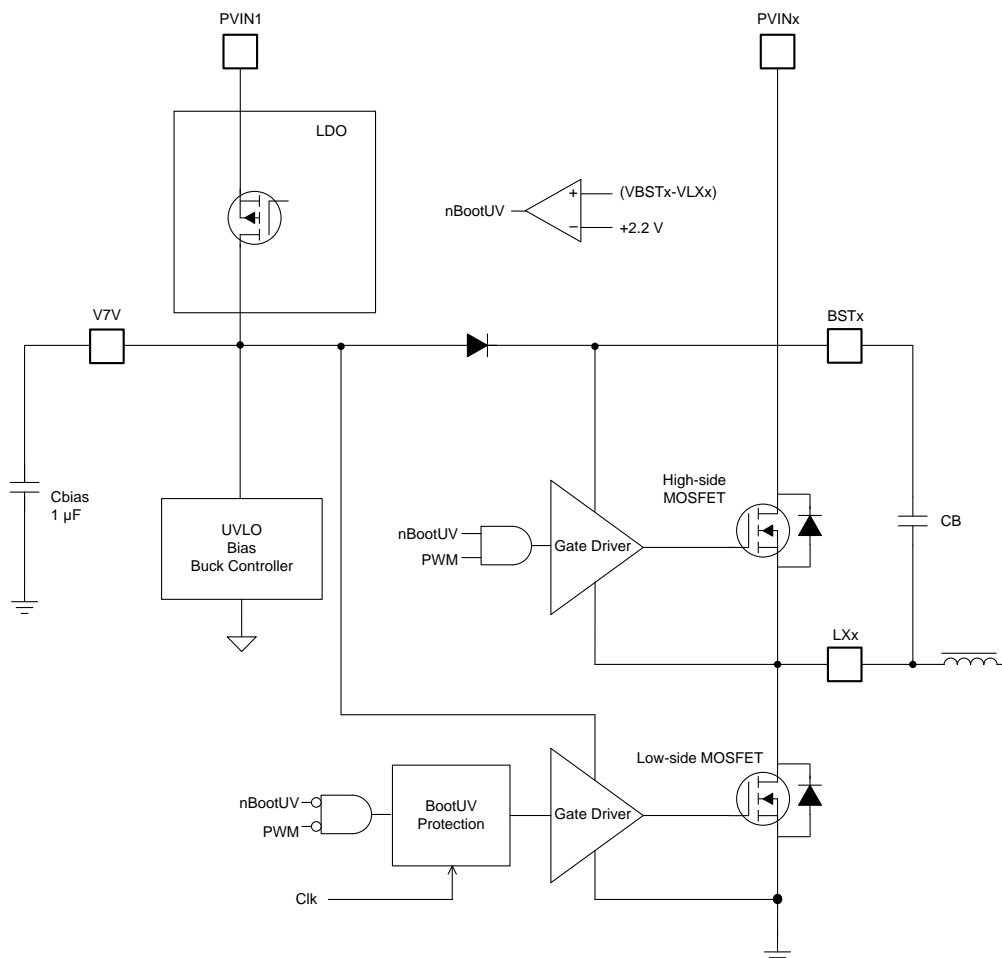

Figure 29. V7V Linear Dropout Regulator and Bootstrap Voltage Diagram

8.3.7 Out of Phase Operation

In order to reduce input ripple current, three switching clocks are 120° out-of-phase. This enables the system having less input current ripple to reduce input capacitors' size, cost, and EMI.

8.3.8 Output Overvoltage Protection (OVP)

The device incorporates an output OVP circuit to minimize output voltage overshoot. When the output is overloaded, the error amplifier compares the actual output voltage to the internal reference voltage. If the FB pin voltage is lower than the internal reference voltage for a considerable time, the output of the error amplifier demands maximum output current. After the condition is removed, the regulator output rises and the error amplifier output transitions to the steady state voltage. In some applications with small output capacitance, the load can respond faster than the error amplifier. This leads to the possibility of an output overshoot. Each buck compares the FB pin voltage to the OVP threshold. If the FB pin voltage is greater than the OVP threshold, the high-side MOSFET is turned off preventing current from flowing to the output and minimizing output overshoot. When the FB voltage drops lower than the OVP threshold, the high-side MOSFET turns on at the next clock cycle.

8.3.9 PSM

The TPS65265 can enter high-efficiency PSM operation at light load current when PSM pin connects to high or leave floating.

When a controller is enabled for PSM operation, the peak inductor current is sensed and compared with 180 mA current typically. Since the integrated current comparator catches the peak inductor current only, the average load current entering PSM varies with the applications and external output filters. In PSM, the sensed peak inductor current is clamped at 180 mA.

When a controller operates in PSM, the inductor current is not allowed to reverse. The reverse current comparator turns off the low-side MOSFET when the inductor current reaches zero, preventing it from reversing and going negative.

Due to the delay in the circuit and current comparator t_{dly} (typical 50 ns at $P_{VIN} = 12$ V), the real peak inductor current threshold to turn off high-side power MOSFET could shift higher depending on inductor inductance and input/output voltages. The threshold of peak inductor current to turn off high-side power MOSFET can be calculated by Equation 7.

$$I_{L_PEAK} = 180 \text{ mA} + \frac{V_{in} - V_{out}}{L} \times t_{dly} \quad (7)$$

Once the charge accumulated on V_{out} capacitor is more than loading need, COMP pin voltage drops to low voltage driven by error amplifier. There is an internal comparator at COMP pin. If comp voltage is lower than 0.35 V, power stage stops switching to save power.

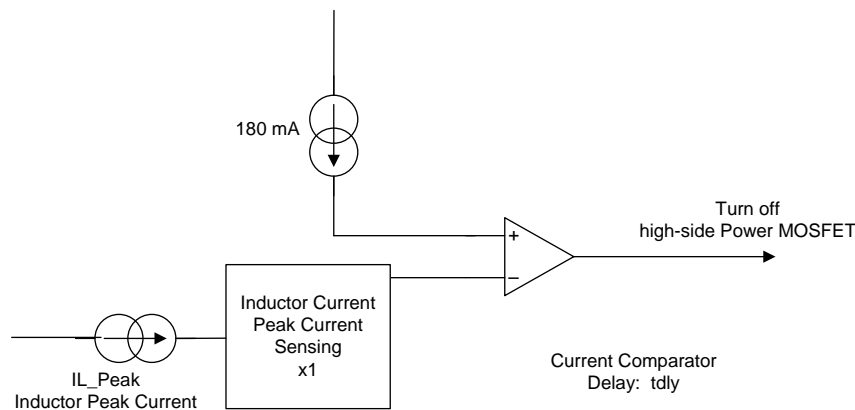

Figure 30. PSM Current Comparator

8.3.10 Slope Compensation

In order to prevent the sub-harmonic oscillations when the device operates at duty cycles greater than 50%, the device adds built-in slope compensation, which is a compensating ramp to the switch current signal.

8.3.11 Overcurrent Protection

The device is protected from over current conditions by cycle-by-cycle current limiting on both the high-side MOSFET and the low-side MOSFET.

8.3.11.1 High-Side MOSFET Overcurrent Protection

The device implements current mode control which uses the COMP pin voltage to control the turn off of the high-side MOSFET and the turn on of the low-side MOSFET on a cycle by cycle basis. Each cycle the switch current and the current reference generated by the COMP pin voltage are compared, when the peak switch current intersects the current reference, the high-side switch is turned off.

8.3.11.2 Low-Side MOSFET Overcurrent Protection

While the low-side MOSFET is turned on, its conduction current is monitored by the internal circuitry. During normal operation the low-side MOSFET sources current to the load. At the end of every clock cycle, the low-side MOSFET sourcing current is compared to the internally set low-side sourcing current limit. If the low-side sourcing current is exceeded, the high-side MOSFET is not turned on and the low-side MOSFET stays on for the next cycle. The high-side MOSFET is turned on again when the low-side current is below the low-side sourcing current limit at the start of a cycle.

The low-side MOSFET may also sink current from the load. If the low-side sinking current limit is exceeded, the low-side MOSFET is turned off immediately for the rest of that clock cycle. In this scenario both MOSFETs are off until the start of the next cycle.

Furthermore, if an output overload condition (as measured by the COMP pin voltage) has lasted for more than the hiccup wait time which is programmed for 256 switching cycles shown in Figure 31, the device will shut down itself and restart after the hiccup time of 8192 cycles. The hiccup mode helps to reduce the device power dissipation under severe overcurrent condition.

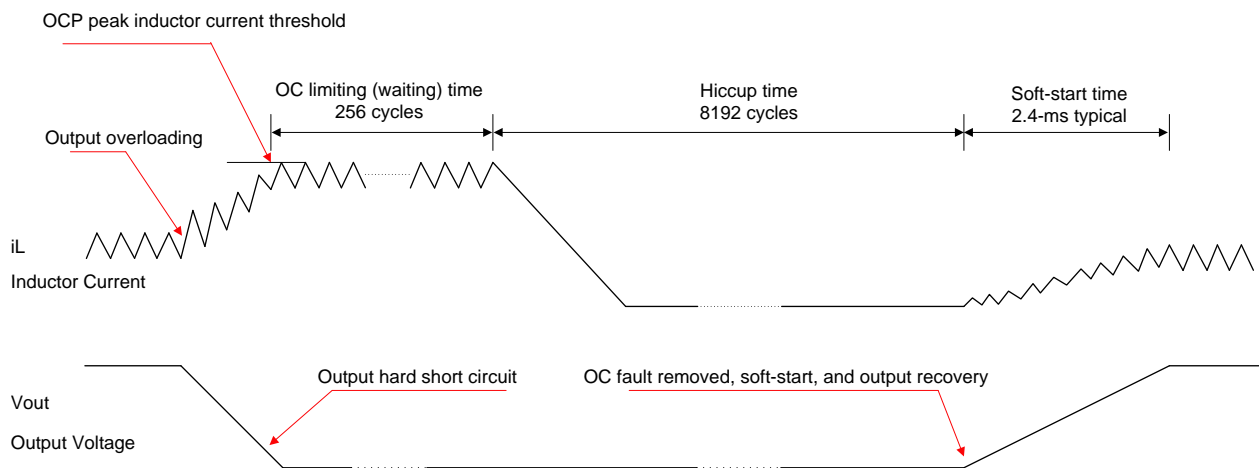

Figure 31. Overcurrent Protection

8.3.12 Adjustable Switching Frequency

The ROSC pin can be used to set the switching frequency by connecting a resistor to GND. The switching frequency of the device is adjustable from 250 kHz to 2.3 MHz.

To determine the switching frequency for a given ROSC resistance, use Equation 8 or the curve in Figure 32. To reduce the solution size one would set the switching frequency as high as possible, but tradeoffs of the supply efficiency and minimum controllable on time should be considered.

$$f_{osc} \text{ (kHz)} = 30975 \times R_{osc} \text{ (k}\Omega\text{)}^{-0.889} \quad (8)$$

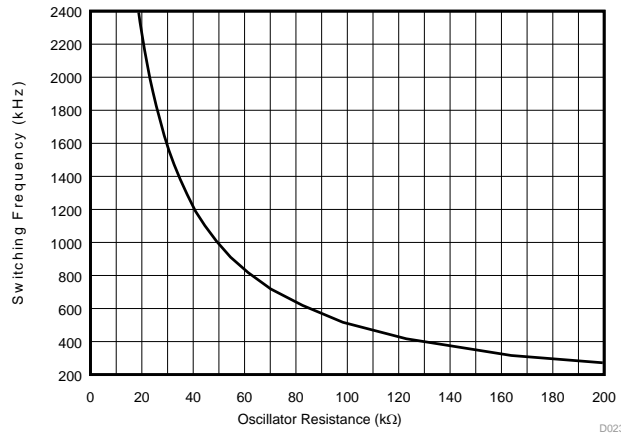

Figure 32. Switching Frequency versus ROSC

When an external clock applies to ROSC pin, the internal phase locked loop (PLL) has been implemented to allow internal clock synchronizing to an external clock between 250 kHz and 2.3 MHz. To implement the clock synchronization feature, connect a square wave clock signal to the ROSC pin with a duty cycle between 20% to 80%. The clock signal amplitude must transition lower than 0.4 V and higher than 2.0 V. The start of the switching cycle is synchronized to the falling edge of ROSC pin.

In applications where both resistor mode and synchronization mode are needed, the device can be configured as shown in Figure 33. Before an external clock is present, the device works in resistor mode and ROSC resistor sets the switching frequency. When an external clock is present, the synchronization mode overrides the resistor mode. The first time the ROSC pin is pulled above the ROSC high threshold (2.0 V), the device switches from the resistor mode to the Synchronization mode and the ROSC pin becomes high impedance as the PLL starts to lock onto the frequency of the external clock. TI does not recommend to switch from the synchronization mode back to the resistor mode because the internal switching frequency drops to 100 kHz first before returning to the switching frequency set by ROSC resistor.

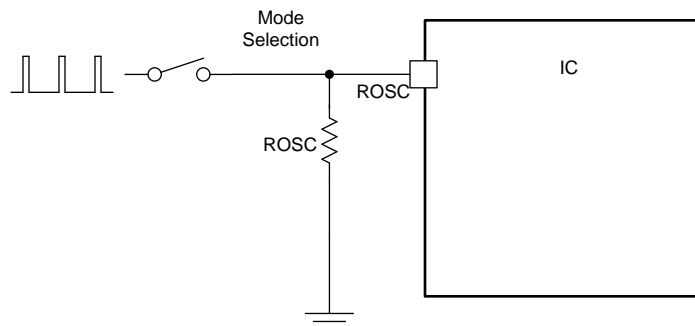

Figure 33. Works With Resistor Mode and Synchronization Mode

8.3.13 Thermal Shutdown

The internal thermal shutdown circuitry forces the device to stop switching if the junction temperature exceeds 160°C typically. The device reinitiates the power-up sequence when the junction temperature drops below 140°C typically.

8.4 Device Functional Modes

8.4.1 Operation With VIN < 4 V (Minimum VIN)

The device operates with input voltages above 4 V. The maximum UVLO voltage is 4 V and will operate at input voltages above 4 V. The typical UVLO voltage is 3.8 V and the device may operate at input voltages above that point. The device also may operate at lower input voltages, the minimum UVLO voltage is 3.6V (rising) and 3V (falling). At input voltages below the UVLO minimum voltage, the devices will not operate.

Device Functional Modes (continued)

8.4.2 Operation With EN Control

The enable rising edge threshold voltage is 1.08 V minimum and 1.22 V maximum. With EN held below that voltage the device is disabled and switching is inhibited. The IC quiescent current is reduced in this state. When input voltage is above the UVLO threshold and the EN voltage is increased above the rising edge threshold, the device becomes active. Switching is enabled, and the internal soft-start sequence is initiated as shown in [Figure 29](#) to [Figure 38](#).

Typical Application (continued)

9.2.1 Design Requirements

This example details the design of triple synchronous step-down converter. A few parameters must be known in order to start the design process. These parameters are typically determined at the system level. For this example, start with the following known parameters shown in [Table 3](#).

Table 3. Design Parameters

PARAMETER	VALUE
Vout1	1.2 V
Iout1	5 A
Vout2	1.5 V
Iout2	3 A
Vout3	1.8 V
Iout3	2 A
Transient response 1-A load step	±5%
Input voltage	12-V normal, 4.5 V to 17 V
Output voltage ripple	±1%
Switching frequency	610 kHz

9.2.2 Detailed Design Procedure

9.2.2.1 Output Inductor Selection

To calculate the value of the output inductor, use [Equation 9](#). LIR is a coefficient that represents the amount of inductor ripple current relative to the maximum output current. The inductor ripple current is filtered by the output capacitor. Therefore, choosing high inductor ripple currents impact the selection of the output capacitor since the output capacitor must have a ripple current rating equal to or greater than the inductor ripple current. In general, the inductor ripple value is at the discretion of the designer; however, LIR is normally from 0.1 to 0.3 for the majority of applications.

$$L = \frac{V_{in\max} - V_{out}}{I_o \times LIR} \times \frac{V_{out}}{V_{in\max} \times f_{sw}} \quad (9)$$

For the output filter inductor, it is important that the RMS current and saturation current ratings not be exceeded. The RMS and peak inductor current can be found from [Equation 11](#) and [Equation 12](#).

$$I_{ripple} = \frac{V_{in\max} - V_{out}}{L} \times \frac{V_{out}}{V_{in\max} \times f_{sw}} \quad (10)$$

$$I_{Lrms} = \sqrt{I_o^2 + \frac{\left(\frac{V_{out} \times (V_{in\max} - V_{out})}{V_{in\max} \times L \times f_{sw}} \right)^2}{12}} \quad (11)$$

$$I_{Lpeak} = I_{out} + \frac{I_{ripple}}{2} \quad (12)$$

The current flowing through the inductor is the inductor ripple current plus the output current. During power up, faults or transient load conditions, the inductor current can increase above the calculated peak inductor current level calculated above. In transient conditions, the inductor current can increase up to the switch current limit of the device. For this reason, the most conservative approach is to specify an inductor with a saturation current rating equal to or greater than the switch current limit rather than the peak inductor current.

9.2.2.2 Output Capacitor Selection

There are three primary considerations for selecting the value of the output capacitor. The output capacitor determines the modulator pole, the output voltage ripple, and how the regulator responds to a large change in load current. The output capacitance needs to be selected based on the most stringent of these three criteria.

The desired response to a large change in the load current is the first criteria. The output capacitor needs to supply the load with current when the regulator cannot. This situation would occur if there are desired hold-up times for the regulator where the output capacitor must hold the output voltage above a certain level for a specified amount of time after the input power is removed. The regulator is also temporarily not able to supply sufficient output current if there is a large, fast increase in the current needs of the load such as a transition from no load to full load. The regulator usually needs two or more clock cycles for the control loop to see the change in load current and output voltage and adjust the duty cycle to react to the change. The output capacitor must be sized to supply the extra current to the load until the control loop responds to the load change. The output capacitance must be large enough to supply the difference in current for 2 clock cycles while only allowing a tolerable amount of droop in the output voltage. Equation 13 shows the minimum output capacitance necessary to accomplish this.

$$C_o = \frac{2 \times \Delta I_{out}}{f_{sw} \times \Delta V_{out}}$$

where

- ΔI_{out} is the change in output current
 - f_{sw} is the regulators switching frequency
 - ΔV_{out} is the allowable change in the output voltage.
- (13)

Equation 14 calculates the minimum output capacitance needed to meet the output voltage ripple specification.

$$C_o > \frac{1}{8 \times f_{sw}} \times \frac{1}{\frac{V_{ripple}}{I_{ripple}}}$$

where

- f_{sw} is the switching frequency.
 - V_{ripple} is the maximum allowable output voltage ripple.
 - I_{ripple} is the inductor ripple current.
- (14)

Equation 15 calculates the maximum ESR an output capacitor can have to meet the output voltage ripple specification.

$$R_{esr} < \frac{V_{ripple}}{I_{ripple}}$$
(15)

Additional capacitance de-ratings for aging, temperature and DC bias should be factored in which increases this minimum value. Capacitors generally have limits to the amount of ripple current they can handle without failing or producing excess heat. An output capacitor that can support the inductor ripple current must be specified. Some capacitor data sheets specify the root mean square (RMS) value of the maximum ripple current. Equation 16 can be used to calculate the RMS ripple current the output capacitor needs to support.

$$I_{Lrms} = \frac{V_{out} \times (V_{inmax} - V_{out})}{\sqrt{12 \times V_{inmax} \times L \times f_{sw}}}$$
(16)

9.2.2.3 Input Capacitor Selection

The TPS65265 requires a high quality ceramic, type X5R or X7R, input decoupling capacitor of at least 10 μ F of effective capacitance on the PVIN input voltage pins. In some applications additional bulk capacitance may also be required for the PVIN input. The effective capacitance includes any DC bias effects. The voltage rating of the input capacitor must be greater than the maximum input voltage. The capacitor must also have a ripple current rating greater than the maximum input current ripple of The TPS65265. The input ripple current can be calculated using Equation 17.

$$I_{inrms} = I_{out} \times \sqrt{\frac{V_{out}}{V_{inmin}} \times \frac{(V_{inmin} - V_{out})}{V_{inmin}}}$$
(17)

The value of a ceramic capacitor varies significantly over temperature and the amount of DC bias applied to the capacitor. The capacitance variations due to temperature can be minimized by selecting a dielectric material that is stable over temperature. X5R and X7R ceramic dielectrics are usually selected for power regulator capacitors because they have a high capacitance to volume ratio and are fairly stable over temperature. The output capacitor must also be selected with the DC bias taken into account. The capacitance value of a capacitor decreases as the DC bias across a capacitor increases. The input capacitance value determines the input ripple voltage of the regulator. The input voltage ripple can be calculated using [Equation 18](#).

$$\Delta V_{in} = \frac{I_{outmax} \times 0.25}{C_{in} \times f_{sw}} \quad (18)$$

9.2.2.4 Loop Compensation

The TPS65265 incorporates a peak current mode control scheme. The error amplifier is a trans-conductance amplifier with a gain of 350 μ S. A typical type II compensation circuit adequately delivers a phase margin between 30 and 90 degrees. C_b adds a high frequency pole to attenuate high frequency noise when needed. To calculate the external compensation components, follow the following steps.

1. Select switching frequency f_{sw} that is appropriate for application depending on L and C sizes, output ripple, EMI, and so forth. Switching frequency between 600 kHz to 1 MHz gives best trade-off between performance and cost. To optimize efficiency, lower switching frequency is desired.
2. Set up crossover frequency, f_c , which is typically between 1/5 and 1/20 of f_{sw} .
3. R_C can be determined by

$$R_C = \frac{2\pi \times f_c \times V_o \times C_o}{G_{m_EA} \times V_{ref} \times G_{m_PS}}$$

where

- G_{m_EA} is the error amplifier gain (350 μ S).
- G_{m_PS} is the power stage voltage to current conversion gain (12 A/V).

4. Calculate C_C by placing a compensation zero at or before the dominant pole ($f_p = \frac{1}{C_o \times R_L \times 2\pi}$).

$$C_c = \frac{R_L \times C_o}{R_C} \quad (20)$$

5. Optional C_b can be used to cancel the zero from the ESR associated with C_o .

$$C_b = \frac{R_{ESR} \times C_o}{R_C} \quad (21)$$

6. Type III compensation can be implemented with the addition of one capacitor, C_1 . This allows for slightly higher loop bandwidths and higher phase margins. If used, C_1 is calculated from [Equation 22](#).

$$C_1 = \frac{1}{2\pi \times R_1 \times f_c} \quad (22)$$

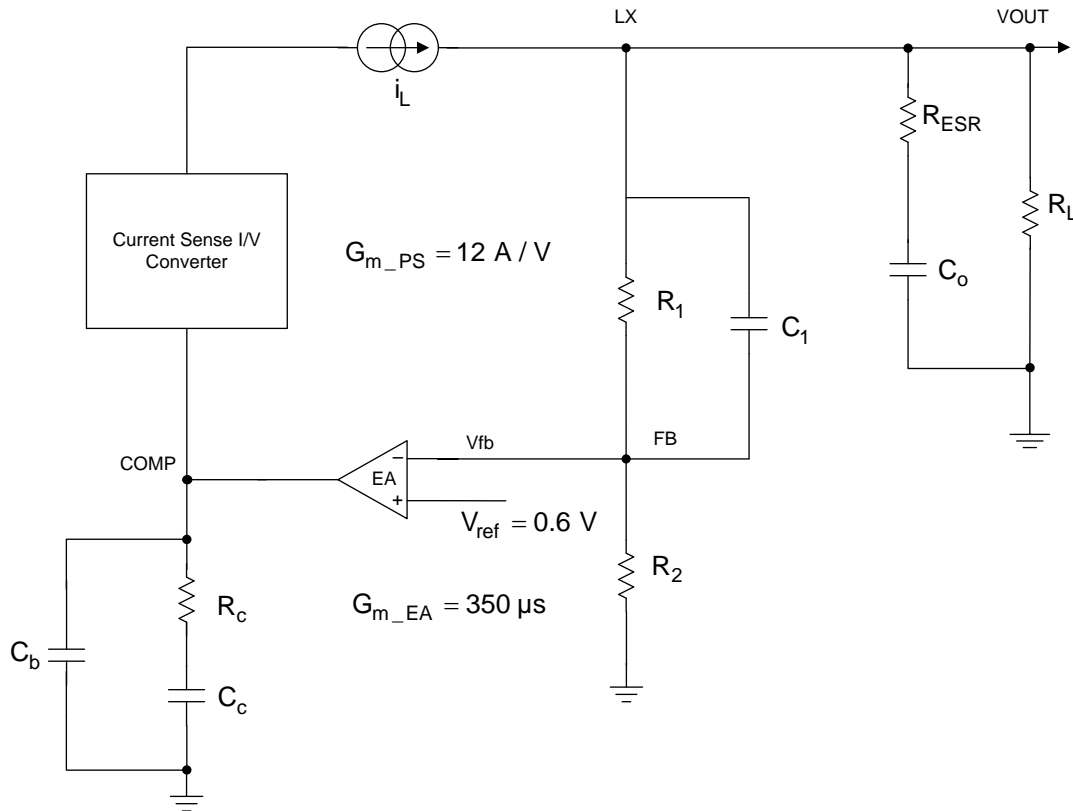

Figure 35. DC-DC Loop Compensation

9.2.3 Application Curves

$T_A = 25^\circ\text{C}$, $V_{IN} = 12\text{ V}$, $V_{OUT1} = 1.2\text{ V}$, $V_{OUT2} = 1.5\text{ V}$, $V_{OUT3} = 1.8\text{ V}$ $F_{SW} = 610\text{ kHz}$ (unless otherwise noted)

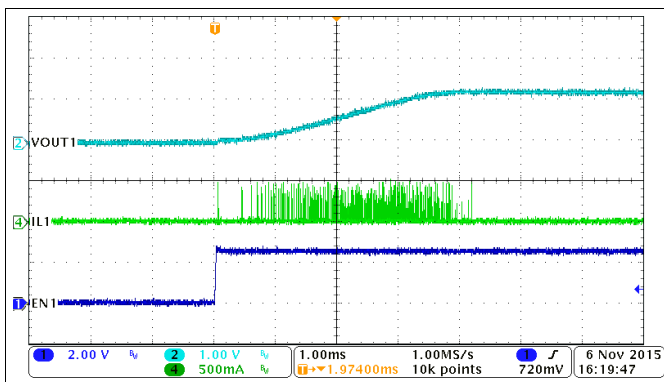

Figure 36. Buck1, PSM Mode, Soft-Start, $i_{out} = 0\text{ A}$

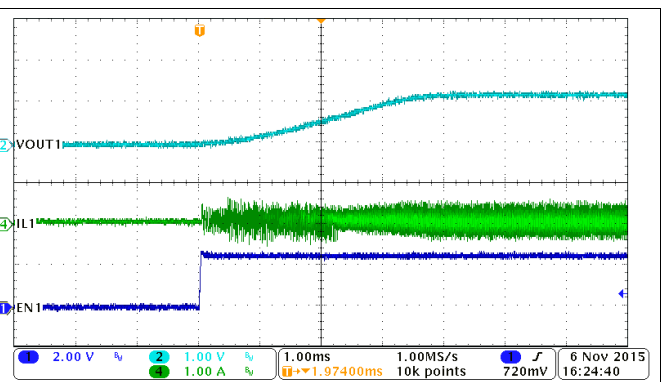

Figure 37. Buck1, FCC Mode, Soft-Start, $i_{out} = 0\text{ A}$

$T_A = 25^\circ\text{C}$, $V_{IN} = 12\text{ V}$, $V_{OUT1} = 1.2\text{ V}$, $V_{OUT2} = 1.5\text{ V}$, $V_{OUT3} = 1.8\text{ V}$ $F_{SW} = 610\text{ kHz}$ (unless otherwise noted)

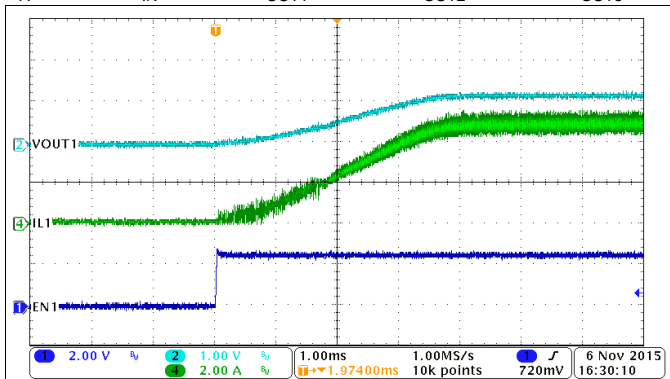

Figure 38. Buck1, PSM Mode, Soft-Start, Iout = 5 A

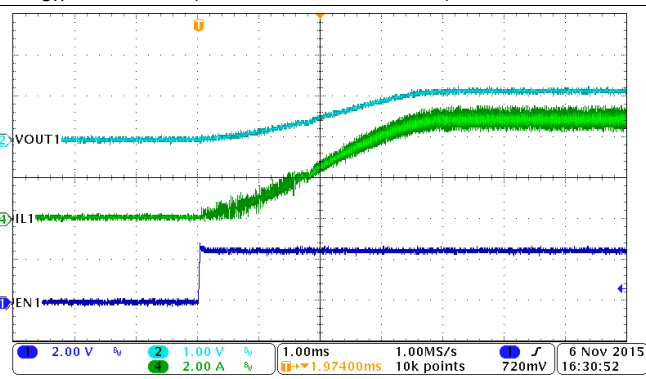

Figure 39. Buck1, FCC Mode, Soft-Start, Iout = 5 A

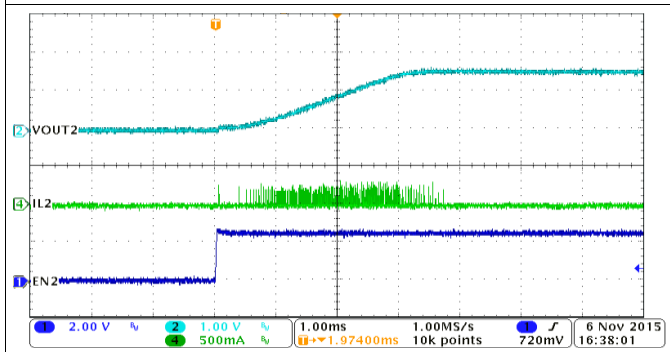

Figure 40. Buck2, PSM Mode, Soft-Start, Iout = 0 A

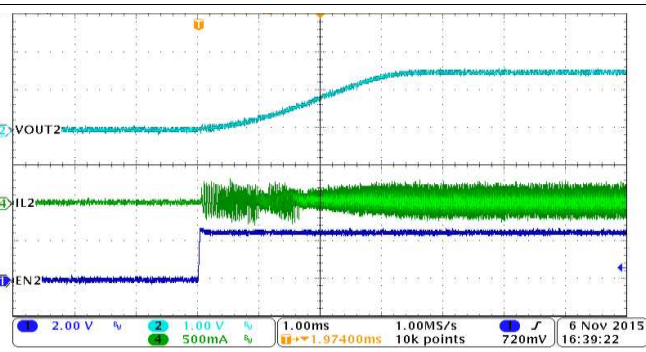

Figure 41. Buck2, FCC Mode, Soft-Start, Iout = 0 A

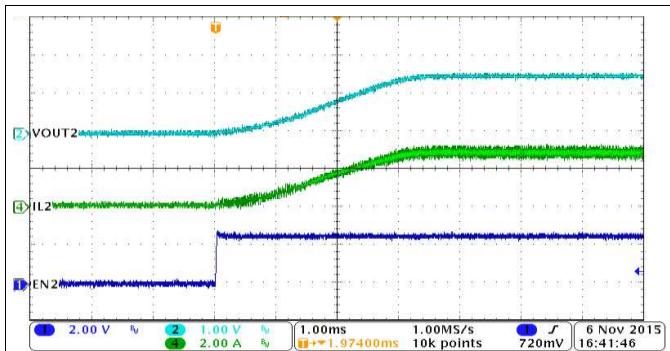

Figure 42. Buck2, PSM Mode, Soft-Start, Iout = 3 A

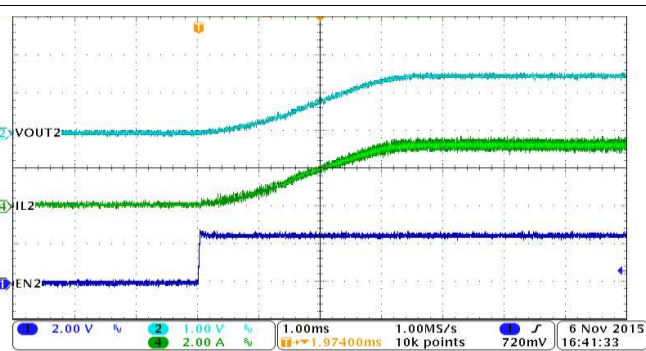

Figure 43. Buck2, FCC Mode, Soft-Start, Iout = 3 A

$T_A = 25^\circ\text{C}$, $V_{IN} = 12\text{ V}$, $V_{OUT1} = 1.2\text{ V}$, $V_{OUT2} = 1.5\text{ V}$, $V_{OUT3} = 1.8\text{ V}$ $F_{SW} = 610\text{ kHz}$ (unless otherwise noted)

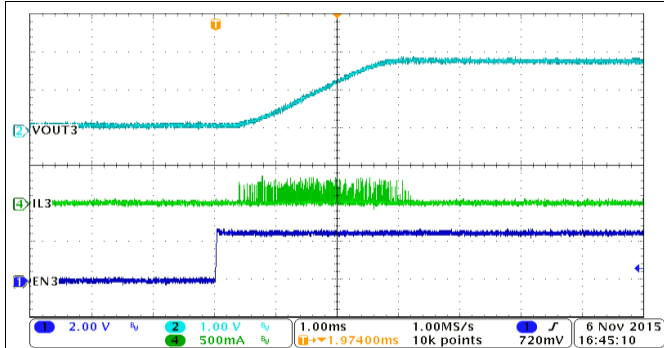

Figure 44. Buck3, PSM Mode, Soft-Start, Iout = 0 A

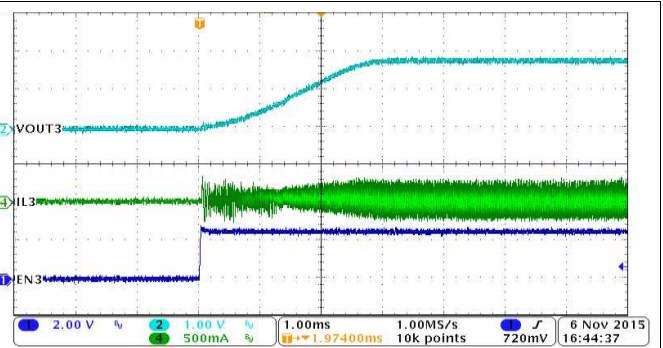

Figure 45. Buck3, FCC Mode, Soft-Start, Iout = 0 A

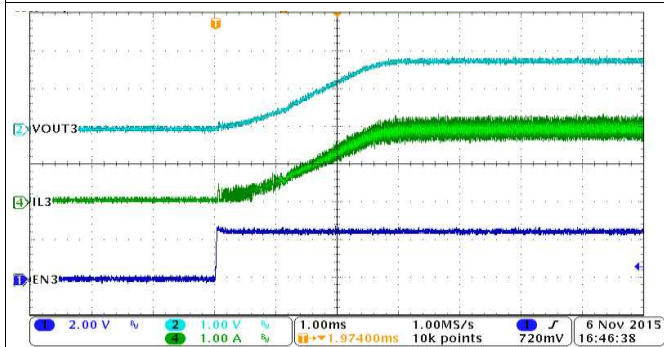

Figure 46. Buck3, PSM Mode, Soft-Start, Iout = 2 A

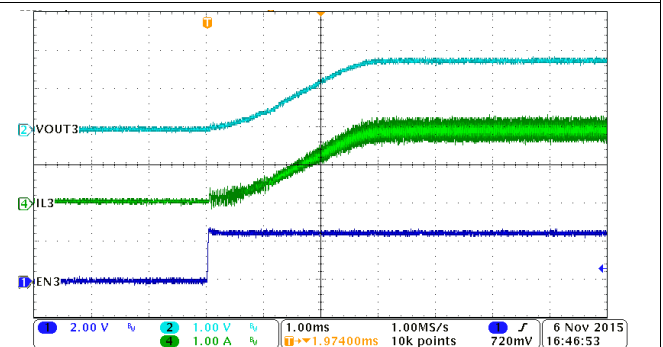

Figure 47. Buck3, FCC Mode, Soft-Start, Iout = 2 A

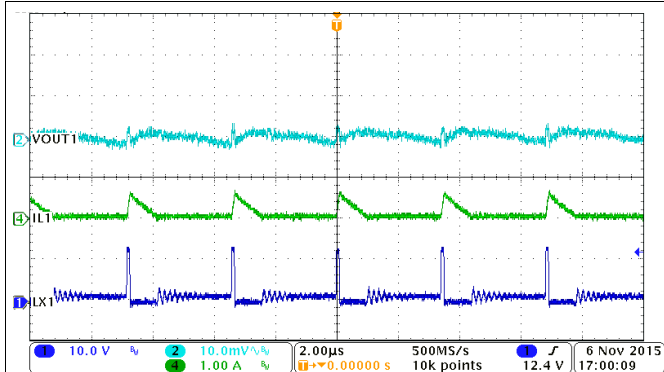

Figure 48. Buck1, PSM Mode, Output Ripple, Light Load

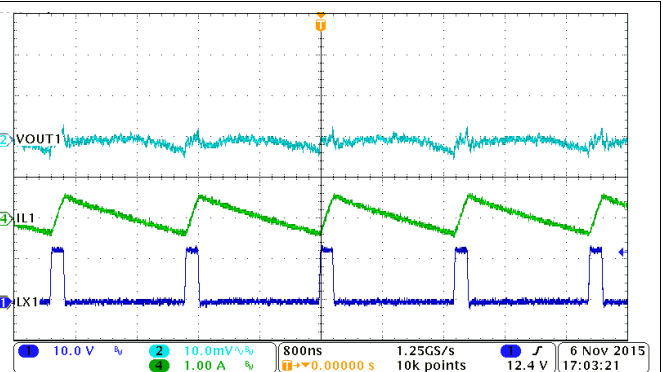

Figure 49. Buck1, FCC Mode, Iout = 0 A

$T_A = 25^\circ\text{C}$, $V_{IN} = 12\text{ V}$, $V_{OUT1} = 1.2\text{ V}$, $V_{OUT2} = 1.5\text{ V}$, $V_{OUT3} = 1.8\text{ V}$ $F_{SW} = 610\text{ kHz}$ (unless otherwise noted)

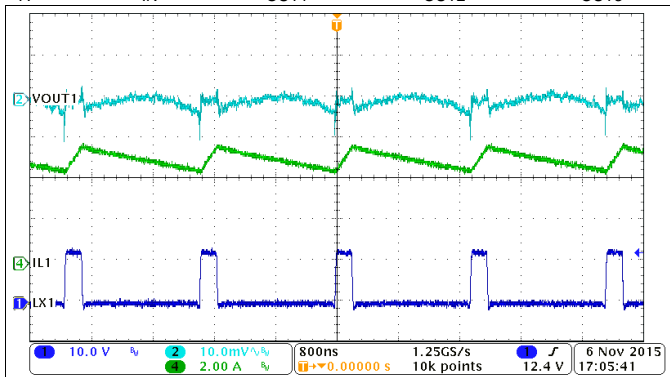

Figure 50. Buck1, Output Ripple, Iout = 5 A

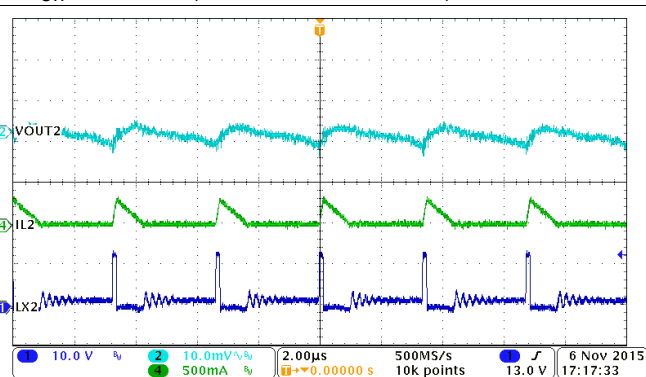

Figure 51. Buck2, PSM Mode, Output Ripple, Light Load

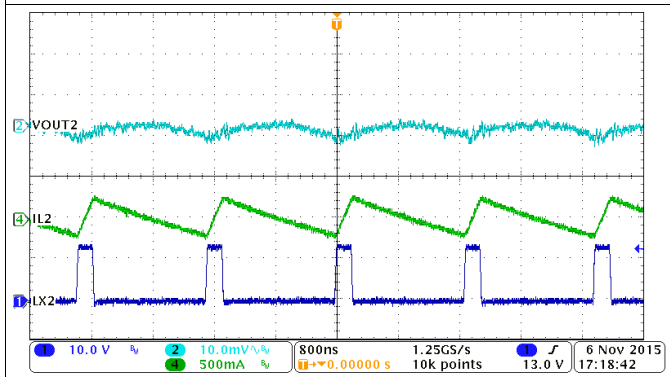

Figure 52. Buck2, FCC Mode, Iout = 0 A

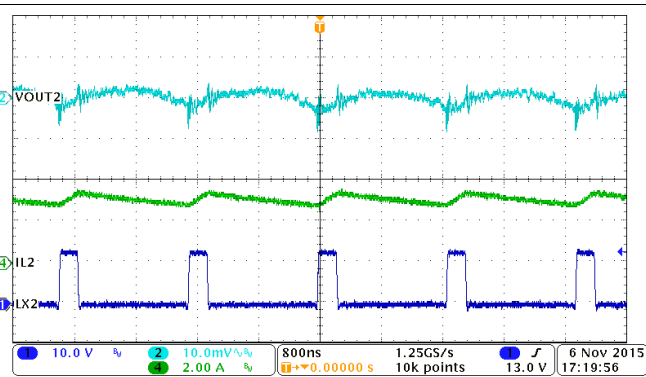

Figure 53. Buck2, Output Ripple, Iout = 3 A

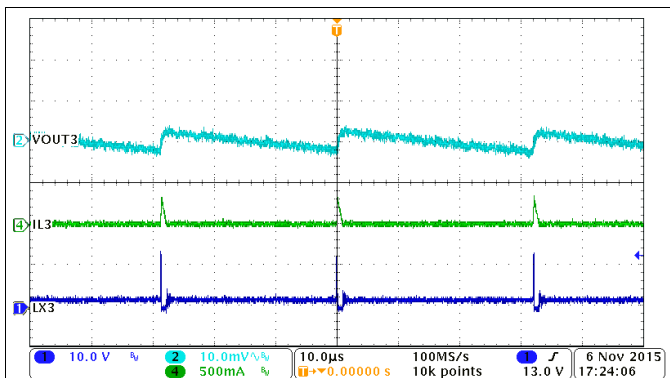

Figure 54. Buck3, PSM Mode, Output Ripple, Light Load

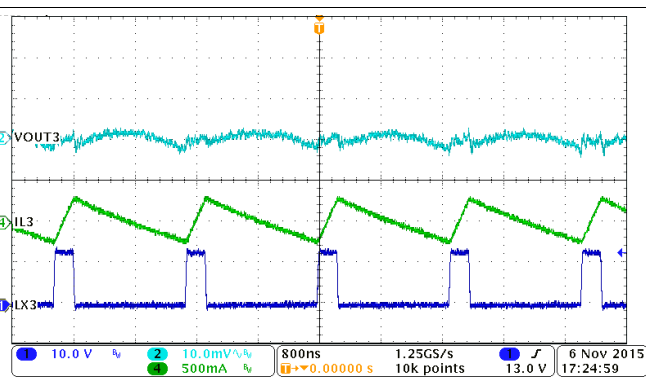

Figure 55. Buck3, FCC Mode, Iout = 0 A

$T_A = 25^\circ\text{C}$, $V_{IN} = 12\text{ V}$, $V_{OUT1} = 1.2\text{ V}$, $V_{OUT2} = 1.5\text{ V}$, $V_{OUT3} = 1.8\text{ V}$ $F_{SW} = 610\text{ kHz}$ (unless otherwise noted)

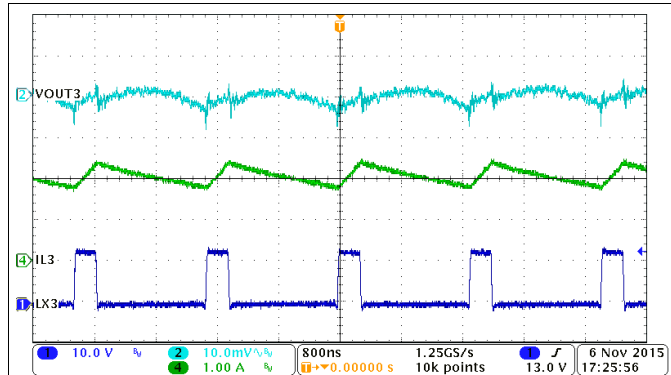

Figure 56. Buck3, Output Ripple, $I_{out} = 2\text{ A}$

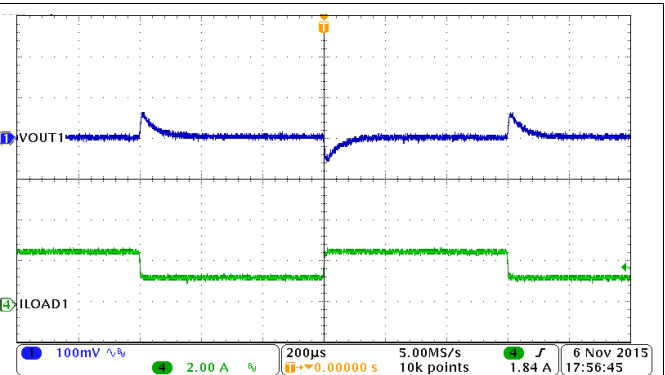

Figure 57. Buck1, Load Transient, 1.25 A to 2.5 A, SR 0.25 A/µs

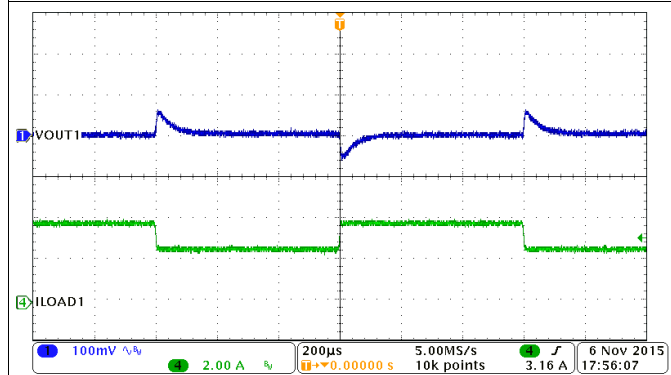

Figure 58. Buck1, Load Transient, 2.5 A to 3.75 A, SR 0.25 A/µs

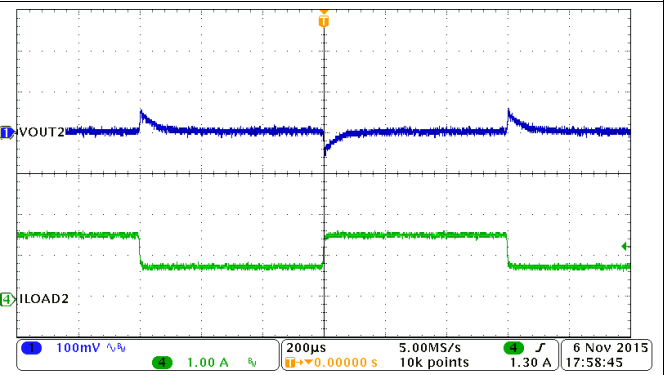

Figure 59. Buck2, Load Transient, 0.75 A to 1.5 A, SR 0.25 A/µs

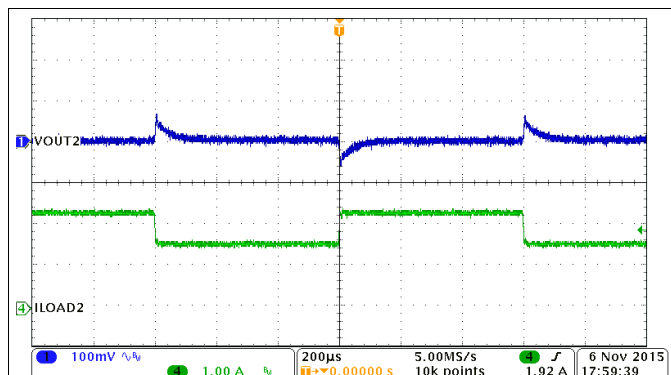

Figure 60. Buck2, Load Transient, 1.5 A to 2.25 A, SR 0.25 A/µs

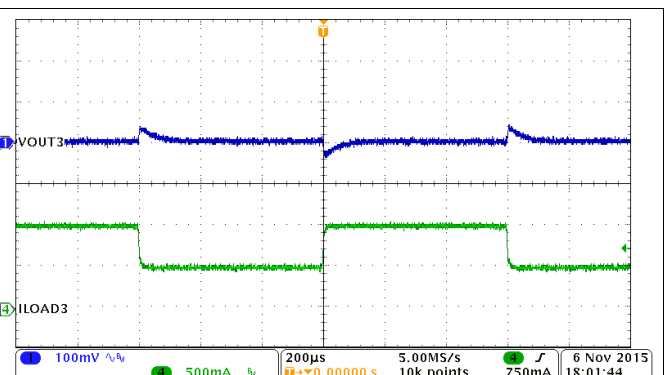

Figure 61. Buck3, Load Transient, 0.5 A to 1 A, SR 0.25 A/µs

$T_A = 25^\circ\text{C}$, $V_{IN} = 12\text{ V}$, $V_{OUT1} = 1.2\text{ V}$, $V_{OUT2} = 1.5\text{ V}$, $V_{OUT3} = 1.8\text{ V}$ $F_{SW} = 610\text{ kHz}$ (unless otherwise noted)

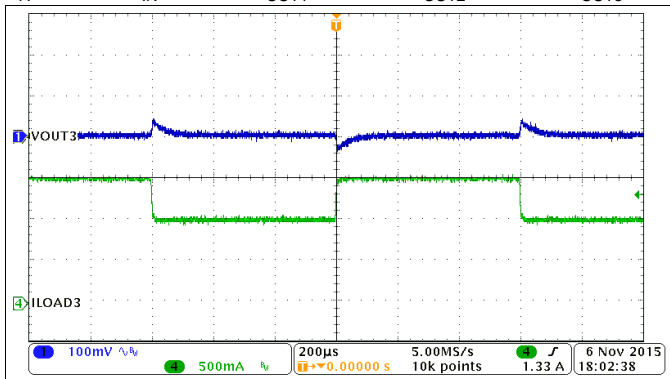

Figure 62. Buck3, Load Transient, 1 A to 1.5 A, SR 0.25 A/µs

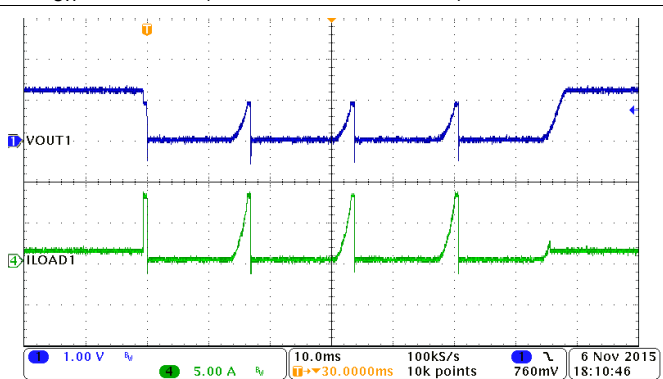

Figure 63. Buck1, Hiccup and Recovery

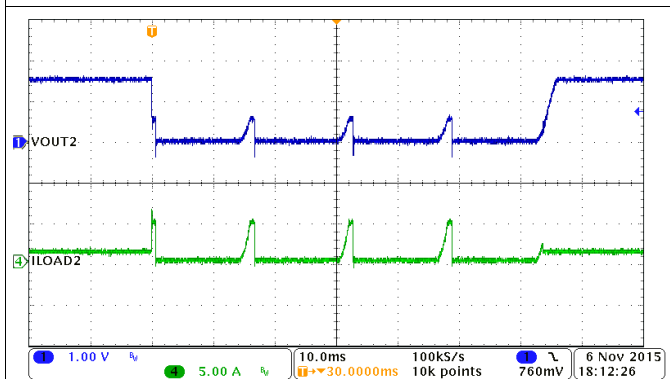

Figure 64. Buck2, Hiccup and Recovery

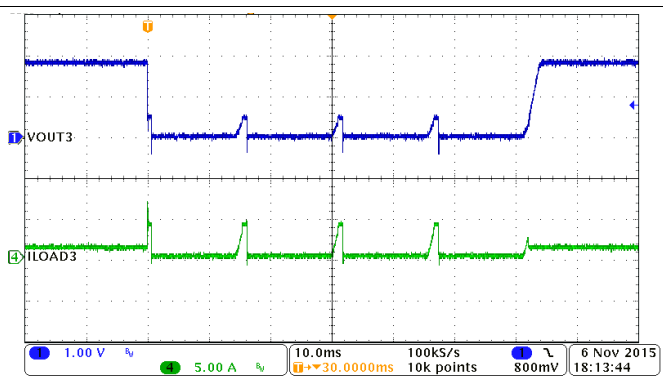

Figure 65. Buck3, Hiccup and Recovery

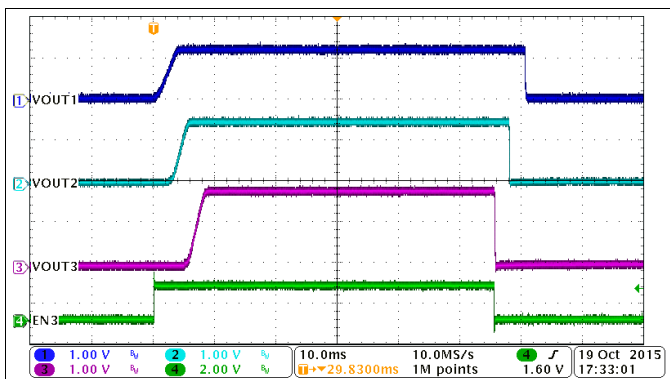

Figure 66. Automatic Power Sequencing, MODE = LOW, EN1 = HIGH, EN2 = HIGH

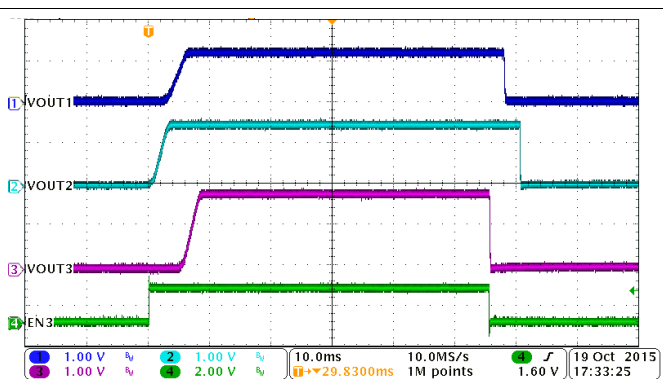

Figure 67. Automatic Power Sequencing, MODE = LOW, EN1 = LOW, EN2 = HIGH

$T_A = 25^\circ\text{C}$, $V_{IN} = 12\text{ V}$, $V_{OUT1} = 1.2\text{ V}$, $V_{OUT2} = 1.5\text{ V}$, $V_{OUT3} = 1.8\text{ V}$ $F_{SW} = 610\text{ kHz}$ (unless otherwise noted)

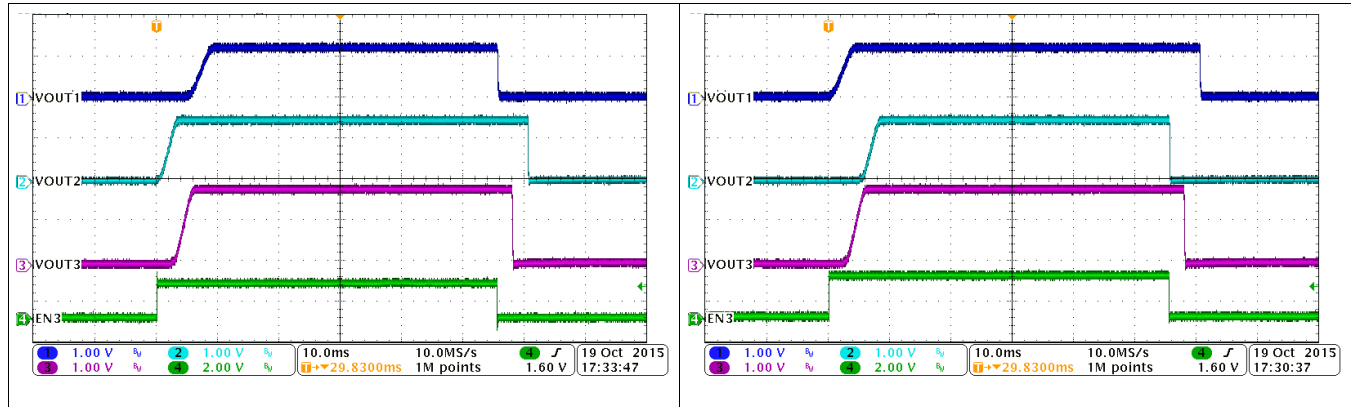

Figure 68. Automatic Power Sequencing, MODE = LOW, EN1 = HIGH, EN2 = LOW

Figure 69. Automatic Power Sequencing, MODE = HIGH, EN1 = HIGH, EN2 = HIGH

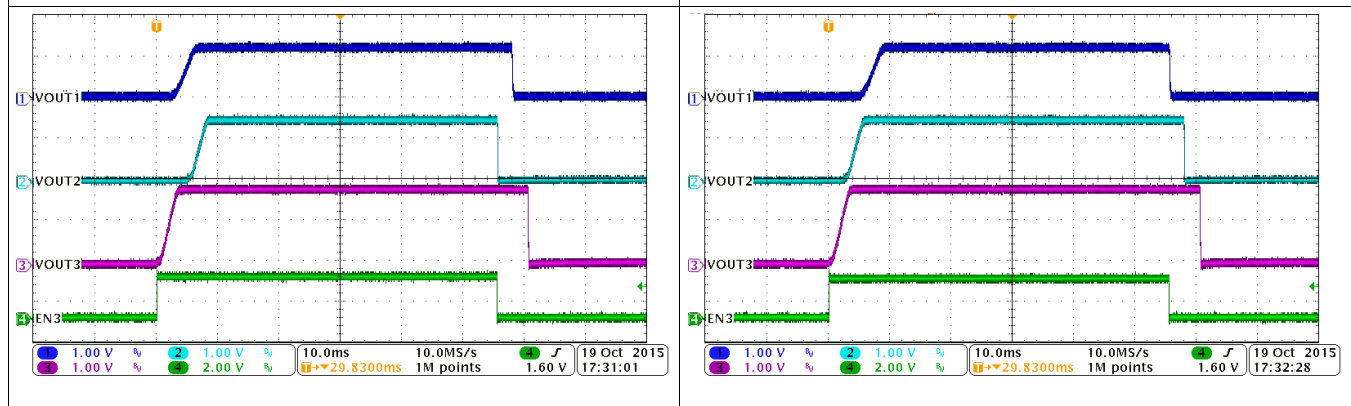

Figure 70. Automatic Power Sequencing, MODE = HIGH, EN1 = LOW, EN2 = HIGH

Figure 71. Automatic Power Sequencing, MODE = HIGH, EN1 = HIGH, EN2 = LOW

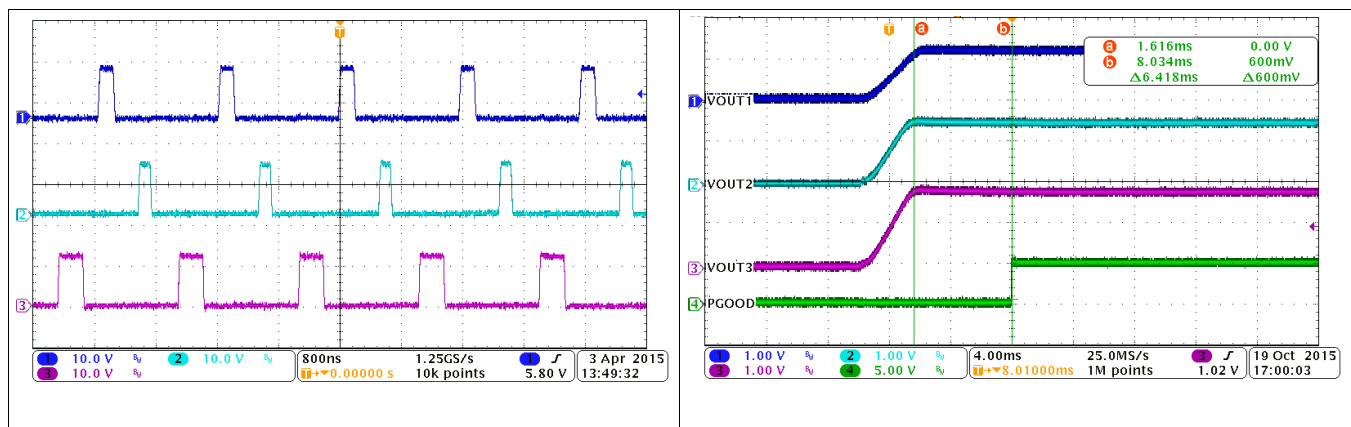

Figure 72. 120° Out of Phase for Buck1, Buck2, Buck3

Figure 73. PGOOD Delay, $C_{PG_DLY} = 10\text{ nF}$

10 Power Supply Recommendations

The device is designed to operate from an input voltage supply range between 4.5 V and 17 V. This input power supply should be well regulated. If the input supply is located more than a few inches from the TPS65265 converter additional bulk capacitance may be required in addition to the ceramic bypass capacitors. An electrolytic capacitor with a value of 47 μ F is a typical choice.

11 Layout

11.1 Layout Guidelines

The TPS65265 can be layout on 2-layer PCB, illustrated [Figure 74](#).

Layout is a critical portion of good power supply design. See [Figure 74](#) for a PCB layout example. The top contains the main power traces for PVIN, VOUT, and LX. Also on the top layer are connections for the remaining pins of the TPS65265 and a large top side area filled with ground. The top layer ground area should be connected to the bottom layer ground using vias at the input bypass capacitor, the output filter capacitor and directly under the TPS65265 device to provide a thermal path from the exposed thermal pad land to ground. The bottom layer acts as ground plane connecting analog ground and power ground.

For operation at full rated load, the top-side ground area together with the bottom side ground plane must provide adequate heat dissipating area. There are several signals paths that conduct fast changing currents or voltages that can interact with stray inductance or parasitic capacitance to generate noise or degrade the power supplies performance. To help eliminate these problems, the PVIN pin should be bypassed to ground with a low-ESR ceramic bypass capacitor with X5R or X7R dielectric. Take care to minimize the loop area formed by the bypass capacitor connections, the PVIN pins, and the ground connections. The PVIN pin must also be bypassed to ground using a low-ESR ceramic capacitor with X5R or X7R dielectric.

Because the LX connection is the switching node, the output inductor should be located close to the LX pins, and the area of the PCB conductor minimized to prevent excessive capacitive coupling. The output filter capacitor ground should use the same power ground trace as the PVIN input bypass capacitor. Try to minimize this conductor length while maintaining adequate width. The small signal components should be grounded to the analog ground path.

The FB and COMP pins are sensitive to noise so the resistors and capacitors should be located as close as possible to the IC and routed with minimal lengths of trace. The additional external components can be placed approximately as shown.

11.2 Layout Example

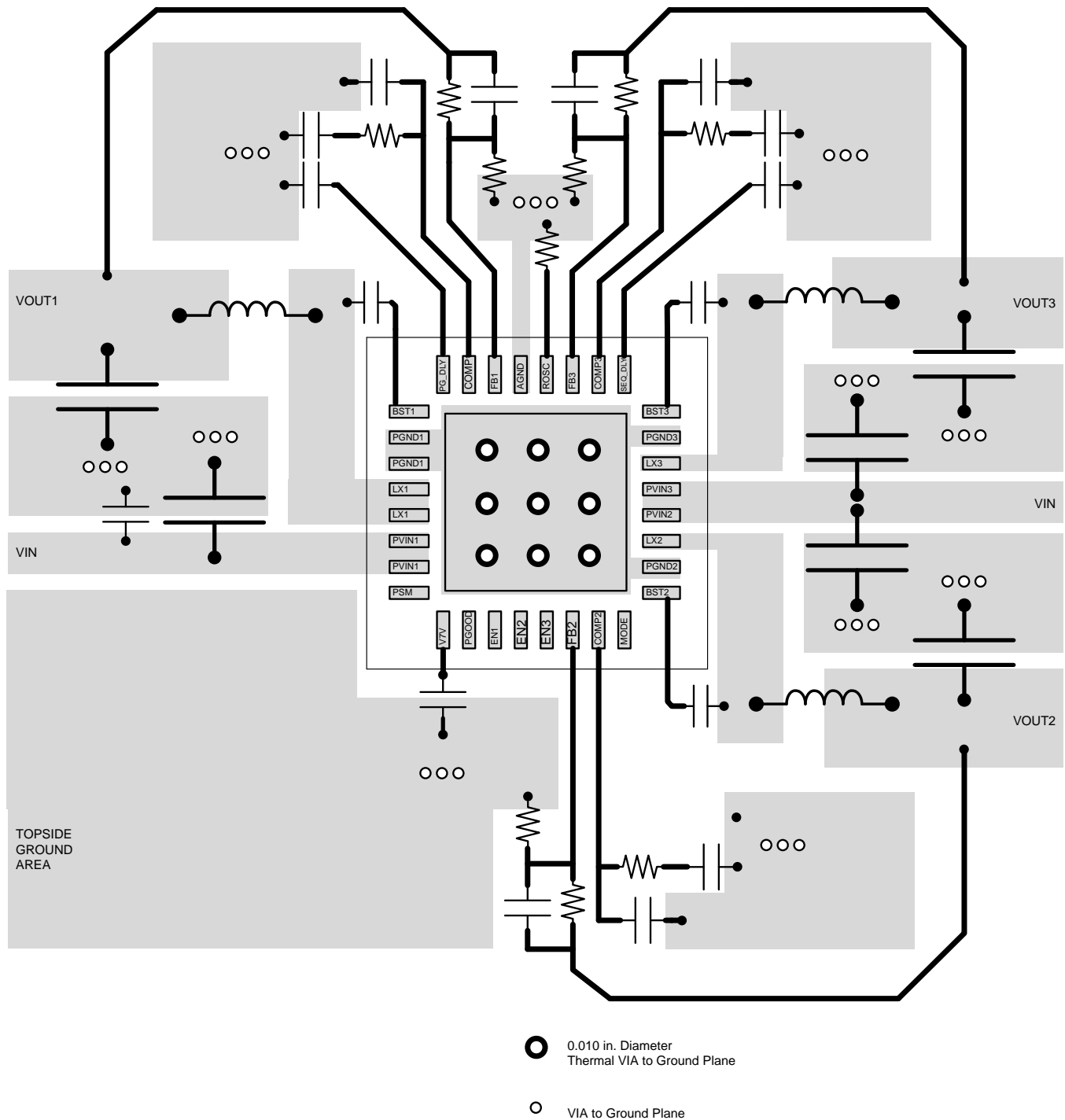

Figure 74. PCB Layout

12 器件和文档支持

12.1 社区资源

The following links connect to TI community resources. Linked contents are provided "AS IS" by the respective contributors. They do not constitute TI specifications and do not necessarily reflect TI's views; see TI's [Terms of Use](#).

TI E2E™ Online Community *TI's Engineer-to-Engineer (E2E) Community*. Created to foster collaboration among engineers. At e2e.ti.com, you can ask questions, share knowledge, explore ideas and help solve problems with fellow engineers.

Design Support *TI's Design Support* Quickly find helpful E2E forums along with design support tools and contact information for technical support.

12.2 商标

E2E is a trademark of Texas Instruments.
All other trademarks are the property of their respective owners.

12.3 静电放电警告



这些装置包含有限的内置 ESD 保护。存储或装卸时，应将导线一起截短或将装置放置于导电泡棉中，以防止 MOS 门极遭受静电损伤。

12.4 Glossary

[SLYZ022](#) — *TI Glossary*.

This glossary lists and explains terms, acronyms, and definitions.

13 机械、封装和可订购信息

以下页中包括机械、封装和可订购信息。这些信息是针对指定器件可提供的最新数据。这些数据会在无通知且不对本文档进行修订的情况下发生改变。欲获得该数据表的浏览器版本，请查阅左侧的导航栏。

重要声明

德州仪器(TI)及其下属子公司有权根据 JESD46 最新标准,对所提供的产品和服务进行更正、修改、增强、改进或其它更改,并有权根据 JESD48 最新标准中止提供任何产品和服务。客户在下订单前应获取最新的相关信息,并验证这些信息是否完整且是最新的。所有产品的销售都遵循在订单确认时所提供的TI 销售条款与条件。

TI 保证其所销售的组件的性能符合产品销售时 TI 半导体产品销售条件与条款的适用规范。仅在 TI 保证的范围内,且 TI 认为有必要时才会使用测试或其它质量控制技术。除非适用法律做出了硬性规定,否则没有必要对每种组件的所有参数进行测试。

TI 对应用帮助或客户产品设计不承担任何义务。客户应对其使用 TI 组件的产品和应用自行负责。为尽量减小与客户产品和应用相关的风险,客户应提供充分的设计与操作安全措施。

TI 不对任何 TI 专利权、版权、屏蔽作品权或其它与使用了 TI 组件或服务的组合设备、机器或流程相关的 TI 知识产权中授予的直接或隐含权限作出任何保证或解释。TI 所发布的与第三方产品或服务有关的信息,不能构成从 TI 获得使用这些产品或服务的许可、授权、或认可。使用此类信息可能需要获得第三方的专利权或其它知识产权方面的许可,或是 TI 的专利权或其它知识产权方面的许可。

对于 TI 的产品手册或数据表中 TI 信息的重要部分,仅在没有对内容进行任何篡改且带有相关授权、条件、限制和声明的情况下才允许进行复制。TI 对此类篡改过的文件不承担任何责任或义务。复制第三方的信息可能需要服从额外的限制条件。

在转售 TI 组件或服务时,如果对该组件或服务参数的陈述与 TI 标明的参数相比存在差异或虚假成分,则会失去相关 TI 组件或服务的所有明示或暗示授权,且这是不正当的、欺诈性商业行为。TI 对任何此类虚假陈述均不承担任何责任或义务。

客户认可并同意,尽管任何应用相关信息或支持仍可能由 TI 提供,但他们将独立负责满足与其产品及其在应用中使用的 TI 产品相关的所有法律、法规和安全相关要求。客户声明并同意,他们具备制定与实施安全措施所需的全部专业技术和知识,可预见故障的危险后果、监测故障及其后果、降低有可能造成人身伤害的故障的发生机率并采取适当的补救措施。客户将全额赔偿因在此类安全关键应用中使用任何 TI 组件而对 TI 及其代理造成的任何损失。

在某些场合中,为了推进安全相关应用有可能对 TI 组件进行特别的促销。TI 的目标是利用此类组件帮助客户设计和创立其特有的可满足适用的功能安全性标准和要求的终端产品解决方案。尽管如此,此类组件仍然服从这些条款。

TI 组件未获得用于 FDA Class III (或类似的生命攸关医疗设备)的授权许可,除非各方授权官员已经达成了专门管控此类使用的特别协议。



只有那些 TI 特别注明属于军用等级或“增强型塑料”的 TI 组件才是设计或专门用于军事/航空应用或环境的。购买者认可并同意,对并非指定面向军事或航空航天用途的 TI 组件进行军事或航空航天方面的应用,其风险由客户单独承担,并且由客户独立负责满足与此类使用相关的所有法律和法规要求。

TI 已明确指定符合 ISO/TS16949 要求的产品,这些产品主要用于汽车。在任何情况下,因使用非指定产品而无法达到 ISO/TS16949 要求, TI 不承担任何责任。

	产品		应用
数字音频	www.ti.com.cn/audio	通信与电信	www.ti.com.cn/telecom
放大器和线性器件	www.ti.com.cn/amplifiers	计算机及周边	www.ti.com.cn/computer
数据转换器	www.ti.com.cn/dataconverters	消费电子	www.ti.com.cn/consumer-apps
DLP® 产品	www.dlp.com	能源	www.ti.com.cn/energy
DSP - 数字信号处理器	www.ti.com.cn/dsp	工业应用	www.ti.com.cn/industrial
时钟和计时器	www.ti.com.cn/clockandtimers	医疗电子	www.ti.com.cn/medical
接口	www.ti.com.cn/interface	安防应用	www.ti.com.cn/security
逻辑	www.ti.com.cn/logic	汽车电子	www.ti.com.cn/automotive
电源管理	www.ti.com.cn/power	视频和影像	www.ti.com.cn/video
微控制器 (MCU)	www.ti.com.cn/microcontrollers		
RFID 系统	www.ti.com.cn/rfidsys		
OMAP应用处理器	www.ti.com/omap		
无线连通性	www.ti.com.cn/wirelessconnectivity	德州仪器在线技术支持社区	www.deyisupport.com

邮寄地址: 上海市浦东新区世纪大道1568号, 中建大厦32楼邮政编码: 200122
Copyright © 2016, 德州仪器半导体技术(上海)有限公司

PACKAGING INFORMATION

Orderable Device	Status (1)	Package Type	Package Drawing	Pins	Package Qty	Eco Plan (2)	Lead finish/ Ball material (6)	MSL Peak Temp (3)	Op Temp (°C)	Device Marking (4/5)	Samples
TPS65265RHBR	ACTIVE	VQFN	RHB	32	3000	RoHS & Green	NIPDAU	Level-2-260C-1 YEAR	-40 to 85	TPS 65265	
TPS65265RHBT	ACTIVE	VQFN	RHB	32	250	RoHS & Green	NIPDAU	Level-2-260C-1 YEAR	-40 to 85	TPS 65265	

(1) The marketing status values are defined as follows:

ACTIVE: Product device recommended for new designs.

LIFEBUY: TI has announced that the device will be discontinued, and a lifetime-buy period is in effect.

NRND: Not recommended for new designs. Device is in production to support existing customers, but TI does not recommend using this part in a new design.

PREVIEW: Device has been announced but is not in production. Samples may or may not be available.

OBSOLETE: TI has discontinued the production of the device.

(2) **RoHS:** TI defines "RoHS" to mean semiconductor products that are compliant with the current EU RoHS requirements for all 10 RoHS substances, including the requirement that RoHS substance do not exceed 0.1% by weight in homogeneous materials. Where designed to be soldered at high temperatures, "RoHS" products are suitable for use in specified lead-free processes. TI may reference these types of products as "Pb-Free".

RoHS Exempt: TI defines "RoHS Exempt" to mean products that contain lead but are compliant with EU RoHS pursuant to a specific EU RoHS exemption.

Green: TI defines "Green" to mean the content of Chlorine (Cl) and Bromine (Br) based flame retardants meet JS709B low halogen requirements of <=1000ppm threshold. Antimony trioxide based flame retardants must also meet the <=1000ppm threshold requirement.

(3) MSL, Peak Temp. - The Moisture Sensitivity Level rating according to the JEDEC industry standard classifications, and peak solder temperature.

(4) There may be additional marking, which relates to the logo, the lot trace code information, or the environmental category on the device.

(5) Multiple Device Markings will be inside parentheses. Only one Device Marking contained in parentheses and separated by a "~" will appear on a device. If a line is indented then it is a continuation of the previous line and the two combined represent the entire Device Marking for that device.

(6) Lead finish/Ball material - Orderable Devices may have multiple material finish options. Finish options are separated by a vertical ruled line. Lead finish/Ball material values may wrap to two lines if the finish value exceeds the maximum column width.

Important Information and Disclaimer:The information provided on this page represents TI's knowledge and belief as of the date that it is provided. TI bases its knowledge and belief on information provided by third parties, and makes no representation or warranty as to the accuracy of such information. Efforts are underway to better integrate information from third parties. TI has taken and continues to take reasonable steps to provide representative and accurate information but may not have conducted destructive testing or chemical analysis on incoming materials and chemicals. TI and TI suppliers consider certain information to be proprietary, and thus CAS numbers and other limited information may not be available for release.

In no event shall TI's liability arising out of such information exceed the total purchase price of the TI part(s) at issue in this document sold by TI to Customer on an annual basis.

TAPE AND REEL INFORMATION

QUADRANT ASSIGNMENTS FOR PIN 1 ORIENTATION IN TAPE

*All dimensions are nominal

Device	Package Type	Package Drawing	Pins	SPQ	Reel Diameter (mm)	Reel Width W1 (mm)	A0 (mm)	B0 (mm)	K0 (mm)	P1 (mm)	W (mm)	Pin1 Quadrant
TPS65265RHBR	VQFN	RHB	32	3000	330.0	12.4	5.3	5.3	1.1	8.0	12.0	Q2
TPS65265RHBT	VQFN	RHB	32	250	180.0	12.4	5.3	5.3	1.1	8.0	12.0	Q2

TAPE AND REEL BOX DIMENSIONS

*All dimensions are nominal

Device	Package Type	Package Drawing	Pins	SPQ	Length (mm)	Width (mm)	Height (mm)
TPS65265RHBR	VQFN	RHB	32	3000	367.0	367.0	35.0
TPS65265RHBT	VQFN	RHB	32	250	210.0	185.0	35.0

GENERIC PACKAGE VIEW

RHB 32

VQFN - 1 mm max height

5 x 5, 0.5 mm pitch

PLASTIC QUAD FLATPACK - NO LEAD



Images above are just a representation of the package family, actual package may vary.
Refer to the product data sheet for package details.

4224745/A

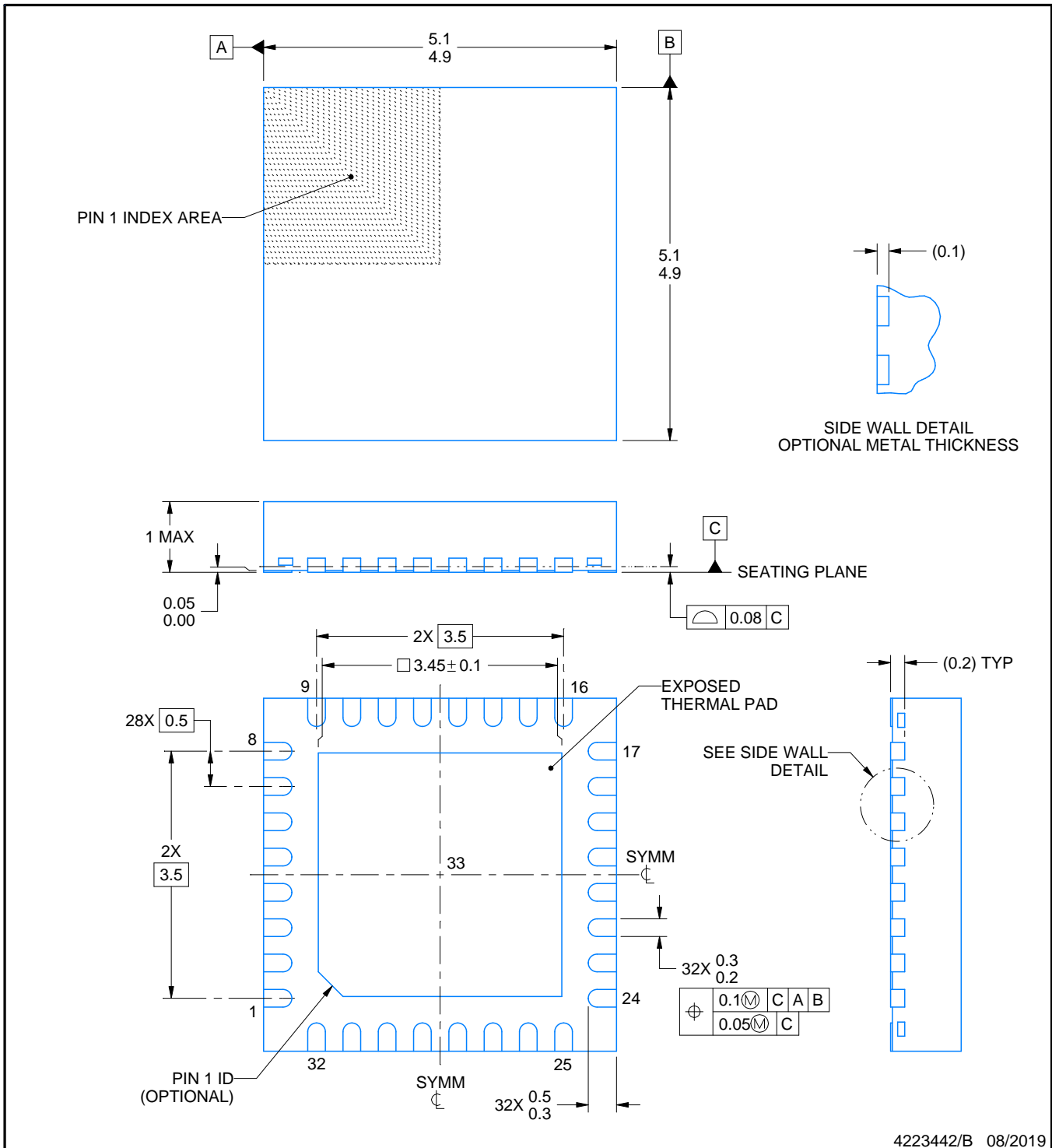

NOTES:

1. All linear dimensions are in millimeters. Any dimensions in parenthesis are for reference only. Dimensioning and tolerancing per ASME Y14.5M.
2. This drawing is subject to change without notice.
3. The package thermal pad must be soldered to the printed circuit board for thermal and mechanical performance.

EXAMPLE BOARD LAYOUT

RHB0032E

VQFN - 1 mm max height

PLASTIC QUAD FLATPACK - NO LEAD



LAND PATTERN EXAMPLE
SCALE:18X



SOLDER MASK DETAILS

4223442/B 08/2019

NOTES: (continued)

- This package is designed to be soldered to a thermal pad on the board. For more information, see Texas Instruments literature number SLUA271 (www.ti.com/lit/slua271).
- Vias are optional depending on application, refer to device data sheet. If any vias are implemented, refer to their locations shown on this view. It is recommended that vias under paste be filled, plugged or tented.

EXAMPLE STENCIL DESIGN

RHB0032E

VQFN - 1 mm max height

PLASTIC QUAD FLATPACK - NO LEAD

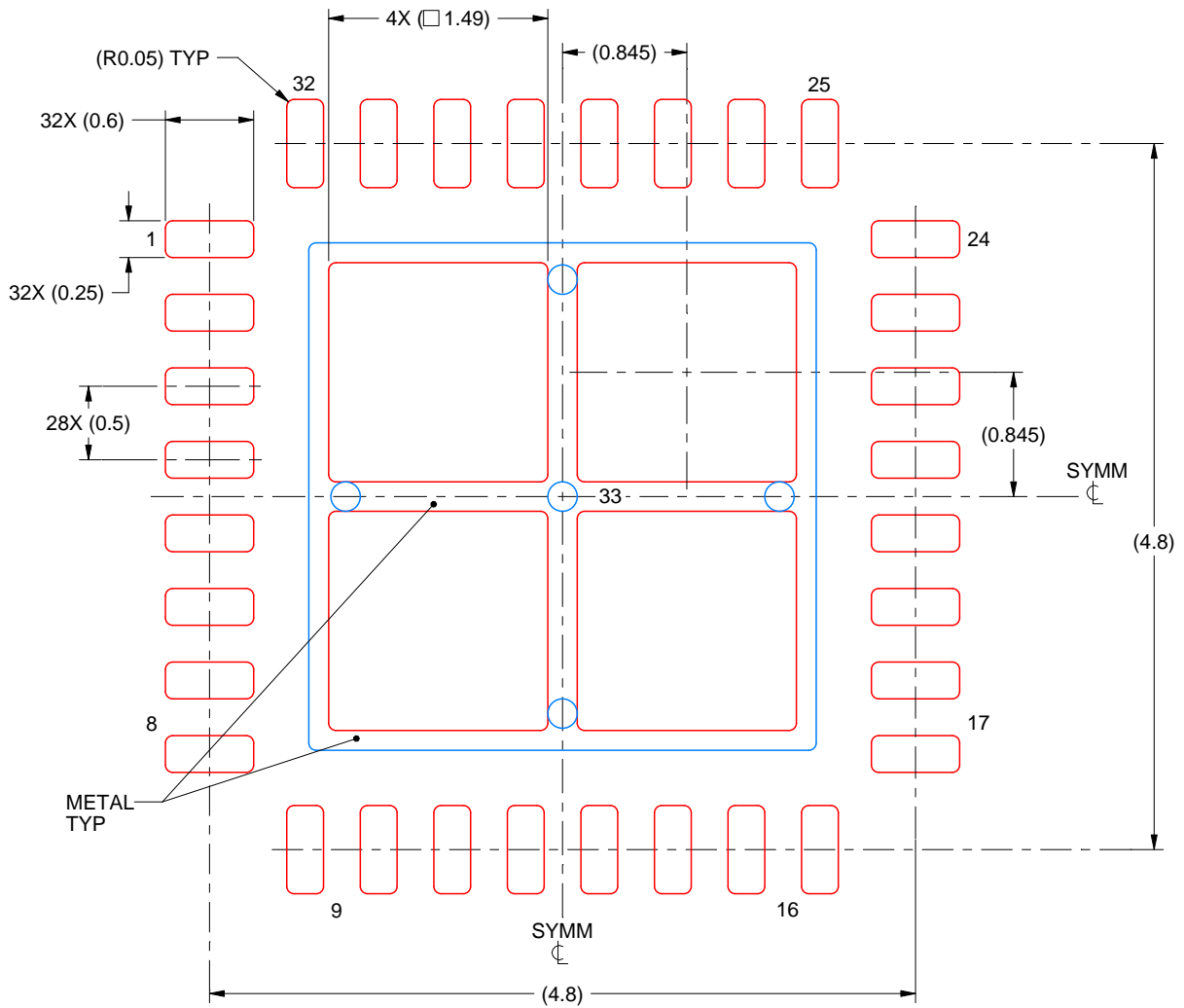

SOLDER PASTE EXAMPLE
 BASED ON 0.125 mm THICK STENCIL

EXPOSED PAD 33:
 75% PRINTED SOLDER COVERAGE BY AREA UNDER PACKAGE
 SCALE:20X

4223442/B 08/2019

NOTES: (continued)

6. Laser cutting apertures with trapezoidal walls and rounded corners may offer better paste release. IPC-7525 may have alternate design recommendations.

重要声明和免责声明

TI 均以“原样”提供技术性 & 可靠性数据（包括数据表）、设计资源（包括参考设计）、应用或其他设计建议、网络工具、安全信息和其他资源，不保证其中不含任何瑕疵，且不做任何明示或暗示的担保，包括但不限于对适销性、适合某特定用途或不侵犯任何第三方知识产权的暗示担保。

所述资源可供专业开发人员应用 TI 产品进行设计使用。您将对以下行为独自承担全部责任：(1) 针对您的应用选择合适的 TI 产品；(2) 设计、验证并测试您的应用；(3) 确保您的应用满足相应标准以及任何其他安全、安保或其他要求。所述资源如有变更，恕不另行通知。TI 对您使用所述资源的授权仅限于开发资源所涉及 TI 产品的相关应用。除此之外不得复制或展示所述资源，也不提供其它 TI 或任何第三方的知识产权授权许可。如因使用所述资源而产生任何索赔、赔偿、成本、损失及债务等，TI 对此概不负责，并且您须赔偿由此对 TI 及其代表造成的损害。

TI 所提供产品均受 TI 的销售条款 (<http://www.ti.com.cn/zh-cn/legal/termsofsale.html>) 以及 [ti.com.cn](http://www.ti.com.cn) 上或随附 TI 产品提供的其他可适用条款的约束。TI 提供所述资源并不扩展或以其他方式更改 TI 针对 TI 产品所发布的可适用的担保范围或担保免责声明。

邮寄地址：上海市浦东新区世纪大道 1568 号中建大厦 32 楼，邮政编码：200122

Copyright © 2020 德州仪器半导体技术（上海）有限公司