

单通道、超低电阻负载开关

 查询样品: [TPS22967](#)

特性

- 集成的单通道负载开关
- 输入电压范围: **0.8V 至 5.5V**
- 超低 $R_{\text{导通}}$ 电阻
 - $V_{\text{输入}} = 5V$ ($V_{\text{偏置}} = 5V$) 时, $R_{\text{导通}} = 22m\Omega$
 - $V_{\text{输入}} = 3.6V$ ($V_{\text{偏置}} = 5V$) 时, $R_{\text{导通}} = 22m\Omega$
 - $V_{\text{输入}} = 1.8V$ ($V_{\text{偏置}} = 5V$) 时, $R_{\text{导通}} = 22m\Omega$
- **4A** 最大持续开关电流
- 低静态电流 (**50 μ A**)
- 低控制输入阈值支持使用 **1.2V/1.8V/2.5V/3.3V** 逻辑电路
- 可配置的上升时间
- 快速输出放电 (**QOD**)
- 带有散热垫的小外形尺寸无引线 (**SON**) 8 引脚封装
- 根据 **JESD 22** 测试得出的静电放电 (**ESD**) 性能
 - **2KV** 人体模型 (**HBM**) 和 **1KV** 器件充电模型 (**CDM**)

应用范围

- **Ultrabook™**
- 笔记本电脑/上网本
- 平板电脑
- 消费类电子产品
- 机顶盒/家庭网关
- 电信系统
- 固态硬盘 (**SSD**)

说明

TPS22967 是一款小型, 超低 $R_{\text{导通}}$ 电阻, 单通道负载开关, 此开关具有受控开启功能。此器件包含一个可在 0.8V 至 5.5V 输入电压范围内运行的 N 通道金属氧化物半导体场效应晶体管 (MOSFET), 并且每通道支持最大 4A 的持续电流。此开关可由一个打开/关闭输入 (ON) 控制, 此输入可与低压控制信号直接对接。在 TPS22967 中, 为了实现开关关闭时的快速输出放电, 增加了一个 225 Ω 的上拉电阻器。

TPS22967 采用小型, 节省空间的 2mm x 2mm 8 引脚 SON 封装 (DSG), 此类封装具有可实现高功率耗散的集成散热垫。器件在自然通风环境下的额定运行温度范围为 -40 $^{\circ}$ C 至 85 $^{\circ}$ C。

特性列表

3.6V ($V_{\text{偏置}} = 5V$) 时, $R_{\text{导通}}$ 的典型值	22m Ω
上升时间 ⁽¹⁾	可调节
快速输出放电	支持
最大输出电流	4A
通用输入输出接口 (GPIO) 启用	高电平有效
工作温度	-40 $^{\circ}$ C 至 85 $^{\circ}$ C
(1) CT 电容值与上升时间之间的关系请参见应用信息部分。	
(2) 这个特性通过一个 225 Ω 电阻器将开关的输出放电至接地 (GND), 从而防止输出悬空。	

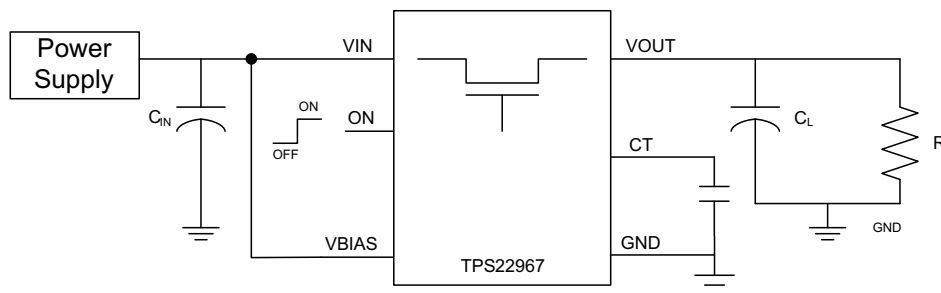

典型应用

ORDERING INFORMATION

For package and ordering information, see the Package Option Addendum at the end of this document.



Please be aware that an important notice concerning availability, standard warranty, and use in critical applications of Texas Instruments semiconductor products and disclaimers thereto appears at the end of this data sheet.

Ultrabook is a trademark of Intel.



These devices have limited built-in ESD protection. The leads should be shorted together or the device placed in conductive foam during storage or handling to prevent electrostatic damage to the MOS gates.

ABSOLUTE MAXIMUM RATINGS

Over operating free-air temperature range (unless otherwise noted)⁽¹⁾⁽²⁾

		VALUE	UNIT ⁽²⁾	
V _{IN}	Input voltage range	-0.3 to 6	V	
V _{OUT}	Output voltage range	-0.3 to 6	V	
V _{BIAS}	Bias voltage range	-0.3 to 6	V	
V _{ON}	ON voltage range	-0.3 to 6	V	
I _{MAX}	Maximum continuous switch current	4	A	
I _{PLS}	Maximum pulsed switch current, pulse <300 μs, 2% duty cycle	6	A	
T _A	Operating free-air temperature range ⁽³⁾	-40 to 85	°C	
T _J	Maximum junction temperature	125	°C	
T _{STG}	Storage temperature range	-65 to 150	°C	
T _{LEAD}	Maximum lead temperature (10-s soldering time)	300	°C	
ESD	Electrostatic discharge protection	Human-Body Model (HBM)	2000	V
		Charged-Device Model (CDM)	1000	

- Stresses beyond those listed under absolute maximum ratings may cause permanent damage to the device. These are stress ratings only, and functional operation of the device at these or any other conditions beyond those indicated under recommended operating conditions is not implied. Exposure to absolute-maximum-rated conditions for extended periods may affect device reliability.
- All voltage values are with respect to network ground terminal.
- In applications where high power dissipation and/or poor package thermal resistance is present, the maximum ambient temperature may have to be derated. Maximum ambient temperature [T_{A(max)}] is dependent on the maximum operating junction temperature [T_{J(max)}], the maximum power dissipation of the device in the application [P_{D(max)}], and the junction-to-ambient thermal resistance of the part/package in the application (θ_{JA}), as given by the following equation: T_{A(max)} = T_{J(max)} - (θ_{JA} × P_{D(max)})

THERMAL INFORMATION

THERMAL METRIC ⁽¹⁾		TPS22967	UNITS
		DSG (8 PINS)	
θ _{JA}	Junction-to-ambient thermal resistance	65.3	°C/W
θ _{JCtop}	Junction-to-case (top) thermal resistance	74.2	
θ _{JB}	Junction-to-board thermal resistance	35.4	
ψ _{JT}	Junction-to-top characterization parameter	2.2	
ψ _{JB}	Junction-to-board characterization parameter	36.0	
θ _{JCbot}	Junction-to-case (bottom) thermal resistance	12.8	

- 有关传统和全新热度的更多信息，请参阅 *IC 封装热量应用报告* (文献号: ZHCA543)。

RECOMMENDED OPERATING CONDITIONS

			MIN	MAX	UNIT
V_{IN}	Input voltage range		0.8	V_{BIAS}	V
V_{BIAS}	Bias voltage range		2.5	5.5	V
V_{ON}	ON voltage range		0	5.5	V
V_{OUT}	Output voltage range			V_{IN}	V
V_{IH}	High-level input voltage, ON	$V_{BIAS} = 2.5\text{ V to }5.5\text{ V}$	1.2	5.5	V
V_{IL}	Low-level input voltage, ON	$V_{BIAS} = 2.5\text{ V to }5.5\text{ V}$	0	0.5	V
C_{IN}	Input capacitor		1 ⁽¹⁾		μF

(1) Refer to Application Information section.

ELECTRICAL CHARACTERISTICS

Unless otherwise noted, the specification in the following table applies over the operating ambient temperature $-40^{\circ}\text{C} \leq T_A \leq 85^{\circ}\text{C}$ (Full) and $V_{BIAS} = 5.0\text{ V}$. Typical values are for $T_A = 25^{\circ}\text{C}$.

PARAMETER		TEST CONDITIONS	T_A	MIN	TYP	MAX	UNIT	
POWER SUPPLIES AND CURRENTS								
$I_{IN(VBIAS-ON)}$	V_{BIAS} quiescent current	$I_{OUT} = 0$, $V_{IN} = V_{ON} = V_{BIAS} = 5.0\text{ V}$	Full		50	75	μA	
$I_{IN(VBIAS-OFF)}$	V_{BIAS} shutdown current	$V_{ON} = \text{GND}$, $V_{OUT} = 0\text{ V}$	Full			2	μA	
$I_{IN(VIN-OFF)}$	V_{IN} off-state supply current	$V_{ON} = \text{GND}$, $V_{OUT} = 0\text{ V}$	Full		$V_{IN} = 5.0\text{ V}$	0.2	8	μA
					$V_{IN} = 3.3\text{ V}$	0.02	3	
					$V_{IN} = 1.8\text{ V}$	0.01	2	
					$V_{IN} = 0.8\text{ V}$	0.005	1	
I_{ON}	ON pin input leakage current	$V_{ON} = 5.5\text{ V}$	Full			0.5	μA	
RESISTANCE CHARACTERISTICS								
R_{ON}	ON-state resistance	$I_{OUT} = -200\text{ mA}$, $V_{BIAS} = 5.0\text{ V}$	$V_{IN} = 5.0\text{ V}$	25°C	22	33	$\text{m}\Omega$	
				Full		35		
			$V_{IN} = 3.3\text{ V}$	25°C	22	33	$\text{m}\Omega$	
				Full		35		
			$V_{IN} = 1.8\text{ V}$	25°C	22	33	$\text{m}\Omega$	
				Full		35		
			$V_{IN} = 1.5\text{ V}$	25°C	22	33	$\text{m}\Omega$	
				Full		35		
			$V_{IN} = 1.2\text{ V}$	25°C	22	33	$\text{m}\Omega$	
				Full		35		
			$V_{IN} = 0.8\text{ V}$	25°C	22	33	$\text{m}\Omega$	
				Full		35		
R_{PD}	Output pulldown resistance	$V_{IN} = 5.0\text{ V}$, $V_{ON} = 0\text{ V}$, $I_{OUT} = 15\text{ mA}$	Full		225	300	Ω	

ELECTRICAL CHARACTERISTICS

Unless otherwise noted, the specification in the following table applies over the operating ambient temperature $-40^{\circ}\text{C} \leq T_A \leq 85^{\circ}\text{C}$ (Full) and $V_{\text{BIAS}} = 2.5\text{ V}$. Typical values are for $T_A = 25^{\circ}\text{C}$.

PARAMETER		TEST CONDITIONS	T_A	MIN	TYP	MAX	UNIT	
POWER SUPPLIES AND CURRENTS								
$I_{\text{IN(VBIAS-ON)}}$	V_{BIAS} quiescent current	$I_{\text{OUT}} = 0$, $V_{\text{IN}} = V_{\text{ON}} = V_{\text{BIAS}} = 2.5\text{ V}$	Full		20	30	μA	
$I_{\text{IN(VBIAS-OFF)}}$	V_{BIAS} shutdown current	$V_{\text{ON}} = \text{GND}$, $V_{\text{OUT}} = 0\text{ V}$	Full			2	μA	
$I_{\text{IN(VIN-OFF)}}$	V_{IN} off-state supply current	$V_{\text{ON}} = \text{GND}$, $V_{\text{OUT}} = 0\text{ V}$	Full		$V_{\text{IN}} = 2.5\text{ V}$	0.01	3	μA
					$V_{\text{IN}} = 1.8\text{ V}$	0.01	2	
					$V_{\text{IN}} = 1.2\text{ V}$	0.005	2	
					$V_{\text{IN}} = 0.8\text{ V}$	0.003	1	
I_{ON}	ON pin input leakage current	$V_{\text{ON}} = 5.5\text{ V}$	Full			0.5	μA	
RESISTANCE CHARACTERISTICS								
R_{ON}	ON-state resistance	$I_{\text{OUT}} = -200\text{ mA}$, $V_{\text{BIAS}} = 2.5\text{ V}$	$V_{\text{IN}} = 2.5\text{ V}$	25°C	26	38	m Ω	
				Full		40		
			$V_{\text{IN}} = 1.8\text{ V}$	25°C	26	38	m Ω	
				Full		40		
			$V_{\text{IN}} = 1.5\text{ V}$	25°C	25	38	m Ω	
				Full		40		
			$V_{\text{IN}} = 1.2\text{ V}$	25°C	24	38	m Ω	
				Full		40		
			$V_{\text{IN}} = 0.8\text{ V}$	25°C	24	38	m Ω	
				Full		40		
R_{PD}	Output pulldown resistance	$V_{\text{IN}} = 2.5\text{ V}$, $V_{\text{ON}} = 0\text{ V}$, $I_{\text{OUT}} = 1\text{ mA}$	Full		275	325	Ω	

SWITCHING CHARACTERISTIC MEASUREMENT INFORMATION

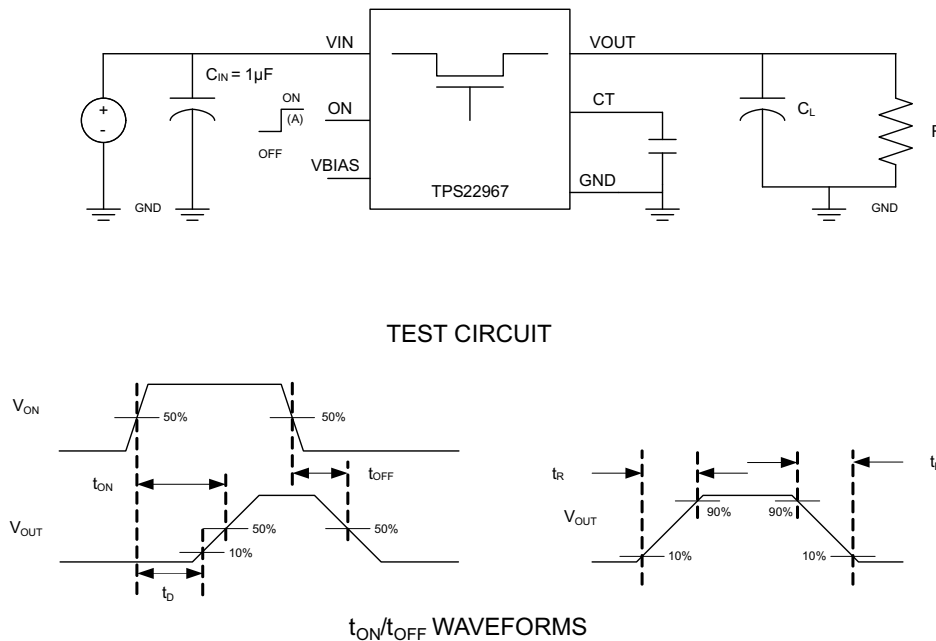

(A) Rise and fall times of the control signal is 100ns.

Figure 1. Test Circuit and Timing Waveforms

SWITCHING CHARACTERISTICS

PARAMETER	TEST CONDITION	MIN	TYP	MAX	UNIT
V_{IN} = V_{ON} = V_{BIAS} = 5 V, T_A = 25°C (unless otherwise noted)					
t _{ON} Turn-on time	R _L = 10-Ω, C _L = 0.1 µF, C _T = 1000 pF		1325		µs
t _{OFF} Turn-off time			10		
t _R V _{OUT} rise time			1625		
t _F V _{OUT} fall time			3.5		
t _D ON delay time			500		
V_{IN} = 0.8 V, V_{ON} = V_{BIAS} = 5V, T_A = 25°C (unless otherwise noted)					
t _{ON} Turn-on time	R _L = 10-Ω, C _L = 0.1 µF, C _T = 1000 pF		600		µs
t _{OFF} Turn-off time			80		
t _R V _{OUT} rise time			300		
t _F V _{OUT} fall time			5.5		
t _D ON delay time			460		
V_{IN} = 2.5V, V_{ON} = 5 V, V_{BIAS} = 2.5V, T_A = 25°C (unless otherwise noted)					
t _{ON} Turn-on time	R _L = 10-Ω, C _L = 0.1 µF, C _T = 1000 pF		2200		µs
t _{OFF} Turn-off time			9		
t _R V _{OUT} rise time			2275		
t _F V _{OUT} fall time			3.1		
t _D ON delay time			1075		
V_{IN} = 0.8 V, V_{ON} = 5 V, V_{BIAS} = 2.5 V, T_A = 25°C (unless otherwise noted)					
t _{ON} Turn-on time	R _L = 10-Ω, C _L = 0.1 µF, C _T = 1000 pF		1450		µs
t _{OFF} Turn-off time			60		
t _R V _{OUT} rise time			875		
t _F V _{OUT} fall time			5.5		
t _D ON delay time			1010		

FUNCTIONAL BLOCK DIAGRAM

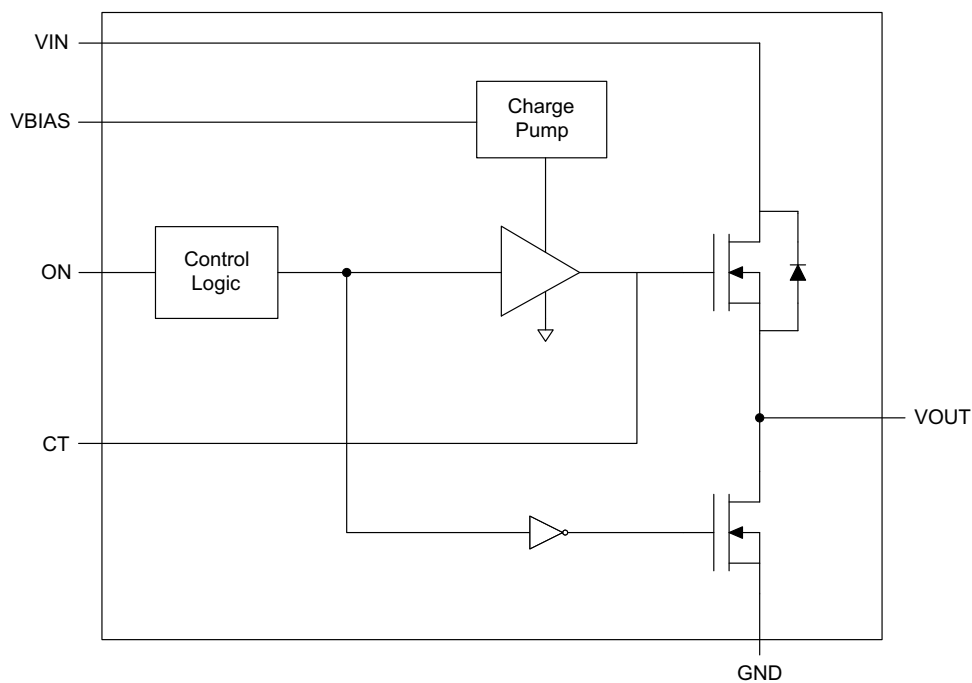
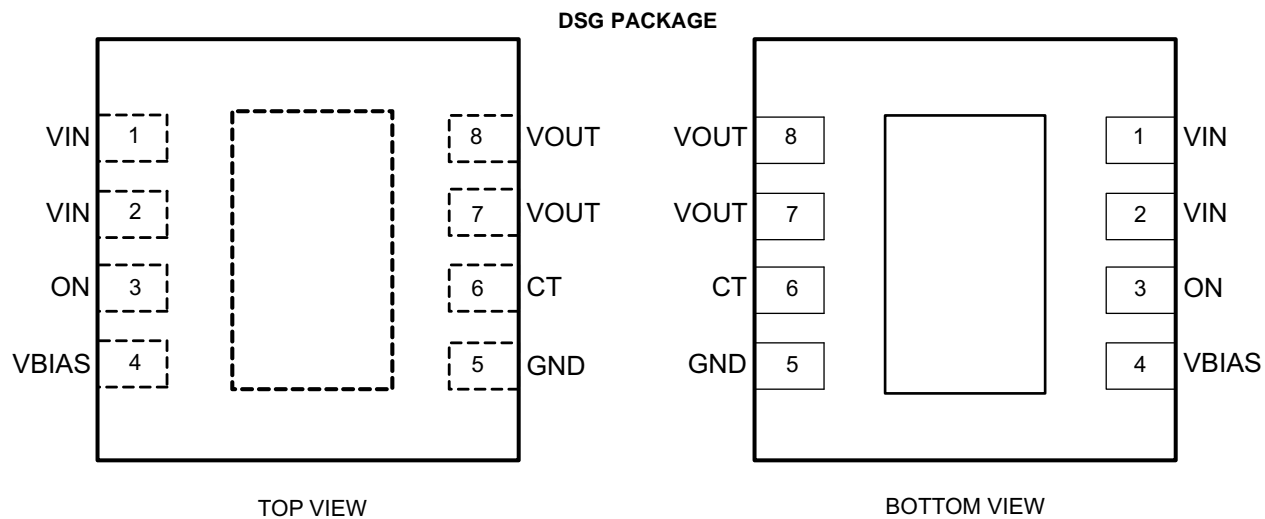

Figure 2. Functional Block Diagram

Table 1. FUNCTIONAL TABLE

ON	VIN to VOUT	VOUT to GND
L	Off	On
H	On	Off

PIN DESCRIPTIONS

TPS22967 DSG	PIN NAME	I/O	DESCRIPTION
1	VIN	I	Switch input. Input capacitor recommended for minimizing V_{IN} dip. Recommended voltage range for this pin for optimal R_{ON} performance is 0.8V to V_{BIAS} .
2	VIN	I	Switch input. Input capacitor recommended for minimizing V_{IN} dip. Recommended voltage range for this pin for optimal R_{ON} performance is 0.8V to V_{BIAS} .
3	ON	I	Active high switch control input. Do not leave floating.
4	VBIAS	I	Bias voltage. Power supply to the device. Recommended voltage range for this pin is 2.5V to 5.5V. See Application Information section for more information.
5	GND	-	Device ground.
6	CT	O	Switch slew rate control. Can be left floating. See Application Information section for more information.
7	VOUT	O	Switch output.
8	VOUT	O	Switch output.
	Thermal Pad	-	Thermal pad (exposed center pad) to alleviate thermal stress. Tie to GND. See Application Information for layout guidelines.

TYPICAL CHARACTERISTICS

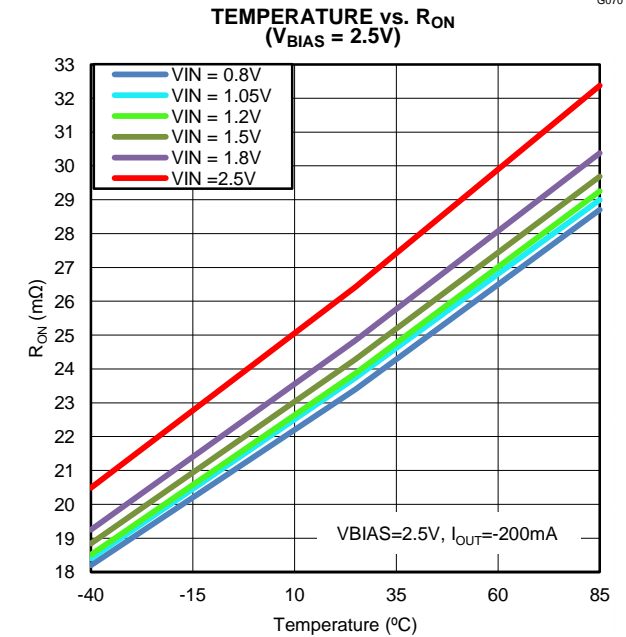
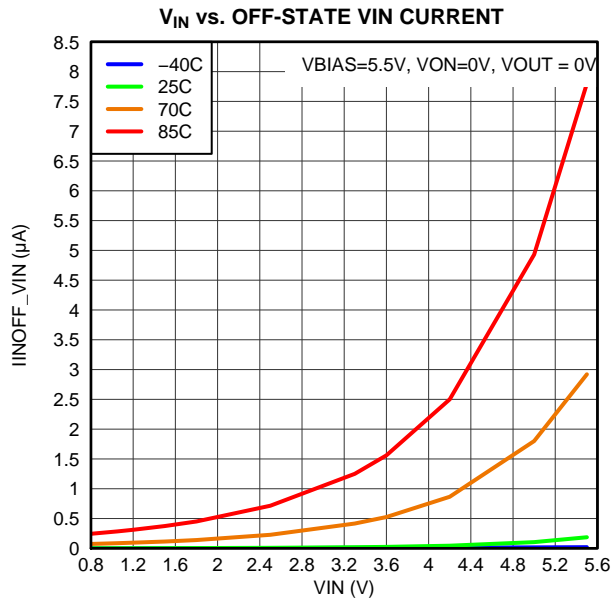
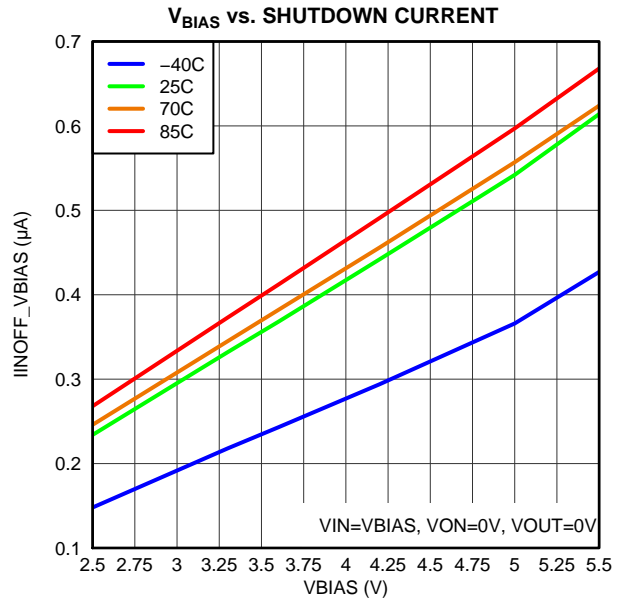
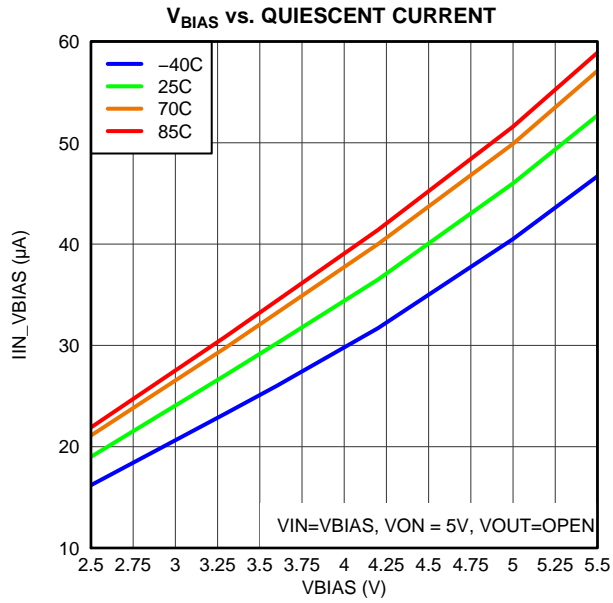

TYPICAL CHARACTERISTICS (continued)

TEMPERATURE vs. R_{ON}
($V_{BIAS} = 5.5V$)

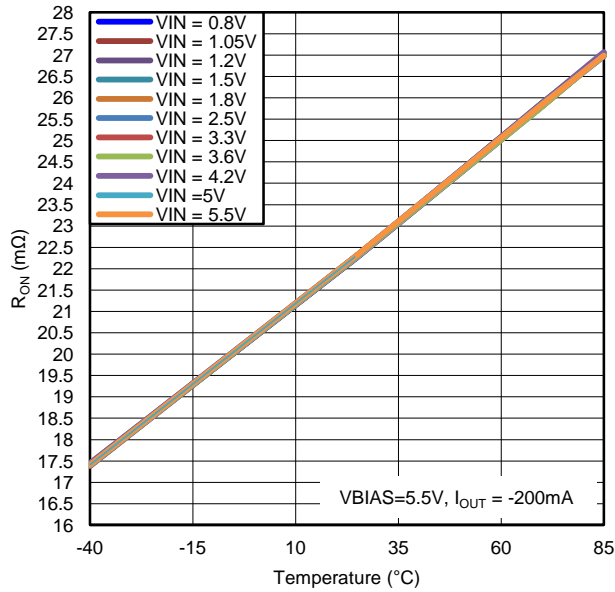

V_{IN} vs. R_{ON}
($V_{BIAS} = 2.5V$)

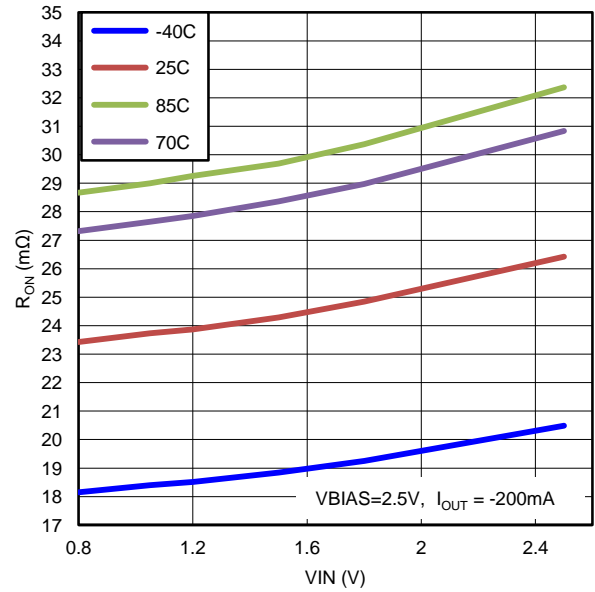

V_{IN} vs. R_{ON}
($V_{BIAS} = 5.5V$)

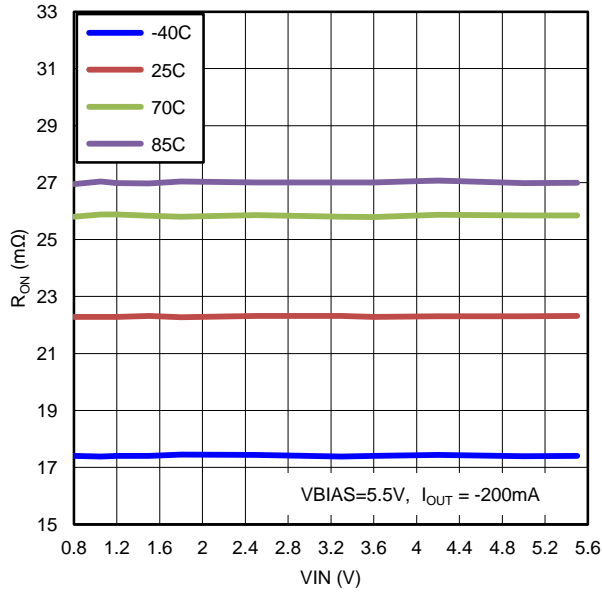

V_{IN} vs. R_{ON}
($T_A = 25^\circ C$)

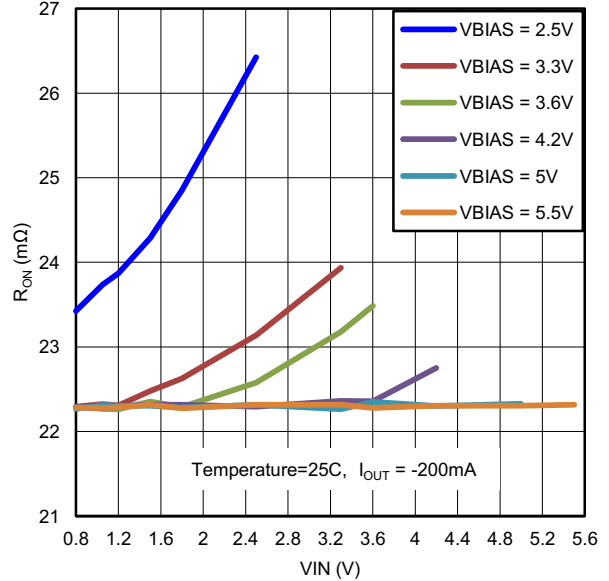

TYPICAL CHARACTERISTICS (continued)

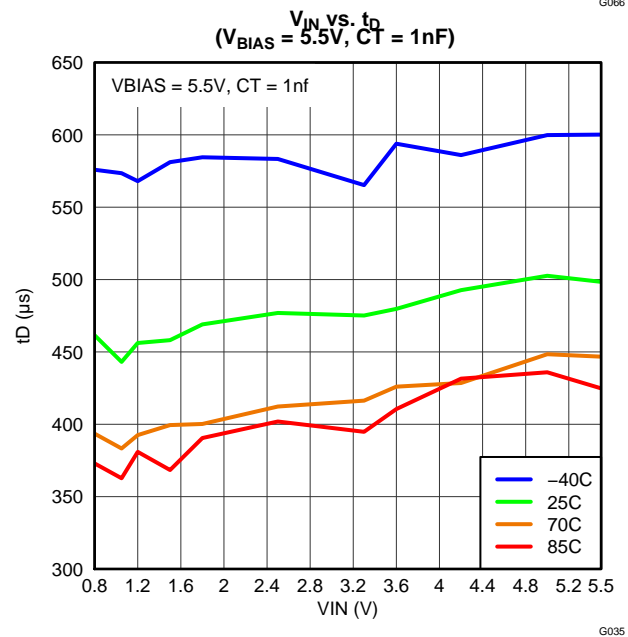
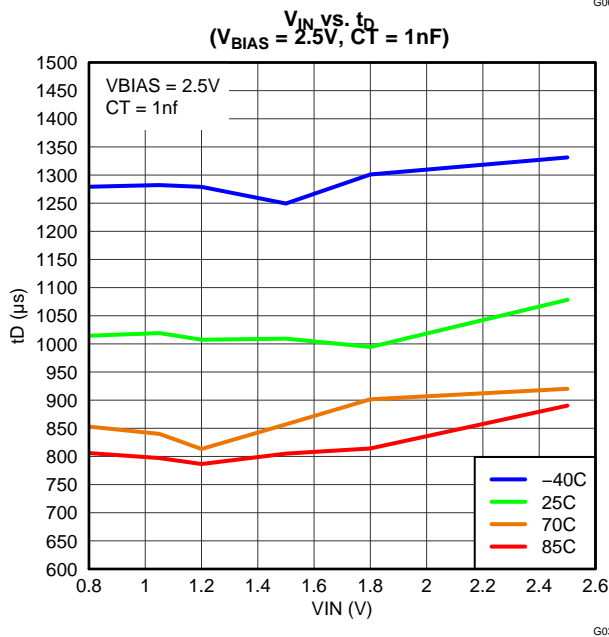
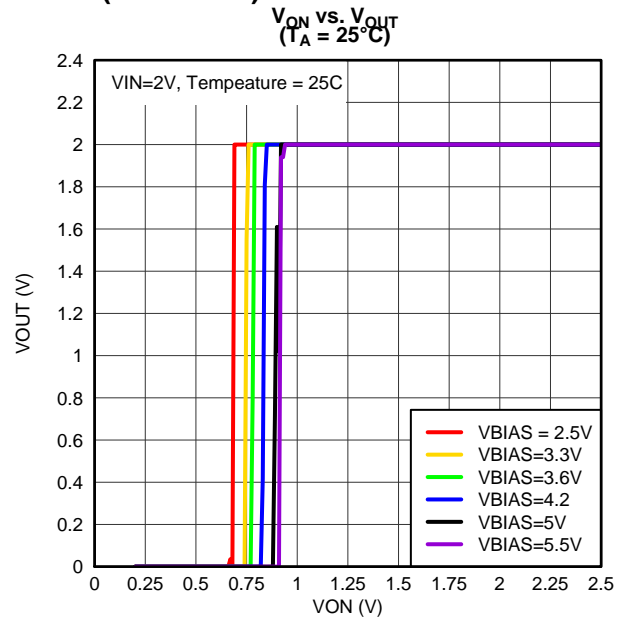
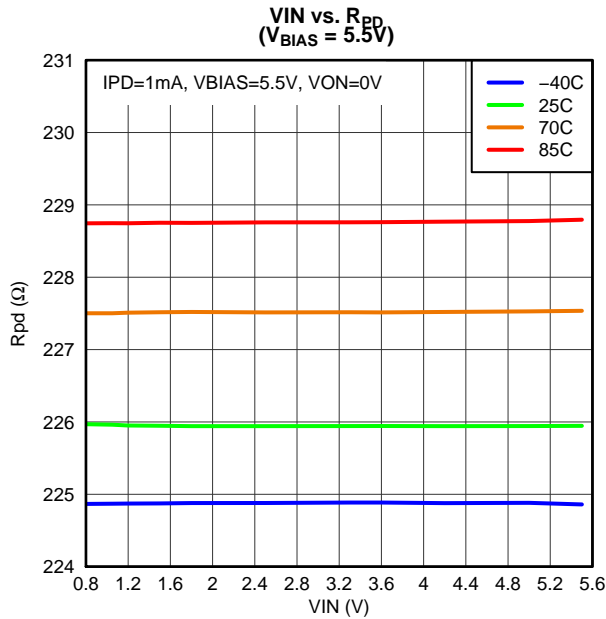

TYPICAL CHARACTERISTICS (continued)

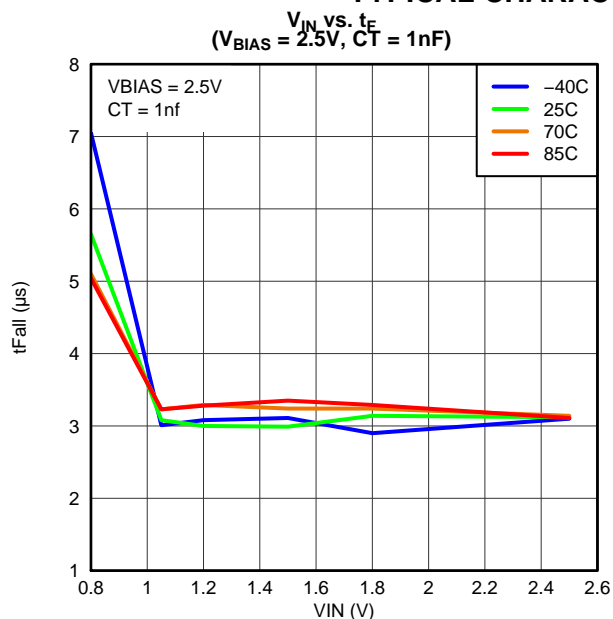

G036

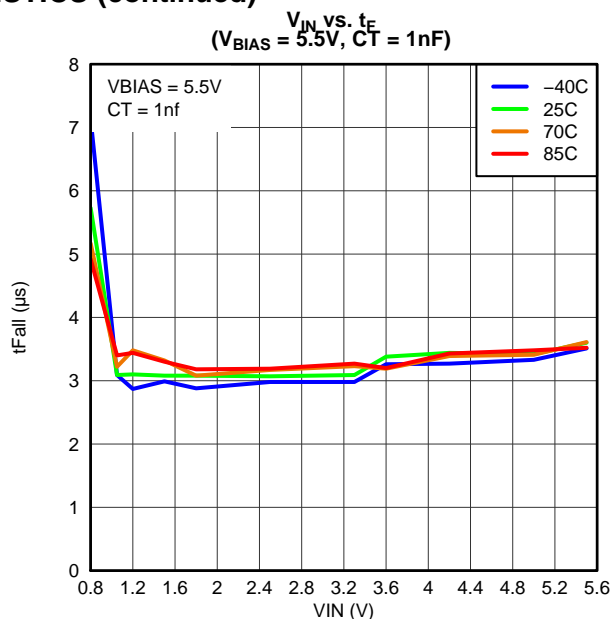

G041

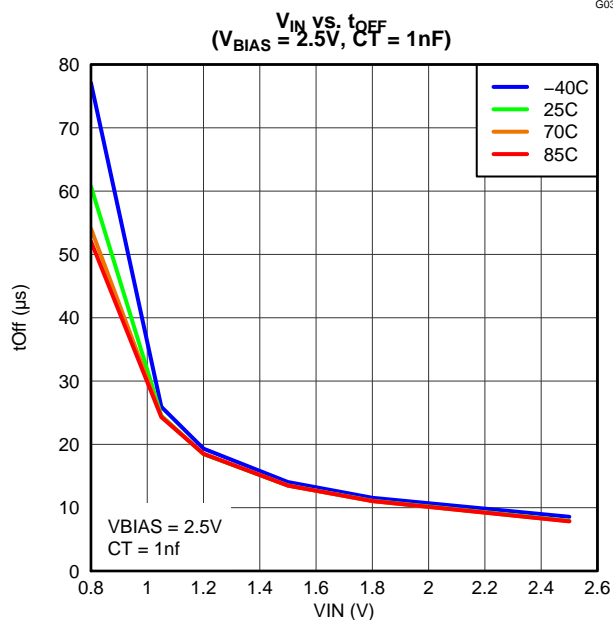

G042

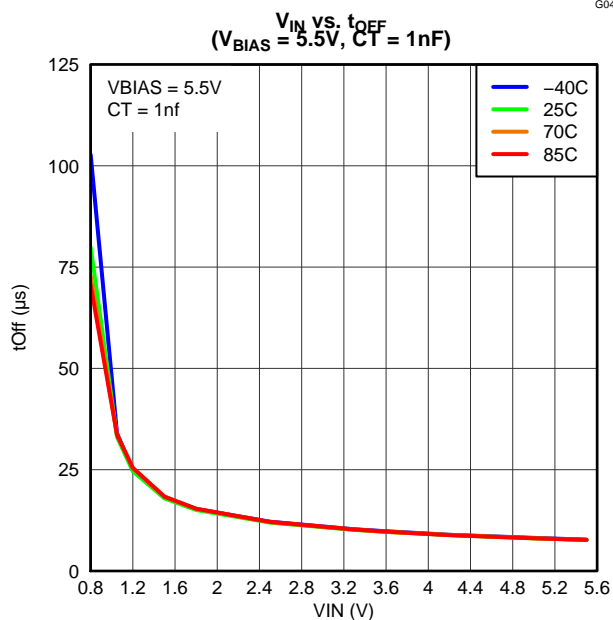

G047

TYPICAL CHARACTERISTICS (continued)

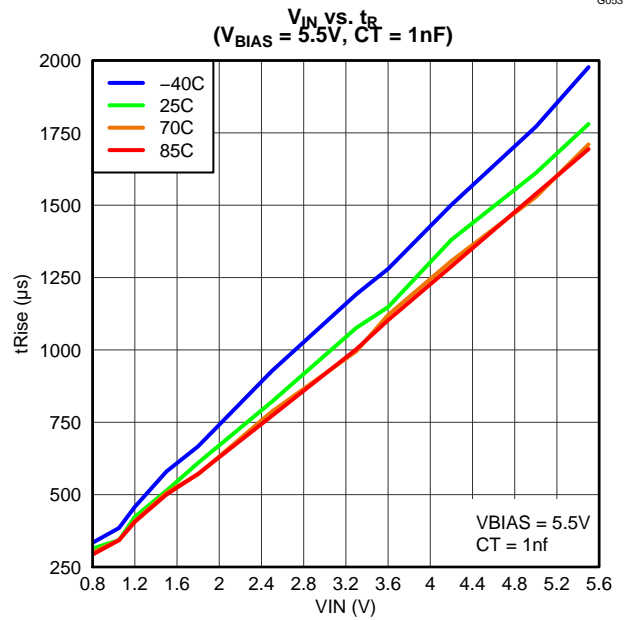
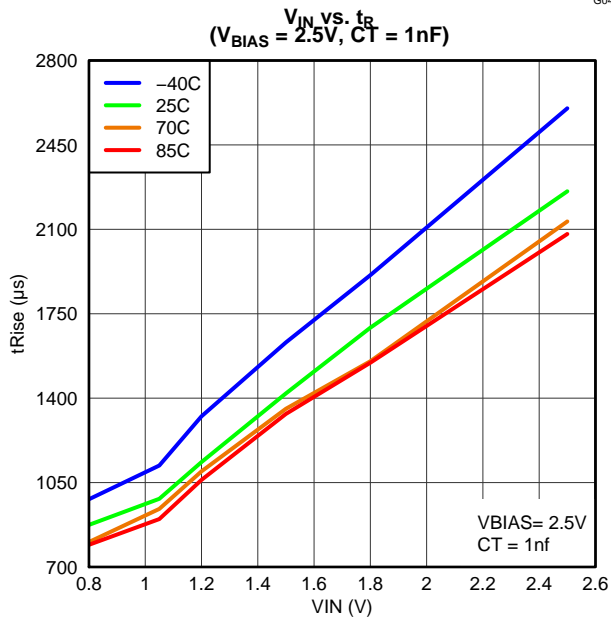
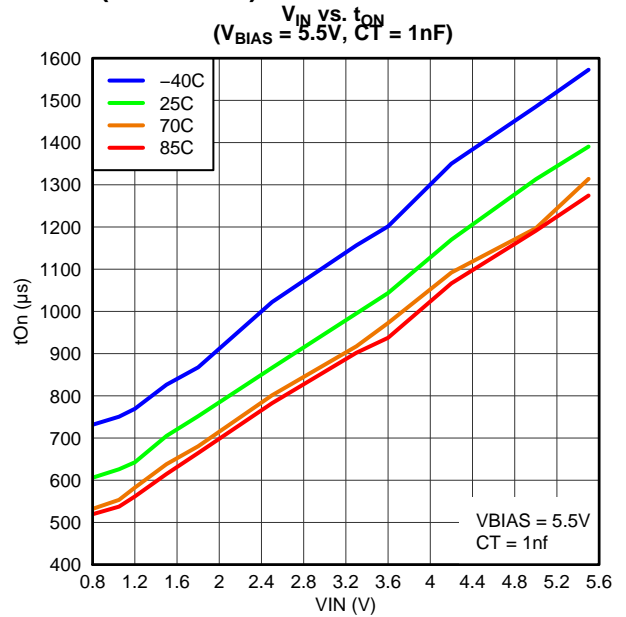
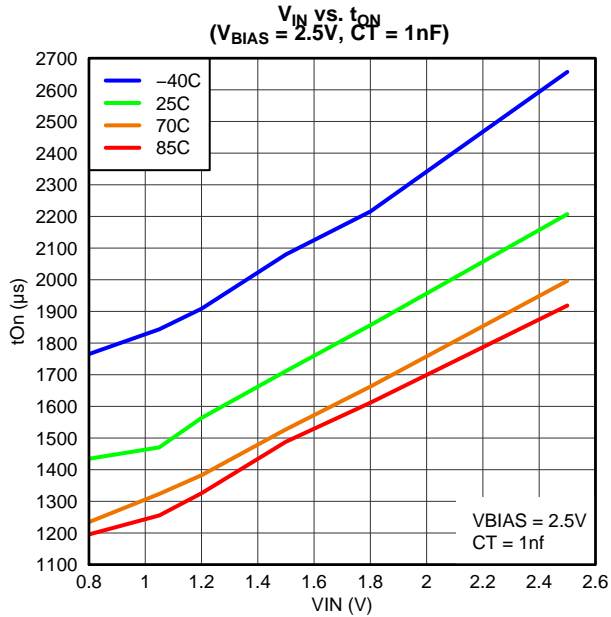

TYPICAL CHARACTERISTICS (continued)

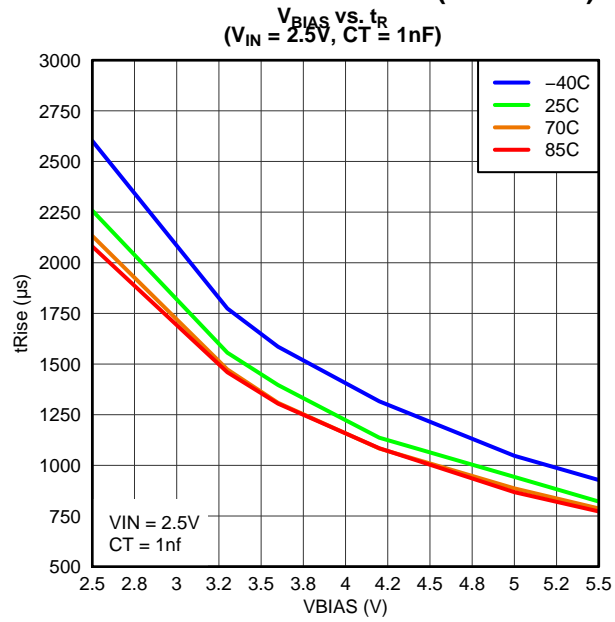

TYPICAL AC SCOPE CAPTURES at $T_A = 25^\circ\text{C}$, $C_T = 1\text{nF}$

TURN-ON RESPONSE TIME
 $(V_{IN} = 0.8\text{V}, V_{BIAS} = 2.5\text{V}, C_{IN} = 1\mu\text{F}, C_L = 0.1\mu\text{F}, R_L = 10\Omega)$
 CH1: VOUT, CH2: ON

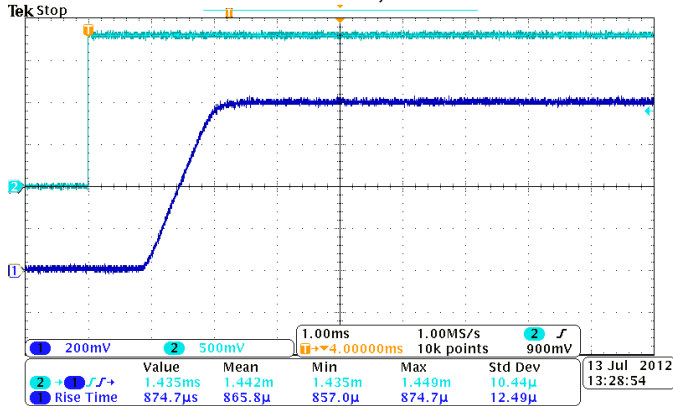

TURN-ON RESPONSE TIME
 $(V_{IN} = 0.8\text{V}, V_{BIAS} = 5.0\text{V}, C_{IN} = 1\mu\text{F}, C_L = 0.1\mu\text{F}, R_L = 10\Omega)$
 CH1: VOUT, CH2: ON

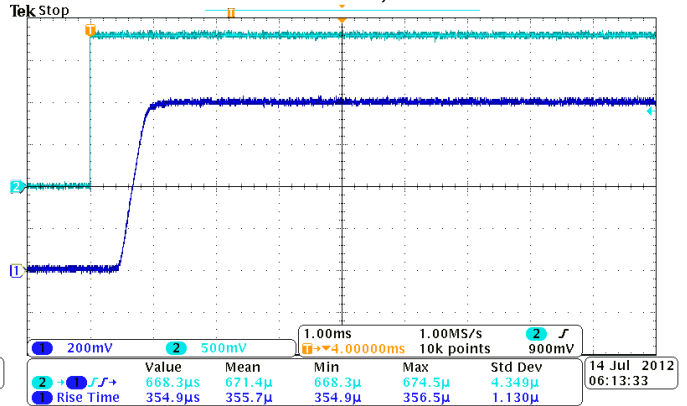

TURN-ON RESPONSE TIME
 $(V_{IN} = 2.5\text{V}, V_{BIAS} = 2.5\text{V}, C_{IN} = 1\mu\text{F}, C_L = 0.1\mu\text{F}, R_L = 10\Omega)$
 CH1: VOUT, CH2: ON

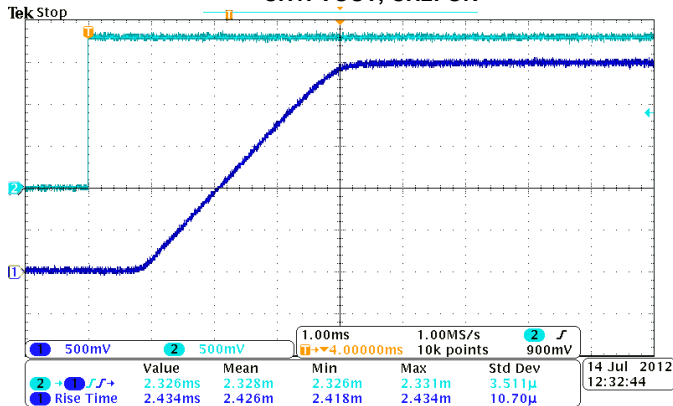

TURN-ON RESPONSE TIME
 $(V_{IN} = 5.0\text{V}, V_{BIAS} = 5.0\text{V}, C_{IN} = 1\mu\text{F}, C_L = 0.1\mu\text{F}, R_L = 10\Omega)$
 CH1: VOUT, CH2: ON

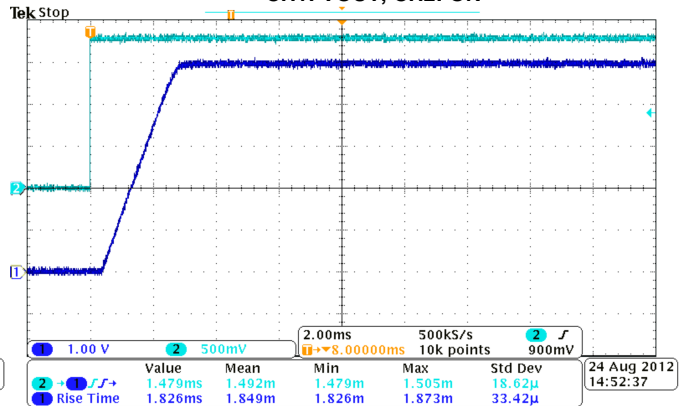

TURN-OFF RESPONSE TIME
 $(V_{IN} = 0.8\text{V}, V_{BIAS} = 2.5\text{V}, C_{IN} = 1\mu\text{F}, C_L = 0.1\mu\text{F}, R_L = 10\Omega)$
 CH1: VOUT, CH2: ON

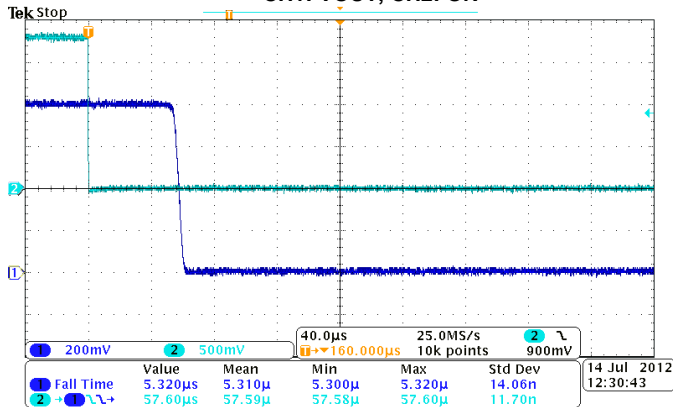

TURN-OFF RESPONSE TIME
 $(V_{IN} = 0.8\text{V}, V_{BIAS} = 5.0\text{V}, C_{IN} = 1\mu\text{F}, C_L = 0.1\mu\text{F}, R_L = 10\Omega)$
 CH1: VOUT, CH2: ON

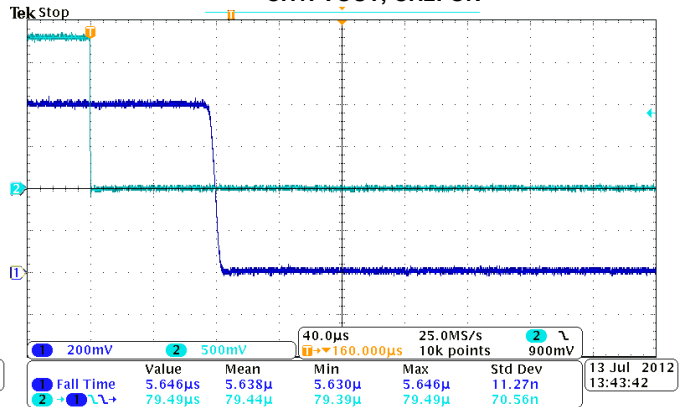

TYPICAL AC SCOPE CAPTURES at $T_A = 25^\circ\text{C}$, $C_T = 1\text{nF}$ (continued)

TURN-OFF RESPONSE TIME
 $(V_{IN} = 2.5\text{V}, V_{BIAS} = 2.5\text{V}, C_{IN} = 1\mu\text{F}, C_L = 0.1\mu\text{F}, R_L = 10\Omega)$
 CH1: VOUT, CH2: ON

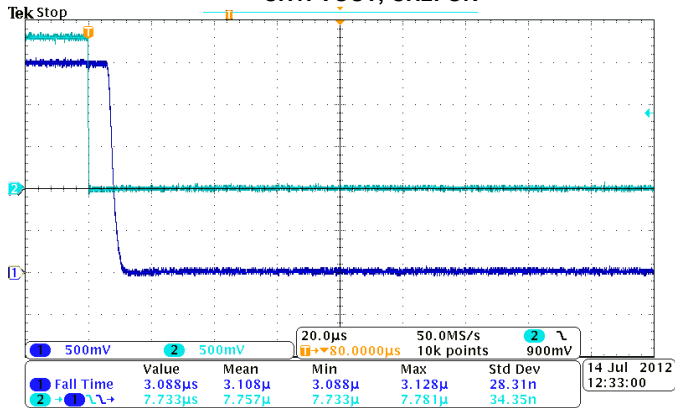

TURN-OFF RESPONSE TIME
 $(V_{IN} = 5.0\text{V}, V_{BIAS} = 5.0\text{V}, C_{IN} = 1\mu\text{F}, C_L = 0.1\mu\text{F}, R_L = 10\Omega)$
 CH1: VOUT, CH2: ON

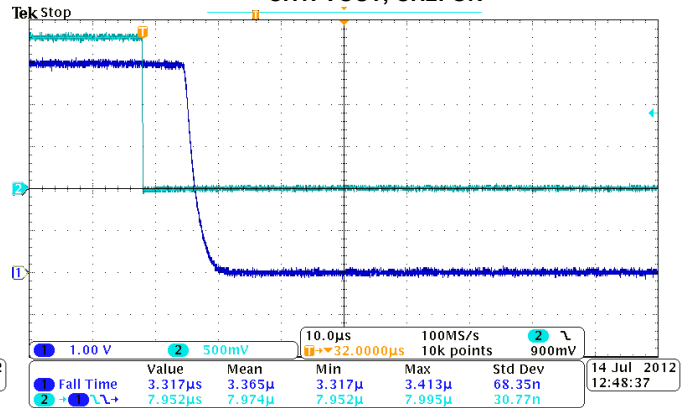

APPLICATION INFORMATION

ON/OFF CONTROL

The ON pin controls the state of the switch. Asserting ON high enables the switch. ON is active high and has a low threshold, making it capable of interfacing with low-voltage signals. The ON pin is compatible with standard GPIO logic thresholds. It can be used with any microcontroller with 1.2V or higher GPIO voltage. This pin cannot be left floating and must be driven either high or low for proper functionality.

INPUT CAPACITOR (OPTIONAL)

To limit the voltage drop on the input supply caused by transient in-rush currents when the switch turns on into a discharged load capacitor or short-circuit, a capacitor needs to be placed between VIN and GND. A 1- μ F ceramic capacitor, C_{IN}, placed close to the pins, is usually sufficient. Higher values of C_{IN} can be used to further reduce the voltage drop during high current applications. When switching heavy loads, it is recommended to have an input capacitor about 10 times higher than the output capacitor to avoid excessive voltage drop.

OUTPUT CAPACITOR (OPTIONAL)

Due to the integrated body diode in the NMOS switch, a C_{IN} greater than C_L is highly recommended. A C_L greater than C_{IN} can cause V_{OUT} to exceed V_{IN} when the system supply is removed. This could result in current flow through the body diode from V_{OUT} to V_{IN}. A C_{IN} to C_L ratio of 10 to 1 is recommended for minimizing V_{IN} dip caused by inrush currents during startup, however a 10 to 1 ratio for capacitance is not required for proper functionality of the device. A ratio smaller than 10 to 1 (such as 1 to 1) could cause slightly more V_{IN} dip upon turn-on due to inrush currents. This can be mitigated by increasing the capacitance on the CT pin for a longer rise time (see below).

V_{IN} and V_{BIAS} VOLTAGE RANGE

For optimal R_{ON} performance, make sure V_{IN} ≤ V_{BIAS}. The device will still be functional if V_{IN} > V_{BIAS} but it will exhibit R_{ON} greater than what is listed in the ELECTRICAL CHARACTERISTICS table. See Figure 3 for an example of a typical device. Notice the increasing R_{ON} as V_{IN} exceeds V_{BIAS} voltage. Be sure to never exceed the maximum voltage rating for VIN and VBIAS.

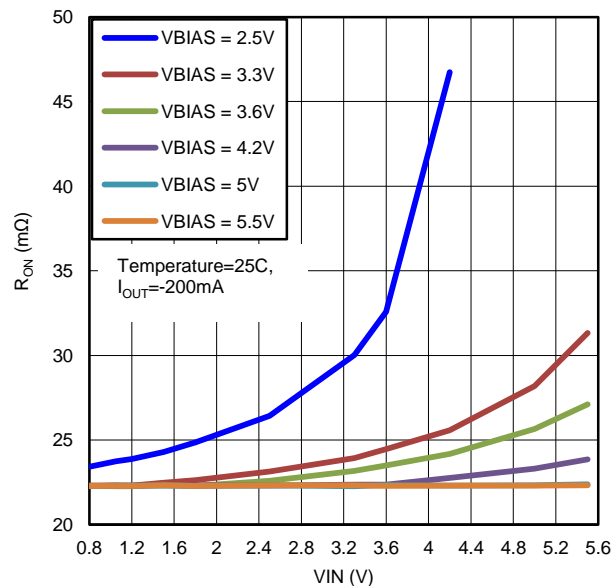

Figure 3. R_{ON} vs. V_{IN} (V_{IN} > V_{BIAS})

ADJUSTABLE RISE TIME

A capacitor to GND on the CT pin sets the VOUT slew rate. The voltage on the CT pin can be as high as 12V. Therefore, the minimum voltage rating for the CT cap should be 25V for optimal performance. An approximate formula for the relationship between CT and slew rate is (the equation below accounts for 10% to 90% measurement on V_{OUT} and does **NOT** apply for CT = 0pF. Use table below to determine rise times for when CT = 0pF):

$$SR = 0.39 \times CT + 13.4 \quad (1)$$

Where,

SR = slew rate (in $\mu\text{s}/\text{V}$)

CT = the capacitance value on the CT pin (in pF)

The units for the constant 13.4 is in $\mu\text{s}/\text{V}$. The units for the constant 0.39 are in $\mu\text{s}/(\text{V} \times \text{pF})$.

Rise time can be calculated by multiplying the input voltage by the slew rate. The table below contains rise time values measured on a typical device. Rise times shown below are only valid for the power-up sequence where V_{IN} and V_{BIAS} are already in steady state condition, and the ON pin is asserted high.

CTx (pF)	RISE TIME (μs) 10% - 90%, C _L = 0.1 μF , C _{IN} = 1 μF , R _L = 10 Ω TYPICAL VALUES at 25°C, 25V X7R 10% CERAMIC CAP						
	5V	3.3V	1.8V	1.5V	1.2V	1.05V	0.8V
0	127	93	62	55	51	46	42
220	475	314	188	162	141	125	103
470	939	637	359	304	255	218	188
1000	1869	1229	684	567	476	414	344
2200	4020	2614	1469	1211	1024	876	681
4700	8690	5746	3167	2703	2139	1877	1568
10000	18360	12550	6849	5836	4782	4089	3449

SAFE OPERATING AREA (SOA)

The SOA curves show the continuous current carrying capability of the device versus ambient temperature (T_A) to ensure reliable operation over 70,000 hours of device lifetime. The different curves represent the *percentage On time* over device lifetime and can be used as a reference to understand the current carrying capability of TPS22967 under different use cases. It is recommended to maintain continuous current at or below the SOA curves shown in Figure 4.

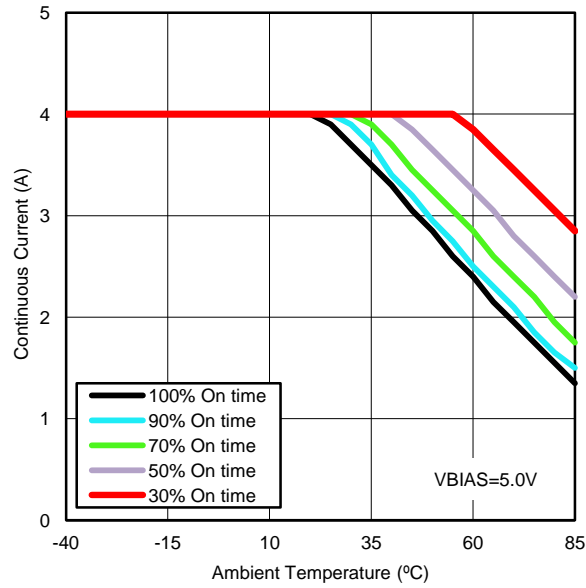

“On time” is the duration of time that the device is enabled ($ON \geq V_{IH}$) over 70,000 hour lifetime.

Figure 4. Safe Operating Area

BOARD LAYOUT AND THERMAL CONSIDERATIONS

For best performance, all traces should be as short as possible. To be most effective, the input and output capacitors should be placed close to the device to minimize the effects that parasitic trace inductances may have on normal operation. Using wide traces for VIN, VOUT, and GND helps minimize the parasitic electrical effects along with minimizing the case to ambient thermal impedance.

The maximum IC junction temperature should be restricted to 125°C under normal operating conditions. To calculate the maximum allowable dissipation, $P_{D(max)}$ for a given output current and ambient temperature, use the following equation as a guideline:

$$P_{D(max)} = \frac{T_{J(max)} - T_A}{\Theta_{JA}} \quad (2)$$

Where:

$P_{D(max)}$ = maximum allowable power dissipation

$T_{J(max)}$ = maximum allowable junction temperature (125°C for the TPS22967)

T_A = ambient temperature of the device

Θ_{JA} = junction to air thermal impedance. See Thermal Information section. This parameter is highly dependent upon board layout.

The figure below shows an example of a layout. Notice the thermal vias located under the exposed thermal pad of the device. This allows for thermal diffusion away from the device.

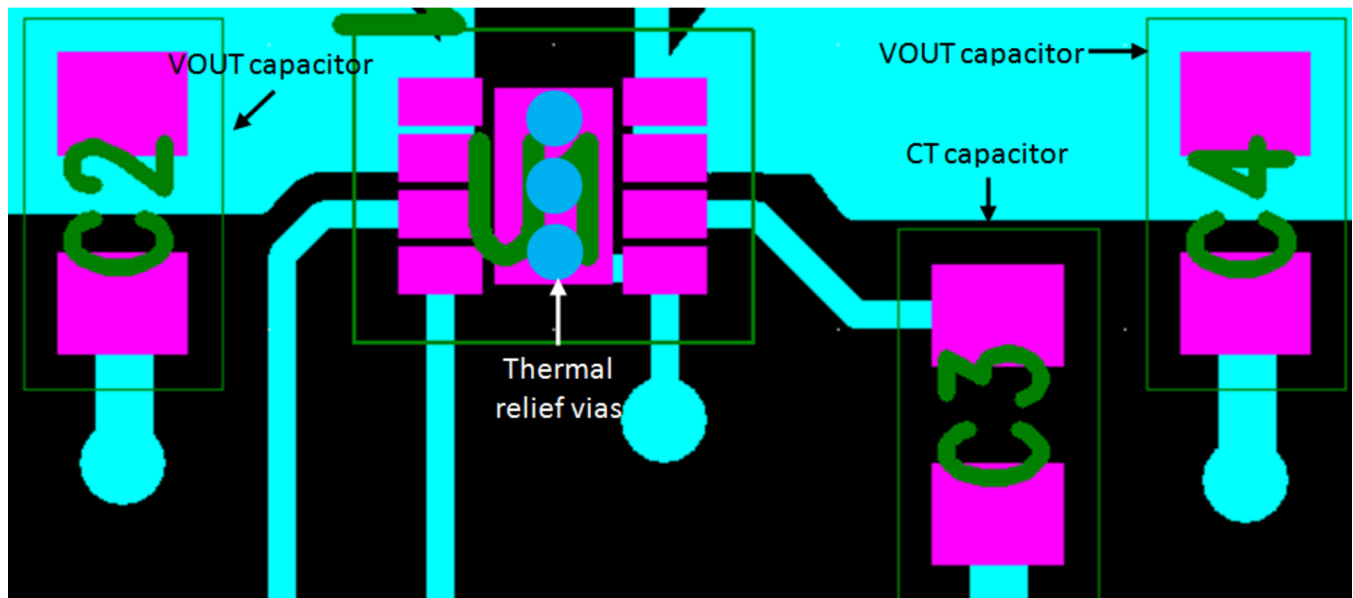

PACKAGING INFORMATION

Orderable Device	Status (1)	Package Type	Package Drawing	Pins	Package Qty	Eco Plan (2)	Lead finish/ Ball material (6)	MSL Peak Temp (3)	Op Temp (°C)	Device Marking (4/5)	Samples
TPS22967DSGR	ACTIVE	WSON	DSG	8	3000	RoHS & Green	NIPDAU	Level-2-260C-1 YEAR	-40 to 85	ZTU	Samples
TPS22967DSGT	ACTIVE	WSON	DSG	8	250	RoHS & Green	NIPDAU	Level-2-260C-1 YEAR	-40 to 85	ZTU	Samples

(1) The marketing status values are defined as follows:

ACTIVE: Product device recommended for new designs.

LIFEBUY: TI has announced that the device will be discontinued, and a lifetime-buy period is in effect.

NRND: Not recommended for new designs. Device is in production to support existing customers, but TI does not recommend using this part in a new design.

PREVIEW: Device has been announced but is not in production. Samples may or may not be available.

OBSOLETE: TI has discontinued the production of the device.

(2) **RoHS:** TI defines "RoHS" to mean semiconductor products that are compliant with the current EU RoHS requirements for all 10 RoHS substances, including the requirement that RoHS substance do not exceed 0.1% by weight in homogeneous materials. Where designed to be soldered at high temperatures, "RoHS" products are suitable for use in specified lead-free processes. TI may reference these types of products as "Pb-Free".

RoHS Exempt: TI defines "RoHS Exempt" to mean products that contain lead but are compliant with EU RoHS pursuant to a specific EU RoHS exemption.

Green: TI defines "Green" to mean the content of Chlorine (Cl) and Bromine (Br) based flame retardants meet JS709B low halogen requirements of <=1000ppm threshold. Antimony trioxide based flame retardants must also meet the <=1000ppm threshold requirement.

(3) MSL, Peak Temp. - The Moisture Sensitivity Level rating according to the JEDEC industry standard classifications, and peak solder temperature.

(4) There may be additional marking, which relates to the logo, the lot trace code information, or the environmental category on the device.

(5) Multiple Device Markings will be inside parentheses. Only one Device Marking contained in parentheses and separated by a "~" will appear on a device. If a line is indented then it is a continuation of the previous line and the two combined represent the entire Device Marking for that device.

(6) Lead finish/Ball material - Orderable Devices may have multiple material finish options. Finish options are separated by a vertical ruled line. Lead finish/Ball material values may wrap to two lines if the finish value exceeds the maximum column width.

Important Information and Disclaimer:The information provided on this page represents TI's knowledge and belief as of the date that it is provided. TI bases its knowledge and belief on information provided by third parties, and makes no representation or warranty as to the accuracy of such information. Efforts are underway to better integrate information from third parties. TI has taken and continues to take reasonable steps to provide representative and accurate information but may not have conducted destructive testing or chemical analysis on incoming materials and chemicals. TI and TI suppliers consider certain information to be proprietary, and thus CAS numbers and other limited information may not be available for release.

In no event shall TI's liability arising out of such information exceed the total purchase price of the TI part(s) at issue in this document sold by TI to Customer on an annual basis.

GENERIC PACKAGE VIEW

DSG 8

WSON - 0.8 mm max height

2 x 2, 0.5 mm pitch

PLASTIC SMALL OUTLINE - NO LEAD

This image is a representation of the package family, actual package may vary.
Refer to the product data sheet for package details.



4224783/A

DSG0008A



PACKAGE OUTLINE

WSON - 0.8 mm max height

PLASTIC SMALL OUTLINE - NO LEAD



ALTERNATIVE TERMINAL SHAPE TYPICAL



SIDE WALL METAL THICKNESS DIM A	
OPTION 1	OPTION 2
0.1	0.2



4218900/E 08/2022

NOTES:

1. All linear dimensions are in millimeters. Any dimensions in parenthesis are for reference only. Dimensioning and tolerancing per ASME Y14.5M.
2. This drawing is subject to change without notice.
3. The package thermal pad must be soldered to the printed circuit board for thermal and mechanical performance.

EXAMPLE BOARD LAYOUT

DSG0008A

WSON - 0.8 mm max height

PLASTIC SMALL OUTLINE - NO LEAD



LAND PATTERN EXAMPLE
SCALE:20X

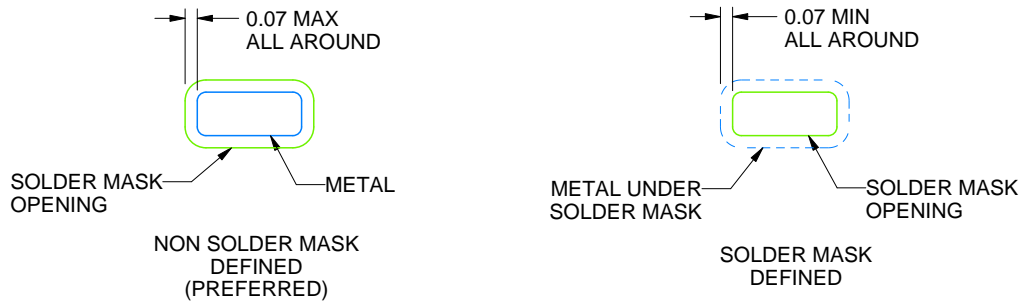

SOLDER MASK DETAILS

4218900/E 08/2022

NOTES: (continued)

4. This package is designed to be soldered to a thermal pad on the board. For more information, see Texas Instruments literature number SLUA271 (www.ti.com/lit/slua271).
5. Vias are optional depending on application, refer to device data sheet. If any vias are implemented, refer to their locations shown on this view. It is recommended that vias under paste be filled, plugged or tented.

EXAMPLE STENCIL DESIGN

DSG0008A

WSON - 0.8 mm max height

PLASTIC SMALL OUTLINE - NO LEAD



SOLDER PASTE EXAMPLE
BASED ON 0.125 mm THICK STENCIL

EXPOSED PAD 9:
87% PRINTED SOLDER COVERAGE BY AREA UNDER PACKAGE
SCALE:25X

4218900/E 08/2022

NOTES: (continued)

6. Laser cutting apertures with trapezoidal walls and rounded corners may offer better paste release. IPC-7525 may have alternate design recommendations.

重要声明和免责声明

TI“按原样”提供技术和可靠性数据（包括数据表）、设计资源（包括参考设计）、应用或其他设计建议、网络工具、安全信息和其他资源，不保证没有瑕疵且不做任何明示或暗示的担保，包括但不限于对适销性、某特定用途方面的适用性或不侵犯任何第三方知识产权的暗示担保。

这些资源可供使用 TI 产品进行设计的熟练开发人员使用。您将自行承担以下全部责任：(1) 针对您的应用选择合适的 TI 产品，(2) 设计、验证并测试您的应用，(3) 确保您的应用满足相应标准以及任何其他功能安全、信息安全、监管或其他要求。

这些资源如有变更，恕不另行通知。TI 授权您仅可将这些资源用于研发本资源所述的 TI 产品的应用。严禁对这些资源进行其他复制或展示。您无权使用任何其他 TI 知识产权或任何第三方知识产权。您应全额赔偿因在这些资源的使用中对 TI 及其代表造成的任何索赔、损害、成本、损失和债务，TI 对此概不负责。

TI 提供的产品受 [TI 的销售条款](#) 或 [ti.com](#) 上其他适用条款/TI 产品随附的其他适用条款的约束。TI 提供这些资源并不会扩展或以其他方式更改 TI 针对 TI 产品发布的适用的担保或担保免责声明。

TI 反对并拒绝您可能提出的任何其他或不同的条款。

邮寄地址：Texas Instruments, Post Office Box 655303, Dallas, Texas 75265

Copyright © 2022，德州仪器 (TI) 公司