

TS3A227E 车用音频附件检测和配置开关

1 特性

- 电源电压范围为 2.5V 至 4.5V
- 具有防反跳可调定时功能的附件插入/移除检测
- 附件配置检测：
 - 立体声 3 孔耳机
 - 麦克风 (MIC) 连接 Sleeve 的 4 孔标准耳机
 - MIC 连接 Ring2 的 4 孔国际标准 (OMTP) 耳机
- 可对多达 4 个按键进行按压检测
- 超低接地场效应晶体管 (FET) 导通电阻 R_{ON} ，仅为 60m Ω
- 断电后可消除噪声
- 隔离音频插孔的麦克风偏置电压 (MICBIAS)，消除卡嗒/爆裂噪音
- 集成编解码器感测线路
- 手动 I²C 控制
- 调频 (FM) 传输能力
- 两种小型封装选项
 - 16 引脚芯片尺寸球状引脚栅格阵列 (DSBGA) 封装
 - 16 引脚四方扁平无引线 (QFN) 封装

2 应用范围

- 移动电话
- 平板电脑
- 笔记本电脑和超级本
- 使用 3.5mm 音频接口的任意应用

4 简化电路原理图

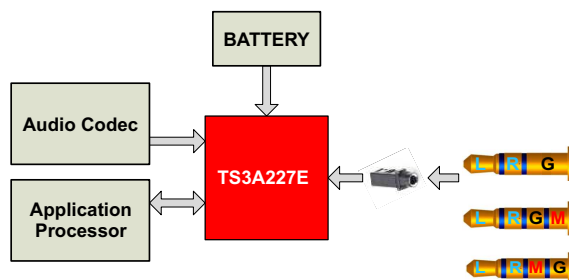

3 说明

TS3A227E 是一款音频附件自主检测和配置开关，用于检测 3 孔或 4 孔音频附件并配置内部开关，以便进行信号传输。

TS3A227E 的内部接地 FET 具有 60m Ω 超低 R_{ON} ，能够最大限度地减少串扰影响。接地 FET 也可用于传送 FM 信号，因此，可以使用附件的接地线作为移动音频应用中的 FM 天线。

利用内部隔离开关，TS3A227E 可以消除插入或移除音频附件时可能产生的卡嗒/爆裂噪音。此外，器件中的耗尽型 FET 可防止器件未通电时出现悬空接地，并防止将附件插入未通电系统时产生嗡嗡声。

当没有插入耳机时，低功耗睡眠模式可将部分内部电路关断，以实现极低的静态电流和功耗。

TS3A227E 具有集成按键按压检测功能，最多可检测 4 个按键的按压和释放操作。

手动 I²C 控制可控制防反跳设置和开关状态，从而使 TS3A227E 适应应用需求。

器件信息⁽¹⁾

器件型号	封装	封装尺寸 (标称值)
TS3A227E	QFN (16)	3.50mm x 3.50mm
	DSBGA (16)	1.79mm x 1.79mm

(1) 要了解所有可用封装，请见数据表末尾的可订购产品附录。



目录

1	特性	1	9.2	Functional Block Diagram	18
2	应用范围	1	9.3	Feature Description	19
3	说明	1	9.4	Device Functional Modes	20
4	简化电路原理图	1	9.5	Register Maps	24
5	修订历史记录	2	9.6	Register Field Descriptions	24
6	Pin Configuration and Functions	3	10	Application and Implementation	33
7	Specifications	4	10.1	Application Information	33
7.1	Absolute Maximum Ratings	4	10.2	Typical Application	33
7.2	ESD Ratings	4	11	Power Supply Recommendations	47
7.3	Recommended Operating Conditions	5	12	Layout	48
7.4	Thermal Information	5	12.1	Layout Guidelines	48
7.5	Electrical Characteristics	6	12.2	Layout Example (QFN)	48
7.6	I ² C Interface Timing Characteristics	8	12.3	Layout Example (DSBGA)	49
7.7	Timing Diagrams	9	13	器件和文档支持	50
7.8	Typical Characteristics	12	13.1	商标	50
8	Parameter Measurement Information	12	13.2	静电放电警告	50
9	Detailed Description	17	13.3	术语表	50
9.1	Overview	17	14	机械封装和可订购信息	50

5 修订历史记录

Changes from Revision A (December 2014) to Revision B	Page
• Added DSBGA package to the Thermal Information table.	5
• Updated SWITCH RESISTANCE for the DSBGA package.	6

Changes from Original (July 2014) to Revision A	Page
• 最初发布的完整版文档。	1

6 Pin Configuration and Functions

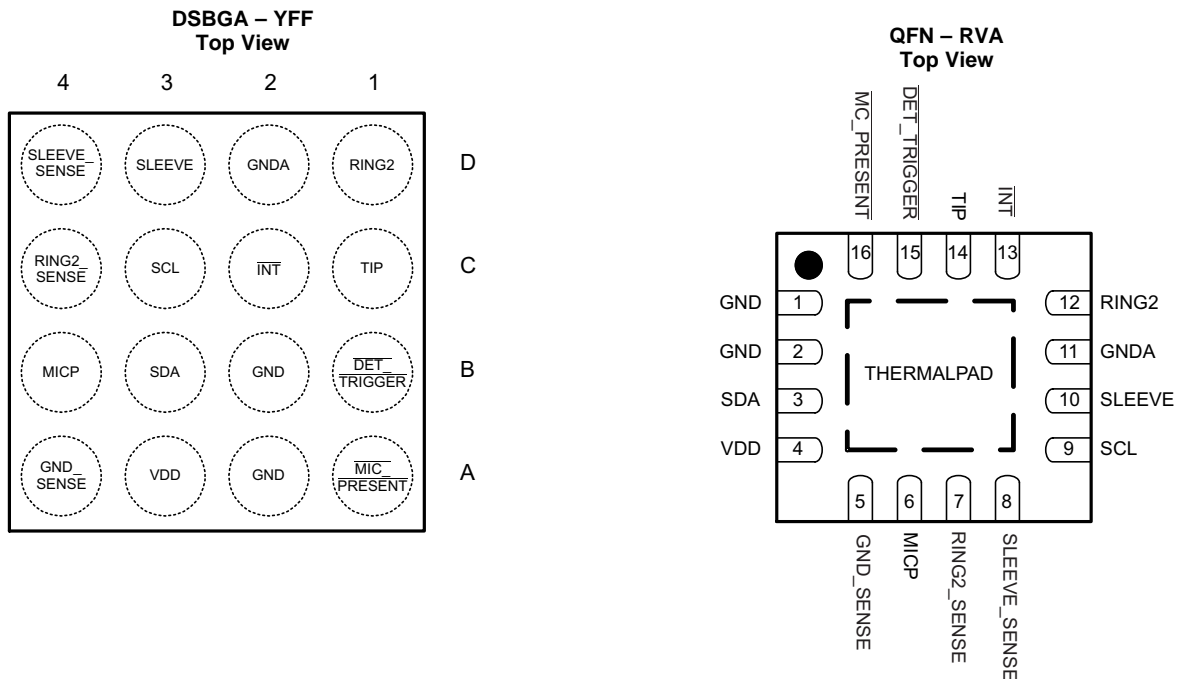

Pin Functions

PIN			TYPE	DESCRIPTION
NAME	RVA	YFF		
$\overline{\text{DET_TRIGGER}}$	15	B1	I/O	A falling edge from high to low on this pin triggers accessory detection. This pin can be connected the headset jack to allow automatic pull-down to ground after headset insertion to initialize detection.
GND	1, 2	A2, B2	GND	Primary ground connection for the TS3A227E. Must be connected to system ground.
GNDA	11	D2	I/O	Ground connection for the internal ground FETs of the TS3A227E. If FM is being supported connect this pin to the FM matching network. If FM is not being support connect this pin to system ground.
GND_SENSE	5	A4	I/O	Ground sense line for the codec.
$\overline{\text{INT}}$	13	C2	GND	Open drain interrupt output from the TS3A227E to notify the host that an event has occurred. If I ² C is not used this pin must be grounded.
$\overline{\text{MIC_PRESENT}}$	16	A1	I/O	Open drain output to indicate to the host that a headset with a microphone is inserted..
MICP	6	B4	I/O	Microphone signal connection to the codec. Microphone bias is applied to this pin.
RING2	12	D1	O	Headset current return path if RING2 is ground for the headset. Connect to 3.5 mm jack RING2 connection with low DC resistance trace.
RING2_SENSE	7	C4	GND	Connected to the RING2 pin of the 3.5 mm jack. If RING2 pin on plug in is MIC signal, this is connected to MICP. If not, this is connected to GND_SENSE and becomes the ground sensing feedback for the accessory
SCL	9	C3	I	Clock from I ² C bus. This can be connected to VDD if I ² C is not used.
SDA	3	B3	I/O	Bidirectional data from/to I ² C bus. This can be connected to VDD if I ² C is not used.
SLEEVE	10	D3	O	Headset current return path if SLEEVE is GND for headset. Connect to 3.5 mm jack SLEEVE connection with low DC resistance trace.
SLEEVE_SENSE	8	D4	GND	Connected to the SLEEVE pin of the 3.5 mm jack. If SLEEVE pin on plug in is MIC signal, this is connected to MICP. If not, this is connected to GND_SENSE and becomes the ground sensing feedback for the accessory
THERMAL PAD			GND	The THERMAL PAD of the RVA – QFN package must be connected to any internal PCB ground plane using multiple vias for best thermal performance.
TIP	14	C1	I/O	Connect to the TIP pin of the 3.5 mm jack.
VDD	4	A3	PWR	Power input to the TS3A227E. External de-coupling capacitors are required on this pin.

7 Specifications

7.1 Absolute Maximum Ratings

over operating free-air temperature range referenced with respect to GND (unless otherwise noted)⁽¹⁾

		MIN	MAX	UNIT
Input Voltage	VDD	-0.3	5	V
	SDA, SCL, INT, MIC_PRESENT	-0.3	V _{DD} + 0.5	V
	TIP	-3.3	V _{DD} + 0.5	V
	DET_TRIGGER	-2.2	V _{DD} + 0.5	V
	GND_SENSE, RING2, SLEEVE, RING2_SENSE, SLEEVE_SENSE, MICP, GNDA	-0.3	3.6 ⁽²⁾ and V _{DD} + 0.5	V
ON-state switch current	Combined continuous current through R2GNDFET and SLV GNDFET		500	mA
	Continuous current through R2DFET and SLV DFET		50	
	Continuous current through S1		20	
	Continuous current through S2		20	
	Continuous current through S3PR		50	
	Continuous current through S3PS		50	
	Continuous current through S3GR		100	
	Continuous current through S3GS		100	
Operating ambient temperature range		-40	85	°C
T _{stg}	Storage temperature range	-65	150	°C

(1) Stresses beyond those listed under *Absolute Maximum Ratings* may cause permanent damage to the device. These are stress ratings only, which do not imply functional operation of the device at these or any other conditions beyond those indicated under *Recommended Operating Conditions*. Exposure to absolute-maximum-rated conditions for extended periods may affect device reliability.

(2) This rating is exclusive and the voltage on the pins must not exceed either 3.6 and V_{DD}. E.g. if V_{DD} = 4.5 V the voltage on the pin must not exceed 3.6 V and if V_{DD} is = 2.5 V the voltage on the pin must not exceed 3.0 V.

7.2 ESD Ratings

			VALUE	UNIT
V _(ESD)	Electrostatic discharge	Human body model (HBM), ESD stress voltage new note #1 to the ESD Ratings table and combined MIN MAX column to VALUE ^{(1) (2)}	±2000	V
		Charged device model (CDM), ESD stress voltage ^{(1) (3)}	±500	V
		Contact discharge model (IEC) ESD stress voltage on TIP, DET_TRIGGER, RING2_SENSE, SLEEVE_SENSE, RING2, SLEEVE ⁽¹⁾	±8000	V

(1) Electrostatic Discharge (ESD) to measure device sensitivity and immunity to damage caused by assembly line electrostatic discharges into the device

(2) JEDEC document JEP155 states that 500-V HBM allows safe manufacturing with a standard ESD control process.

(3) JEDEC document JEP157 states that 250-V CDM allows safe manufacturing with a standard ESD control process.

7.3 Recommended Operating Conditions

over operating free-air temperature range (unless otherwise noted)

		MIN	MAX	UNIT
V _{DD}	Power supply voltage range	2.5	4.5	V
V _I	Digital input voltage range	SDA, SCL	V _{DD}	V
		DET_TRIGGER	V _{DD}	V
V _{IO}	Input/output voltage range	RING2_SENSE, SLEEVE_SENSE, RING2, SLEEVE, GND_SENSE, MICP	3.3 ⁽¹⁾ and V _{DD}	V
		TIP	V _{DD}	V
V _O	Output voltage range	0	V _{DD}	V
V _{IH}	Input logic high	SDA, SCL	V _{DD}	V
		DET_TRIGGER	0.65 × V _{DD}	V
V _{IL}	Input logic low	SDA, SCL	0.4	V
		DET_TRIGGER	0.4 × V _{DD}	V
T _A	Operating ambient temperature	–40	85	°C

(1) This rating is exclusive and the voltage on the pins must not exceed either 3.3 and V_{DD}. E.g. if V_{DD} = 4.5 V the voltage on the pin must not exceed 3.3 V and if V_{DD} is = 2.5 V the voltage on the pin must not exceed 2.5 V.

7.4 Thermal Information

THERMAL METRIC ⁽¹⁾		TS3A227E	TS3A227E	UNIT
		RTE	YFF	
		16 PINS	16 PINS	
R _{θJA}	Junction-to-ambient thermal resistance	45.9	77.9	°C/W
R _{θJC(top)}	Junction-to-case (top) thermal resistance	52.6	0.6	
R _{θJB}	Junction-to-board thermal resistance	21.2	12.5	
ψ _{JT}	Junction-to-top characterization parameter	0.9	2.3	
ψ _{JB}	Junction-to-board characterization parameter	21.2	12.5	
R _{θJC(bot)}	Junction-to-case (bottom) thermal resistance	4.3	-	

(1) For more information about traditional and new thermal metrics, see the *IC Package Thermal Metrics* application report, [SPRA953](#).

7.5 Electrical Characteristics

Unless otherwise noted the specification applies over the VDD and ambient operating temperature range.

PARAMETER		TEST CONDITIONS	MIN	TYP	MAX	UNIT		
SUPPLY VOLTAGE								
VDD	Supply voltage		2.5	3.3	4.5	V		
I _{DD}	Quiescent current	No accessory inserted. I ² C bus inactive ⁽¹⁾ V _{DD} = 2.5 V to 4.5 V		0.5	10	μA		
		Manual switch control = '1', I ² C bus inactive, ⁽¹⁾ V _{DD} = 2.5 V to 4.5 V, Depletion FETs on		7	15	μA		
		Manual switch control = '1', I ² C bus inactive, V _{DD} = 2.5 V to 4.5 V Depletion FETs off		20	40	μA		
		3-pole accessory inserted. I ² C bus inactive ⁽¹⁾ , FM Support = '0' V _{DD} = 2.5 V to 4.5 V		11	20	μA		
		3-pole accessory inserted. I ² C bus inactive, ⁽¹⁾ FM Support = '1' V _{DD} = 2.5 V to 4.5 V		25	45	μA		
		4-pole Accessory inserted. I ² C bus inactive, ⁽¹⁾ V _{DD} = 2.5 V to 4.5 V		25	40	μA		
		4-pole Accessory inserted. KP detection enabled I ² C bus inactive, ⁽¹⁾ V _{DD} = 2.5 V to 4.5 V		30	45	μA		
I _{DD_1.8}	Quiescent current addition from using a 1.8 V I2C bus. ⁽²⁾	No accessory inserted. I ² C bus inactive at 1.8 V, ⁽³⁾ V _{DD} = 2.5 V to 4.5 V		1	8	μA		
SWITCH RESISTANCE								
R _{R2GNDFT}	RING2 GNDFET on resistance (DSBGA Package)	V _{DD} = 3.3 V, V _{GND} = 0V, I _{GND_A} = 75 mA		40	85	mΩ		
	RING2 GNDFET on resistance (QFN Package)			60	95			
R _{SLVGNDFT}	SLEEVE GNDFET on resistance (DSBGA Package)			40	85			
	SLEEVE GNDFET on resistance (QFN Package)			60	95			
R _{S3PS}	S3PS on resistance		V _{DD} = 3.3 V, V _{SLEEVE_SENSE/RING2_SENSE} = 0 V to 2.7 V, I _{MICP} = ±10 mA		3		6.5	Ω
R _{S3PR}	S3PR on resistance				3		6.5	
R _{S3GS}	S3GS on resistance	V _{DD} = 3.3 V, V _{SLEEVE_SENSE/RING2_SENSE} = 0 V to 2.7 V, I _{GND_SENSE} = ±75 mA		0.5	1	Ω		
R _{S3GR}	S3GR on resistance			0.5	1			
R _{S1}	Switch 1 on resistance	V _{DD} = 3.3 V, I _{GND} = 10 mA		15	30	Ω		
R _{S2}	Switch 2 on resistance			15	30			
R _{R2DFET}	RING2 depletion FET on resistance				75	150	Ω	
R _{SLVDFET}	SLEEVE depletion FET on resistance				75	150		
SWITCH LEAKAGE CURRENT								
I _{OFF}	RING2 pin off leakage	V _{IN} = 0 V to 3.3 V, V _{DD} = 3.3 V			1	μA		
	SLEEVE pin off leakage				1			
	RING2_SENSE pin off leakage				1			
	SLEEVE_SENSE pin off leakage				1			
	MICP pin off leakage				1			
	GND_SENSE pin off leakage				1			
I _{ON}	S2PS, S3PR, S3GS, S3GR on leakage	V _{SLEEVE/RING2} = 0V, V _{DD} = 3.3 V			1	μA		

(1) The I²C bus is inactive if both the SDA and SCL lines are tied to V_{DD}.

(2) If the I²C bus is operating at 1.8 V the I_{DD_1.8} current number will be in addition to the other current consumption numbers specified.

(3) The I²C bus is inactive if both the SDA and SCL lines are tied to 1.8 V.

Electrical Characteristics (continued)

Unless otherwise noted the specification applies over the VDD and ambient operating temperature range.

PARAMETER		TEST CONDITIONS	MIN	TYP	MAX	UNIT
SWITCH TIMING						
t _{OFF}	Turn off time for S3PS, S3PR, S3GS, S3GR	V _{DD} = 2.5 V, 3.3 V, 4.5 V, R _L = 300 Ω, C _L = 50 pF V _{SLEEVE_SENSE/RING2_SENSE} = 2.5 V (V _{DD} = 2.5 V), 3.3 V (V _{DD} = 3.3 V, V _{DD} = 4.5 V)			5	μs
	Turn off time for S1, S2, RING2 GDNFET, SLEEVE GDNFET	V _{DD} = 2.5 V, 3.3 V, 4.5 V R _{PU} = 1500 Ω, C _L = 50 pF V _{PU} = 2.5 V (V _{DD} = 2.5 V), 3.3 V (V _{DD} = 3.3 V, V _{DD} = 4.5 V)			5	μs
	Turn off time for RING2 DFET and SLEEVE DFET	V _{DD} = 2.5 V, 3.3 V, 4.5 V R _{PU} = 1500 Ω, C _L = 50 pF V _{PU} = 2.5 V (V _{DD} = 2.5 V), 3.3 V (V _{DD} = 3.3 V, V _{DD} = 4.5 V)			500	μs
t _{ON}	Turn on time for S3PS, S3PR, S3GS, S3GR	V _{DD} = 2.5 V, 3.3 V, 4.5 V R _L = 300 Ω, C _L = 50 pF V _{SLEEVE_SENSE/RING2_SENSE} = 2.5 V (V _{DD} = 2.5 V), 3.3 V (V _{DD} = 3.3 V, V _{DD} = 4.5 V)			1	μs
	Turn on time for S1, S2, RING2 GDNFET, SLEEVE GDNFET	V _{DD} = 2.5 V, 3.3 V, 4.5 V R _{PU} = 1500 Ω, C _L = 50 pF V _{PU} = 2.5 V (V _{DD} = 2.5 V), 3.3 V (V _{DD} = 3.3 V, V _{DD} = 4.5 V)			35	μs
	Turn on time for RING2 DFET and SLEEVE DFET	V _{DD} = 2.5 V, 3.3 V, 4.5 V R _{PU} = 1500 Ω, C _L = 50 pF V _{PU} = 2.5 V (V _{DD} = 2.5 V), 3.3 V (V _{DD} = 3.3 V, V _{DD} = 4.5 V)			1	μs
DIGITAL I/O						
V _{OL}	MIC_PRESENT low level output voltage	V _{DD} = 3.3 V, I _{OL} = 10 mA	0		0.4	V
	INT low level output voltage		0		0.4	
	SDA low level output voltage		0		0.4	
V _{IH}	Input logic high	SDA, SCL	1.2		V _{DD}	V
		DET_TRIGGER	V _{DD} × 0.65		V _{DD}	
V _{IL}	Input logic low	SDA, SCL	0		0.4	
		DET_TRIGGER	0		V _{DD} × 0.4	
R _{PU/DT}	Internal DET_TRIGGER pull-up resistance	V _{DD} = 3.3 V, I _{DET_TRIGGER} = 1 μA	0.5	1	1.85	MΩ

Electrical Characteristics (continued)

Unless otherwise noted the specification applies over the VDD and ambient operating temperature range.

PARAMETER		TEST CONDITIONS	MIN	TYP	MAX	UNIT
DYNAMIC CHARACTERISTICS						
PSR ₂₁₇	Power supply rejection	V _{DD} = 3.3 V ± 200 mV _{PP} , f = 217 Hz, R _L at RING2= 50 Ω	-95	-120		dB
PSR _{1k}		V _{DD} = 3.3 V ± 200 mV _{PP} , f = 1 kHz, R _L at RING2= 50 Ω	-85	-110		
PSR _{20k}		V _{DD} = 3.3 V ± 200 mV _{PP} , f = 20 kHz, R _L at RING2= 50 Ω	-70	-90		
ISO _{S3}	SLEEVE_SENSE or RING2_SENSE to MICP Isolation	V _{IN} = 200 mV _{PP} , f = 20 Hz – 20 kHz, R _L = 50 Ω		-90		dB
SEP _{S3}	SLEEVE_SENSE to RING2_SENSE Separation	V _{IN} = 200 mV _{PP} , f = 20 Hz – 20 kHz, R _L = 50 Ω		-75		dB
BW	Bandwidth through GNDFETs	V _{IN} = 60 mV _{PP} , I _{BIAS} = 10 mA	120	150		MHz
THD ₂₀₀	MICP to RING2_SENSE or SLEEVE_SENSE total harmonic distortion	V _{IN} = 1.5 V + 200 mV _{PP} , f = 20 Hz – 20 kHz, R _S = 600 Ω, R _L = 600 Ω		0.003 %		
THD ₅₀₀		V _{IN} = 1.5 V + 500 mV _{PP} , f = 20 Hz – 20 kHz, R _S = 600 Ω, R _L = 600 Ω		0.002%		
SNR	MICP to RING2_SENSE or SLEEVE_SENSE signal to noise ratio	V _{IN} = 1 V _{RMS} , f = 20 Hz – 20 kHz, R _S = 600 Ω, R _L = 600 Ω	-90	-110		dB
t _{DET}	Detection sequence duration	Time between DET_TRIGGER transition from high to low and INT transition from high to low. Default 90 ms insertion debounce.		175	210	ms
T _{power-up}	Power up time Power-up time	Time from V _{DD} > 2.5 V till I ² C communication is ready		20	25	ms
t _{REMOVAL}	Removal wait period	Time between DET_TRIGGER transition from low to high and RING2/SLEEVE DFETs turning on		50	65	ms

7.6 I²C Interface Timing Characteristics

Unless otherwise noted the specification applies over the VDD and ambient operating temperature range

PARAMETER		STANDARD MODE I ² C BUS		FAST MODE I ² C BUS		UNIT
		MIN	MAX	MIN	MAX	
f _{scl}	I ² C clock frequency	0	100	0	400	kHz
t _{sch}	I ² C clock high time	4		0.6		μs
t _{scl}	I ² C clock low time	4.7		1.3		μs
t _{sp}	I ² C spike time		50		50	ns
t _{sds}	I ² C serial data setup time	250		100		ns
t _{sdh}	I ² C serial data hold time	0		0		ns
t _{icr}	I ² C input rise time		1000	21	300	ns
t _{icf}	I ² C input fall time		300	21	300	ns
t _{ocf}	I ² C output fall time; 10 pF to 400 pF bus		300	20 + 0.1 C _b	300	μs
t _{buf}	I ² C bus free time between Stop and Start	4.7		1.3		μs
t _{sts}	I ² C Start or repeater Start condition setup time	4.7		0.6		μs
t _{sth}	I ² C Start or repeater Start condition hold time	4		0.6		μs
t _{sps}	I ² C Stop condition setup time	4		0.6		μs
t _{vd(data)}	Valid data time; SCL low to SDA output valid		3.45	0.3	0.9	μs
t _{vd(ack)}	Valid data time of ACK condition; ACK signal from SCL low to SDA (out) low		3.45	0.3	0.9	μs
C _b	I ² C bus capacitive loading	0	400	0	400	pF

7.7 Timing Diagrams

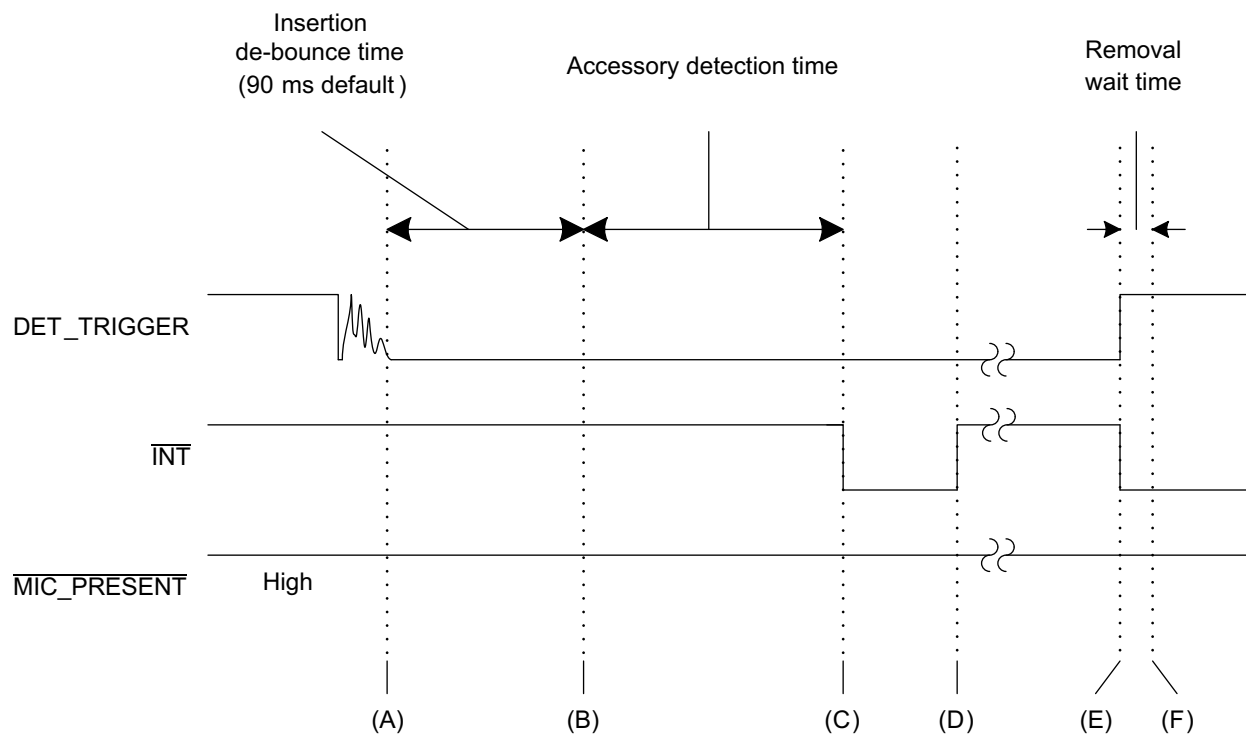

- A. (This is the point that $\overline{\text{DET_TRIGGER}}$ has stopped glitching and is fully low. The de-bounce time of 90 ms starts from the point that the pin is constantly below the V_{IL} level. Any time the $\overline{\text{DET_TRIGGER}}$ pin cross the V_{IH} level the de-bounce timer will restart.
- B. Point B is the end of the insertion de-bounce time and the beginning of accessory detection.
- C. Detection has completed at this point. The switches will be routed before the $\overline{\text{INT}}$ pin is pulled low.
- D. $\overline{\text{INT}}$ is cleared after the host reads the interrupt register.
- E. The headset is removed here. The switch states will change immediately and $\overline{\text{INT}}$ will be pulled low.
- F. After a 50 ms removal de-bounce timer the TS3A227E will go back into sleep mode if manual switch control is not enabled

图 1. 3-Pole Accessory

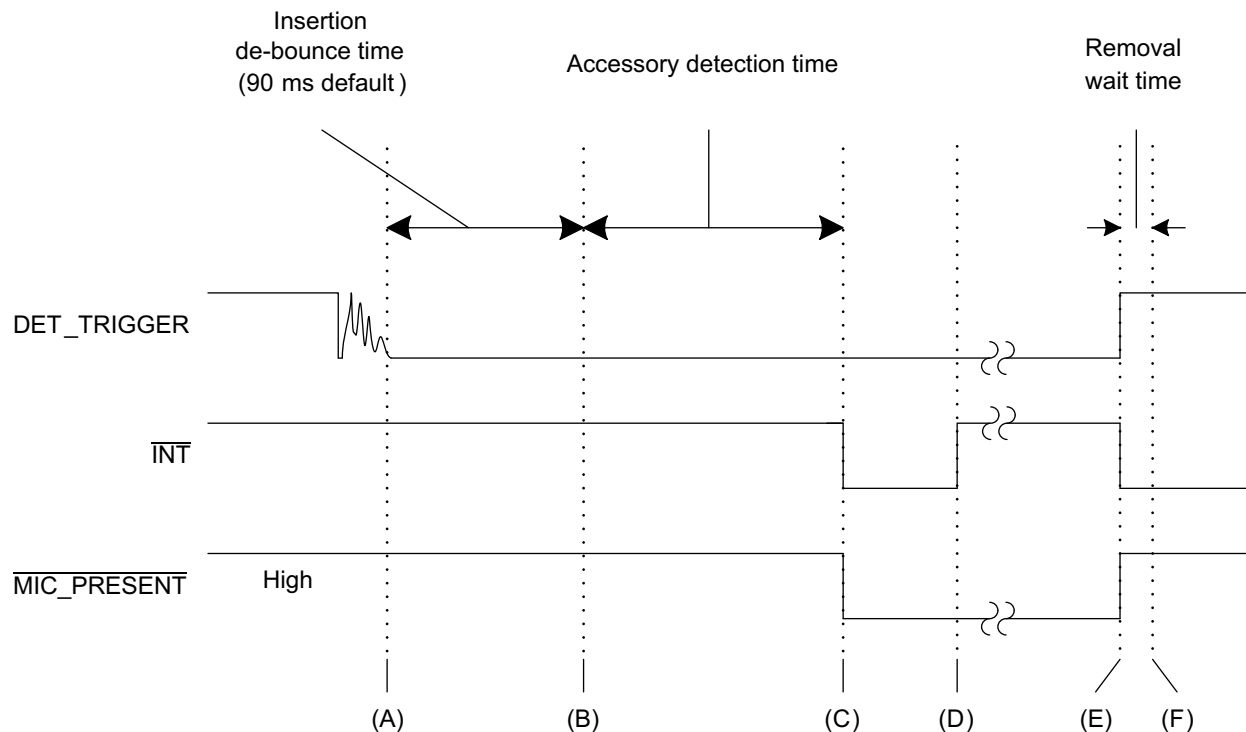
Timing Diagrams (接下页)

- A. This is the point that DET_TRIGGER has stopped glitching and is fully low. The de-bounce time of 90 ms starts from the point that the pin is constantly below the V_{IL} level. Any time the DET_TRIGGER pin cross the V_{IH} level the de-bounce timer will restart.
- B. Point B is the end of the insertion de-bounce time and the beginning of accessory detection.
- C. Detection has completed at this point. The switches will be routed before the INT and MIC_PRESENT pins are pulled low.
- D. INT is cleared after the host reads the interrupt register.
- E. The headset is removed here. The switch states will change immediately and INT will be pulled low. The MIC_PRESENT pin will be released.
- F. After a 50 ms removal de-bounce timer the TS3A227E will go back into sleep mode if manual switch control is not enabled

图 2. 4-Pole Accessory

Timing Diagrams (接下页)

7.7.1 Removal

A removal event will interrupt any on-going process in the TS3A227E. The following diagram depicts how the device “jumps” during a removal.

If the removal event occurs during the insertion de-bounce period the TS3A227E will jump to the (A) point of the diagram depicted by the green arrow and line.

Any time after point (B) has been reached and the accessory is removed the device jumps to point (E), which includes key press detection. Under Manual Switch Control the switch states will not change.



图 3. Removal Timing During Insertion

7.8 Typical Characteristics

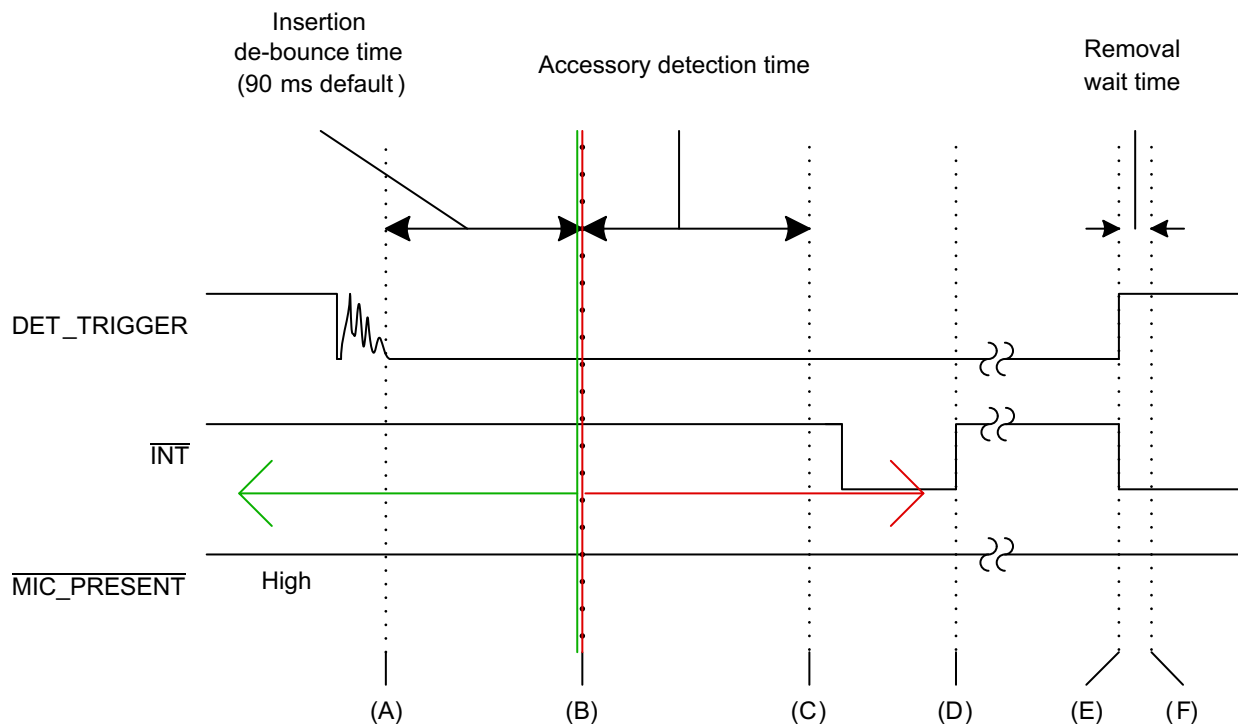
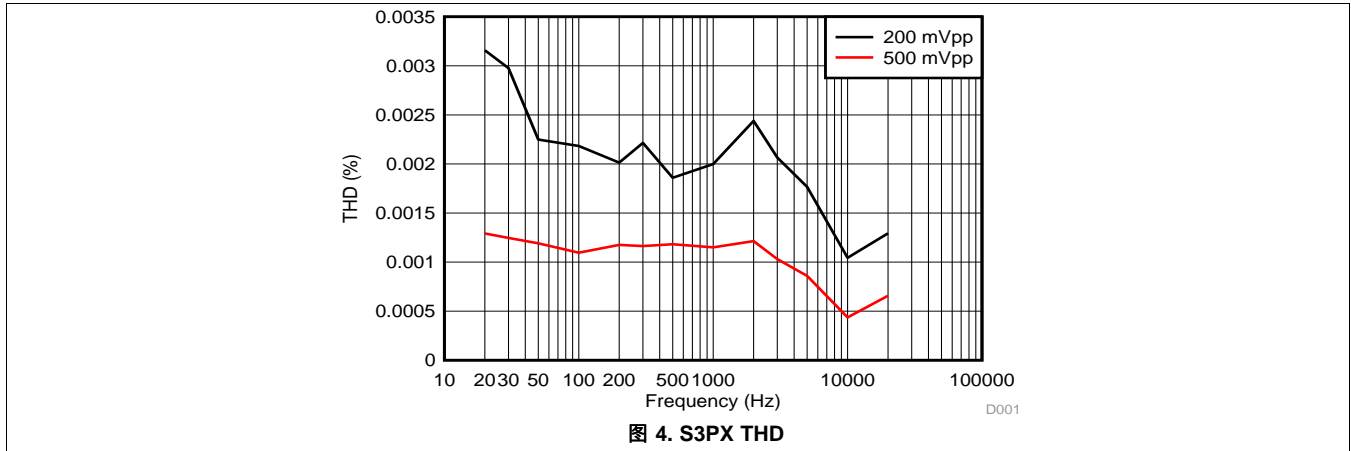

8 Parameter Measurement Information

Channel ON
 $R_{ON} = V_{SLEEVE/RING2} / I_{GNDA}$



图 5. RING2/SLEEVE GNDFET On Resistance Measurement

Channel ON
 $R_{ON} = V_{SLEEVE/RING2} / I_{GND}$

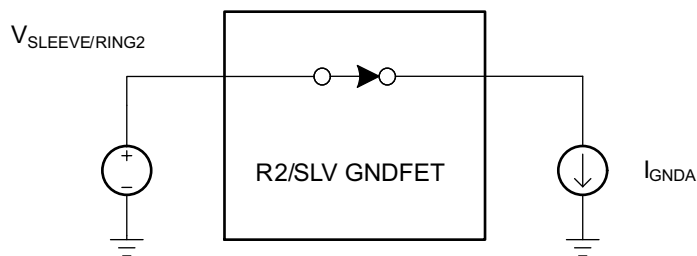

图 6. RING2/SLEEVE DFET On Resistance Measurement

Parameter Measurement Information (接下页)

Channel ON
 $R_{ON} = V_{MICP/GND_SENSE} / I_{GND}$

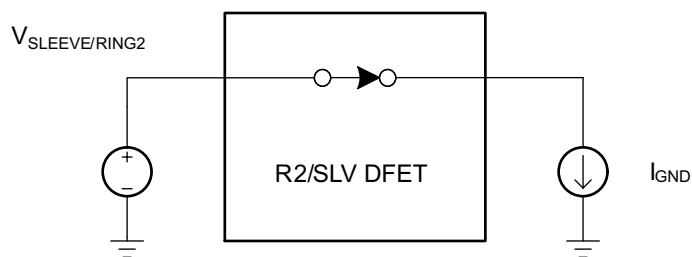

图 7. S1/S2 On Resistance Measurement

Channel ON
 $R_{ON} = V_{MICP/GND_SENSE} / I_{RING2_SENSE/SLEEVE_SENSE}$

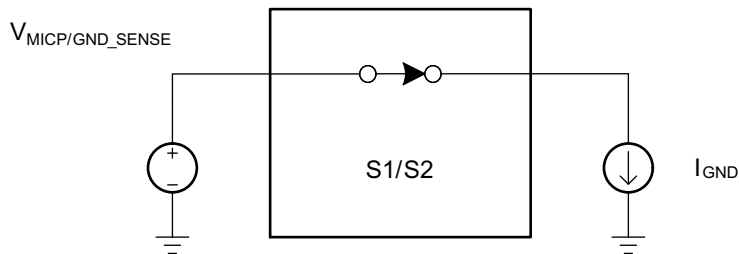

图 8. S3PS, S3PR, S3GS, S3GR On Resistance Measurement

Channel OFF

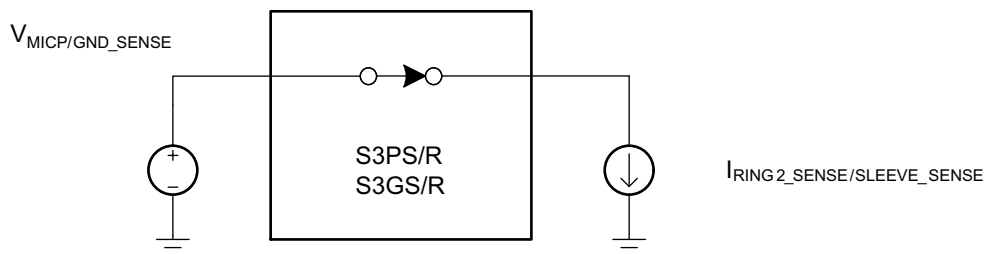

图 9. Switch Off Leakage Current

Parameter Measurement Information (接下页)

Channel ON

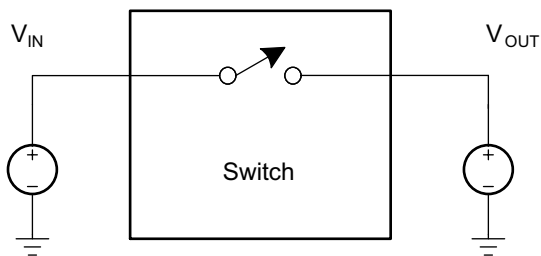

图 10. Switch On Leakage Current

Channel ON

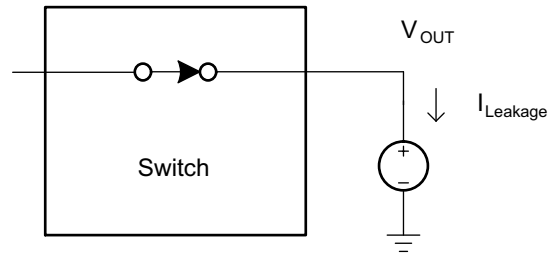

图 11. Power Supply Rejection Ratio (PSRR)

Channel Off

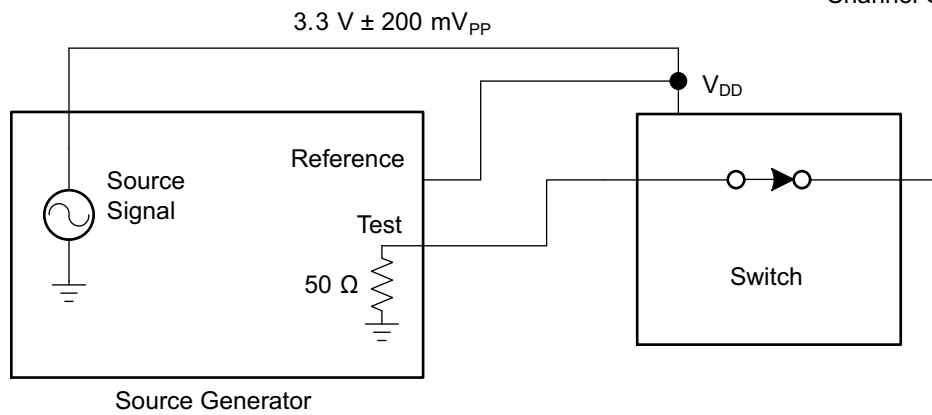

图 12. Switch Off Isolation

Parameter Measurement Information (接下页)



图 13. Channel Separation

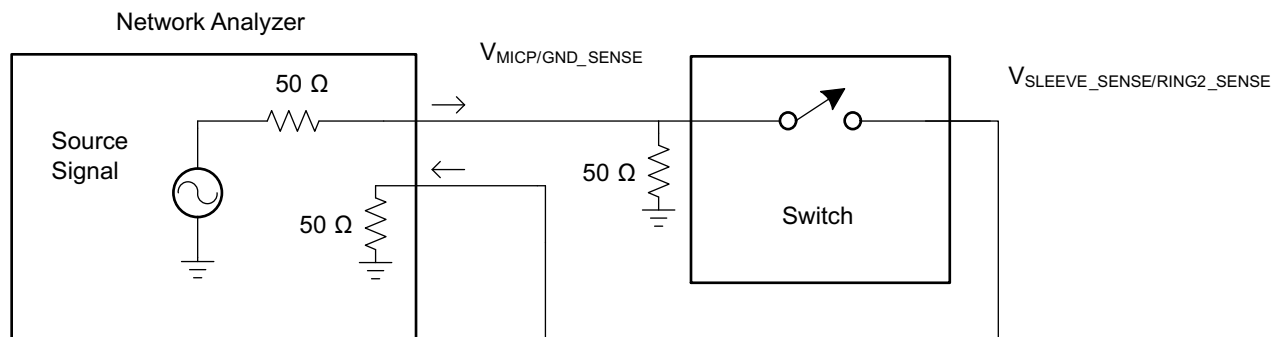

图 14. Total Harmonic Distortion (THD) and SNR

Parameter Measurement Information (接下页)

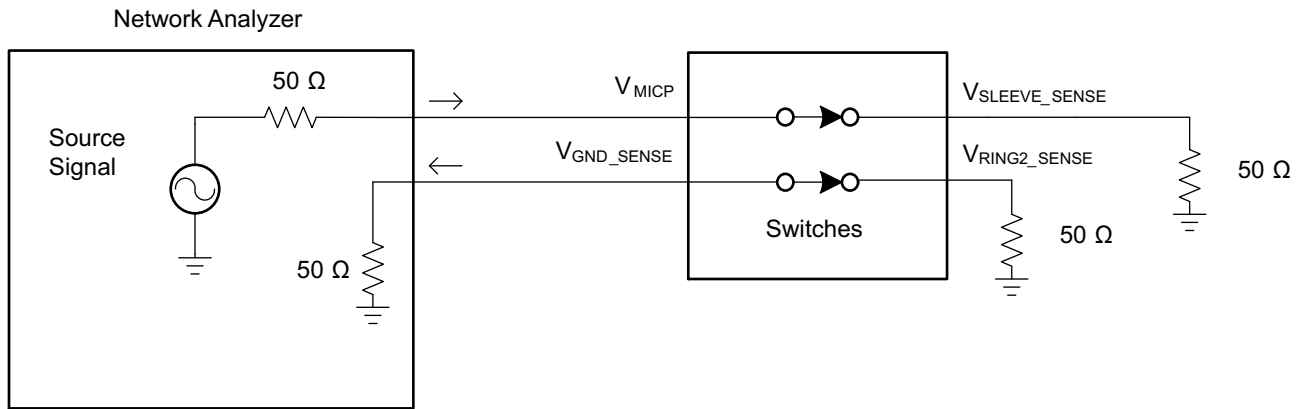

图 15. S3 t_{OFF}/t_{ON}

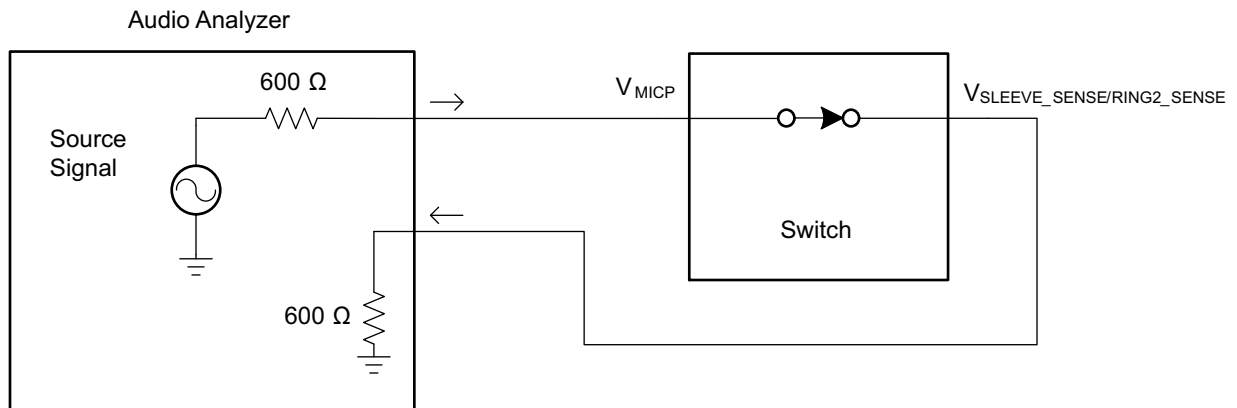

图 16. S1, S2, GNDFET and DFET t_{ON}/t_{OFF}

9 Detailed Description

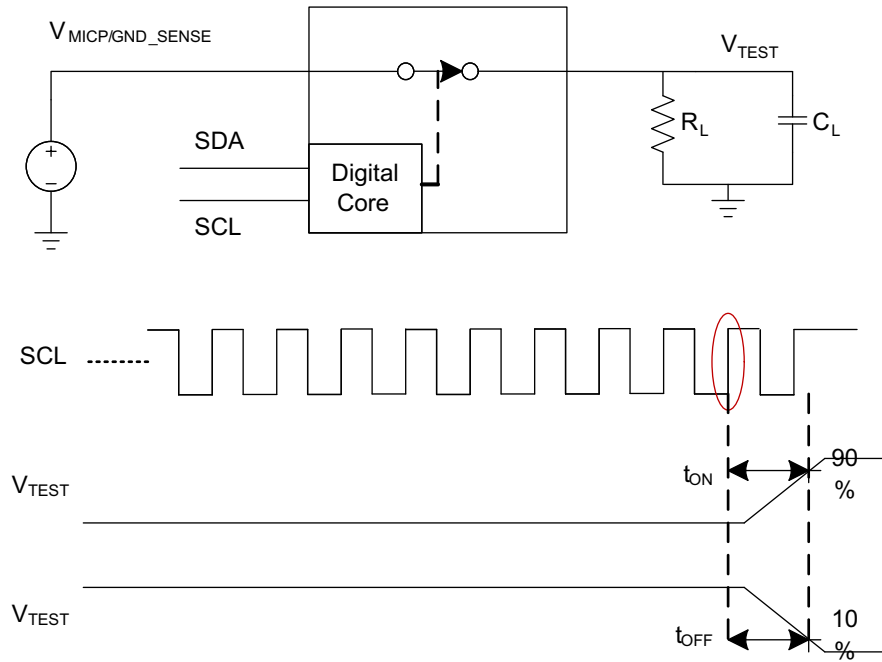
9.1 Overview

The TS3A227E is an autonomous audio accessory switch with adjustable de-bounce settings, ultra-low RON ground FETs, depletion FETs and manual I²C control.

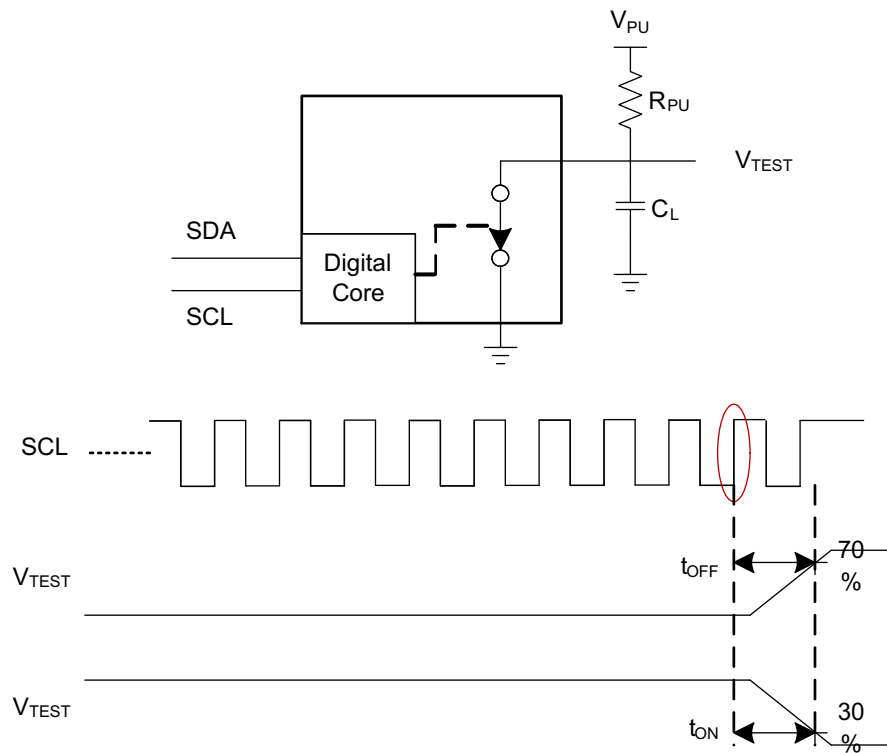
The detection sequence is initiated via the external $\overline{\text{DET_TRIGGER}}$ pin or via I2C command. The device incorporates internal de-bounce timings that remove the need for external RC circuits, reducing cost and overall PCB footprint. Additionally all switches of the TS3A227E and the internal de-bounce timings can be controlled through I²C.

Before an insertion, TS3A227E isolates the MICBIAS voltage output from the audio jack to remove click/pop noise that can be created during an insertion event. In addition the device also includes depletion FETs to ground the accessory SLEEVE and RING2 pins when VDD is not powered. This removes the humming noise that can be created when plugging an accessory into and unpowered system.

The TS3A227E detects the presence and configuration of the microphone in an attached headset upon insertion. Upon detection of a microphone the TS3A227E automatically connects a system analog microphone pin (MICP) to the appropriate audio jack connection. The device also automatically routes the device GNDA pin to the headset ground. After a 4-pole headset insertion the host can enable the Key Press detection feature of the TS3A227E.

The device also features an ultra-low power sleep mode to conserve battery life when an accessory is not inserted.

For FM transmission the ground FETs of the device can be used as an FM transmission path by placing the FM receiver and matching network on the GNDA pin. The FM support bit must be set to '1' through I²C for FM transmission to pass.

TS3A227E

ZHCSD70B – NOVEMBER 2014 – REVISED FEBRUARY 2015

www.ti.com.cn

9.2 Functional Block Diagram

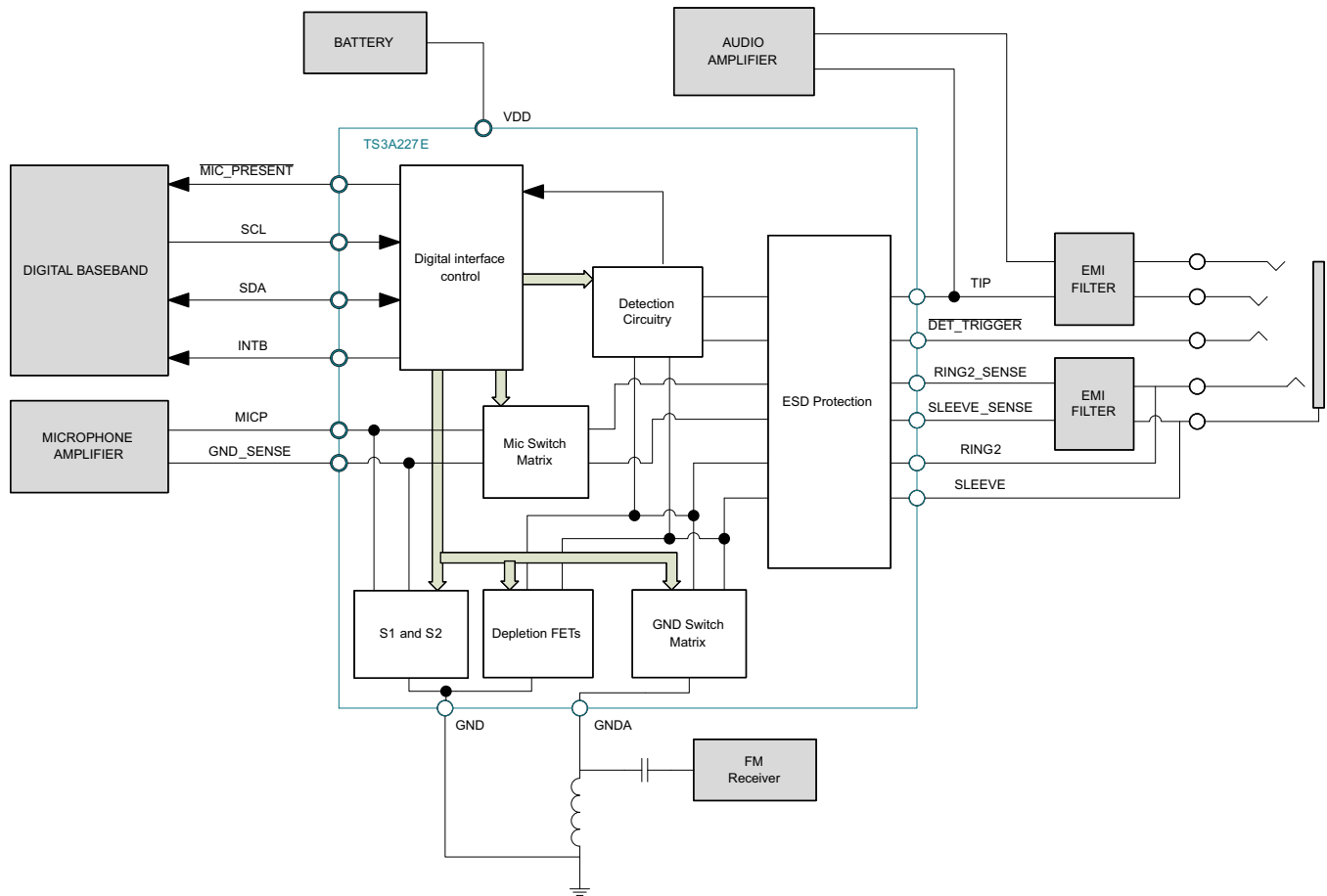

9.3 Feature Description

9.3.1 Accessory Configuration Detection

There are currently two difference configurations for headsets with microphones as shown in 表 1. Many codecs requires that the system designer make a tough decision via a hardware connection which headset they would like to support. This is done by directly connecting the microphone bias and the ground connections to the sleeve and ring2 pins of the audio jack. For the end user this leaves a headset standard as fully unsupported.

表 1. Two Difference Configurations for Headsets

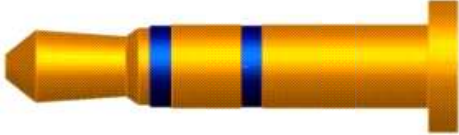
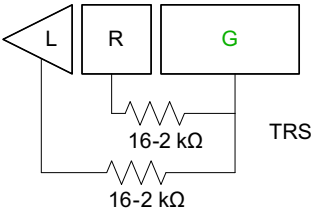
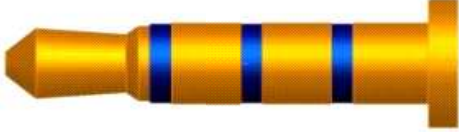
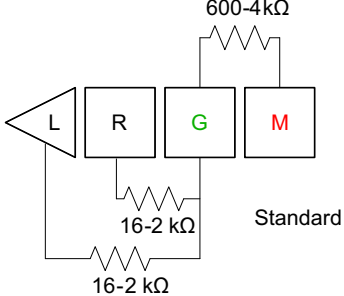
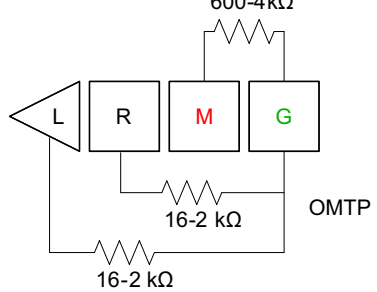
PHYSICAL CONNECTOR			INTERNAL IMPEDANCE NETWORK	PIN NAME	CONFIGURATION	
 <p>3-pole TRS</p>	Tip	Ring	 <p>TRS</p>	Tip	Audio Left	
		Sleeve		Sleeve	Ring	Audio Right
					Sleeve	Ground
 <p>4-pole TRRS</p>	Tip	Ring1	 <p>Standard</p>	Tip	Audio Left	
		Ring2		Ring1	Ring1	Audio Right
		Sleeve		Ring2	Ring2	Ground
				 <p>OMTP</p>	Sleeve	Microphone
					Tip	Audio Left
					Ring1	Audio Right
				Ring2	Microphone	
				Sleeve	Ground	

The TS3A227E fills this system gap by detecting the presence and location of the microphone and automatically routing the MICBIAS and ground lines to support each headset. This enhances the overall user experience by allowing headsets from all manufacturers.

9.3.2 Optional Manual I²C Control

The TS3227E also features optional manual I²C control for enhanced system flexibility. This allows the system designer to manually control the switches and de-bounce settings at their discretion enabling the TS3A227E to adapt to unique use cases.

This is an optional feature that does not need to be used for the device to operate autonomously.

9.3.3 Adjustable De-bounce Timings

The TS3A227E features manual control of the insertion de-bounce timer with selectable values. The default insertion de-bounce timer is 90 ms.

This eliminates the need for external RC components which reduces BOM cost, the PCB footprint of the external RC components. Further information on how to select an appropriate de-bounce timer can be found in the application and implementation section.

9.3.4 Key Press Detection

After a headset is inserted, the host can enable Key Press detection through the I²C registers. This will configure the TS3A227E to detect up to 4 different keys and report when the key is pressed and released.

9.3.5 Click Pop Noise Reduction

During an accessory insertion and removal event the TS3A227E use special techniques to remove the click/pop noise that can occur with a traditional implementation creating a better user experience.

9.3.6 Power off Noise Removal

In a system that intends to support both headset types, the end user can place the system into sleep mode and leave a headset/speaker plugged into the audio jack. If the audio jack switch is turned off to conserve power in the sleep mode this would typically mean the headset/speaker ground would not be connected because there is no power to turn on the ground FETs. This creates an audible humming noise at the speaker/headset output that can be discomfoting to listen to.

By utilizing always on depletion FETs this issue can be removed and the headset/speaker can be connected to ground even with the device unpowered.

9.3.7 Sleep Mode

The TS3A227E will automatically enter a low power sleep when no accessory is inserted and manual switch control is not enabled. After an accessory is inserted the device will wake, run detection, and configure the switches as necessary.

9.3.8 Codec Sense Line

In the complex systems of today, there is an increasing amount of ICs on any given board. The issue this creates is that a codec can be far away from the audio jack and there is a potential difference between the grounding of the codec and the grounding of the headset.

By incorporating a ground sense line into the TS3A227E the codec can compensate for this offset and create a higher quality audio experience.

9.3.9 FM Support

FM can be picked up using the headset ground line and passed through the ground FETs of the TS3A227E. By having a bandwidth of 200 MHz the full FM band can be passed through these FETs to a FM matching network and the FM receiver.

9.4 Device Functional Modes

9.4.1 Sleep Mode

The device will realize a sleep mode of 1 μ A if the following are true:

- No accessory is inserted
- Manual Switch Control = '0'

The TS3A227E will respond to I2C communication and insertion events while in sleep mode. The user can set the de-bounce settings and device configuration as desired while in the sleep mode. If the user sets the Manual Switch Control bit to '1' the device will turn on all blocks and come out of sleep mode.

If there is no accessory inserted and the users exits manual switch control, the switches will revert to the no-insertion state and all unnecessary blocks of the TS3A227E will turn off and enter the sleep mode.

Device Functional Modes (接下页)

9.4.2 Manual Switch Control

The TS3A227E supports manual switch control that can be utilized by setting Bit6 of the Device Settings 1 register to '1'.

Key operational characteristics of manual switch control are below.

1. Enabling the manual switch control does not disable automatic insertion and accessory type detection.
2. Manual Switch Control is blocked during accessory type detection which includes an automatic detection sequence or a manual SW triggered detection sequence. Any changes to the switch control registers, or setting the device to manual switch control will not update the switches until after the accessory type detection has completed.
3. Manual Switch Control is also blocked during de-bounce periods.
4. Excluding items 2 and 3 above, immediately after the system enables manual switch control the switch states will change to reflect the switch control registers. It is advised to set the desired state of the switches before enabling manual switch control.
5. Turning off the depletion FETs of the device will result in increased power consumption as defined in the electrical characteristics table.
6. Immediately upon setting Manual Switch Control = '0' the device will automatically configure the switches to the latest detection state. If an accessory is inserted but the TS3A227E has not run detection due to Auto_Det_EN = '0', the switch status will revert to the no insertion state.
7. The device cannot be in sleep mode and utilize manual switch control at the same time.

9.4.3 Manual Switch Control Use Cases

The table below captures what occurs after a 3-pole insertion with the Manual Switch Control, Auto DET Enable, and DET Trigger bits set to the following before an insertion.

MANUAL SWITCH CONTROL	AUTO DET EN	DET TRIGGER (SW)	DOES TYPE DETECTION RUN	SWITCH STATUS AFTER INSERTION	DET TRIGGER (SW) AFTER INSERTION
0	0	0	no	No-insertion	0
0	0	1	yes	3-pole config	0
0	1	0	yes	3-pole config	0
0	1	1	yes	3-pole config	0
1	0	0	no	Switch control registers	0
1	0	1	yes	Switch control registers	0
1	1	0	yes	Switch control registers	0
1	1	1	yes	Switch control registers	0

The table below captures the switch and relevant register outputs for sequence 1.

EVENT NO.	EVENT DESCRIPTION	SWITCH STATUS	3-POLE BIT	4-POLE STANDARD BIT	4-POLE OMTP BIT
1	Device powers up	No-insertion	0	0	0
2	User sets Auto DET Enable = '0'	No-insertion	0	0	0
3	3-pole accessory is inserted	No-insertion	0	0	0
4	System sets Manual Switch Control = '1'	System controlled	0	0	0
5	System sets switch control registers = 0xFF	System controlled	0	0	0
6	System sets Manual Switch Control = '0'	No-insertion	0	0	0

TS3A227E

ZHCSD70B –NOVEMBER 2014–REVISED FEBRUARY 2015

www.ti.com.cn

In sequence 1 at event 3 the switch status does not change because the system set the Auto DET Enable = '0'. When the accessory is inserted we will not run detection and not change the switches because of this.

At event 6 the system turns off manual switch control, the switch state reverts back to the No-insertion state because the TS3A227E has not ran detection.

The table below captures the switch and relevant register outputs for sequence 2.

EVENT NO.	EVENT DESCRIPTION	SWITCH STATUS AFTER EVENT	3-POLE BIT	4-POLE STANDARD BIT	4-POLE OMTP BIT
1	Device powers up	No-insertion	0	0	0
2	User sets Auto DET Enable = '0'	No-insertion	0	0	0
3	3-pole accessory is inserted	No-insertion	0	0	0
4	System sets Manual Switch Control = '1'	System controlled	0	0	0
5	System sets switch control registers = 0xFF	System controlled	0	0	0
6	System sets DET Trigger = '1'	System controlled	1	0	0
7	System sets Manual Switch Control = '0'	3-pole configuration	1	0	0

In sequence 2 at event 3 the switch status does not change because the system set the Auto DET Enable = '0'. When the accessory is inserted we will not run detection and not change the switches because of this.

At event 6 the system turns triggers a manual type detection and the TS3A227E detects a 3-pole accessory. The switch state will remain in the system controlled state.

At event 7 the system exits manual switch control. The switch status will then change back to the last detection state. Because detection was ran at event 6 and a 3-pole was detected, the switch state will reflect that of the 3-pole switch configuration.

9.4.4 FM Support Mode

FM support mode needs to be entered via I2C through the Device Settings register. This will turn off the depletion switches when an accessory is inserted, eliminating the extra ground path. The ground line of the headset/headphone is used for FM transmission. This signal must pass through the TS3A227E ground FETs as shown in [图 17](#) where the red line indicates the transmission path.



图 17. FM Support Transmission Path

注

FM support should be enabled before an accessory is inserted. Toggling the FM support bit after a headset is inserted can cause a pop noise to be heard by the end user.

9.5 Register Maps

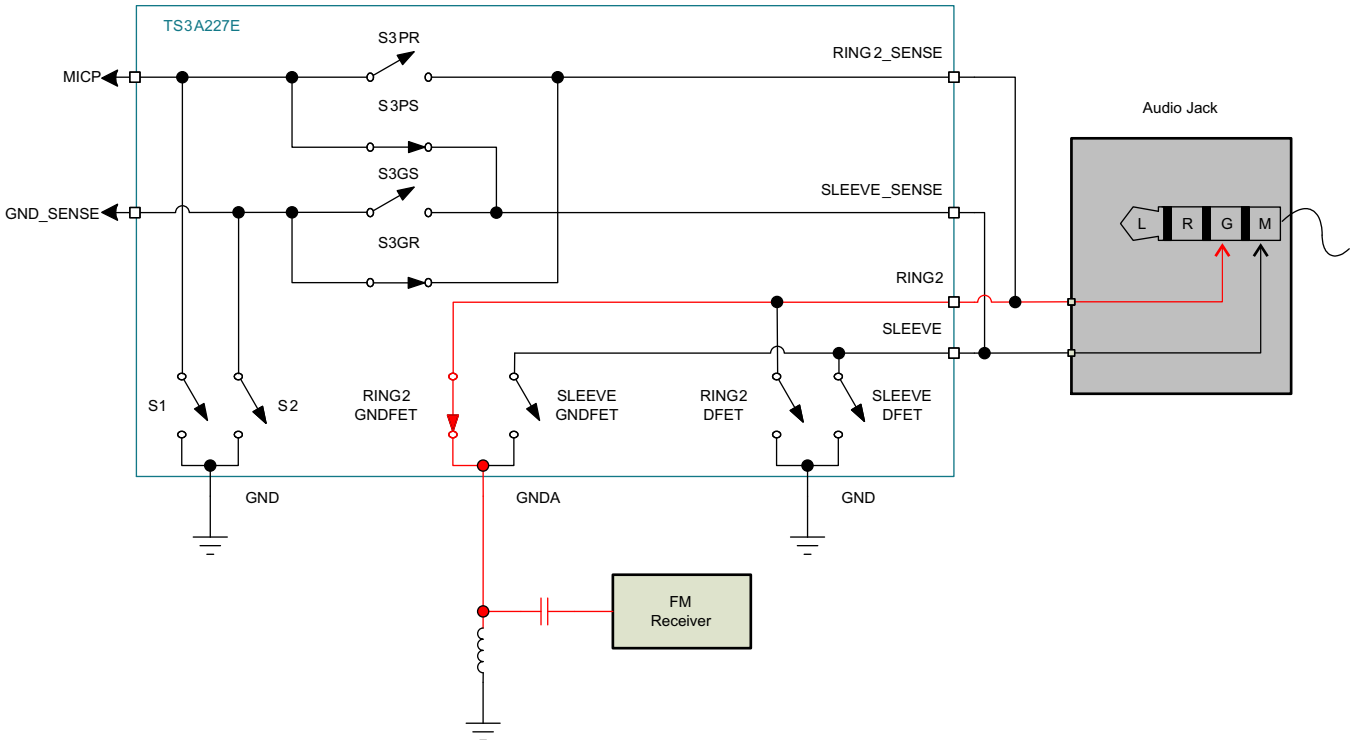
The I²C address of the TS3A227E is b'0111011X or 77h read and 76h write.

Addr (xxh)	Name	Type	Reset	Bit7	Bit6	Bit5	Bit4	Bit3	Bit2	Bit1	Bit0	
00h	Device ID	R	11h	0	0	0	1	0	0	0	1	
01h	Interrupt	R	00h	Reserved					ADC Conversion	DC	Ins/Rem Event	
02h	Key Press Interrupts	R	00h	Key 4 Release	Key 4 Press	Key 3 Release	Key 3 Press	Key 2 Release	Key 2 Press	Key 1 Release	Key 1 Press	
03h	Interrupt Disable	R/W	08h	Reserved				$\overline{\text{INT}}$ Disable	ADC Conversion INT Disable	DC $\overline{\text{INT}}$ Disable	Ins/Rem Event INT Disable	
04h	Device Settings	R/W	23h	Reset	Manual Switch Control	Auto DET Enable	DET Trigger	FM Support	Insertion De-bounce Time			
05h	Device Setting 1	R/W	00h	Reserved					Key Press Enable	Raw Data En	ADC Trigger	
06h	Device Setting 2	R/W	0Eh	Reserved		MICBIAS Setting			Key Release De-bounce	Key Press De-bounce		
07h	Switch Control 1	R/W	00h	Reserved		SLEEVE GDNFET	RING2 GDNFET	SLEEVE DFET	RING2 DFET	Switch 2	Switch 1	
08h	Switch Control 2	R/W	00h	Reserved				S3PS	S3PR	S3GS	S3GR	
09h	Switch Status 1	R	0Ch	Reserved		SLEEVE GDNFET	RING2 GDNFET	SLEEVE DFET	RING2 DFET	Switch 2	Switch 1	
0Ah	Switch Status 2	R	00h	Reserved				S3PS	S3PR	S3GS	S3GR	
0Bh	Accessory Status	R	00h	Reserved				Insertion Status	4-Pole Standard	4-pole OMTP	3-pole	
0Ch	ADC Output	R	00h	ADC								
0Dh	Threshold 1	R/W	20h	KP Threshold 1								
0Eh	Threshold 2	R/W	40h	KP Threshold 2								
0Fh	Threshold 3	R/W	68h	KP Threshold 3								

Interrupt and Key Press Interrupt register notes:

- The device will continue to automatically run type detection and key press detection even if the host has not serviced the interrupts.
- Consecutive reads of an interrupt register at 400 kHz will not allow time for the internal registers to clear and will appear. The internal digital core requires 200 μ s to clear the register after it has been read.

9.6 Register Field Descriptions

9.6.1 Device ID Register Field Descriptions (Address 00h)

图 18. Device ID Register Field Descriptions (Address 00h)

Bit	Field	Type	Reset	Description
7-0	Device ID	R	11h	Unique Revision number

9.6.2 Interrupt Register Field Descriptions (Address 01h)

表 2. Interrupt Register Field Descriptions (Address 01h)

Bit	Field	Type	Reset	Description
7-3	Reserved	R	0h	
2	ADC Conversion	R	0h	ADC Conversion complete Interrupt. Flagged after a manual ADC conversion is complete. Interrupt bit is cleared after being read through I2C or after a removal event. 0h = Default state 1h = ADC Conversion Complete
1	DC	R	0h	Detection Complete interrupt. Flagged after detection is completed for an insertion sequence. This bit is also flagged after completion of a manually triggered detection. Interrupt bit is cleared after being read through I2C or after a removal event. 0h = Default state 1h = Detection Completed
0	Ins/Rem Event	R	0h	Insertion or removal interrupt indicator. This bit is set if there is an insertion or removal event. The Insertion status bit of the Accessory Status register (0Bh) must be checked if this bit is set. Interrupt bit is cleared after being read through I2C 0h = Default state 1h = Accessory has been inserted or removed

9.6.3 Key Press Interrupt Register Field Descriptions (Address 02h)

表 3. Key Press Interrupt Register Field Descriptions (Address 02h)

Bit	Field	Type	Reset	Description
7	Key 4 Release	R	0h	This interrupt bit is set after the user has released key 4 on the accessory for a duration longer than the Key Release De-bounce timer. This bit will auto-clear on the following conditions: <ul style="list-style-type: none"> Host reads the register through I²C The KP Enable bit is set to '0' <ul style="list-style-type: none"> The KP Enable bit is set to '0' automatically after a removal The Key 4 press bit is set to '1' 0h = Default State 1h = Key 4 was released
6	Key 4 Press	R	0h	This interrupt bit is set after the user has pressed key 4 on the accessory for a duration longer than the Key Press De-bounce timer. This bit will auto-clear on the following conditions: <ul style="list-style-type: none"> Host reads the register through I²C The KP Enable bit is set to '0' <ul style="list-style-type: none"> The KP Enable bit is set to '0' automatically after a removal 0h = Default State 1h = Key 4 was released
5	Key 3 Release	R	0h	This interrupt bit is set after the user has pressed Key 3 on the accessory for a duration longer than the Key Release De-bounce timer. This bit will auto-clear on the following conditions: <ul style="list-style-type: none"> Host reads the register through I²C The KP Enable bit is set to '0' <ul style="list-style-type: none"> The KP Enable bit is set to '0' automatically after a removal The Key 3 Press bit is set to '1' 0h = Default State 1h = Key 3 was released

表 3. Key Press Interrupt Register Field Descriptions (Address 02h) (接下页)

Bit	Field	Type	Reset	Description
4	Key 3 Press	R	0h	<p>This interrupt bit is set after the user has pressed Key 3 on the accessory for a duration longer than the Key Press De-bounce timer.</p> <p>This bit will auto-clear on the following conditions:</p> <ul style="list-style-type: none"> • Host reads the register through I²C • The KP Enable bit is set to '0' <ul style="list-style-type: none"> — The KP Enable bit is set to '0' automatically after a removal <p>0h = Default State 1h = Key 3 was released</p>
3	Key 2 Release	R	0h	<p>This interrupt bit is set after the user has pressed Key 2 on the accessory for a duration longer than the Key Release De-bounce timer.</p> <p>This bit will auto-clear on the following conditions:</p> <ul style="list-style-type: none"> • Host reads the register through I²C • The KP Enable bit is set to '0' <ul style="list-style-type: none"> — The KP Enable bit is set to '0' automatically after a removal • The Key 2 Press bit is set to '1' <p>0h = Default State 1h = Key 2 was released</p>
2	Key 2 Press	R	0h	<p>This interrupt bit is set after the user has pressed Key 2 on the accessory for a duration longer than the Key Press De-bounce timer.</p> <p>This bit will auto-clear on the following conditions:</p> <ul style="list-style-type: none"> • Host reads the register through I²C • The KP Enable bit is set to '0' <ul style="list-style-type: none"> — The KP Enable bit is set to '0' automatically after a removal <p>0h = Default State 1h = Key 2 was released</p>
1	Key 1 Release	R	0h	<p>This interrupt bit is set after the user has pressed Key 1 on the accessory for a duration longer than the Key Release De-bounce timer. This bit is used for raw data release events.</p> <p>This bit will auto-clear on the following conditions:</p> <ul style="list-style-type: none"> • Host reads the register through I²C • The KP Enable bit is set to '0' <ul style="list-style-type: none"> — The KP Enable bit is set to '0' automatically after a removal • The Key 1 Press bit is set to '1' <p>0h = Default State 1h = Key 1 was released</p>
0	Key 1 Press	R	0h	<p>This interrupt bit is set after the user has pressed Key 1 on the accessory for a duration longer than the Key Press De-bounce timer. This bit is used for raw data press events.</p> <p>This bit will auto-clear on the following conditions:</p> <ul style="list-style-type: none"> • Host reads the register through I²C • The KP Enable bit is set to '0' <ul style="list-style-type: none"> — The KP Enable bit is set to '0' automatically after a removal <p>0h = Default State 1h = Key 1 was released</p>

9.6.4 Interrupt Disable Register Field Descriptions (Address 03h)

表 4. Interrupt Disable Register Field Descriptions (Address 03h)

Bit	Field	Type	Reset	Description
7-3	Reserved	R	0h	
+3	$\overline{\text{INT}}$ Disable	R/W	1h	Enables or disables all interrupts. Disabling the interrupts will cause the $\overline{\text{INT}}$ to not assert but the bits will still populate. 0h = interrupts are enabled 1h = interrupts are disabled
2	ADC Conversion $\overline{\text{INT}}$ Disable	R/W	0h	Enables or disables the ADC conversion interrupt. Disabling the interrupt will cause $\overline{\text{INT}}$ to not assert but the interrupt bit will still be set . In the use case that this bit is == '1' and a key is pressed, the Key Press interrupt will still assert the $\overline{\text{INT}}$ pin. If the host issues a software ADC trigger after the key has been pressed, the interrupt will not assert as that ADC conversion is the only interrupt present. 0h = ADC Conversion interrupt is enabled 1h = ADC Conversion interrupt is disabled
1	DC $\overline{\text{INT}}$ Disable	R/W	0h	Enables or disables the DC interrupt. Disabling the interrupt will cause $\overline{\text{INT}}$ to not assert but the interrupt bit will still be set. 0h = DC interrupt is enabled 1h = DC interrupt is disabled
0	Ins/Rem Event $\overline{\text{INT}}$ Disable	R/W	0h	Enables or disables the Ins/Rem Event interrupt. Disabling the interrupt will cause $\overline{\text{INT}}$ to not assert but the interrupt bit will still be set. 0h = Ins/Rem Event interrupt is enabled 1h = Ins/Rem Event interrupt is disabled

9.6.5 Device Settings Field Descriptions (Address 04h)

表 5. Device Settings Field Descriptions (Address 04h)

Bit	Field	Type	Reset	Description
7	Reset	R/W	0h	Initiates software reset of the TS3A227E. This will interrupt any on-going operation internal to the device. 0h = Default state 1h = Initiates a reset
6	Manual Switch Control	R/W	0h	Enables Manual control of the TS3A227E switches. After enabling manual switch control the switch status will immediately reflect the values in the switch control registers provided accessory type. 0h = Manual switch control disabled 1h = Manual switch control enabled
5	Auto DET Enable	R/W	1h	Controls whether detection is automatically ran after an insertion. 0h = Auto accessory detection is disabled 1h = Auto accessory detection is enabled
4	DET Trigger	R/W	0h	Manually triggers detection. This bit is auto cleared after detection is completed. A DET Trigger request will be ignored in the following cases: <ul style="list-style-type: none"> • A detection event is currently being service. • The interrupt register is not cleared (Register 02h must be = 00h) • There is no accessory inserted (/DET_TRIGGER is high) 0h = Default value 1h = Manually trigger detection
3	FM Support	R/W	0h	Turns on FM support. This will turn off the depletion FETs if any accessory is inserted allowing FM transmission through the ground FETs at the cost of increased current consumption. 0h = FM not supported and depletion FETs are on after an insertion 1h = FM supported and depletion FETs are off after an insertion

表 5. Device Settings Field Descriptions (Address 04h) (接下页)

Bit	Field	Type	Reset	Description
2.0	Insertion De-bounce Time	R/W	3h	<p>Controls the insertion de-bounce timer. Values below are typical values that have $\pm 30\%$ variation. Values in addition have a ± 1 ms variation though this will only really affect the 2 ms timer.</p> <p>0h = 2 ms 1h = 30 ms 2h = 60 ms 3h = 90 ms 4h = 120 ms 5h = 150 ms 6h = 1 s 7h = 2 s</p>

9.6.6 Key Press Settings 1 Field Descriptions (Address 05h)
表 6. Device Settings 1 Field Descriptions (Address 05h)

Bit	Field	Type	Reset	Description
7-3	Reserved	R	0h	
2	Key Press Enable	R/W	0h	<p>Enables the Key Press detection of the TSA227E. This bit auto clears after a removal event.</p> <p>If the Key Press Enable bit is set '1' and the Manual Switch Control bit is set to '1', the S3 matrix must be in one of the two correct position as described in the Key Press Detection section for the TS3A227E to run key press detection.</p> <p>0h = Default state 1h = Enables Key Press detection</p>
1	Raw Data En	R/W	0h	<p>Enables the Raw data mode for Key Press Detection. This bit auto clears if the Key Press Enable bit is set to '0'.</p> <p>Enabling raw data mode will not clear the KP interrupt register. After enabling Raw Data any key press and release event is recorded using the Key 1 Press and Key 2 Press Release event. The ADC conversion will be recorded in the ADC output register.</p> <p>0h = Raw Data is not enabled 1h = Raw Data is enabled</p>
0	ADC Trigger	R/W	0h	<p>Causes a manual ADC trigger if the Key Press Enable and Raw Data EN bits are both set to '1'. After the ADC conversion is complete the ADC Conversion interrupt will be set and the ADC Output register will be populated.</p> <p>This bit auto clears after the ADC Conversion is complete. A new ADC Conversion can be initiated even if the ADC Conversion interrupt has not been serviced.</p> <p>0h = Default State 1h = Triggers ADC conversion</p>

9.6.7 Key Press Settings 2 Field Descriptions (Address 06h)
表 7. Device Settings 2 Field Descriptions (Address 06h)

Bit	Field	Type	Reset	Description
7-6	Reserved	R	0h	
5-3	MICBIAS Setting	R/W	1h	This controls the key press threshold. Set this setting closest to the intended MICBIAS voltage 0h = 2.1 V 1h = 2.2 V (Default) 2h = 2.3 V 3h = 2.4 V 4h = 2.5 V 5h = 2.6 V 6h = 2.7 V 7h = 2.8 V
2	Key Release De-bounce	R/W	1h	Controls the Key-Release de-bounce timer. Values below are typical values that have $\pm 30\%$ variation. Values in addition have a ± 1 ms variation though this will only really affect the 2 ms timer. 0h = 2 ms 1h = 20 ms (Default)
1-0	Key Press De-bounce	R/W	2h	Controls the key press de-bounce timer. Values below are typical values that have $\pm 30\%$ variation. Values in addition have a ± 1 ms variation though this will only really affect the 2 ms timer. 0h = 2 ms 1h = 40 ms 2h = 80 ms (Default) 3h = 120 ms

9.6.8 Switch Control 1 Field Descriptions (Address 07h)
表 8. Switch Control 1 Field Descriptions (Address 07h)

Bit	Field	Type	Reset	Description
7-6	Reserved	R	0h	
5	SLEEVE GDNFET	R/W	0h	Configures the state of the SLEEVE GDNFET if manual switch control is enabled. If manual switch control is not enabled this bit is ignored. 0h = SLEEVE GDNFET switch off 1h = SLEEVE GDNFET switch on
4	RING2 DFET	R/W	0h	Configures the state of the RING2 GDNFET if manual switch control is enabled. If manual switch control is not enabled this bit is ignored. 0h = RING2 GDNFET switch off 1h = RING2 GDNFET switch on
3	SLEEVE DFET	R/W	0h	Configures the state of the SLEEVE DFET if manual switch control is enabled. If manual switch control is not enabled this bit is ignored. 0h = SLEEVE DFET switch off 1h = SLEEVE DFET switch on
2	RING2 DFET	R/W	0h	Configures the state of the RING2 DFET if manual switch control is enabled. If manual switch control is not enabled this bit is ignored. 0h = RING2 DFET switch off 1h = RING2 DFET switch on
1	Switch 2	R/W	0h	Configures the state of the Switch 2 if manual switch control is enabled. If manual switch control is not enabled this bit is ignored. 0h = Switch 2 off 1h = Switch 2 on
0	Switch 1	R/W	0h	Configures the state of the Switch 1 if manual switch control is enabled. If manual switch control is not enabled this bit is ignored. 0h = Switch 1 off 1h = Switch 1 on

9.6.9 Switch Control 2 Field Descriptions (Address 08h)
表 9. Switch Control 2 Field Descriptions (Address 08h)

Bit	Field	Type	Reset	Description
7-4	Reserved	R	0h	
3	S3PS	R/W	0h	Configures the state of the S3PS if manual switch control is enabled. If manual switch control is not enabled this bit is ignored. 0h = S3PS switch off 1h = S3PS switch on
2	S3PR	R/W	0h	Configures the state of the S3PR if manual switch control is enabled. If manual switch control is not enabled this bit is ignored. 0h = S3PR switch off 1h = S3PR switch on
1	S3GS	R/W	0h	Configures the state of the S3GS if manual switch control is enabled. If manual switch control is not enabled this bit is ignored. 0h = S3GS off 1h = S3GS on
0	S3GR	R/W	0h	Configures the state of the S3GR if manual switch control is enabled. If manual switch control is not enabled this bit is ignored. 0h = S3GR off 1h = S3GR on

9.6.10 Switch Status 1 Field Descriptions (Address 09h)
表 10. Switch Status 1 Field Descriptions (Address 09h)

Bit	Field	Type	Reset	Description
7-6	Reserved	R	0h	
5	SLEEVE GDNFET	R	0h	Indicates the status of SLEEVE GDNFET 0h = SLEEVE GDNFET switch is off 1h = SLEEVE GDNFET switch is on
4	RING2 GDNFET	R	0h	Indicates the status of RING2 GDNFET 0h = RING2 GDNFET switch is off 1h = RING2 GDNFET switch is on
3	SLEEVE DFET	R	1h	Indicates the status of SLEEVE DFET 0h = SLEEVE DFET switch is off 1h = SLEEVE DFET switch is on
2	RING2 DFET	R	1h	Indicates the status of RING2 DFET 0h = RING2 DFET switch is off 1h = RING2 DFET switch is on
1	Switch 2	R	0h	Indicates the status of Switch 2 0h = Switch 2 is off 1h = Switch 2 is on
0	Switch 1	R	0h	Indicates the status of Switch 1 0h = Switch 1 is off 1h = Switch 1 is on

9.6.11 Switch Status 2 Field Descriptions (Address 0Ah)
表 11. Switch Status 2 Field Descriptions (Address 0Ah)

Bit	Field	Type	Reset	Description
7-4	Reserved	R	0h	
3	S3PS	R	0h	Indicates the status of S3PS 0h = S3PS switch is off 1h = S3PS switch is on
2	S3PR	R	0h	Indicates the status of S3PR 0h = S3PR switch is off 1h = S3PR switch is on
1	S3GS	R	0h	Indicates the status of S3GS 0h = S3GS is off 1h = S3GS is on
0	S3GR	R	0h	Indicates the status of S3GR 0h = S3GR is off 1h = S3GR is on

9.6.12 Detection Results Field Descriptions (Address 0Bh)
表 12. Detection Results Field Descriptions (Address 0Bh)

Bit	Field	Type	Reset	Description
7-4	Reserved	R	0h	
3	Insertion Status	R	0h	Indicates if an accessory is inserted the jack or not. This bit is set to the corresponding state after an accessory is inserted or removed and should be read after the Ins/Rem Event interrupt has been set to '1'. 0h = An accessory is not in the jack 1h = An accessory is in the jack
2	4-pole Standard	R	0h	Indicates if a 4-pole Standard headset is detected. Bit is set after a completed detection sequence. 0h = Default state 1h = 4-pole standard headset detected
1	4-pole OMTP	R	0h	Indicates if a 4-pole OMTP headset is detected. Bit is set after a completed detection sequence. 0h = Default state 1h = 4-pole OMTP headset detected
0	3-pole	R	0h	Indicates if a 3-pole headphone is detected. Bit is set after a completed detection sequence. 0h = Default state 1h = 3-pole headphone detected

9.6.13 ADC Output Field Descriptions (Address 0Ch)
表 13. ADC Output Field Descriptions (Address 0Ch)

Bit	Field	Type	Reset	Description
7-1	ADC	R/W	00h	This field contains the output of the key press detection ADC as described in the key press detection register
0	Reserved	R	0h	

9.6.14 Threshold 1 Field Descriptions (Address 0Dh)
表 14. Threshold 1 Field Descriptions (Address 0Dh)

Bit	Field	Type	Reset	Description
7-01	KP Threshold 1	R/W	20h	This field sets the key 1 and key 2 boundary threshold. This value must always be lower than the Threshold 2 register for proper operation.
0	Reserved	R	0h	

9.6.15 Threshold 2 Field Descriptions (Address 0Eh)
表 15. Threshold 2 Field Descriptions (Address 0Eh)

Bit	Field	Type	Reset	Description
7-1	KP Threshold 2	R/W	40h	This field sets the key 2 and key 3 boundary threshold. This value must always be lower than the Threshold 3 register and higher than the threshold 2 register for proper operation.
0	Reserved	R	0h	

9.6.16 Threshold 3 Field Descriptions (Address 0Fh)
表 16. Threshold 3 Field Descriptions (Address 0Fh)

Bit	Field	Type	Reset	Description
7-1	KP Threshold 3	R/W	68h	This field sets the key 3 and key 4 boundary threshold. This value must always be higher than the Threshold 2 register for proper operation.
0	Reserved	R	0h	

10 Application and Implementation

10.1 Application Information

Figure 19 shows how a standard application schematic for the TS3A227E. The DSBGA package pin connections will be the same except for the lack of thermal pad. The following sections discuss how the TS3A227E works with different headsets and how the key press detection operates.

10.2 Typical Application



图 19. Typical Application Schematic

表 17. Component List

COMPONENT	VALUE	NOTES
R1	4.7 kΩ	Pullup resistor must be sized to not exceed max IOL specification for $\overline{\text{INT}}$ pin
R2	4.7 kΩ	Pullup resistor must be sized to not exceed max IOL specification for $\overline{\text{INT}}$ pin
R3	4.7 kΩ	Pullup resistor must be sized to not exceed max IOL specification for $\overline{\text{INT}}$ pin
R4	4.7 kΩ	Pullup resistor must be sized to not exceed max IOL specification for $\overline{\text{INT}}$ pin
R5	10 kΩ	Pulldown resistor for high to low transition on $\overline{\text{DET_TRIGGER}}$
R6	2.2 kΩ ±1%	MICBIAS pullup resistor must be ±1% for Key Press Detection to function properly
C1	10 μF	De-coupling capacitor for V _{DD}
C2	100 nF	De-coupling capacitor for V _{DD}
C3	1 μF	Value can vary depending on codec needs
C4	47 nF	Value can vary depending on FM matching network needs. If FM transmission is not being supported by the application this capacitor is not needed
L1	180 nF	Value can vary depending on FM matching network needs. If FM transmission is not being supported by the application this inductor is not needed and GNDA must be shorted to GND

10.2.1 Design Requirements

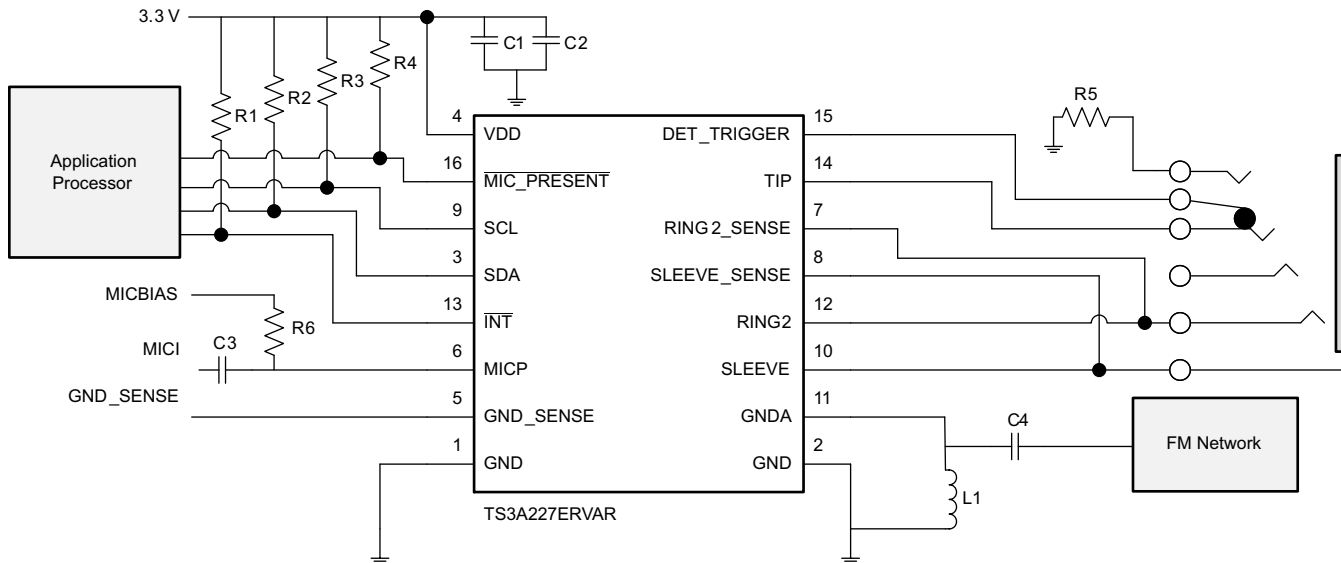
10.2.1.1 Standard I²C Interface Details

The bi-directional I²C bus consists of the serial clock (SCL) and serial data (SDA) lines. Both lines must be connected to a positive supply via a pull-up resistor when connected to the output stages of a device. Data transfer may be initiated only when the bus is not busy.

I²C communication with this device is initiated by the master sending a START condition, a high-to-low transition on the SDA line while the SCL line is high. After the start condition, the device address byte is send, MSB first, including the data direction bit (R/W). This device does not respond to the general call address. After receiving the valid address byte (0x77 read, 0x76 write), this device responds with an ACK, a low on the SDA line during the high of the ACK-related clock pulse.

The data byte follows the address ACK. The R/W bit is kept low for transfer from the master to the slave. The data byte is followed by an ACK sent from this device. Data are output only if complete bytes are received and acknowledged. The output data is valid at time (tpv) after the low-to-high transition of SCL, during the clock cycle for the ACK.

On the I²C bus, only one data bit is transferred during each clock pulse. The data on the SDA line must remain stable during the high pulse of the clock period, as changes in the data line at this time are interpreted as control commands (START or STOP).

A Stop condition, a low-to-high transition on the SDA line while the SCL line is high, is sent by the master. The number of data bytes transferred between the start and the stop conditions from the transmitter to receiver is not limited. Each byte of eight bits is followed by one ACK bit. The transmitter must release the SDA line before the receiver can send an ACK bit.

A slave receiver that is addressed must generate an ACK after the reception of each byte. The device that acknowledges has to pull down the SDA line during the ACK clock pulse so that the SDA line is stable low during the high pulse of the ACK-related clock period. Setup and fold times must be taken into account.



图 20. Acknowledgment on the I²C Bus

10.2.1.2 Write Operations

Data is transmitted to the TS3A227E by send the device salve address and setting the LSB to a logic 0. The command byte is sent after the address and determines which register receives the data that follows the command byte. The next byte is written to the specified register on the rising edge of the ACK clock pulse. See Figure 2 and Figure 3 for different modes of write operations.

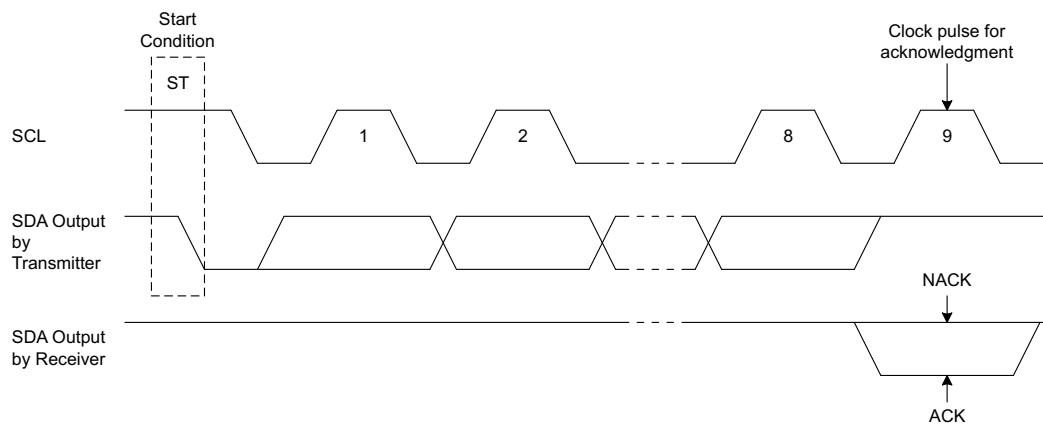

图 21. Repeated Data Write to a Single Register



图 22. Burst Data Write to Multiple Registers

10.2.1.3 Read Operations

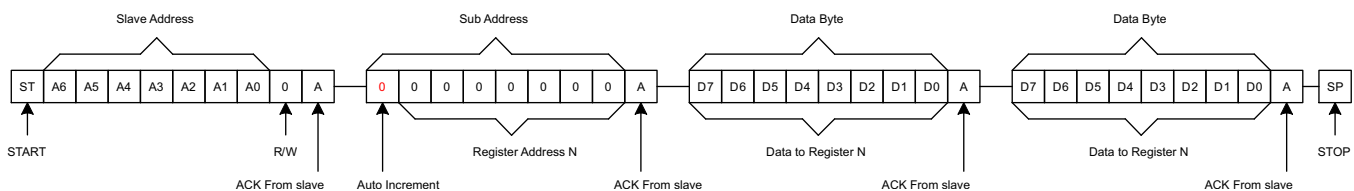
The bus master must send the TS3A227E slave address with the LSB set to logic 0. The command byte is sent after the address and determines which register is accessed. After a restart, the device slave address is sent again but this time the LSB is set to logic 1. Data from the register defined by the command byte then is sent back to the host by the TS3A227E. Data is clocked into the SDA output shift register on the rising edge of the ACK clock pulse. 图 23 and 图 24 show read operations that use a restart between the sub-address write and the read operation. A Stop and start condition between the sub-address write and the read operation is also acceptable.

Notes:

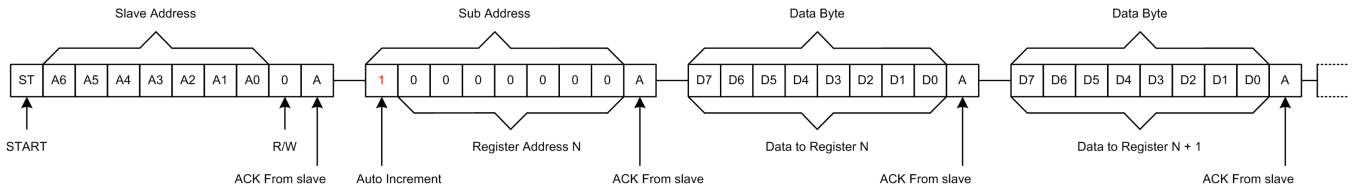
1. SDA is pulled low on ACK from the slave or master.
2. Register write always require sub-address write before writing the first data.
3. Repeated data writes to a single register continue indefinitely until an I²C Stop or Re-start.
4. Repeated data reads from a single register continue indefinitely until an I²C NACK is received from the master.
5. Burst data writes start at the specified register address, then advance to the next register address, even to the read-only registers and continue until the Stop or Re-start. For the read-only registers, data write appears to occur, although the register contents are not changed by the write operations.
6. Burst data reads start at the specified register address, then advance to the next register address and continues until an I²C NACK is received from the master.



图 23. Repeated Data Read From a Single Register



图 24. Burst Data Read From Multiple Registers

10.2.2 Detailed Design Procedure

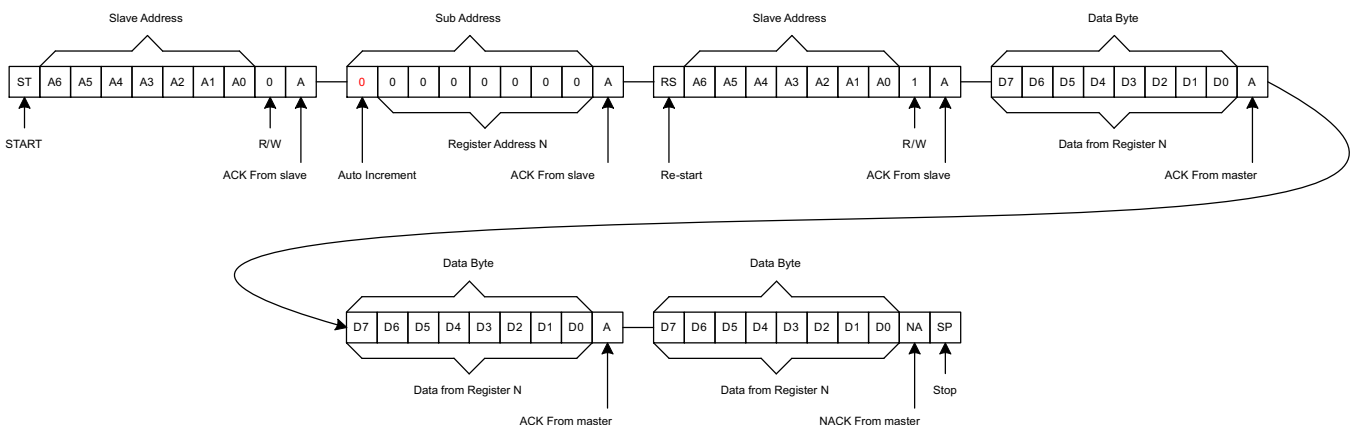
10.2.2.1 Accessory Insertion

The TS3A227E monitors the DET_TRIGGER pin to determine when an insertion event occurs. A high to low transition on the DET_TRIGGER pin will start the internal de-bounce timer (default 90 ms). This transition is shown in 图 19. Once the de-bounce timer has expired, it is determined that an accessory is inserted and the detection algorithm is performed to determine what the accessory is and where the ground line is located.

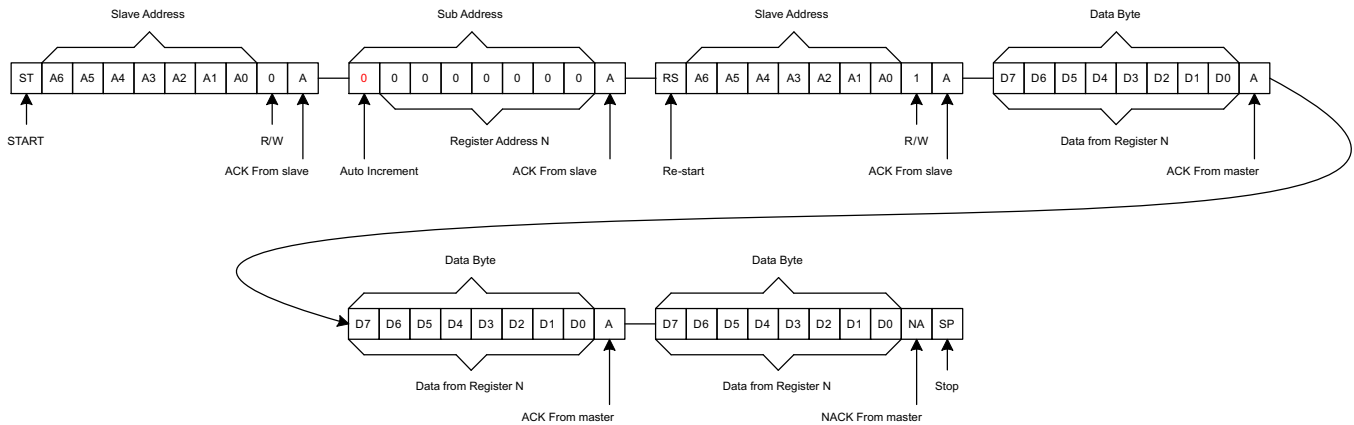

图 25. DET_TRIGGER Transition Diagram

Once a DET_TRIGGER transition has occurred, any I²C register changes will not be serviced until after the de-bounce and detection sequence have completed. If DET_TRIGGER transitions from Low to High before the de-bounce period has expired. The I²C register changes will be serviced before a new de-bounce timer is started from another High to Low transition on the DET_TRIGGER pin. The I²C communication has to complete before the next High to Low transition to take effect.

10.2.2.2 Audio Jack Selection

The audio jack the system uses plays a key role in how the system performs and the experience the end user has with the equipment. In real-world scenarios a user might plug in the headset to the audio jack very slowly. This creates a challenging case for the TS3A227E detection mechanism and detection error can occur if care is not taken when designing the components around the TS3A227E.

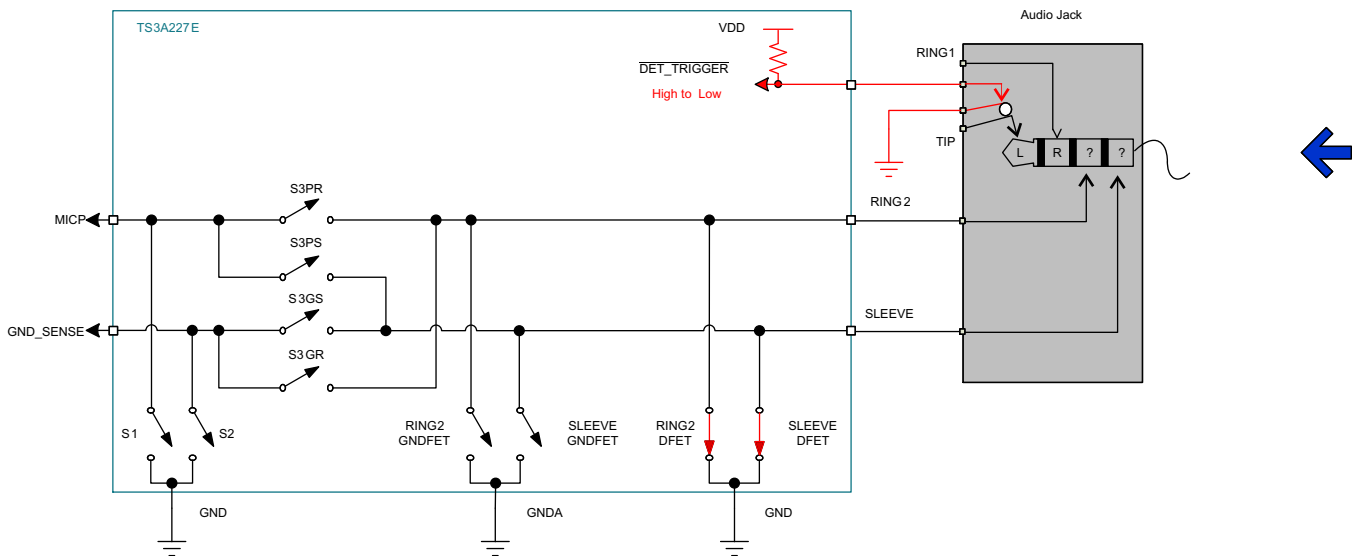
The main concern for slow plug-in is the detection process may have already started before the headset is fully inserted into the jack. If the detection is running with the headset out of position, a false impedance measurement may occur. For best performance a jack should be chosen that puts the detection mechanism on the TIP pin at the end of physical jack to ensure that it is fully inserted.

The TS3A227E EVM contains test points for all the jack pins and can be blue wired to prototype audio jacks for testing.

10.2.2.3 Switch Status

表 18 depicts the switch status for each device configuration. A switch diagram is provided in 图 26.

表 18. Switch Status

Device State	S1	S2	S3PS	S3PR	S3GS	S3GR	RING2 GDNFET	SLEEVE GDNFET	RING2 DFET	SLEEVE DFET
Default State (No insertion or VDD = 0 V)	High-Z	High-Z	High-Z	High-Z	High-Z	High-Z	High-Z	High-Z	On	On
Detection running	High-Z	On	High-Z	High-Z	High-Z	High-Z	High-Z	High-Z	High-Z	High-Z
3-pole	On	High-Z	High-Z	High-Z	On	On	On	On	On	On
3-pole with FM support	On	High-Z	High-Z	High-Z	High-Z	On	On	High-Z	High-Z	High-Z
4-pole OMTP	High-Z	High-Z	High-Z	On	On	High-Z	High-Z	On	High-Z	On
4-pole OMTP with FM support	High-Z	High-Z	High-Z	On	On	High-Z	High-Z	On	High-Z	High-Z
4-pole Standard	High-Z	High-Z	On	High-Z	High-Z	On	On	High-Z	On	High-Z
4-pole Standard with FM support	High-Z	High-Z	On	High-Z	High-Z	On	On	High-Z	High-Z	High-Z



图 26. Switch Diagram

TS3A227E

ZHCSD70B – NOVEMBER 2014 – REVISED FEBRUARY 2015

www.ti.com.cn

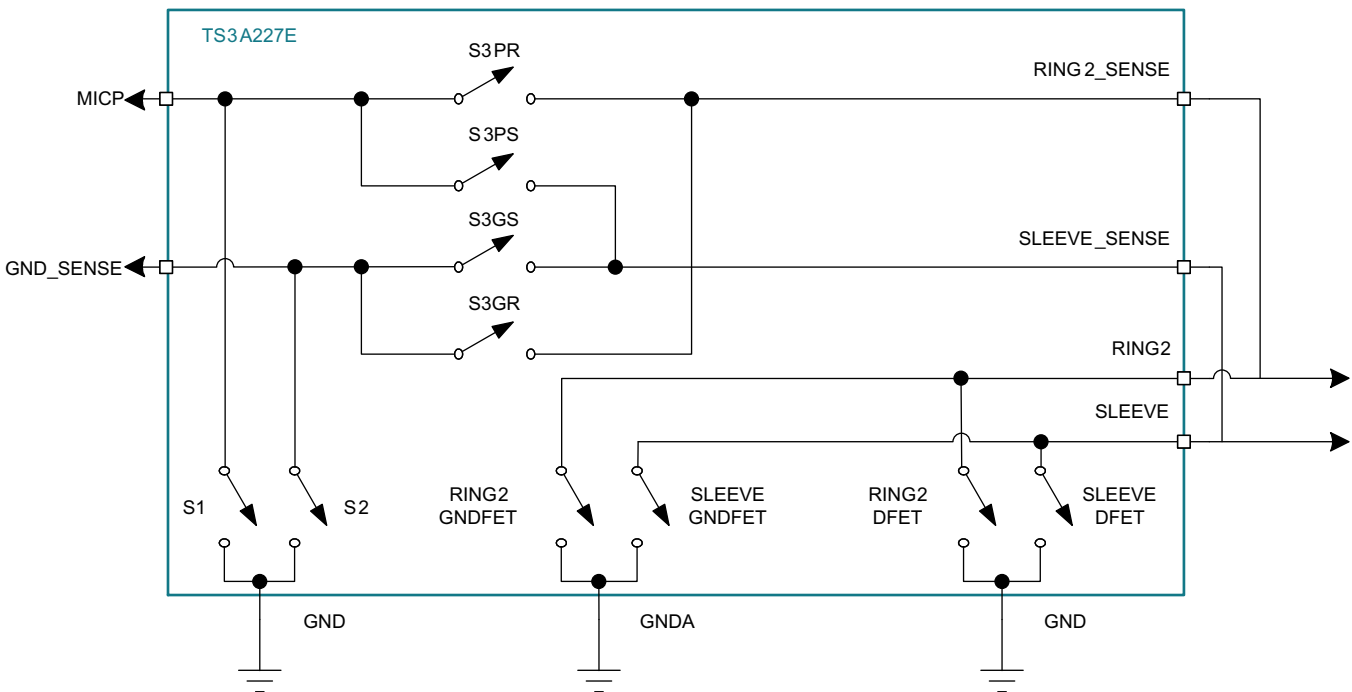
10.2.2.3.1 Switch Status Diagrams

Closed switches are red in 图 27 through 图 31. The diagrams reflect switch states when manual switch control is not enabled.



图 27. Default Switch State With No Accessory Inserted



图 28. Switch State During Detection

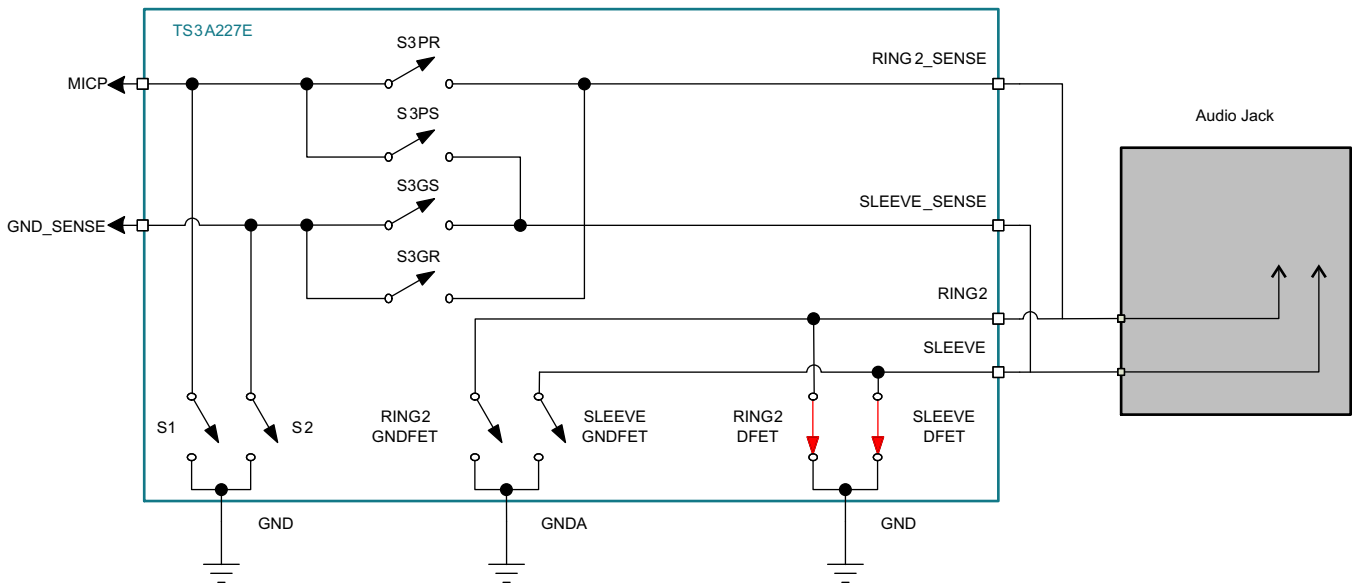

图 29. Switch State After Detecting a 3-Pole Headphone

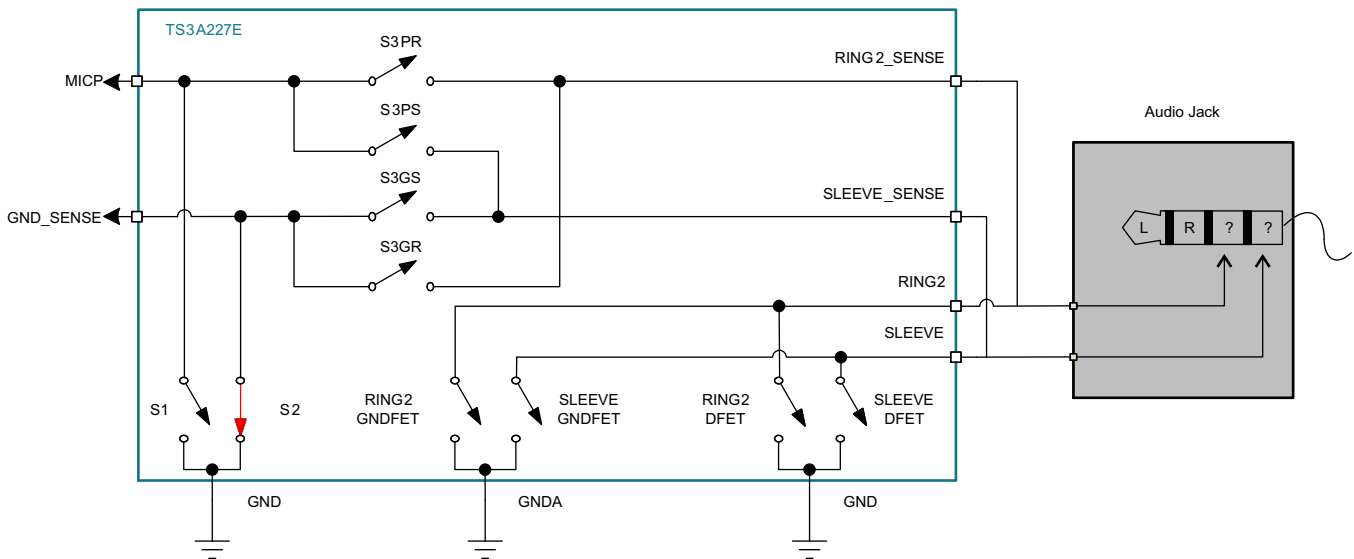

图 30. Switch State After Detection a 4-pole OMTP Headset

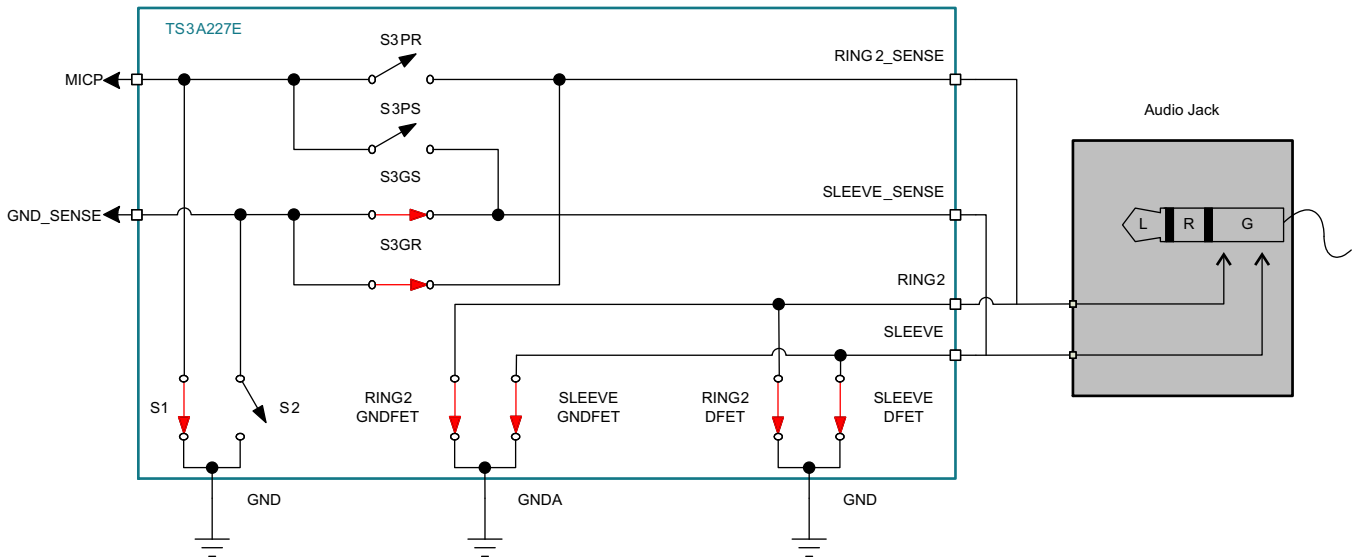

图 31. Switch State After Detecting a 4-Pole Standard Headset

10.2.2.4 Key Press Detection

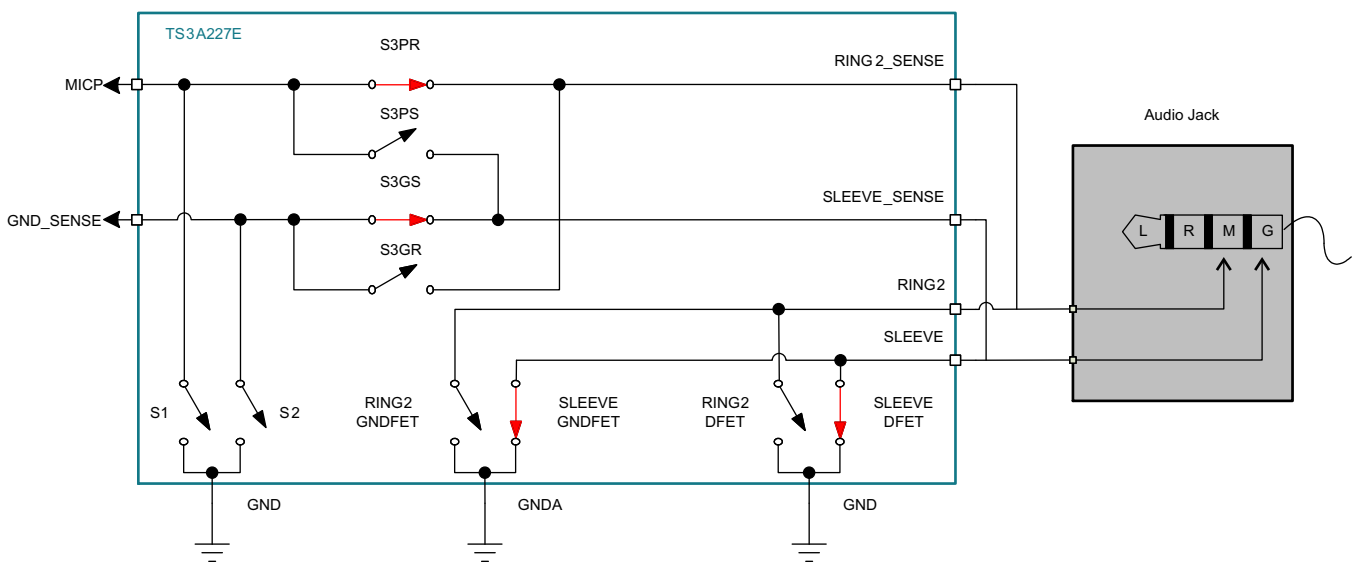
10.2.2.4.1 Key Press Thresholds

The TS3A227E features the ability to adjust the key press thresholds on the fly. The default key press bins are shown below with the default values of the threshold registers optimized to detect these keys. The values for the bins represent the equivalent resistance of the key being pressed with the microphone in parallel. Any equivalent resistance outside these bins is not guaranteed to be detected correctly.

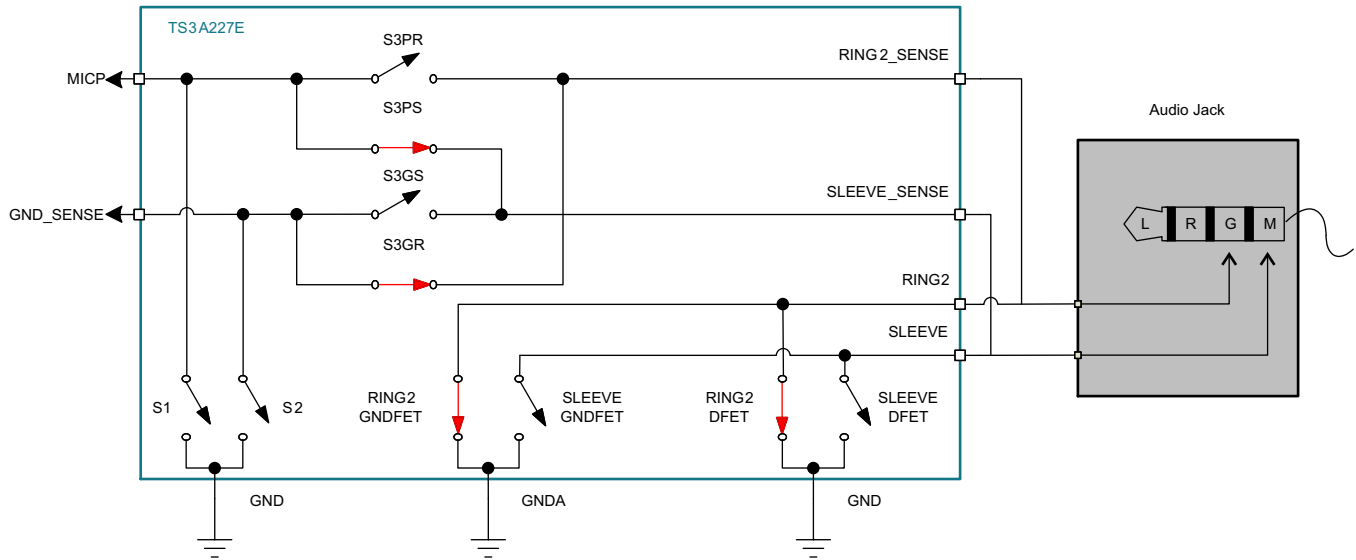
KEY	TYPICAL RESISTANCE	EQUIVALENT RESISTANCE RANGE
Key 1	50 Ω	0 Ω – 66 Ω
Key 2	135 Ω	126 Ω – 156 Ω
Key 3	240 Ω	228 Ω – 264 Ω
Key 4	470 Ω	360 Ω – 680 Ω

The Threshold 1 register (Address 0Dh) adjusts the detection boundary between Key 1 and Key2. The Threshold 2 register (Address 0Eh) adjusts the detection boundary between Key 2 and Key 3. The Threshold 3 register (Address 0Fh) adjusts the detection boundary between Key 3 and Key4.

The thresholds are 7 bit values that can be adjusted for the following formula.

$$\text{Target bin boundary} = \text{KP Threshold}[6:0] \times 6 \Omega \quad (1)$$

It is important for the proper operation of the KP detection algorithm that the thresholds be ordered correctly: KP Threshold 1 < KP Threshold 2 < KP Threshold 3. Placing them out of order will cause incorrect keys to be detected. For information on defining the key press gray zones see the Key Press Gray Zones section.

10.2.2.4.2 System Requirements

The Key Press detection algorithm has the following system requirements to be function properly:

- MICBIAS output voltage equivalent to key press settings 2 register value within 2.5%
- MICBIAS pullup resistance equal to 2.2 kΩ ±1%
- Audio jack contact resistance must be limited to < 100 mΩ. See further information below.

图 32 depicts the resistor network without the TS3A227E switches for simplicity.



图 32. Headset Microphone and Key Network

When the user presses a key it creates a voltage divider network between the MICBIAS output of the codec and the system ground. This will be a measurable voltage on the SLEEVE/RING2 pin that follows Equation 2. Note that this is simplified because it does not include the TS3A227E switches or the contact resistance of the jack itself.

$$V_{\text{SLEEVE/RING2}} = (V_{\text{MICBIAS}} + \Delta V_{\text{MICBIAS}}) \times \frac{R_{\text{EQ}}}{(2.2\text{k} + \Delta_{2.2\text{k}}) + R_{\text{EQ}}} \quad (2)$$

The R_{EQ} can be calculated with the following:

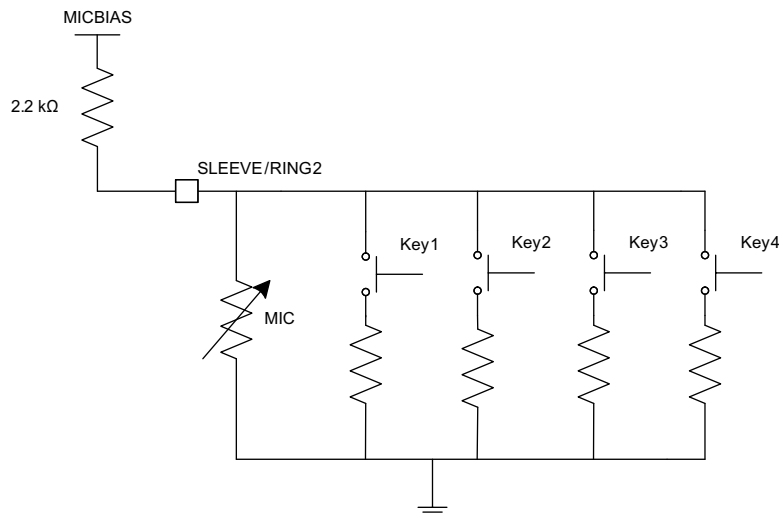
$$R_{\text{EQ}} = \frac{R_{\text{MIC}} \times R_{\text{KEY}}}{R_{\text{MIC}} + R_{\text{KEY}}} \quad (3)$$

As a result of the above calculations, an ADC attempting to detect the voltage on SLEEVE/RING2 to determine which key is pressed (whichever is the microphone pin) is reliant on the accuracy on the MICBIAS output and the 2.2 kΩ pull-up resistor. The key press bins are targeted assuming ideal values for these system conditions and then the gray zone between the bins takes into account the system variations. As a result the better the accuracy of the MICBIAS output and pull-up resistor the better the accuracy of the key press detection.

In addition to the above, the contact resistance of the audio jack itself can play a role in how accurate the key press detection is. A general rule is less contact resistance is better. In the figure below a more complete picture of the system and the voltage the TS3A227E will detect is shown.

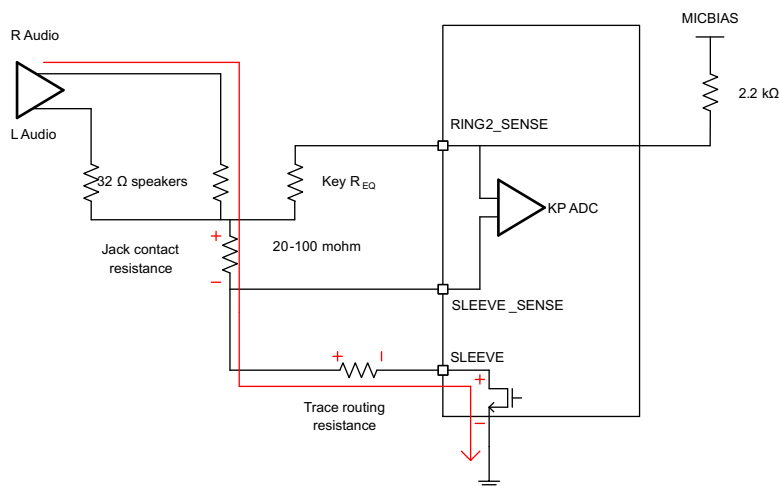

The red line denotes the current path for the output of the codec to follow when it enters the speakers and eventually sinks into the GNDFETs of the TS3A227E. This audio current adds a voltage offset at the audio jack contact resistance, the trace routing resistance, and the GNDFET itself. Because the TS3A227E has kelvin connections to the jack via the SLEEVE_SENSE RING2_SENSE pins the trace routing resistance and GNDFET induced voltage offsets can be compensated.

However, the jack contact resistance is not visible by the device and cannot be compensated for. To maintain the default bin targets the system must ensure that for a given audio jack contact resistance the max current being output by the codec/amplifier lies below the curve in [图 34](#). This ensures a max error introduced of 5 mV into the KP detection algorithm.

10.2.2.4.3 Key Press Grey Zones

When defining custom bins and thresholds it is important to also correctly define the “gray zone” between the bins to ensure that the system will always correctly identify the key that is being pressed. The gray zone region accounts for the absolute error in key press detection, encompasses the error of the internal ADC along with errors from system tolerances and variation. The equation below can be used to determine the gray zone required between each of the bins. Note that the size of the gray zone will vary depending on the actual value of the key press threshold.

$$\text{Gray Zone} = \pm [(\epsilon_{(\text{ADC,GAIN})} + \epsilon_{\text{MICBIAS}} + \epsilon_{\text{RBIAS}} + \epsilon_{(\text{CONT,GAIN})}) \times R_{(\text{KP Threshold})} + (\epsilon_{(\text{ADC,OFF})} + \epsilon_{(\text{CONT,OFF})} + K_{\text{BUFF}}) \times 6 \Omega] \quad (4)$$

TERM	DESCRIPTION	VALUE	UNIT
$\epsilon_{(\text{ADC,GAIN})}$	Internal ADC gain error	0.015%	
$\epsilon_{\text{MICBIAS}}$	Codec MICBIAS output voltage variation. Default bin values assume an output variation of 2.5%.	0.025% ⁽¹⁾	
ϵ_{RBIAS}	MICBIAS resistor variation. Default bin values assume a 1% tolerance of the 2.2 k Ω MICBIAS resistor.	0.01% ⁽¹⁾	
$\epsilon_{\text{CONT,GAIN}}$	Gain error introduced by contact resistance of the audio jack.	$\frac{R_{\text{Contact}} \times I_{\text{MAX}}}{V_{\text{MICBIAS}}}$	
$\epsilon_{\text{KP Threshold}}$	KP threshold target identified by system. E.g. the KP Threshold between bins 1 and 2 for the default key press bins is 96 Ω .	Defined by system ⁽¹⁾	Ω
$\epsilon_{\text{ADC,OFF}}$	Internal ADC offset and linearity error	1.5	LSB
$\epsilon_{\text{CONT,OFF}}$	Offset error introduced by contact resistance of the audio jack.	$\frac{R_{\text{Contact}} \times I_{\text{MAX}}}{\frac{V_{\text{MICBIAS}}}{128}}$	LSB
K_{BUFF}	Buffer constant added to total system gray zone to ensure bin values are detected correctly. It is recommended to use a minimum of 2 for this when defining key gray zones to ensure system level margins.	2	LSB
R_{Contact}	Max contact resistance of audio jack	Defined by system ⁽¹⁾	Ω
I_{MAX}	Maximum combined (Right and Left) audio output current into the jack.	Defined by system ⁽¹⁾	A
V_{MICBIAS}	MICBIAS output voltage of the codec	Defined by system ⁽¹⁾	V

(1) These values can vary depending on the system

Example Calculation

The default KP Threshold 1 value for the TS3A227E is 10h or 96 Ω . Using the Gray Zone equation the specified gray zone between keys 1 and 2 can be confirmed assuming the following:

- $V_{\text{MICBIAS}} = 2.2 \text{ V}$
- $I_{\text{MAX}} \times R_{\text{Contact}} = 5 \text{ mV}$
- $R_{(\text{KP Threshold})} = 96 \Omega$
- Default values for all other terms

$$\text{Gray Zone} = \pm \left[\left(0.015 + 0.025 + 0.01 + \frac{5\text{mV}}{2.2} \right) \times 96 \Omega + \left(1.5 + \frac{5\text{mV}}{2.2} + 2 \right) \times 6 \Omega \right] \quad (5)$$

This yields a gray zone of $\pm 27 \Omega$. The KP Threshold 1 gray zone can be used to identify the upper limit of key 1 and the lower limit of key 2:

$$\text{Bin 1 upper limit} = \text{KP Threshold 1} - \text{Gray Zone 1}$$

$$\text{Bin 2 lower limit} = \text{KP Threshold 1} + \text{Gray Zone 1}$$

This formula yields an upper limit of 69 Ω . Because each LSB is 6 Ω we round down to the even number of 66 Ω . For the beginning of key 2 we set the value at (96 Ω + 27 Ω) or 126 Ω (123 Ω rounded up to the nearest LSB). This method can be used to define the rest of the key bin thresholds.

10.2.2.4.4 Behavior

The TS3A227E can monitor the microphone line of a 4-pole headset to detect up to 4 key presses/releases and report the key press events back to the host. The key press detection must be activated manually by setting the KP Enable bit of the Device Settings 2 register. To ensure proper operation the MICBIAS voltage must be applied to MICP before enabling key press detection.



图 33. Proper Key Press Enable Sequence

The TS3A227E monitors the S3 switch matrix to determine the location of the microphone. If the Manual Switch Control bit is set to '1', the S3 matrix must be configured in one of the following 2 configurations for the key press detection to operate. Other configurations are not supported with key press detection.

S3PR	S3PS	S3GR	S3GS	MIC LOCATION
On	High-Z	High-Z	On	RING2
High-Z	On	On	High-Z	SLEEVE

If the voltage on the microphone line drops below the key press detection threshold for a duration longer than the key press de-bounce time, the key press is considered to be valid. At this point the detected key has the corresponding Key # Press interrupt bit set to '1' and the interrupt is asserted. The corresponding Key # Release interrupt is cleared at the same time the Key # Press interrupt is set.

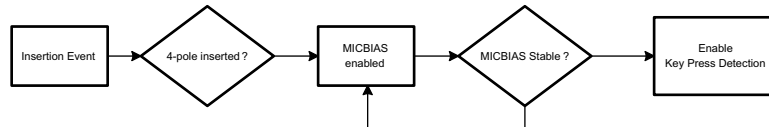
Once the key is released for a duration longer than the key release de-bounce time, a Key Release interrupt is generated to inform the host that the key has been released. The corresponding Key # released interrupt bit is set to '1' and the interrupt is asserted.

The Key Press interrupt register will clear the contents and return to the default status of 0h when Key Press detection is disabled via an I2C write or a removal event.

Notes about key press detection:

- The MICBIAS setting adjusts the detection threshold and must be set to the value that is closest to the MICBIAS output of the codec. If the MICBIAS voltage being used is between different MICBIAS settings of the TS3A227E then the closest value that is greater than the MICBIAS voltage should be used.
 - E.G. if the codec output is 2.2 V, the 2.3 V MICBIAS setting in the TS3A227E should be used.
- If any pending interrupt is not read by the host and a key is pressed, the TS3A227E will continue to run key press detection until the Key Press Enable bit is set to '0'

The host will interpret Key Press and Release interrupts using the following pseudo-code:

```

  If (Key # Press && Key # Release) {
    Key # was pressed one time and is not being held.
  }
  else if (Key # Release ) {
    Key # is being pressed, start the key press duration timer
  }
  else if (Key # Release) {
    Key # has been released, end the key press duration timer
  }

```

The key press duration timer the host starts after reading that a key is pressed can be used as follows:

```

  If (Key # Press Duration Timer > XXX ms) {
    The Key # is being held down, handle accordingly.

    E.g. if Key # is the volume up key, the system will increment the volume until the Key #
    Release interrupt is read from the TS3A227E
  }

```

10.2.2.4.5 Single Key Press Timing

The diagram below depicts a key press event where the MIC is on the SLEEVE pin. If the MIC is on RING2 the timing diagram will be same.

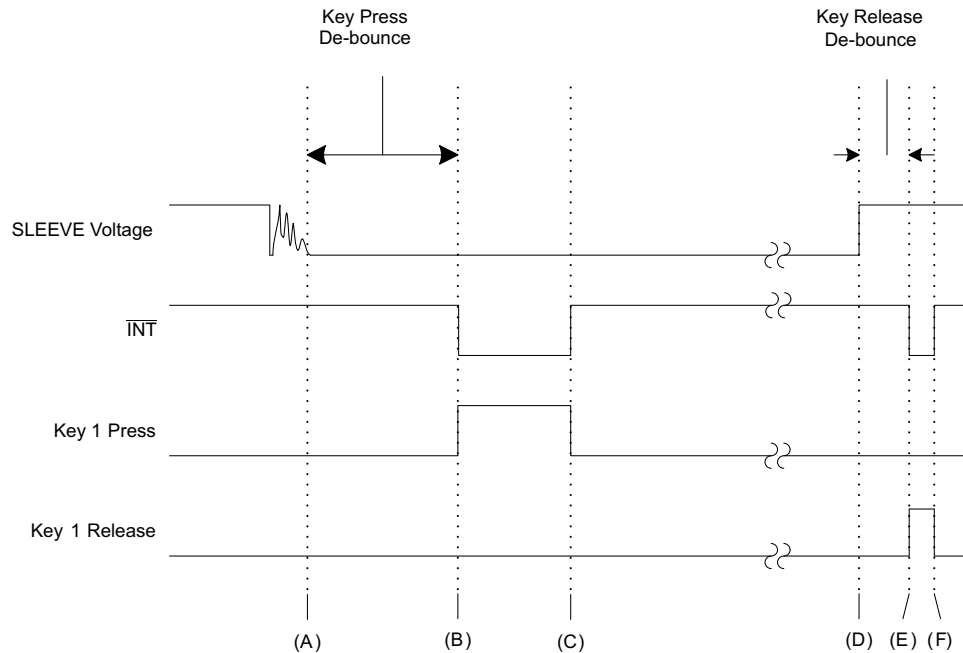

- A. At this point the SLEEVE voltage has stopped glitching and the Key Press De-bounce timer will no longer restart.
- B. Point B is the end of the key press de-bounce period. $\overline{\text{INT}}$ will be asserted with the Key Press bit set.
- C. The host read and clears the interrupt register, de-asserting the $\overline{\text{INT}}$ pin.
- D. Here the key is released and the key release de-bounce period begins.
- E. The key release de-bounce period ends and the $\overline{\text{INT}}$ pin is asserted again with the Key Release bit set.
- F. Here the host reads and clears the interrupt register, de-asserting the $\overline{\text{INT}}$ pin.

10.2.2.4.6 Multiple Key Press Timing

The diagram below depicts a multiple key press event in which the host does not immediately read the interrupt register. The MIC is on the SLEEVE pin in this diagram. If the MIC is on RING2 the timing diagram will be the same.

注

If the KP Enable bit is set to '0' during key press detection, key press detection will stop immediately and all the key press/release bits will be cleared.

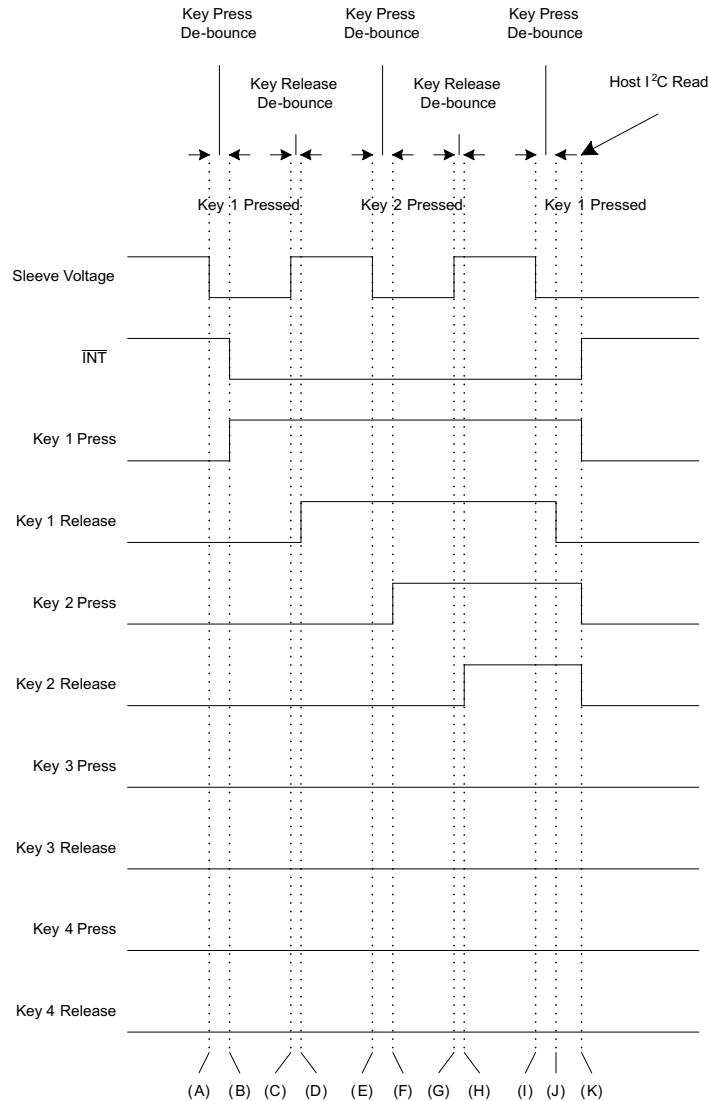

- A. The SLEEVE voltage drops below the Key Press Detection threshold and the Key Press De-bounce timer is started
- B. The end of the key press de-bounce timer. Key 1 is detected, the Key 1 Press interrupt is set and the interrupt line is asserted. The Key 1 Release interrupt is cleared.
- C. The SLEEVE voltage rises to MICBIAS as the key is released. The Key Release de-bounce timer is started.
- D. The Key Release de-bounce timer expires. The Key 1 Release bit is set and the interrupt is asserted.
- E. The SLEEVE voltage drops below the Key Press Detection threshold and the Key Press De-bounce timer is started
- F. The end of the key press de-bounce timer. Key 2 is detected, the Key 2 Press interrupt is set and the interrupt line is asserted. The Key 2 Release interrupt is cleared.
- G. The SLEEVE voltage rises to MICBIAS as the key is released. The Key Release de-bounce timer is started.
- H. The Key Release de-bounce timer expires. The Key 2 Release bit is set and the interrupt is asserted.
- I. The SLEEVE voltage drops below the Key Press Detection threshold and the Key Press De-bounce timer is started
- J. The end of the key press de-bounce timer. Key 1 is detected, the Key 1 Press interrupt is set and the interrupt line is asserted. The Key 1 Release interrupt is cleared.
- K. The host reads the I2C interrupt register and sees the following interrupts:
 - Key 1 Press
 - Key 2 Press
 - Key 2 Release

Using the pseudo-code in the key press detection section this is interpreted as:

- Key 2 was pressed one time and is not being held
- Key 1 is currently pressed, start the key press duration timer

10.2.2.4.7 Raw Data Key Press Detection

In addition to threshold adjustment the TS3A227E features the ability to utilize the internal ADC raw output with the Raw Data En bit of the Device Setting 2 register.

Notes on using the Raw ADC Output:

- Key Press/Release interrupts that have not been serviced will not be cleared upon setting the Raw Data En bit to '1'.
- By Setting the Raw Data En bit to '1' the Key Press Threshold registers will be ignored. Instead of reporting key 1 through 4 press and releases the TS3A227E will only use Key 1 Press to indicate that a key is pressed and the Key 1 Release interrupt to report that the key was released.
- The ADC Output register will only be cleared after the Raw Data En bit is cleared. The Raw Data En bit is cleared if the Key Press Enable bit is set to '0'. Consequently the ADC Output register clears if the Raw Data En bit is set to '0', the Key Press Enable bit is set to '0', or a removal event occurs. This means the ADC Output register will not clear after it is read.
- A manual software trigger can be initiated after a key was pressed to run the ADC detection again. This will not set the Key 1 Press interrupt.
- The ADC Output is updated after a Key is detected or if the manual ADC trigger bit is set to '1'. If an ADC conversion has completed the ADC Conversion interrupt bit will be set to '1' regardless if there was a software initiated trigger or if a new key press was detected.
- If the ADC has completed a conversion the output is always non 0 meaning the lowest possible detection threshold of the ADC is 01h. If the ADC Output register is 00h a conversion has not been completed or the ADC Output was cleared.

The previous section on gray zones should be applied to any bins create for the raw ADC mode.

10.2.3 Application Curves

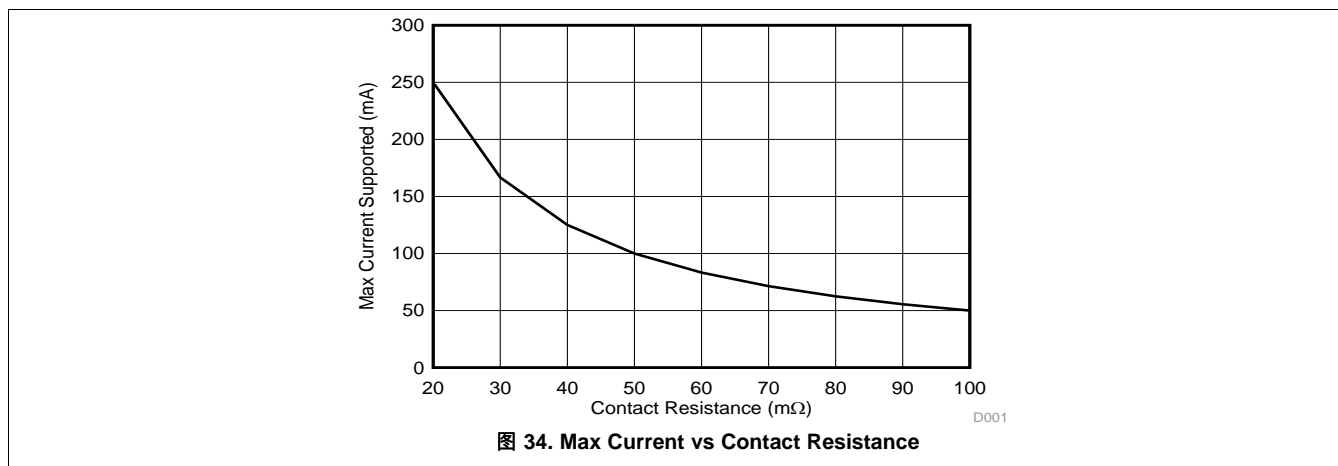

11 Power Supply Recommendations

The TS3A227E is designed to operate from an input voltage supply range between 2.5 V and 4.5 V. This input supply is recommended to be decoupled to ground via two de-coupling capacitors of 0.1µF and 1µF placed as close as possible to the TS3A227E. To ensure a POR trip during a power-down and power-on event the power supply should follow the minimum and maximum V_{DD} rise and fall times specified in the electrical specifications section.

The TS3A227E features the ability to power the digital IO pins at a different rail than the supply. This allows systems to run the TS3A227E at 3.3 V and still use a 1.8 V eliminating the need for a translator. Have the 1.8 V rail while the device is powered from a higher voltage will increase the current consumption of the device due to CMOS shoot through current. This increased supply current is documented in the electrical specifications table.

12 Layout

12.1 Layout Guidelines

- The VDD pin must have de-coupling capacitors placed as closely to the device as possible. Typically recommended capacitors are a 0.1 μF and 1 μF capacitor.
- If FM support is not needed connect GNDA to system GND along with the GND connections with the shortest connections possible.
- RING2 and SLEEVE should be routed on the same layer as the audio jack for best performance with less than 50 m Ω to the audio jack pins. These two pins should have priority in layout over other pins. It is recommended to not use vias on these traces and pair the device with an audio jack that facilitates this type of layout.
- The RING2_SENSE and SLEEVE_SENSE pins are kelvin connections to the audio jack and should be shorted to RING2 and SLEEVE as close to the audio jack as possible. If there are 0 Ω resistors between the SLEEVE/RING2 pins and the jack, connect the SENSE lines to the jack sleeve and ring2 contacts. If a microphone is connected one of the SENSE lines will carry the microphone signal and the MICBIAS supply. It is recommended that these traces not have more than 1 Ω impedance to the jack.
- Route the I²C and digital signals away from the audio signals to prevent coupling onto the audio lines.

12.2 Layout Example (QFN)



图 35. QFN Layout Example

12.3 Layout Example (DSBGA)

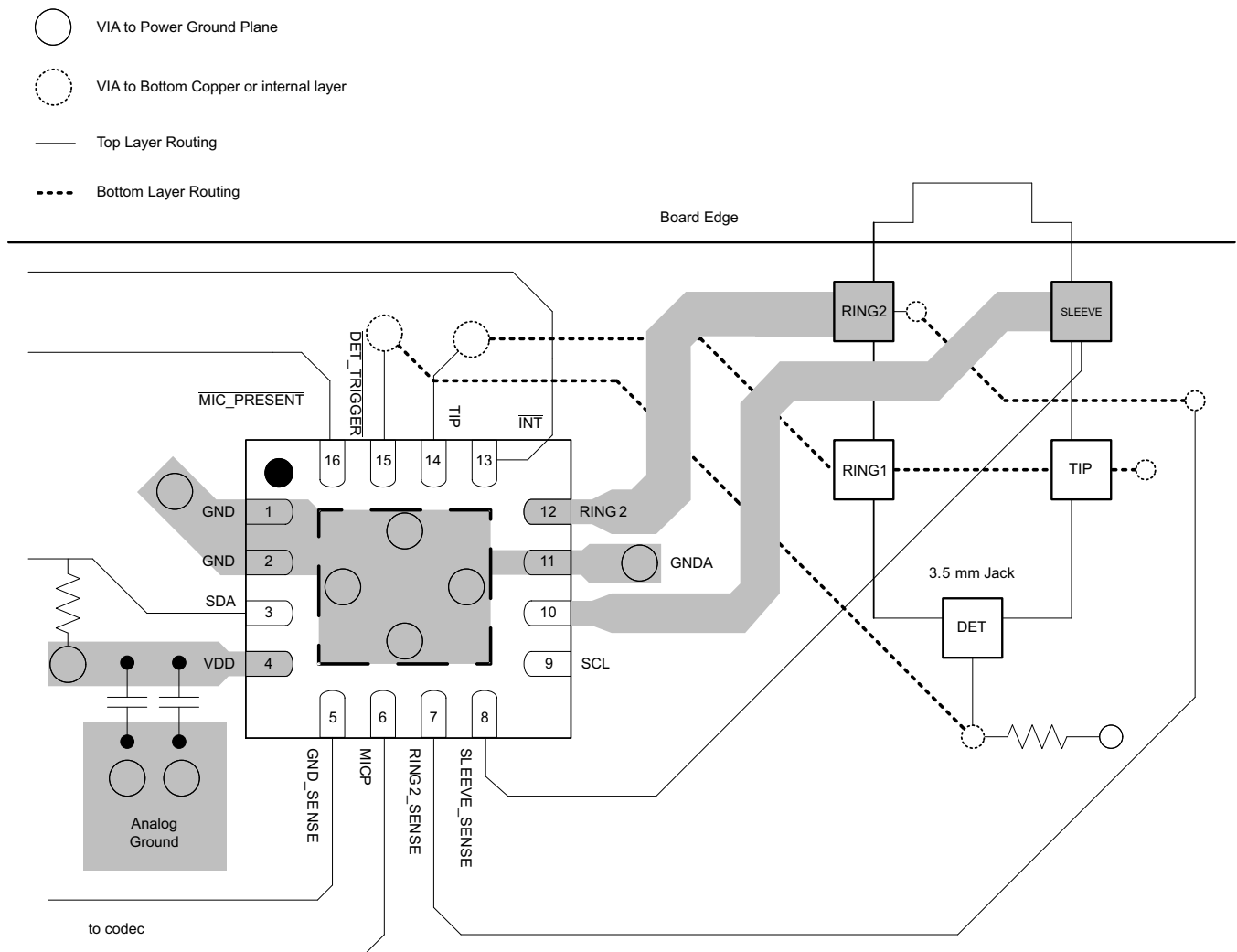

图 36. DSBGA Layout Example

13 器件和文档支持

13.1 商标

All trademarks are the property of their respective owners.

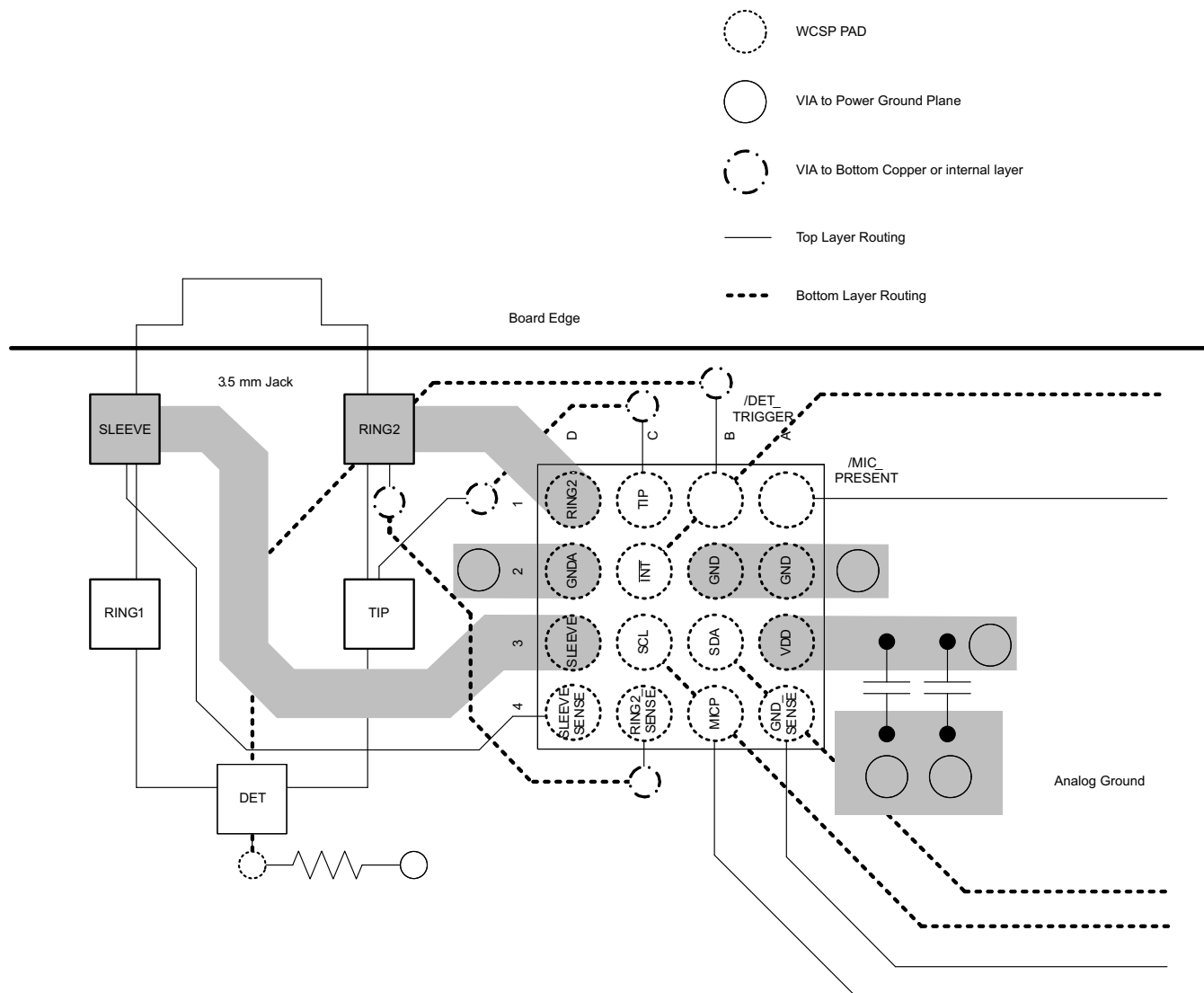
13.2 静电放电警告



这些装置包含有限的内置 ESD 保护。存储或装卸时，应将导线一起截短或将装置放置于导电泡棉中，以防止 MOS 门极遭受静电损伤。

13.3 术语表

[SLYZ022](#) — TI 术语表。

这份术语表列出并解释术语、首字母缩略词和定义。

14 机械封装和可订购信息

以下页中包括机械封装和可订购信息。 这些信息是针对指定器件可提供的最新数据。 这些数据会在无通知且不对本文档进行修订的情况下发生改变。 欲获得该数据表的浏览器版本，请查阅左侧的导航栏。

PACKAGING INFORMATION

Orderable Device	Status (1)	Package Type	Package Drawing	Pins	Package Qty	Eco Plan (2)	Lead finish/ Ball material (6)	MSL Peak Temp (3)	Op Temp (°C)	Device Marking (4/5)	Samples
TS3A227ERVAR	ACTIVE	VQFN	RVA	16	3000	RoHS & Green	NIPDAU	Level-2-260C-1 YEAR	-40 to 85	227	Samples
TS3A227EYFFR	ACTIVE	DSBGA	YFF	16	3000	RoHS & Green	SNAGCU	Level-1-260C-UNLIM	-40 to 85	227E	Samples

(1) The marketing status values are defined as follows:

ACTIVE: Product device recommended for new designs.

LIFEBUY: TI has announced that the device will be discontinued, and a lifetime-buy period is in effect.

NRND: Not recommended for new designs. Device is in production to support existing customers, but TI does not recommend using this part in a new design.

PREVIEW: Device has been announced but is not in production. Samples may or may not be available.

OBSOLETE: TI has discontinued the production of the device.

(2) **RoHS:** TI defines "RoHS" to mean semiconductor products that are compliant with the current EU RoHS requirements for all 10 RoHS substances, including the requirement that RoHS substance do not exceed 0.1% by weight in homogeneous materials. Where designed to be soldered at high temperatures, "RoHS" products are suitable for use in specified lead-free processes. TI may reference these types of products as "Pb-Free".

RoHS Exempt: TI defines "RoHS Exempt" to mean products that contain lead but are compliant with EU RoHS pursuant to a specific EU RoHS exemption.

Green: TI defines "Green" to mean the content of Chlorine (Cl) and Bromine (Br) based flame retardants meet JS709B low halogen requirements of <=1000ppm threshold. Antimony trioxide based flame retardants must also meet the <=1000ppm threshold requirement.

(3) MSL, Peak Temp. - The Moisture Sensitivity Level rating according to the JEDEC industry standard classifications, and peak solder temperature.

(4) There may be additional marking, which relates to the logo, the lot trace code information, or the environmental category on the device.

(5) Multiple Device Markings will be inside parentheses. Only one Device Marking contained in parentheses and separated by a "~" will appear on a device. If a line is indented then it is a continuation of the previous line and the two combined represent the entire Device Marking for that device.

(6) Lead finish/Ball material - Orderable Devices may have multiple material finish options. Finish options are separated by a vertical ruled line. Lead finish/Ball material values may wrap to two lines if the finish value exceeds the maximum column width.

Important Information and Disclaimer:The information provided on this page represents TI's knowledge and belief as of the date that it is provided. TI bases its knowledge and belief on information provided by third parties, and makes no representation or warranty as to the accuracy of such information. Efforts are underway to better integrate information from third parties. TI has taken and continues to take reasonable steps to provide representative and accurate information but may not have conducted destructive testing or chemical analysis on incoming materials and chemicals. TI and TI suppliers consider certain information to be proprietary, and thus CAS numbers and other limited information may not be available for release.

In no event shall TI's liability arising out of such information exceed the total purchase price of the TI part(s) at issue in this document sold by TI to Customer on an annual basis.

TAPE AND REEL INFORMATION



QUADRANT ASSIGNMENTS FOR PIN 1 ORIENTATION IN TAPE



*All dimensions are nominal

Device	Package Type	Package Drawing	Pins	SPQ	Reel Diameter (mm)	Reel Width W1 (mm)	A0 (mm)	B0 (mm)	K0 (mm)	P1 (mm)	W (mm)	Pin1 Quadrant
TS3A227ERVAR	VQFN	RVA	16	3000	330.0	12.4	3.75	3.75	1.15	8.0	12.0	Q2
TS3A227EYFFR	DSBGA	YFF	16	3000	180.0	8.4	1.94	1.94	0.69	4.0	8.0	Q1

TAPE AND REEL BOX DIMENSIONS



*All dimensions are nominal

Device	Package Type	Package Drawing	Pins	SPQ	Length (mm)	Width (mm)	Height (mm)
TS3A227ERVAR	VQFN	RVA	16	3000	367.0	367.0	35.0
TS3A227EYFFR	DSBGA	YFF	16	3000	182.0	182.0	20.0

RVA (S-PVQFN-N16)

PLASTIC QUAD FLATPACK NO-LEAD

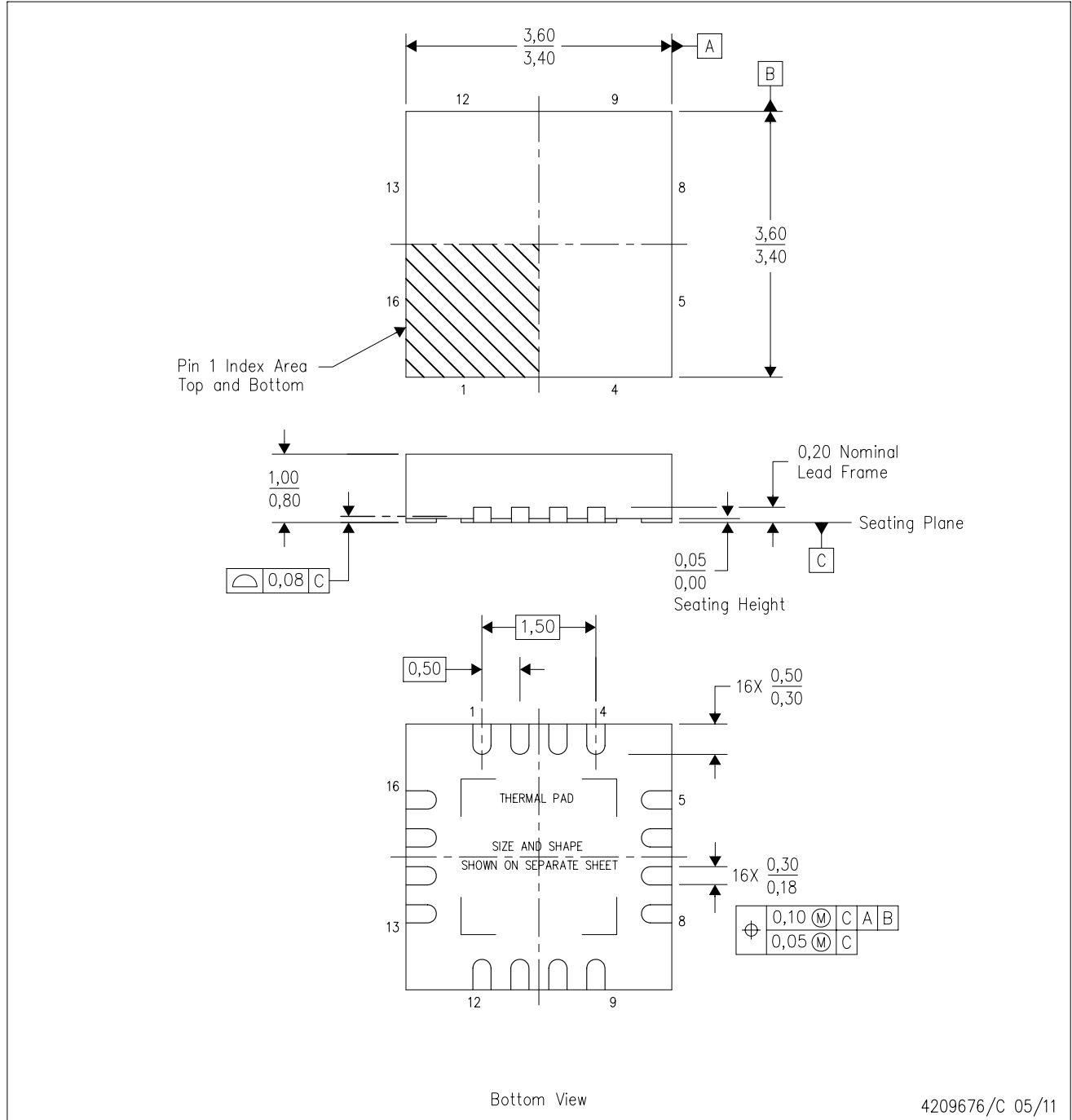

4209676/C 05/11

- NOTES:
- A. All linear dimensions are in millimeters. Dimensioning and tolerancing per ASME Y14.5M-1994.
 - B. This drawing is subject to change without notice.
 - C. QFN (Quad Flatpack No-Lead) package configuration.
 - D. The package thermal pad must be soldered to the board for thermal and mechanical performance.
 - E. See the additional figure in the Product Data Sheet for details regarding the exposed thermal pad features and dimensions.

THERMAL PAD MECHANICAL DATA

RVA (S-PVQFN-N16)

PLASTIC QUAD FLATPACK NO-LEAD

THERMAL INFORMATION

This package incorporates an exposed thermal pad that is designed to be attached directly to an external heatsink. The thermal pad must be soldered directly to the printed circuit board (PCB). After soldering, the PCB can be used as a heatsink. In addition, through the use of thermal vias, the thermal pad can be attached directly to the appropriate copper plane shown in the electrical schematic for the device, or alternatively, can be attached to a special heatsink structure designed into the PCB. This design optimizes the heat transfer from the integrated circuit (IC).

For information on the Quad Flatpack No-Lead (QFN) package and its advantages, refer to Application Report, QFN/SON PCB Attachment, Texas Instruments Literature No. SLUA271. This document is available at www.ti.com.

The exposed thermal pad dimensions for this package are shown in the following illustration.

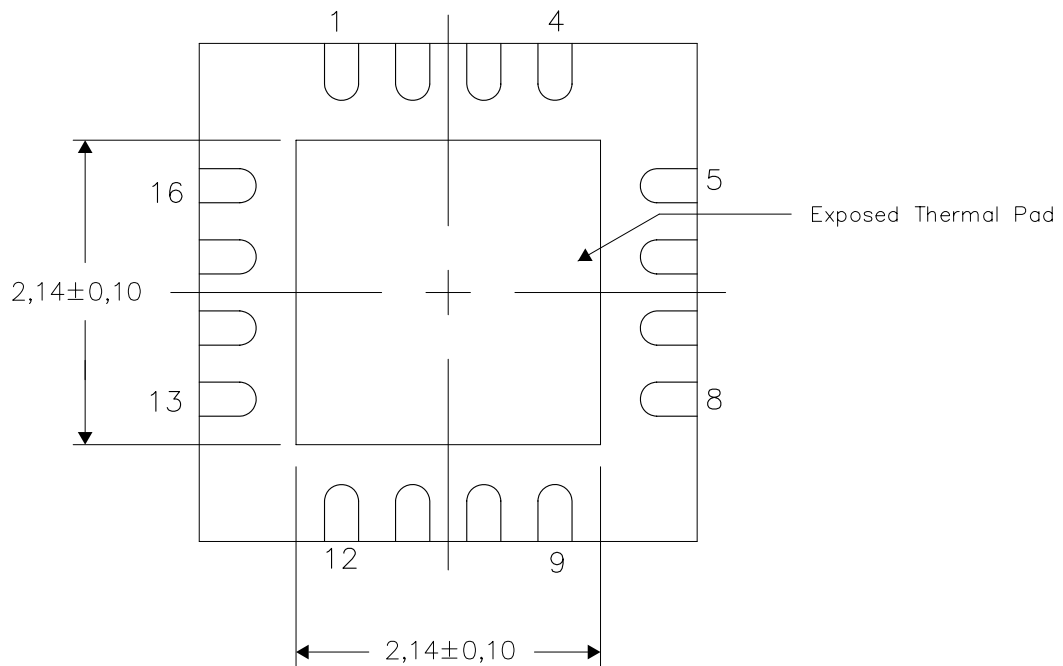

4209715/B 05/11

NOTE: All linear dimensions are in millimeters

RVA (S-PVQFN-N16)

PLASTIC QUAD FLATPACK NO-LEAD

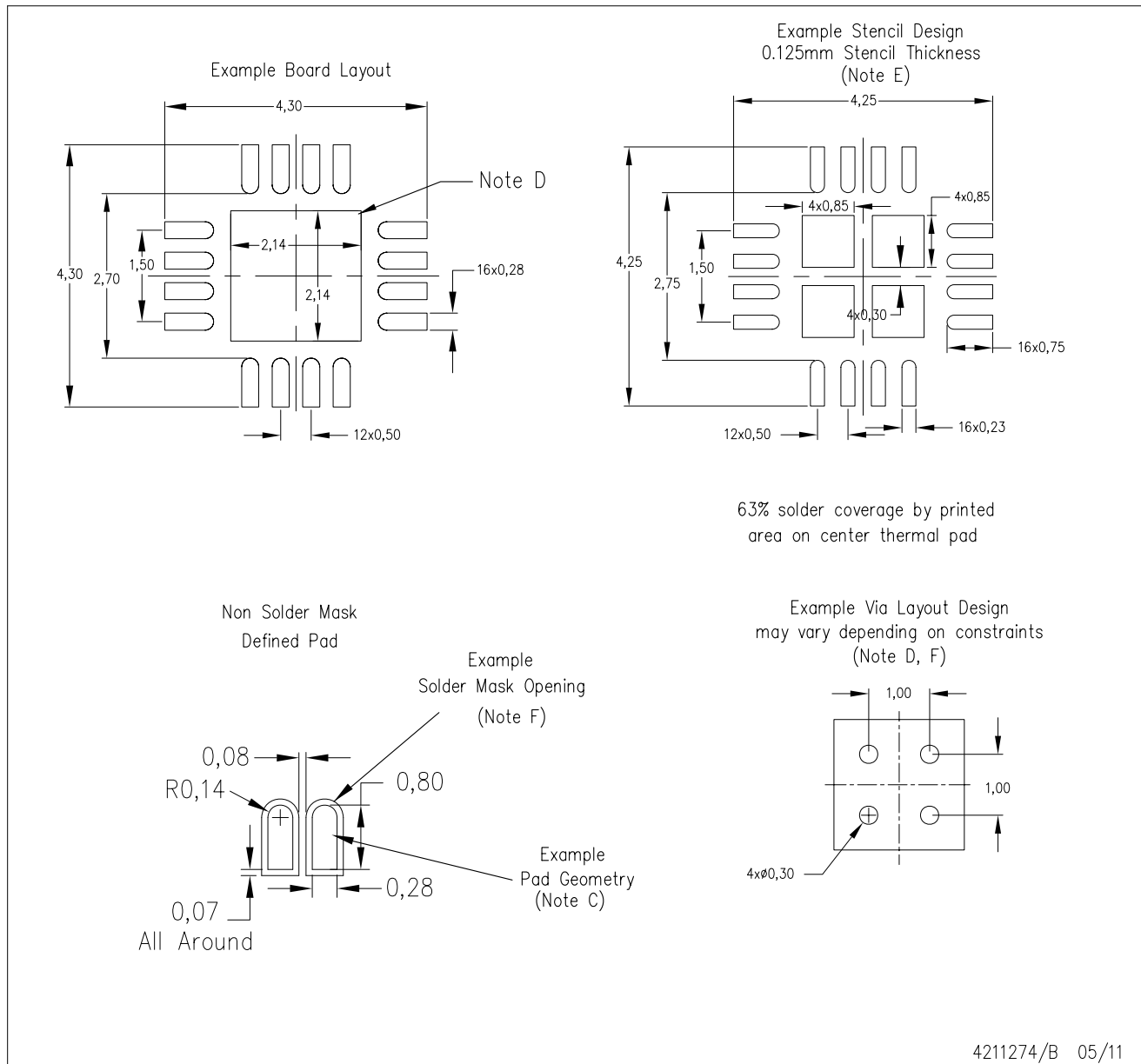

- NOTES:
- A. All linear dimensions are in millimeters.
 - B. This drawing is subject to change without notice.
 - C. Publication IPC-7351 is recommended for alternate designs.
 - D. This package is designed to be soldered to a thermal pad on the board. Refer to Application Note, Quad Flat-Pack QFN/SON PCB Attachment, Texas Instruments Literature No. SLUA271, and also the Product Data Sheets for specific thermal information, via requirements, and recommended board layout. These documents are available at www.ti.com <<http://www.ti.com>>.
 - E. Laser cutting apertures with trapezoidal walls and also rounding corners will offer better paste release. Customers should contact their board assembly site for stencil design recommendations. Refer to IPC 7525 for stencil design considerations.
 - F. Customers should contact their board fabrication site for minimum solder mask web tolerances between signal pads.

YFF0016

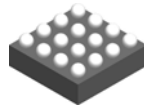

PACKAGE OUTLINE

DSBGA - 0.625 mm max height

DIE SIZE BALL GRID ARRAY

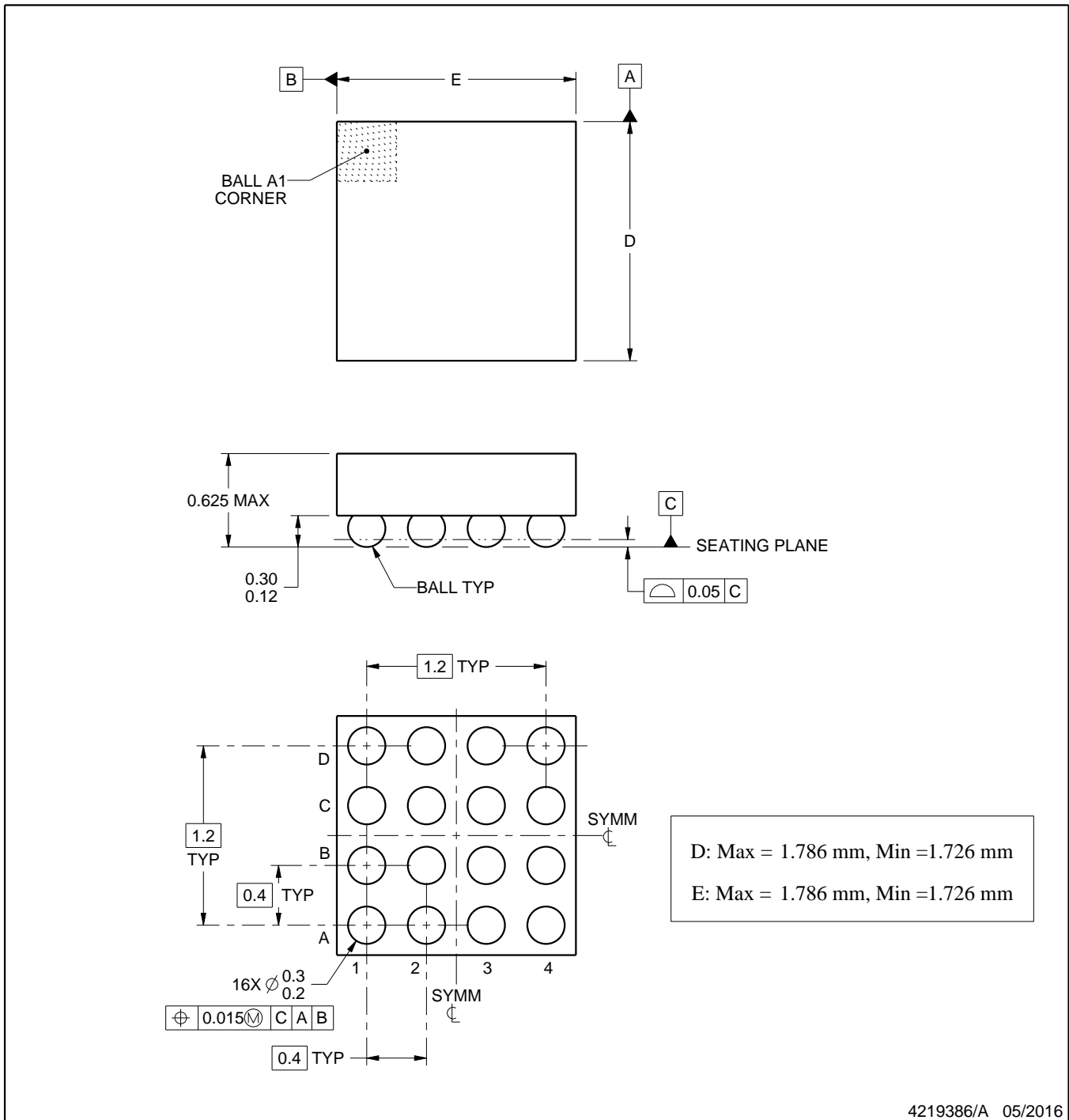

NOTES:

1. All linear dimensions are in millimeters. Any dimensions in parenthesis are for reference only. Dimensioning and tolerancing per ASME Y14.5M.
2. This drawing is subject to change without notice.

EXAMPLE BOARD LAYOUT

YFF0016

DSBGA - 0.625 mm max height

DIE SIZE BALL GRID ARRAY

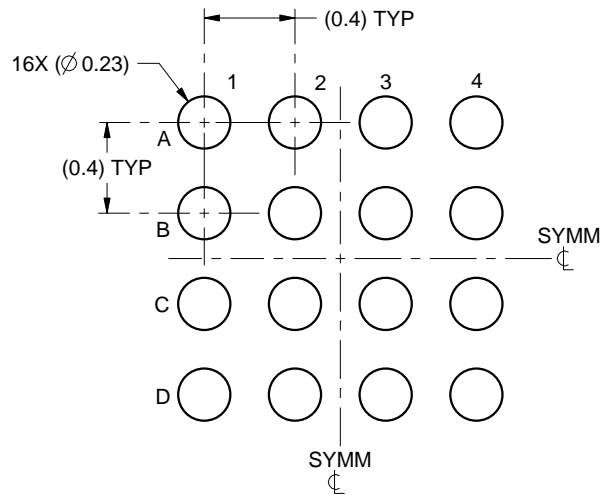

LAND PATTERN EXAMPLE
SCALE:30X



SOLDER MASK DETAILS
NOT TO SCALE

4219386/A 05/2016

NOTES: (continued)

3. Final dimensions may vary due to manufacturing tolerance considerations and also routing constraints. For more information, see Texas Instruments literature number SNVA009 (www.ti.com/lit/snva009).

EXAMPLE STENCIL DESIGN

YFF0016

DSBGA - 0.625 mm max height

DIE SIZE BALL GRID ARRAY

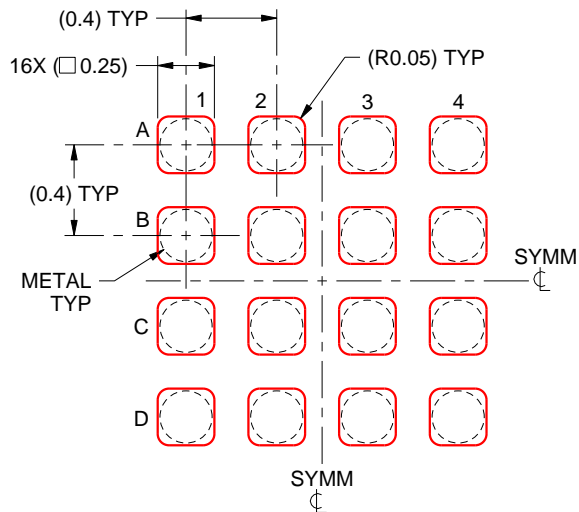

SOLDER PASTE EXAMPLE
BASED ON 0.1 mm THICK STENCIL
SCALE:30X

4219386/A 05/2016

NOTES: (continued)

4. Laser cutting apertures with trapezoidal walls and rounded corners may offer better paste release.

重要声明和免责声明

TI“按原样”提供技术和可靠性数据（包括数据表）、设计资源（包括参考设计）、应用或其他设计建议、网络工具、安全信息和其他资源，不保证没有瑕疵且不做任何明示或暗示的担保，包括但不限于对适销性、某特定用途方面的适用性或不侵犯任何第三方知识产权的暗示担保。

这些资源可供使用 TI 产品进行设计的熟练开发人员使用。您将自行承担以下全部责任：(1) 针对您的应用选择合适的 TI 产品，(2) 设计、验证并测试您的应用，(3) 确保您的应用满足相应标准以及任何其他功能安全、信息安全、监管或其他要求。

这些资源如有变更，恕不另行通知。TI 授权您仅可将这些资源用于研发本资源所述的 TI 产品的应用。严禁对这些资源进行其他复制或展示。您无权使用任何其他 TI 知识产权或任何第三方知识产权。您应全额赔偿因在这些资源的使用中对 TI 及其代表造成的任何索赔、损害、成本、损失和债务，TI 对此概不负责。

TI 提供的产品受 [TI 的销售条款](#) 或 [ti.com](#) 上其他适用条款/TI 产品随附的其他适用条款的约束。TI 提供这些资源并不会扩展或以其他方式更改 TI 针对 TI 产品发布的适用的担保或担保免责声明。

TI 反对并拒绝您可能提出的任何其他或不同的条款。

邮寄地址：Texas Instruments, Post Office Box 655303, Dallas, Texas 75265

Copyright © 2022，德州仪器 (TI) 公司