

SN74CBTLV1G125-Q1 低电压单路 FET 总线开关

1 特性

- 符合面向汽车应用的应用
 - 器件温度等级 1:
 - 40°C 至 +125°C, T_A
- 两个端口间使用 5Ω 开关连接
- 支持在数据 I/O 端口进行轨至轨开关
- I_{off} 支持局部断电模式运行

2 应用

- 呼吸机

3 说明

SN74CBTLV1G125 采用单路高速线路开关。当输出使能 (\overline{OE}) 输入为高电平时, 开关被禁用。

该器件完全适用于使用 I_{off} 的局部断电应用。I_{off} 特性确保在关断时防止损坏电流通过器件回流。该器件可在关断时提供隔离。

为了确保加电或断电期间的高阻抗状态, \overline{OE} 应通过一个上拉电阻器被连接至 V_{CC}; 该电阻器的最小值由驱动器的电流吸入能力来决定。

器件信息⁽¹⁾

订货编号	封装	封装尺寸
SN74CBTLV1G125-Q1	SOT-23 (DBV) (5)	2.90mm × 1.60mm

(1) 如需了解所有可用封装, 请参阅数据表末尾的可订购产品附录。

应用原理图

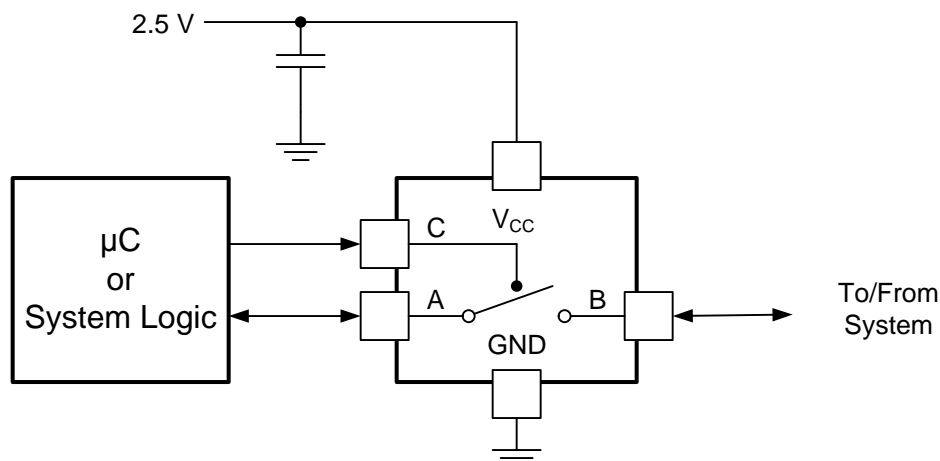

目录

1	特性	1	8.4	Device Functional Modes.....	7
2	应用	1	9	Application and Implementation	8
3	说明	1	9.1	Application Information.....	8
4	修订历史记录	2	9.2	Typical Application	8
5	Pin Configuration and Functions	3	10	Power Supply Recommendations	9
6	Specifications.....	4	11	Layout.....	9
6.1	Absolute Maximum Ratings	4	11.1	Layout Guidelines	9
6.2	ESD Ratings.....	4	11.2	Layout Example	9
6.3	Recommended Operating Conditions	4	12	器件和文档支持	10
6.4	Thermal Information	4	12.1	器件支持	10
6.5	Electrical Characteristics.....	5	12.2	接收文档更新通知	10
6.6	Switching Characteristics	5	12.3	社区资源.....	10
7	Parameter Measurement Information	6	12.4	商标.....	10
8	Detailed Description	7	12.5	静电放电警告.....	10
8.1	Overview	7	12.6	术语表	10
8.2	Functional Block Diagram	7	13	机械、封装和可订购信息.....	10
8.3	Feature Description.....	7			

4 修订历史记录

注：之前版本的页码可能与当前版本有所不同。

Changes from Revision A (December 2018) to Revision B	Page
• 将特性从“符合汽车类 应用” 更改为“符合面向汽车 应用的 AEC-Q100”.....	1
• Changed the <i>ESD Ratings</i> table notes.....	4
• Changed the T_A MAX value From: 85°C To 125°C in the <i>Recommended Operating Conditions</i>	4

Changes from Original (August 2009) to Revision A	Page
• 添加了应用列表、器件信息表、 <i>ESD</i> 额定值表、特性 说明 部分、器件功能模式、应用和实施 部分、电源建议 部分、布局部分、器件和文档支持 部分以及机械、封装和可订购信息 部分	1

5 Pin Configuration and Functions

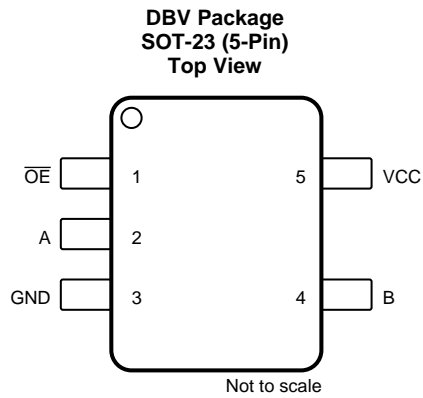

Pin Functions

PIN		I/O	DESCRIPTION
NAME	NO.		
$\overline{\text{OE}}$	1	I	Active low enable
A	2	I/O	Switch I/O
GND	3	-	Ground
B	4	I/O	Switch I/O
V _{CC}	5	-	Power Supply

6 Specifications

6.1 Absolute Maximum Ratings

over operating free-air temperature range (unless otherwise noted)⁽¹⁾

		MIN	MAX	UNIT
V _{CC}	Supply voltage range	–0.5	4.6	V
V _I	Input voltage range ⁽²⁾	–0.5	4.6	V
	Continuous channel current		128	mA
I _{IK}	Input clamp current		–50	mA
				V _{I/O} < 0
T _{stg}	Storage temperature range	–65	150	°C

- (1) Stresses beyond those listed under *Absolute Maximum Ratings* may cause permanent damage to the device. These are stress ratings only, and functional operation of the device at these or any other conditions beyond those indicated under *Recommended Operating Conditions* is not implied. Exposure to absolute-maximum-rated conditions for extended periods may affect device reliability.
- (2) The input and output negative-voltage ratings may be exceeded if the input and output clamp-current ratings are observed.

6.2 ESD Ratings

		VALUE	UNIT
V _(ESD)	Electrostatic discharge	Human-body model (HBM), per AEC Q100-002 ⁽¹⁾ HBM ESD Classification Level 2	±2000
		Charged-device model (CDM), per AEC Q100-011 CDM ESD Classification Level C5	±1000

- (1) AEC Q100-002 indicates that HBM stressing shall be in accordance with the ANSI/ESDA/JEDEC JS-001 specification.

6.3 Recommended Operating Conditions

over operating free-air temperature range (unless otherwise noted)⁽¹⁾

		MIN	MAX	UNIT
V _{CC}	Supply voltage	2.3	3.6	V
V _{IH}	High-level control input voltage	V _{CC} = 2.3 V to 2.7 V	1.7	V
		V _{CC} = 2.7 V to 3.6 V	2	
V _{IL}	Low-level control input voltage	V _{CC} = 2.3 V to 2.7 V	0.7	V
		V _{CC} = 2.7 V to 3.6 V	0.8	
T _A	Operating free-air temperature	–40	125	°C

- (1) All unused control inputs of the device must be held at V_{CC} or GND to ensure proper device operation. Refer to the TI application report, *Implications of Slow or Floating CMOS Inputs*, literature number [SCBA004](#).

6.4 Thermal Information

THERMAL METRIC ⁽¹⁾		SN74CBTLV1G125-Q1	UNIT
		SOT-23 (DBV)	
		5 PINS	
R _{θJA}	Junction-to-ambient thermal resistance	249.2	°C/W
R _{θJC(top)}	Junction-to-case (top) thermal resistance	174.2	°C/W
R _{θJB}	Junction-to-board thermal resistance	83.9	°C/W
ψ _{JT}	Junction-to-top characterization parameter	67.3	°C/W
ψ _{JB}	Junction-to-board characterization parameter	83.5	°C/W
R _{θJC(bot)}	Junction-to-case (bottom) thermal resistance	n/a	°C/W

- (1) For more information about traditional and new thermal metrics, see the [Semiconductor and IC Package Thermal Metrics](#) application report.

6.5 Electrical Characteristics

over recommended operating free-air temperature range (unless otherwise noted)

PARAMETER		TEST CONDITIONS		MIN	TYP ⁽¹⁾	MAX	UNIT
V_{IK}		$V_{CC} = 3\text{ V}$, $I_I = -18\text{ mA}$				-1.2	V
I_I		$V_{CC} = 3.6\text{ V}$, $V_I = V_{CC}$ or GND				± 1	μA
I_{off}		$V_{CC} = 0$, V_I or $V_O = 0$ to 3.6 V , $\overline{OE} = 3.6\text{ V}$				15	μA
		$V_{CC} = 0$, V_I or $V_O = 0$ to 3.6 V , $\overline{OE} = 0\text{ V}$				100	
I_{CC}		$V_{CC} = 3.6\text{ V}$, $V_I = V_{CC}$ or GND				10	μA
ΔI_{CC} ⁽²⁾	Control inputs	$V_{CC} = 3.6\text{ V}$, One input at 3 V , Other inputs at V_{CC} or GND				300	μA
C_i	Control inputs	$V_I = 3\text{ V}$ or 0				2.5	pF
$C_{io(OFF)}$		$V_O = 3\text{ V}$ or 0 , $\overline{OE} = V_{CC}$				7	pF
r_{on} ⁽³⁾	$V_{CC} = 2.3\text{ V}$, TYP at $V_{CC} = 2.5\text{ V}$	$V_I = 0$	$I_I = 32\text{ mA}$	7	10	Ω	
			$I_I = 24\text{ mA}$	7	10		
	$V_I = 1.7\text{ V}$	$I_I = 15\text{ mA}$	15	25			
		$V_I = 0$	$I_I = 32\text{ mA}$	5	7		
	$V_{CC} = 3\text{ V}$	$V_I = 0$	$I_I = 24\text{ mA}$	5	7		
			$V_I = 2.4\text{ V}$	$I_I = 15\text{ mA}$	10		15

(1) All typical values are at $V_{CC} = 3.3\text{ V}$ (unless otherwise noted), $T_A = 25^\circ\text{C}$.

(2) This is the increase in supply current for each input that is at the specified TTL voltage level, rather than V_{CC} or GND.

(3) Measured by the voltage drop between A and B terminals at the indicated current through the switch. On-state resistance is determined by the lower of the voltages of the two (A or B) terminals.

6.6 Switching Characteristics

over recommended operating free-air temperature range (unless otherwise noted) (see [Figure 1](#))

PARAMETER	FROM (INPUT)	TO (OUTPUT)	$V_{CC} = 2.5\text{ V}$ $\pm 0.2\text{ V}$		$V_{CC} = 3.3\text{ V}$ $\pm 0.3\text{ V}$		UNIT
			MIN	MAX	MIN	MAX	
t_{pd} ⁽¹⁾	A or B	B or A	0.15		0.25		ns
t_{en}	\overline{OE}	A or B	0.5	8	0.5	7.5	ns
t_{dis}	\overline{OE}	A or B	0.5	8	0.5	7.5	ns

(1) The propagation delay is the calculated RC time constant of the typical on-state resistance of the switch and the specified load capacitance of 50 pF , when driven by an ideal voltage source (zero output impedance).

7 Parameter Measurement Information

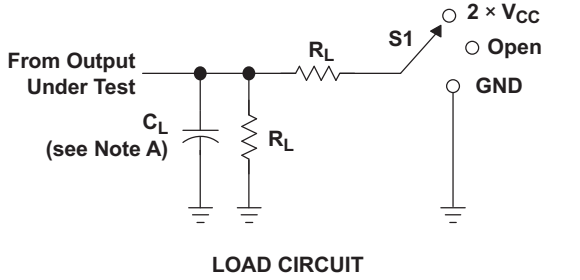

TEST	S1
t_{PLH}/t_{PHL}	Open
t_{PLZ}/t_{PZL}	$2 \times V_{CC}$
t_{PHZ}/t_{PZH}	GND

V_{CC}	C_L	R_L	V_D
$2.5\text{ V} \pm 0.2\text{ V}$	30 pF	500 Ω	0.15 V
$3.3\text{ V} \pm 0.3\text{ V}$	50 pF	500 Ω	0.3 V

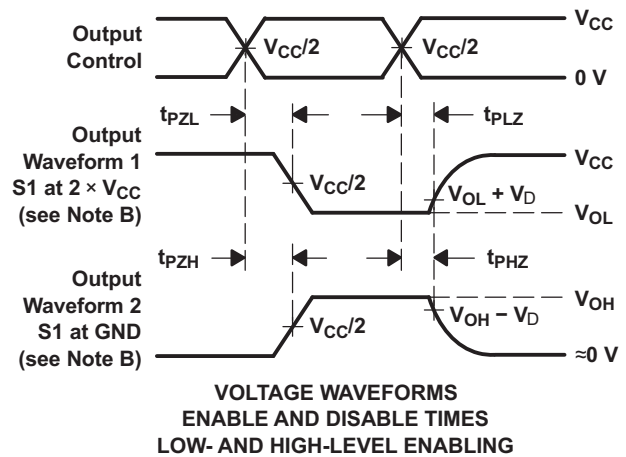
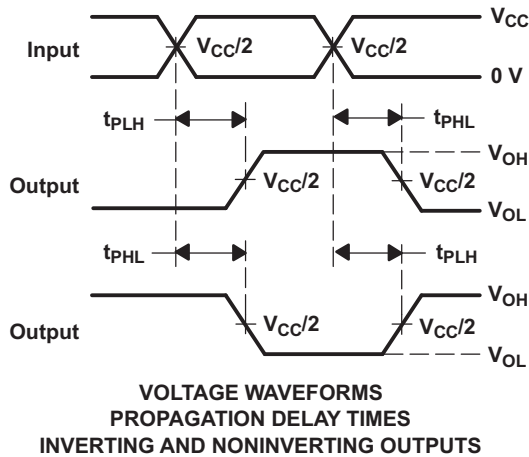
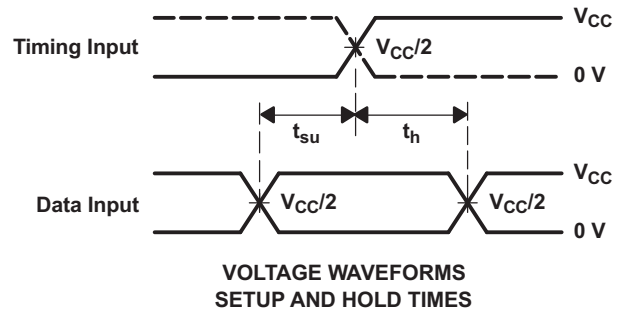
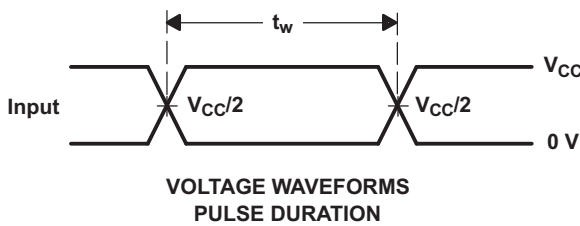

- A. C_L includes probe and jig capacitance.
- B. Waveform 1 is for an output with internal conditions such that the output is low, except when disabled by the output control.
Waveform 2 is for an output with internal conditions such that the output is high, except when disabled by the output control.
- C. All input pulses are supplied by generators having the following characteristics: $PRR \leq 10\text{ MHz}$, $Z_O = 50\ \Omega$, $t_r \leq 2\text{ ns}$, $t_f \leq 2\text{ ns}$.
- D. The outputs are measured one at a time, with one transition per measurement.
- E. t_{PLZ} and t_{PHZ} are the same as t_{dis} .
- F. t_{PZL} and t_{PZH} are the same as t_{en} .
- G. t_{PLH} and t_{PHL} are the same as t_{pd} .
- H. All parameters and waveforms are not applicable to all devices.

Figure 1. Load Circuit and Voltage Waveforms

8 Detailed Description

8.1 Overview

The SN74CBTLV1G125 device is a 1-channel 1:1 high-speed FET switch. The low ON-state resistance of the switch allows connections to be made with minimal propagation delay. The ($\overline{\text{OE}}$) pin is an active low logic control pin that controls the data flow. The FET is disabled when the output-enable ($\overline{\text{OE}}$) input is high. This device is fully specified for partial-power-down applications using I_{off} . The I_{off} feature ensures that damaging current will not backflow through the device when it is powered down. The device has isolation during power off. To ensure the high-impedance state during power up or power down, OE should be tied to VCC through a pullup resistor; the minimum value of the resistor is determined by the current-sinking capability of the driver.

8.2 Functional Block Diagram

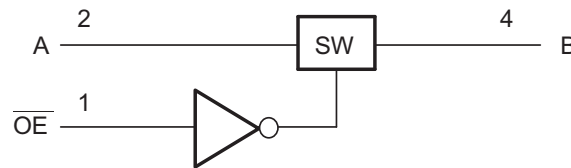

8.3 Feature Description

The SN74CBTLV1G125 features 5- Ω switch connection between ports, allowing for low signal loss across the switch. Rail-to-rail switching on data I/O allows for full voltage swing outputs. I_{off} supports partial-power-down mode operation, protecting the chip from voltages at output ports when it is not powered on.

8.4 Device Functional Modes

Table 1 shows the functional modes of SN74CBTLV1G125.

Table 1. Function Table

INPUT $\overline{\text{OE}}$	FUNCTION
L	A port = B port
H	Disconnect

9 Application and Implementation

NOTE

Information in the following applications sections is not part of the TI component specification, and TI does not warrant its accuracy or completeness. TI's customers are responsible for determining suitability of components for their purposes. Customers should validate and test their design implementation to confirm system functionality.

9.1 Application Information

The SN74CBTLV1G125 can be used to switch a signal path. The switch is bidirectional, so the A and B pins can be used as either inputs or outputs. This switch is typically used when there is one signal path that needs to be isolated at certain times.

9.2 Typical Application

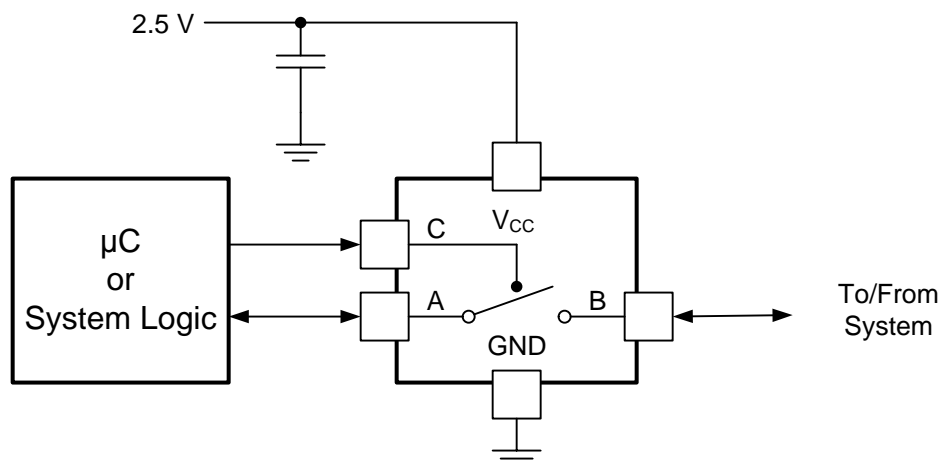

Figure 2. Typical Application

9.2.1 Design Requirements

The SN74CBTLV1G125 device can be properly operated without any external components. TI recommends pulling up the digital control pin (OE) to VCC or pulling down to GND to avoid undesired switch positions that could result from the floating pin. A floating digital pin could cause excess current consumption refer to [Implications of Slow or Floating CMOS Inputs](#).

9.2.2 Detailed Design Procedure

When \overline{OE} is high, the active bus. This means that there is a low impedance path between the A and B pins. The 0.1- μ F capacitor on VCC is a decoupling capacitor and should be placed as close as possible to the device.

10 Power Supply Recommendations

The power supply can be any voltage between the minimum and maximum supply voltage rating listed in the Recommended Operating Conditions table. Each VCC terminal should have a good bypass capacitor to prevent power disturbance. For devices with a single supply, a 0.1- μ F bypass capacitor is recommended. If multiple pins are labeled VCC, then a 0.01- μ F or 0.022- μ F capacitor is recommended for each VCC because the VCC pins are tied together internally. For devices with dual supply pins operating at different voltages, for example VCC and VDD, a 0.1- μ F bypass capacitor is recommended for each supply pin. To reject different frequencies of noise, use multiple bypass capacitors in parallel. Capacitors with values of 0.1 μ F and 1 μ F are commonly used in parallel. The bypass capacitor should be installed as close to the power terminal as possible for best results.

11 Layout

11.1 Layout Guidelines

Reflections and matching are closely related to the loop antenna theory but are different enough to be discussed separately from the theory. When a PCB trace turns a corner at a 90° angle, a reflection can occur. A reflection occurs primarily because of the change of width of the trace. At the apex of the turn, the trace width increases to 1.414 times the width. This increase upsets the transmission-line characteristics, especially the distributed capacitance and self-inductance of the trace which results in the reflection. Not all PCB traces can be straight, and therefore; some traces must turn corners. Figure 3 shows progressively better techniques of rounding corners. Only the last example (BEST) maintains constant trace width and minimizes reflections.

11.2 Layout Example

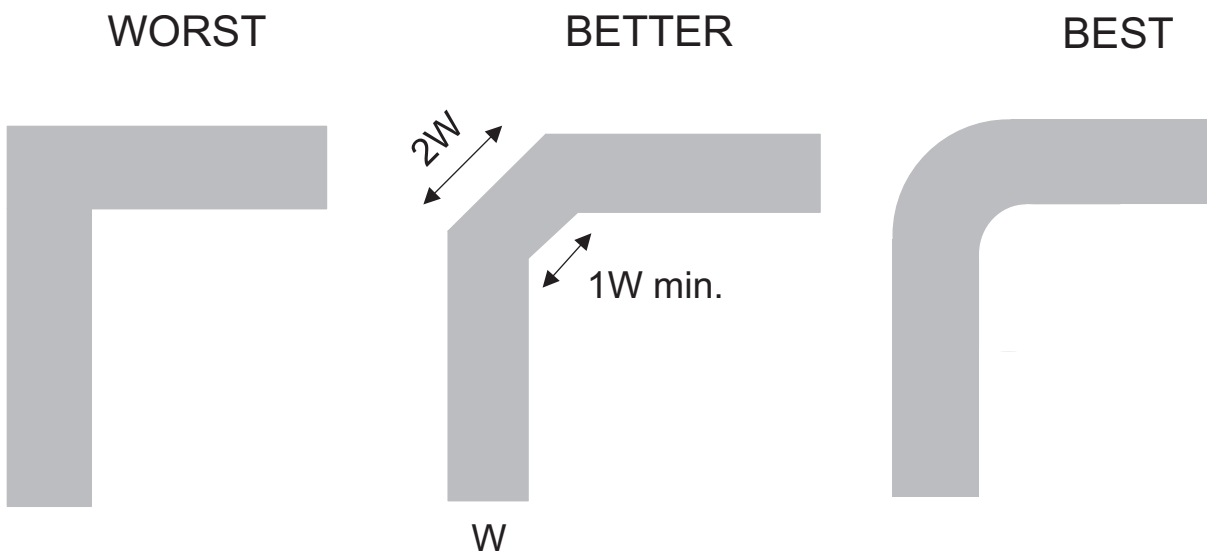

Figure 3. Example Layout

12 器件和文档支持

12.1 器件支持

12.2 接收文档更新通知

要接收文档更新通知，请导航至 TI.com.cn 上的器件产品文件夹。单击右上角的 [通知我](#) 进行注册，即可每周接收产品信息更改摘要。有关更改的详细信息，请查看任何已修订文档中包含的修订历史记录。

12.3 社区资源

下列链接提供到 TI 社区资源的连接。链接的内容由各个分销商“按照原样”提供。这些内容并不构成 TI 技术规范，并且不一定反映 TI 的观点；请参阅 TI 的 [《使用条款》](#)。

TI E2E™ 在线社区 *TI 的工程师对工程师 (E2E) 社区*。此社区的创建目的在于促进工程师之间的协作。在 e2e.ti.com 中，您可以咨询问题、分享知识、拓展思路并与同行工程师一道帮助解决问题。

设计支持 *TI 参考设计支持* 可帮助您快速查找有帮助的 E2E 论坛、设计支持工具以及技术支持的联系信息。

12.4 商标

E2E is a trademark of Texas Instruments.

12.5 静电放电警告



ESD 可能会损坏该集成电路。德州仪器 (TI) 建议通过适当的预防措施处理所有集成电路。如果不遵守正确的处理措施和安装程序，可能会损坏集成电路。

ESD 的损坏小至导致微小的性能降级，大至整个器件故障。精密的集成电路可能更容易受到损坏，这是因为非常细微的参数更改都可能会导致器件与其发布的规格不相符。

12.6 术语表

[SLYZ022](#) — *TI 术语表*。

这份术语表列出并解释术语、缩写和定义。

13 机械、封装和可订购信息

以下页面包含机械、封装和可订购信息。这些信息是指定器件的最新可用数据。数据如有变更，恕不另行通知，且不会对此文档进行修订。如需获取此数据表的浏览器版本，请查阅左侧的导航栏。

PACKAGING INFORMATION

Orderable Device	Status (1)	Package Type	Package Drawing	Pins	Package Qty	Eco Plan (2)	Lead finish/ Ball material (6)	MSL Peak Temp (3)	Op Temp (°C)	Device Marking (4/5)	Samples
74CBTLV1G125DBVRQ1	ACTIVE	SOT-23	DBV	5	3000	RoHS & Green	NIPDAU	Level-1-260C-UNLIM	-40 to 125	VCTO	Samples

(1) The marketing status values are defined as follows:

ACTIVE: Product device recommended for new designs.

LIFEBUY: TI has announced that the device will be discontinued, and a lifetime-buy period is in effect.

NRND: Not recommended for new designs. Device is in production to support existing customers, but TI does not recommend using this part in a new design.

PREVIEW: Device has been announced but is not in production. Samples may or may not be available.

OBSOLETE: TI has discontinued the production of the device.

(2) **RoHS:** TI defines "RoHS" to mean semiconductor products that are compliant with the current EU RoHS requirements for all 10 RoHS substances, including the requirement that RoHS substance do not exceed 0.1% by weight in homogeneous materials. Where designed to be soldered at high temperatures, "RoHS" products are suitable for use in specified lead-free processes. TI may reference these types of products as "Pb-Free".

RoHS Exempt: TI defines "RoHS Exempt" to mean products that contain lead but are compliant with EU RoHS pursuant to a specific EU RoHS exemption.

Green: TI defines "Green" to mean the content of Chlorine (Cl) and Bromine (Br) based flame retardants meet JS709B low halogen requirements of <=1000ppm threshold. Antimony trioxide based flame retardants must also meet the <=1000ppm threshold requirement.

(3) MSL, Peak Temp. - The Moisture Sensitivity Level rating according to the JEDEC industry standard classifications, and peak solder temperature.

(4) There may be additional marking, which relates to the logo, the lot trace code information, or the environmental category on the device.

(5) Multiple Device Markings will be inside parentheses. Only one Device Marking contained in parentheses and separated by a "-" will appear on a device. If a line is indented then it is a continuation of the previous line and the two combined represent the entire Device Marking for that device.

(6) Lead finish/Ball material - Orderable Devices may have multiple material finish options. Finish options are separated by a vertical ruled line. Lead finish/Ball material values may wrap to two lines if the finish value exceeds the maximum column width.

Important Information and Disclaimer: The information provided on this page represents TI's knowledge and belief as of the date that it is provided. TI bases its knowledge and belief on information provided by third parties, and makes no representation or warranty as to the accuracy of such information. Efforts are underway to better integrate information from third parties. TI has taken and continues to take reasonable steps to provide representative and accurate information but may not have conducted destructive testing or chemical analysis on incoming materials and chemicals. TI and TI suppliers consider certain information to be proprietary, and thus CAS numbers and other limited information may not be available for release.

In no event shall TI's liability arising out of such information exceed the total purchase price of the TI part(s) at issue in this document sold by TI to Customer on an annual basis.

TAPE AND REEL INFORMATION



QUADRANT ASSIGNMENTS FOR PIN 1 ORIENTATION IN TAPE



*All dimensions are nominal

Device	Package Type	Package Drawing	Pins	SPQ	Reel Diameter (mm)	Reel Width W1 (mm)	A0 (mm)	B0 (mm)	K0 (mm)	P1 (mm)	W (mm)	Pin1 Quadrant
74CBTLV1G125DBVRQ1	SOT-23	DBV	5	3000	179.0	8.4	3.2	3.2	1.4	4.0	8.0	Q3

TAPE AND REEL BOX DIMENSIONS



*All dimensions are nominal

Device	Package Type	Package Drawing	Pins	SPQ	Length (mm)	Width (mm)	Height (mm)
74CBTLV1G125DBVRQ1	SOT-23	DBV	5	3000	200.0	183.0	25.0

EXAMPLE STENCIL DESIGN

DBV0005A

SOT-23 - 1.45 mm max height

SMALL OUTLINE TRANSISTOR



SOLDER PASTE EXAMPLE
BASED ON 0.125 mm THICK STENCIL
SCALE:15X

4214839/F 06/2021

NOTES: (continued)

7. Laser cutting apertures with trapezoidal walls and rounded corners may offer better paste release. IPC-7525 may have alternate design recommendations.
8. Board assembly site may have different recommendations for stencil design.

重要声明和免责声明

TI“按原样”提供技术和可靠性数据（包括数据表）、设计资源（包括参考设计）、应用或其他设计建议、网络工具、安全信息和其他资源，不保证没有瑕疵且不做任何明示或暗示的担保，包括但不限于对适销性、某特定用途方面的适用性或不侵犯任何第三方知识产权的暗示担保。

这些资源可供使用 TI 产品进行设计的熟练开发人员使用。您将自行承担以下全部责任：(1) 针对您的应用选择合适的 TI 产品，(2) 设计、验证并测试您的应用，(3) 确保您的应用满足相应标准以及任何其他功能安全、信息安全、监管或其他要求。

这些资源如有变更，恕不另行通知。TI 授权您仅可将这些资源用于研发本资源所述的 TI 产品的应用。严禁对这些资源进行其他复制或展示。您无权使用任何其他 TI 知识产权或任何第三方知识产权。您应全额赔偿因在这些资源的使用中对 TI 及其代表造成的任何索赔、损害、成本、损失和债务，TI 对此概不负责。

TI 提供的产品受 [TI 的销售条款](#) 或 [ti.com](#) 上其他适用条款/TI 产品随附的其他适用条款的约束。TI 提供这些资源并不会扩展或以其他方式更改 TI 针对 TI 产品发布的适用的担保或担保免责声明。

TI 反对并拒绝您可能提出的任何其他或不同的条款。

邮寄地址：Texas Instruments, Post Office Box 655303, Dallas, Texas 75265
Copyright © 2021，德州仪器 (TI) 公司