

bq25071-Q1 采用 50mA LDO 的汽车级 1A、单节 LiFePO₄ 线性电池充电器

1 特性

- 适用于汽车电子应用
- 具有符合 AEC-Q100 标准的下列结果：
 - 器件温度 1 级：-40°C 至 125°C 的环境运行温度范围
 - 器件人体放电模式 (HBM) 静电放电 (ESD) 分类等级 H2
 - 器件组件充电模式 (CDM) ESD 分类等级 C5
- 单节 LiFePO₄ 充电算法
- 30V 额定输入电压，具有 10.5V 过压保护 (OVP)
- 50mA 集成低压降线性稳压器 (LDO)
- 可编程充电电流（通过 ISET 和 EN 端子编程）
- 热调节和保护
- 软启动特性可降低浪涌电流
- 电池负温度系数 (NTC) 监视
- 充电状态指示
- 具有可湿性侧面的 10 引脚小外形尺寸无引线 (SON) (2mm × 3mm) 封装

2 应用

- 汽车用紧急呼叫
- 汽车远程信息处理
- 车辆全球定位系统 (GPS) 跟踪
- 车载网络视频摄像机
- 智能钥匙
- 汽车娱乐备用电池

3 说明

bq25071-Q1 是一款高度集成的 LiFePO₄ 线性电池充电器，面向空间受限的汽车应用。该器件由 USB 端口或交流适配器供电，并为单节 LiFePO₄ 电池提供高达 1A 的充电电流。30V 的额定输入电压支持未经稳压的低成本适配器。

bq25071-Q1 具有一个电源输出，可在对电池充电的同时为系统供电。输入电流既可通过 ISET 输入编程设定在 100mA 至 1A 范围内，也可以在 USB500 模式下配置。另外，IC 中还集成了一个 4.9V ±10% 50mA LDO，用于为低功耗外部电路供电。

LiFePO₄ 充电算法可消除锂电池充电周期中所用的恒压模式控制下常见的电流逐渐减小过程，可大幅缩短充电时间。在这种情况下，电池将快速充电至过充电电压，然后降至较低的浮充电压阈值。该充电器集成了具有充电电流和电压感应功能的功率级，可在电流和电压调节环路中获得高级别的精度。内部控制环路可在整个充电周期内监视 IC 结温，并在温度超过内部温度阈值时减小充电电流。

器件信息 (1)

部件号	封装	封装尺寸 (标称值)
bq25071-Q1	WSO (10)	2.00mm x 3.00mm

(1) 如需了解所有可用封装，请见数据表末尾的可订购产品附录。

应用电路原理图

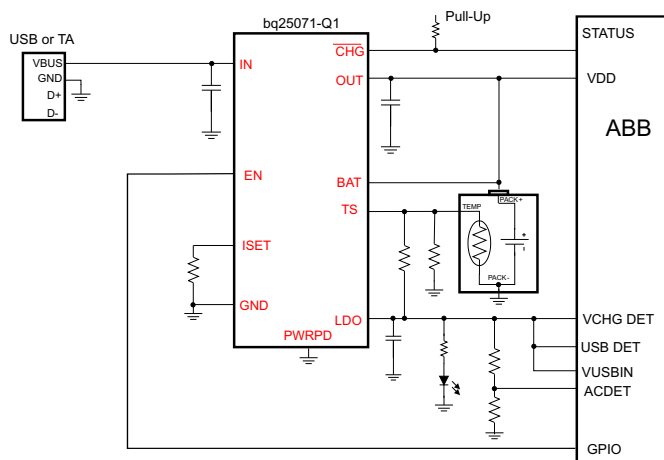

Copyright © 2016, Texas Instruments Incorporated



目录

1	特性	1	8.2	Functional Block Diagram	10
2	应用	1	8.3	Feature Description	11
3	说明	1	8.4	Device Functional Modes	13
4	修订历史记录	2	9	Application and Implementation	15
5	Device Comparison Table	3	9.1	Application Information	15
6	Pin Configuration and Functions	3	9.2	Typical Application	15
7	Specifications	4	9.3	System Examples	17
7.1	Absolute Maximum Ratings	4	10	Power Supply Recommendations	18
7.2	ESD Ratings	4	11	Layout	18
7.3	Recommended Operating Conditions	4	11.1	Layout Guidelines	18
7.4	Thermal Information	4	11.2	Layout Example	18
7.5	Electrical Characteristics	5	12	器件和文档支持	19
7.6	Timing Requirements	6	12.1	社区资源	19
7.7	Typical Characteristics	7	12.2	商标	19
7.8	Typical Characteristics	8	12.3	静电放电警告	19
8	Detailed Description	9	12.4	Glossary	19
8.1	Overview	9	13	机械、封装和可订购信息	19

4 修订历史记录

日期	修订版本	注释
2016 年 4 月	*	最初发布版本。

5 Device Comparison Table

PART NUMBER	$V_{BAT(OVCH)}$	$V_{BAT(FLOAT)}$	$V_{(OVP)}$	$V_{(LDO)}$
bq25071QWDQCRQ1	3.7 V	3.5 V	10.5 V	4.9 V
bq25071QWDQCTQ1	3.7 V	3.5 V	10.5 V	4.9 V

6 Pin Configuration and Functions

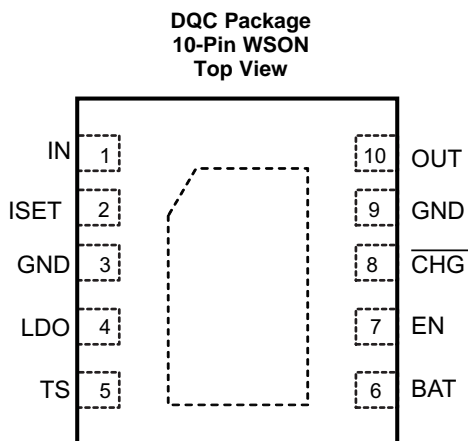

Pin Functions

PIN		I/O	DESCRIPTION
NAME	NO.		
IN	1	I	Input power supply. IN is connected to the external DC supply (AC adapter or USB port). Bypass IN to GND with at least a 0.1 μ F ceramic capacitor.
ISET	2	O	Input current programming bias pin. Connect a resistor from ISET to GND to program the input current limit when the user programmable mode is selected by grounding the EN pin. The resistor range is between 1 k Ω and 10 k Ω to set the current between 100 mA and 1 A.
GND	3, 9	–	Ground pin. Connect to the thermal pad and the ground plane of the circuit.
LDO	4	O	LDO output. LDO is regulated to 4.9V and drives up to 50 mA. Bypass LDO to GND with a 0.1 μ F ceramic capacitor. LDO is enabled when $V_{(UVLO)} < V_{IN} < V_{(OVP)}$.
TS	5	I	Battery pack NTC monitoring input. Connect a resistor divider from LDO to GND with TS connected to the center tap to set the charge temperature window. The battery pack NTC is connected in parallel with the bottom resistor of the divider. See the Detailed Design Procedure section for details on the selecting the proper component values.
BAT	6	I	BAT is the sense input for the battery voltage. Connect BAT and OUT to the battery.
EN	7	I	Enable input. Drive EN high to disable the IC. Connect EN to GND to place the bq25071-Q1Q in the user programmable mode using the ISET input where the input current is programmed. Leave EN floating to place the bq25071-Q1Q in USB500 mode. See the Input Current Limit Control (EN) section for details on using the EN interface.
\overline{CHG}	8	O	Charge status indicator open-drain output. \overline{CHG} is pulled low while the device is charging the battery. \overline{CHG} goes high impedance when the battery is fully charged.
OUT	10	O	System output connection. Bypass the OUT to GND with a 1 μ F ceramic capacitor. Connect OUT and BAT together.
Thermal Pad	Pad	–	There is an internal electrical connection between the exposed thermal pad and the GND pin of the device. The thermal pad must be connected to the same potential as the GND pin on the printed circuit board. Do not use the thermal pad as the primary ground input for the device. GND pin must be connected to ground at all times.

7 Specifications

7.1 Absolute Maximum Ratings ⁽¹⁾

over operating free-air temperature range (unless otherwise noted)

		MIN	MAX	UNIT
Input Voltage	IN (with respect to GND)	-0.3	30	V
	EN, TS (with respect to GND)	-0.3	7	V
Output Voltage	BAT, OUT, LDO, $\overline{\text{CHG}}$, ISET (with respect to GND)	-0.3	7	V
Input Current (Continuous)	IN		1.2	A
Output Current (Continuous)	BAT		1.2	A
Output Current (Continuous)	LDO		100	mA
Output Sink Current	$\overline{\text{CHG}}$		5	mA
Junction temperature, T_J		-40	150	°C
Storage temperature, T_{STG}		-65	150	°C

- (1) Stresses beyond those listed under *absolute maximum ratings* may cause permanent damage to the device. These are stress ratings only, and functional operation of the device at these or any other conditions beyond those indicated under *recommended operating conditions* is not implied. Exposure to absolute-maximum-rated conditions for extended periods may affect device reliability. All voltage values are with respect to the network ground pin unless otherwise noted.

7.2 ESD Ratings

		VALUE	UNIT
$V_{(ESD)}$ Electrostatic discharge	Human-body model (HBM), per aec q100-002 ⁽¹⁾	±3000	V
	Charged-device model (CDM), per AEC Q100-011	±1000	

- (1) AEC Q100-002 indicates that HBM stressing shall be in accordance with the ANSI/ESDA/JEDEC JS-001 specification.

7.3 Recommended Operating Conditions

		MIN	MAX	UNITS
V_{IN}	IN operating voltage	3.75 ₍₁₎	8	V
I_{IN}	Input current, IN		1	A
I_{OUT}	Output Current in charge mode, OUT		1	A
T_J	Junction Temperature	-40	125	°C

- (1) Charge current may be limited at low input voltages due to the dropout of the device.

7.4 Thermal Information

THERMAL METRIC ⁽¹⁾		bq25071-Q1	UNIT
		DQC (WSON)	
		10 PINS	
$R_{\theta JA}$	Junction-to-ambient thermal resistance	61.6	°C/W
$R_{\theta JC(top)}$	Junction-to-case (top) thermal resistance	65.5	
$R_{\theta JB}$	Junction-to-board thermal resistance	22.8	
Ψ_{JT}	Junction-to-top characterization parameter	1.5	
Ψ_{JB}	Junction-to-board characterization parameter	22.7	
$R_{\theta JC(bot)}$	Junction-to-case (bottom) thermal resistance	5.5	

- (1) For more information about traditional and new thermal metrics, see the IC Package Thermal Metrics application report, [SPRA953](#).

7.5 Electrical Characteristics

Over junction temperature range $-40^{\circ}\text{C} \leq T_J \leq 125^{\circ}\text{C}$ and recommended supply voltage (unless otherwise noted)

PARAMETER		TEST CONDITIONS	MIN	TYP	MAX	UNITS
INPUT						
$V_{(UVLO)}$	Under-voltage lock-out	$V_{IN}: 0\text{ V} \rightarrow 4\text{ V}$	3.15	3.30	3.55	V
$V_{HYS(UVLO)}$	Hysteresis on $V_{(UVLO)}$	$V_{IN}: 4\text{ V} \rightarrow 0\text{ V}$		300		mV
$V_{IN(SLP)}$	Valid input source threshold $V_{IN(SLP)}$ above V_{BAT}	Input power good if $V_{IN} > V_{BAT} + V_{IN(SLP)}$ $V_{(BAT)} = 3.6\text{ V}$, $V_{IN}: 3.5\text{ V} \rightarrow 4\text{ V}$	30	75	150	mV
		Input power good if $V_{IN} > V_{BAT} + V_{IN(SLP)}$ $V_{(BAT)} = 3.6\text{ V}$, $V_{IN}: 4\text{ V} \rightarrow 3.5\text{ V}$	24	55	95	mV
$V_{HYS(INSLP)}$	Hysteresis on $V_{IN(SLP)}$	$V_{(BAT)} = 3.6\text{ V}$, $V_{IN}: 4\text{ V} \rightarrow 3.5\text{ V}$		32		mV
V_{OVP}	Input over-voltage protection threshold	$V_{IN}: 5\text{ V} \rightarrow 11\text{ V}$	10.2	10.5	10.8	V
$V_{HYS(OVP)}$	Hysteresis on OVP	$V_{IN}: 11\text{ V} \rightarrow 5\text{ V}$		100		mV
QUIESCENT CURRENT						
$I_{BAT(PDWN)}$	Battery current into BAT, No input connected	$V_{IN} = 0\text{ V}$ ⁽¹⁾ , $V_{(CHG)} = \text{Low}$			6	μA
$I_{IN(STDBY)}$	Standby current into IN pin	$\text{EN} = \text{HI}$, $V_{IN} = 5.5\text{V}$			0.25	mA
		$\text{EN} = \text{HI}$, $V_{IN} \leq V_{(OVP)}$			0.5	
		$\text{EN} = \text{HI}$, $V_{IN} > V_{(OVP)}$			2	
BATTERY CHARGER FAST-CHARGE						
$V_{BAT(REG)}$	Battery charge regulation voltage	$T_A = -40^{\circ}\text{C}$ to 125°C , $I_{OUT} = 50\text{ mA}$, $V_{IN} = 5\text{ V}$	3.455	3.5	3.545	V
		$T_A = 25^{\circ}\text{C}$, $V_{IN} = 5\text{ V}$, $I_{OUT} = 50\text{ mA}$	3.455	3.5	3.539	
$V_{BAT(OVCH)}$	Battery overcharge voltage threshold		3.55	3.7	3.81	V
$I_{IN(RANGE)}$	User programmable input current limit range	$R_{(ISET)} = 1\text{ k}\Omega$ to $10\text{ k}\Omega$, $\text{EN} = V_{SS}$	100		1000	mA
$I_{IN(LIM)}$	Input current limit, or fast-charge current	$\text{EN} = \text{FLOAT}$	435	467	500	mA
		$\text{EN} = V_{SS}$	K_{ISET}/R_{ISET}			
K_{ISET}	Fast charge current factor $T_A \leq 85^{\circ}\text{C}$	$R_{(ISET)} = 1\text{ k}\Omega$ to $10\text{ k}\Omega$, $\text{EN} = V_{SS}$, $4.35\text{ V} < V_{IN} \leq 8\text{ V}$	860	1000	1130	A Ω
		$R_{(ISET)} = 1\text{ k}\Omega$ to $10\text{ k}\Omega$, $\text{EN} = V_{SS}$, $3.75\text{ V} < V_{IN} \leq 4.35\text{ V}$	815	1000	1185	A Ω
$V_{DO(IN-OUT)}$	$V_{IN} - V_{OUT}$	$V_{IN} = 4.2\text{ V}$, $I_{OUT} = 0.75\text{ A}$		500	900	mV
ISET SHORT CIRCUIT PROTECTION						
$R_{ISET(MAX)}$	Highest resistor value considered a short fault	$R_{(ISET)}: 900\ \Omega \rightarrow 300\ \Omega$, I_{OUT} latches off, Cycle power to reset, Fault range $> 1.10\text{ A}$			720	Ω
$I_{OUT(CL)}$	Maximum OUT current limit regulation (Clamp)		1		2	A
PRE-CHARGE AND CHARGE DONE						
$V_{(LOWV)}$	Pre-charge to fast-charge transition threshold		0.5	0.7	0.9	V
$I_{(PRECHARGE)}$	Precharge current to BAT during precharge mode	$V_{(BAT)} = 0\text{ V}$ to 0.7 V	41.5	45	49.5	mA
RECHARGE OR REFRESH						
$V_{(RCH)}$	Recharge detection threshold hysteresis	$V_{(BAT)}$ falling	150	200	350	mV
LDO						
$V_{(LDO)}$	LDO Output Voltage	$V_{IN} = 5\text{ V}$ to 8 V , $I_{(LDO)} = 0\text{ mA}$ to 50 mA	4.7	4.9	5.1	V
$I_{(LDO)}$	Maximum LDO Output Current		60			mA
$V_{(DO)}$	Dropout Voltage	$V_{IN} = 4.5\text{V}$, $I_{(LDO)} = 50\text{ mA}$		200	350	mV

(1) Force $V_{(CHG)}$

Electrical Characteristics (continued)

 Over junction temperature range $-40^{\circ}\text{C} \leq T_J \leq 125^{\circ}\text{C}$ and recommended supply voltage (unless otherwise noted)

PARAMETER		TEST CONDITIONS	MIN	TYP	MAX	UNITS
LOGIC LEVELS ON EN						
V_{IL}	Logic low input voltage				0.4	V
V_{IH}	Logic high input voltage		1.4			V
$V_{(FLT)}$	Logic FLOAT input voltage		600	850	1100	mV
$I_{(FLT)kg}$	Maximum leakage sink or source current to keep in FLOAT				1	μA
$I_{EN(DRIVE)}$	Minimal drive current from an external device for Low or High		8			μA
BATTERY-PACK NTC MONITOR (TS)						
$V_{(COLD)}$	TS Cold Threshold	$V_{(TS)}$ Rising	23.6	25	25.8	$\%V_{LDO}$
$V_{(CUTOFF)}$	TS Cold Cutoff Threshold	$V_{(TS)}$ Falling		1		$\%V_{LDO}$
$V_{(HOT)}$	TS Hot Threshold	$V_{(TS)}$ Falling	12	12.5	13.2	$\%V_{LDO}$
$V_{(HOT)(HYS)}$	TS Hot Cutoff Threshold	$V_{(TS)}$ Rising		1		$\%V_{LDO}$
CHG OUTPUT						
V_{OL}	Output LOW voltage	$I_{(SINK)} = 1 \text{ mA}$			0.45	V
I_{IH}	Leakage current	CHG = 5 V			1	μA
THERMAL REGULATION						
$T_{J(REG)}$	Temperature Regulation Limit	T_J rising		125		$^{\circ}\text{C}$
$T_{J(OFF)}$	Thermal shutdown temperature	T_J rising		155		$^{\circ}\text{C}$
$T_{J(OFF-HYS)}$	Thermal shutdown hysteresis	T_J falling		20		$^{\circ}\text{C}$

7.6 Timing Requirements

			MIN	TYP	MAX	UNIT
INPUT						
$t_{BLK(OVP)}$	Input overvoltage blanking time			100		μs
$t_{REC(OVP)}$	Input overvoltage recovery time	Time measured from $V_{IN}: 11 \text{ V} \rightarrow 5 \text{ V}$ 1 μs fall-time to LDO = HI, $V_{(BAT)} = 3.5 \text{ V}$		100		μs
$t_{DGL(NO-IN)}$	Delay time, input power loss to charger turn-off	Time measured from $V_{IN}: 5 \text{ V} \rightarrow 2.5 \text{ V}$ 1 μs fall-time		32		ms
ISSET SHORT CIRCUIT PROTECTION						
$t_{DGL(SHORT)}$	Deglitch time transition from $I_{(SET)}$ short to I_{OUT} disable	Clear fault by cycling $V_{(BUS)}$ or EN		1.5		ms
PRE-CHARGE AND CHARGE DONE						
$t_{DGL1(LOWV)}$	Deglitch time on pre-charge to fast-charge transition			25		ms
$t_{DGL2(LOWV)}$	Deglitch time on fast-charge to pre-charge transition			25		ms
RECHARGE OR REFRESH						
$t_{DGL(RCH)}$	Deglitch time, recharge threshold detected	$V_{(BAT)}$ falling to New Charge Cycle		25		ms
BATTERY-PACK NTC MONITOR (TS)						
$t_{dgl(TS)}$	Deglitch for TS Fault	Fault detected on TS to stop charge		25		ms

7.7 Typical Characteristics

$V_{IN} = 5\text{ V}$, $V_{BAT} = 3.2\text{ V}$, $I_{(CHG)} = 280\text{ mA}$, Typical Application Circuit

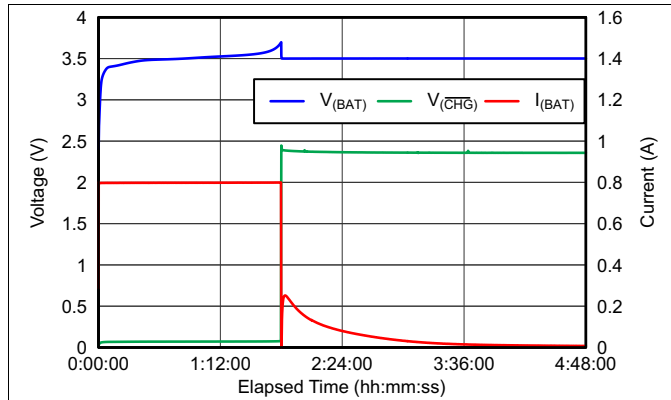

Figure 1. Voltage and Current vs Elapsed Time

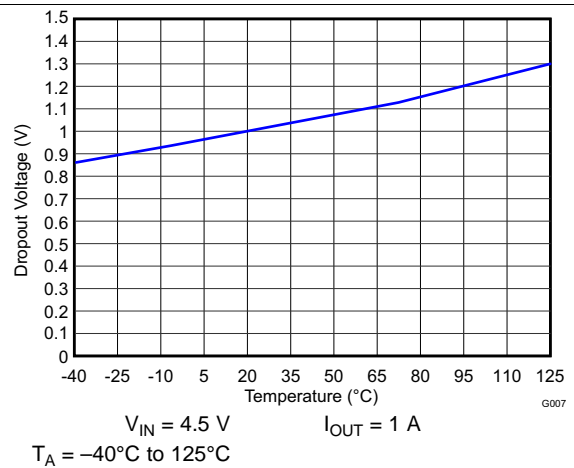

Figure 2. Dropout Voltage vs Temperature

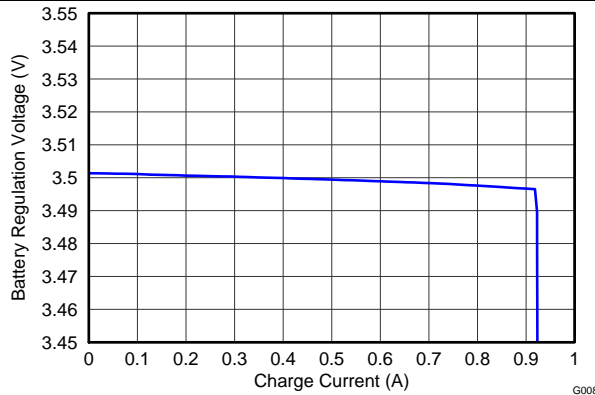

Figure 3. Battery Regulation Voltage vs Charge Current

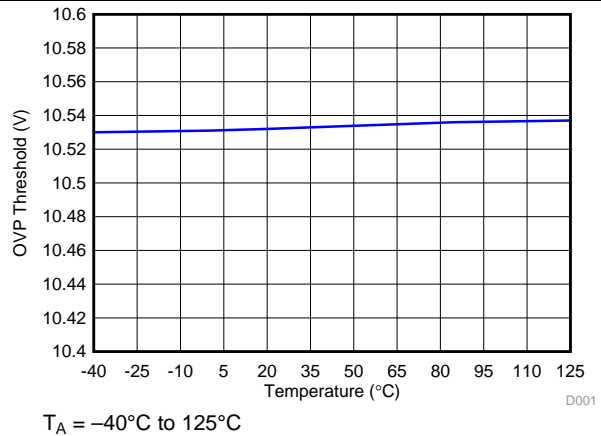

Figure 4. OVP Threshold vs Temperature

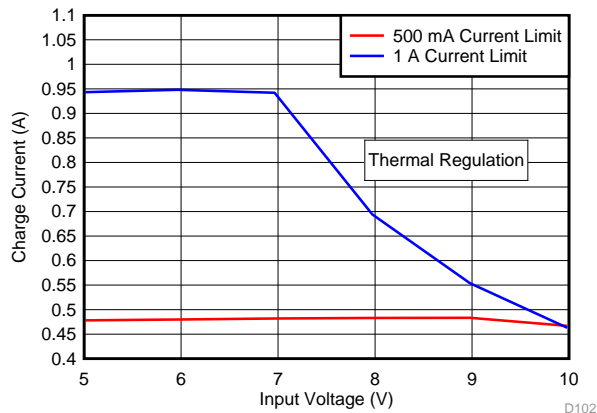

Figure 5. Charge Current vs Input Voltage

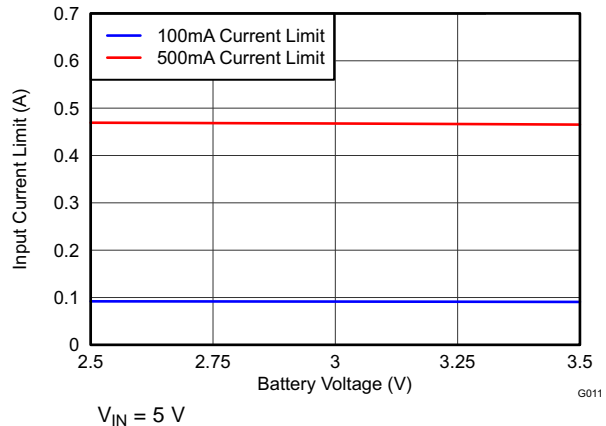
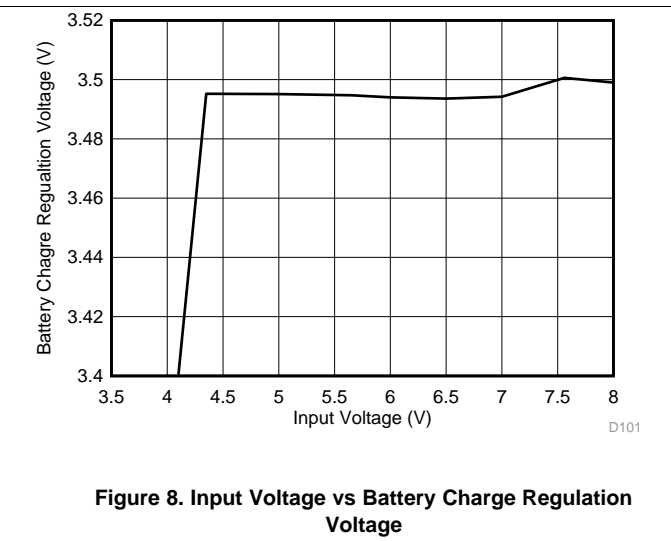
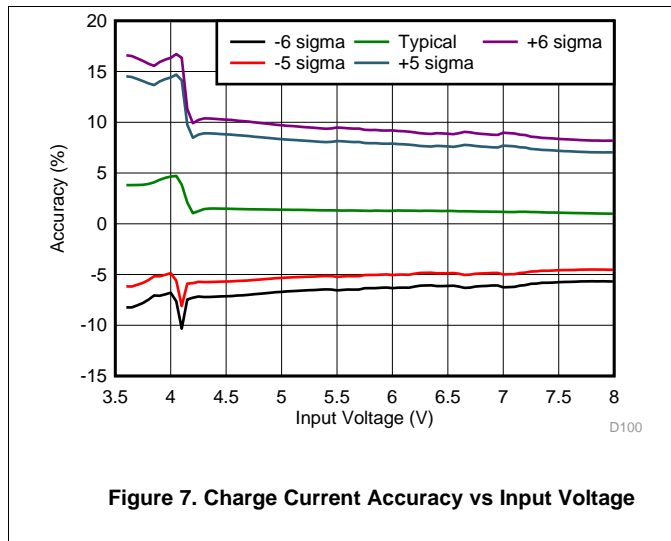

Figure 6. Input Current Limit vs Battery Voltage

7.8 Typical Characteristics

$V_{BAT} = 3.2\text{ V}$, $I_{(CHG)} = 318\text{ mA}$, Typical Application Circuit



8 Detailed Description

8.1 Overview

The bq25071-Q1 is a highly integrated, automotive qualified, linear, LiFePO₄ battery charger targeted at space-limited automotive applications. It accepts power from either a USB port or AC adapter and charges a single-cell LiFePO₄ battery with up to 1 A of charge current. The 30 V input rating with 10.5 V input overvoltage protection supports low-cost unregulated adapters.

The bq25071-Q1 has a single power output that simultaneously charges the battery and powers the system. The input current is programmable from 100 mA up to 1 A using the ISET input or configurable for USB500. There is also a 4.9 V \pm 10% 50 mA LDO is integrated into the IC for supplying low power external circuitry.

The LiFePO₄ charging algorithm removes the constant voltage mode control typically used in Li-Ion battery charge cycles which reduces charge time significantly. Instead, the battery is fast charged to the overcharge voltage and then allowed to relax to a lower float charge voltage threshold. The charger power stage and charge current sense functions are fully integrated. The charger function has high accuracy current and voltage regulation loops, and charge status display. During the charge cycle, an internal control loop monitors the IC junction temperature and reduces the charge current if an internal temperature threshold is exceeded.

8.2 Functional Block Diagram

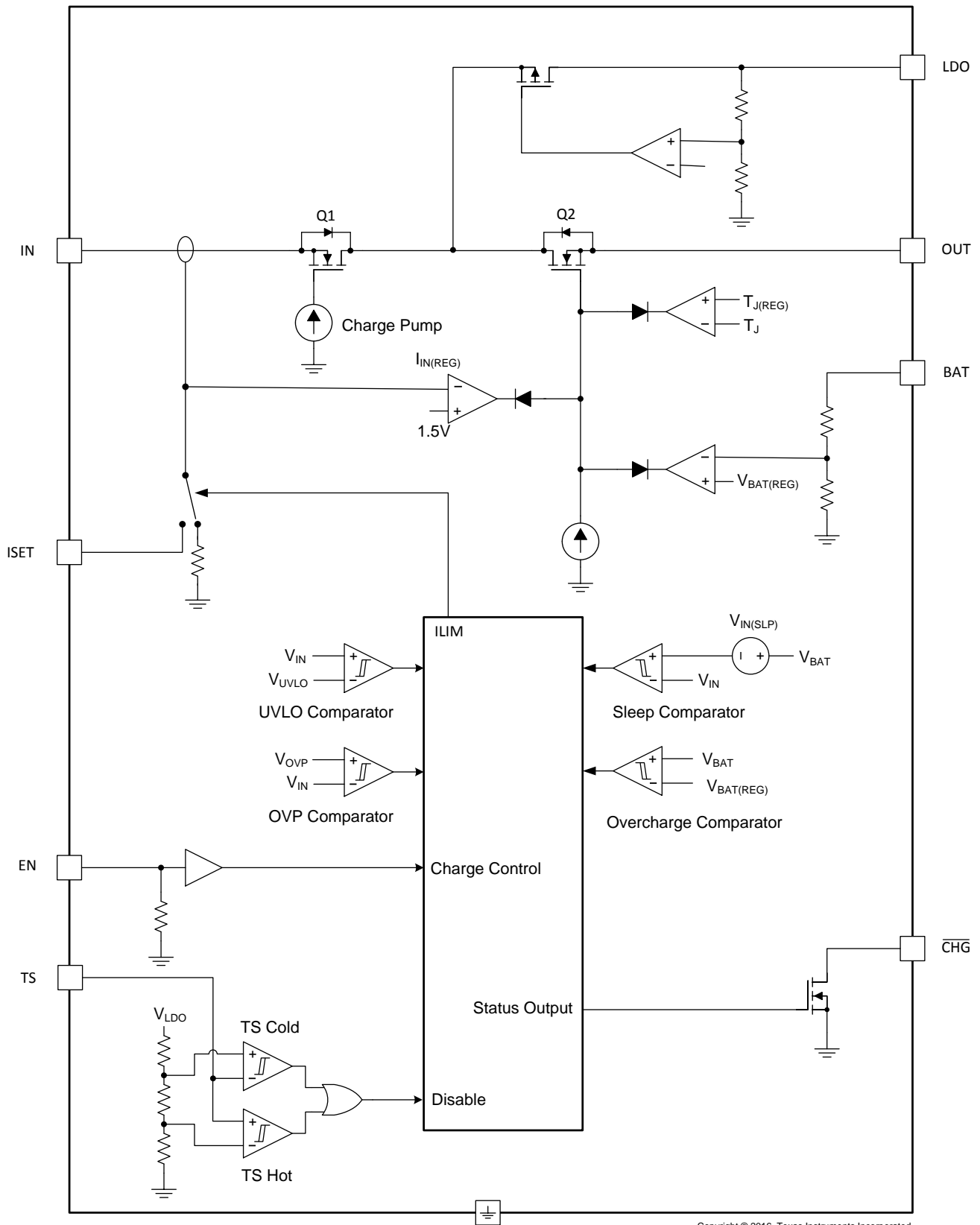

Copyright © 2016, Texas Instruments Incorporated

8.3 Feature Description

8.3.1 Input Overvoltage Protection

The bq25071-Q1 contains an input overvoltage protection circuit that disables the LDO output and charging when the input voltage rises above $V_{(OVP)}$. This prevents damage from faulty adapters. The OVP circuitry contains an 100 μ s blanking period that prevents ringing on the input from line transients from tripping the OVP circuitry falsely. If an adapter with an output greater than $V_{(OVP)}$ is plugged in, the IC completes soft-start power up and then shuts down if the voltage remains above $V_{(OVP)}$ after 100 μ s. The LDO remains off and charging remains disabled until the input voltage falls below $V_{(OVP)}$.

8.3.2 Undervoltage Lockout (UVLO)

The bq25071-Q1 remains in power down mode when the input voltage is below the undervoltage lockout threshold ($V_{(UVLO)}$). During this mode, the control input (EN) is ignored. The LDO, the charge FET connected between IN and OUT are off and the status output (CHG) is high impedance. Once the input voltage rises above $V_{(UVLO)}$, the internal circuitry is turned on and the normal operating procedures are followed.

8.3.3 External NTC Monitoring (TS)

The bq25071-Q1 features a flexible, voltage based external battery pack temperature monitoring input. The TS input connects to the NTC thermistor in the battery pack to monitor battery temperature and prevent dangerous over-temperature conditions. During charging, the voltage at TS is continuously monitored. If the voltage at the TS pin is outside of the operating range ($V_{(HOT)}$ to $V_{(COLD)}$) for longer than the built in 25 ms deglitch time, charging is suspended. When the voltage measured at TS returns to within the operation window, charging resumes. When a battery pack temperature fault occurs charging is suspended, but the CHG output remains low and continues to indicate charging.

The temperature thresholds are programmed using a resistor divider from LDO to GND with the NTC thermistor connected to the center tap from TS to GND. See Figure 9 for the circuit example. The value of R1 and R2 are calculated using the following equations:

$$R1 = \frac{-R2 \times RHOT \times (0.125 - 1)}{0.125 \times (R2 + RHOT)} \quad (1)$$

$$R2 = \frac{-RHOT \times RCOLD \times (0.125 - 0.250)}{RHOT \times 0.250 \times (0.125 - 1) + RCOLD \times 0.125 \times (1 - 0.250)} \quad (2)$$

RHOT is the expected thermistor resistance at the programmed hot threshold; RCOLD is the expected thermistor resistance at the programmed cold threshold.

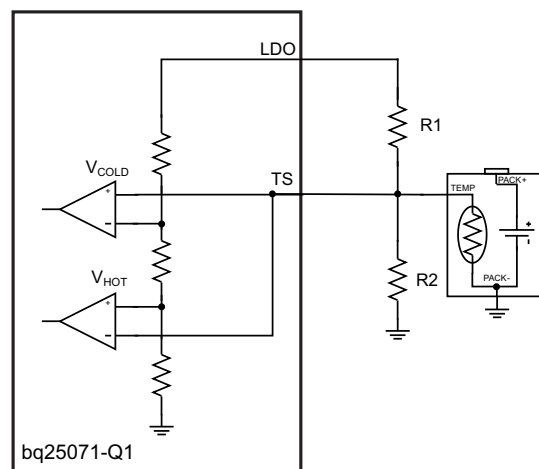

For applications that do not require the TS monitoring function, set $R1 = 490 \text{ k}\Omega$ and $R2 = 100 \text{ k}\Omega$ to set the TS voltage at a valid level and maintain charging.

Figure 9. NTC Monitoring Function

Feature Description (continued)

8.3.4 50-mA LDO (LDO)

The LDO output of the bq25071-Q1 is a low dropout linear regulator (LDO) that supplies up to 50 mA while regulating to $V_{(LDO)}$. The LDO is active whenever the input voltage is above $V_{(UVLO)}$ and below $V_{(OVP)}$. It is not affected by the EN input. The LDO output is used to power and protect circuitry such as USB transceivers from transients on the input supply.

8.3.5 Charge Status Indicator ($\overline{\text{CHG}}$)

The bq25071-Q1 contains an open drain $\overline{\text{CHG}}$ output that indicates charging state and faults. When charging a battery in precharge or fastcharge mode, the $\overline{\text{CHG}}$ output is pulled to GND. Once the BAT output reaches the overcharge voltage threshold, $\overline{\text{CHG}}$ goes high impedance to signal the battery is fully charged. When the battery voltage drops below the recharge voltage threshold the $\overline{\text{CHG}}$ output is pulled low to signal the host of a new charge cycle. Connect $\overline{\text{CHG}}$ to the required logic level voltage through a 1 k Ω to 100 k Ω resistor to use the signal with a microprocessor. $I_{(\overline{\text{CHG}})}$ must be below 5 mA.

The IC monitors the CHG pin when no input is connected to verify if the system circuitry is active. If the voltage at CHG is logic being drive low when no input is connected, the TS circuit is turned off for a low quiescent current state. Once the voltage at CHG increases above logic high, the TS circuit is turned on.

8.3.6 Input Current Limit Control (EN)

The bq25071-Q1 contains a 3-state that controls the input current limit. Drive EN low to program the input current limit to the user defined value programmed using ISET. Drive EN high to place the bq25071-Q1 in USB suspend mode. In USB suspend mode, the input current into bq25071-Q1 is reduced. Leaving EN unconnected or connected to a high impedance source programs the USB500 input current limit.

Table 1. EN Input Definition

EN	MODE
Low	ISET
Hi-Z	USB500
Hi	USB Suspend

8.4 Device Functional Modes

8.4.1 Charging Operation

The bq25071-Q1 uses a charge algorithm that is unique to LiFePO₄ chemistry cells. The current taper typically seen as part of the constant voltage mode control usually present in Li-Ion battery charge cycles is replaced with a floating regulation voltage with minimal charging current. This dramatically decreases the charge time. When the bq25071-Q1 is enabled by EN, the battery voltage is monitored to verify which stage of charging must be used. When $V_{(BAT)} < V_{(LOWV)}$, the bq25071-Q1 charges in precharge mode; when $V_{(BAT)} > V_{(LOWV)}$, the normal charge cycle is used.

8.4.1.1 Charger Operation with Minimum System Voltage Mode Enabled

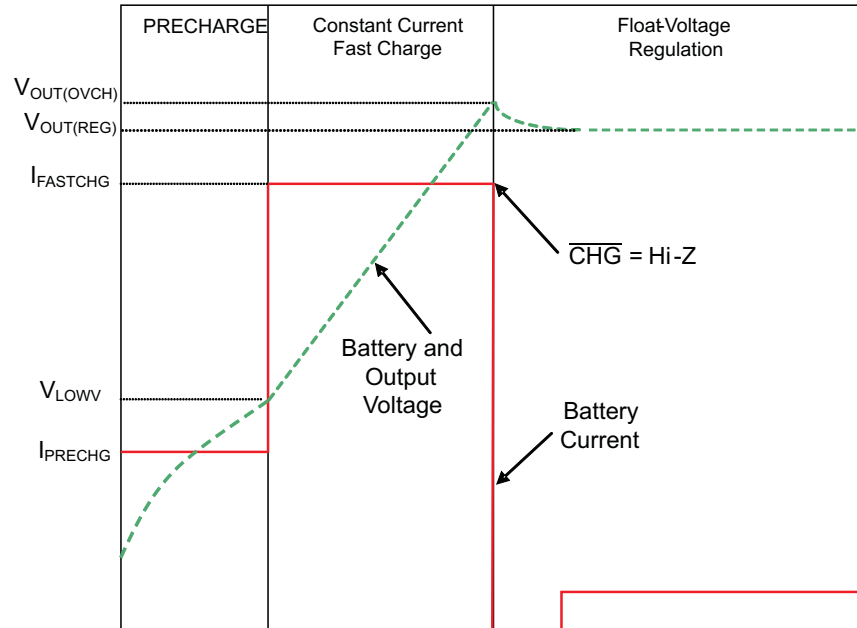

Figure 10. Typical Charging Cycle with Minimum System Voltage Enabled

8.4.1.2 Precharge Mode ($V_{(BAT)} \leq V_{(LOWV)}$)

The bq25071-Q1 enters precharge mode when $V_{BAT} \leq V_{(LOWV)}$. Upon entering precharge mode, the battery is charged with a 47.5 mA current and \overline{CHG} goes low.

8.4.1.3 Fast Charge Mode

Once $V_{(BAT)} > V_{(LOWV)}$, the bq25071-Q1 enters constant current (CC) mode where charge current is regulated using the internal MOSFETs between IN and OUT. The total current is shared between the output load and the battery. Once the battery voltage charges up to $V_{BAT(OVCH)}$, the \overline{CHG} output goes high indicating the charge cycle is complete and the bq25071-Q1 switches the battery regulation voltage to $V_{BAT(REG)}$. The battery voltage is allowed to relax down to $V_{BAT(REG)}$. The charger remains enabled and regulates the output to $V_{BAT(REG)}$. If at any time the battery falls below $V_{(RCH)}$, the charge cycle restarts.

Device Functional Modes (continued)

8.4.2 Programmable Input Current Limit (ISET)

When the charger is enabled, and the user programmable current limit is selected by the EN input, internal circuits generate a current proportional to the input current at the ISET input. The current out of ISET is 1/1000 ($\pm 10\%$) of the charge current. This current, when applied to the external charge current programming resistor, R1 ([Figure 11](#)), generates an analog voltage that is regulated to program the fast charge current. Connect a resistor from ISET to GND to program the input current limit using the following equation:

$$I_{(IN_LIM)} = \frac{K_{(ISET)}}{R_{(ISET)}} = \frac{1000A \times \Omega}{R_{(ISET)}} \quad (3)$$

$I_{(IN_LIM)}$ is programmable from 100 mA to 1 A. The voltage at ISET can be monitored by an external host to calculate the charging current to the battery. The input current is related to the ISET voltage using the following equation:

$$I_{IN} = V_{(ISET)} \times \frac{1000}{R_{(ISET)}} \quad (4)$$

Monitoring the ISET voltage allows for the host to calculate the actual charging current and therefore perform more accurate termination. The input current to the system must be monitored and subtracted from the current into the bq25071-Q1 which is show by $V_{(ISET)}$.

8.4.3 Sleep Mode

If the IN pin voltage is between $V_{(UVLO)}$ and $V_{(BAT)} + V_{(IN_SLP)}$, the charge current is disabled, the safety timer counting stops (not reset) and the CHG pin is high impedance. As the input voltage rises and the charger exits sleep mode, the safety timer continues to count, charge is enabled and the CHG pin returns to its previous state.

8.4.4 Thermal Regulation and Thermal Shutdown

The bq25071-Q1 contains a thermal regulation loop that monitors the die temperature continuously. If the temperature exceeds $T_{J(REG)}$, the device automatically reduces the charging current to prevent the die temperature from increasing further. In some cases, the die temperature continues to rise despite the operation of the thermal loop, particularly under high V_{IN} conditions. If the die temperature increases to $T_{J(OFF)}$, the IC is turned off. Once the device die temperature cools by $T_{J(OFF-HYS)}$, the device turns on and returns to thermal regulation. Continuous overtemperature conditions result in the pulsing of the load current. If the junction temperature of the device exceeds $T_{J(OFF)}$, the charge FET is turned off. The FET is turned back on when the junction temperature falls below $T_{J(OFF)} - T_{J(OFF-HYS)}$.

Note that these features monitor the die temperature of the bq25071-Q1. This is not synonymous with ambient temperature. Self heating exists due to the power dissipated in the IC because of the linear nature of the battery charging algorithm.

9 Application and Implementation

NOTE

Information in the following applications sections is not part of the TI component specification, and TI does not warrant its accuracy or completeness. TI's customers are responsible for determining suitability of components for their purposes. Customers should validate and test their design implementation to confirm system functionality.

9.1 Application Information

The typical application circuit uses a single output which charges the battery and powers the system. Additionally a 50-mA LDO can supply a low power external circuit.

The bq25071EVM-658 evaluation module (EVM) is a complete charger module for evaluating the bq25071-Q1. Refer to [SLUUB49](#).

9.2 Typical Application

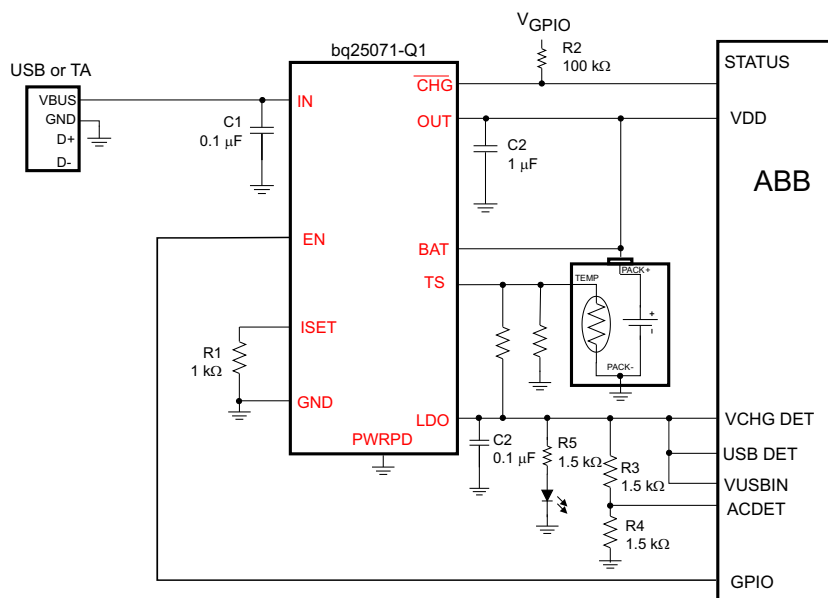

Copyright © 2016, Texas Instruments Incorporated

Figure 11. bq25071-Q1 Typical Application Circuit

9.2.1 Design Requirements

Table 2. Design Parameters

PARAMETER	EXAMPLE VALUE
Input supply range	5 V ±5%
Output voltage range	3.5 V
Output current rating	1000 mA

9.2.2 Detailed Design Procedure

9.2.2.1 Selection of Input and Output Capacitors

In most applications, all that is needed is a high-frequency decoupling capacitor on the input power pin. For normal charging applications, a 0.1 μF ceramic capacitor, placed in close proximity to the IN pin and GND pad works best. In some applications, depending on the power supply characteristics and cable length, it may be necessary to increase the input filter capacitor to avoid exceeding the OVP voltage threshold during adapter hot plug events where the ringing exceeds the deglitch time.

The charger in the bq25071-Q1 requires a capacitor from OUT to GND for loop stability. Connect a 1 μF ceramic capacitor from OUT to GND close to the pins for best results. More output capacitance may be required to minimize the output drop during large load transients.

The LDO also requires an output capacitor for loop stability. Connect a 0.1 μF ceramic capacitor from LDO to GND close to the pins. For improved transient response, this capacitor may be increased.

9.2.2.2 Thermal Considerations

The bq25071-Q1 is packaged in a thermally enhanced QFN package. The package includes a thermal pad to provide an effective thermal contact between the IC and the printed circuit board (PCB). Full PCB design guidelines for this package are provided in the application note entitled: *QFN/SON PCB Attachment Application Note (SLUA271)*.

The most common measure of package thermal performance is thermal impedance (θ_{JA}) measured (or modeled) from the chip junction to the air surrounding the package surface (ambient). The mathematical expression for θ_{JA} is:

Where:

$$\theta_{JA} = \frac{T_J - T_A}{P_D} \quad (5)$$

T_J = chip junction temperature

T_A = ambient temperature

P_D = device power dissipation

Factors that can greatly influence the measurement and calculation of θ_{JA} include:

- Whether or not the device is board mounted
- Trace size, composition, thickness, and geometry
- Orientation of the device (horizontal or vertical)
- Volume of the ambient air surrounding the device under test and airflow
- Whether other surfaces are in close proximity to the device being tested

The device power dissipation, P_D , is a function of the charge rate and the voltage drop across the internal PowerFET. It can be calculated from the following equation when a battery pack is being charged:

$$P_D = (V_{IN} - V_{OUT}) \times I_{OUT}$$

Due to the charge profile of LiFePO_4 batteries the maximum power dissipation is typically seen at the beginning of the charge cycle when the battery voltage is at its lowest. See the charging profile, [Figure 10](#). If the board thermal design is not adequate the programmed fast charge rate current may not be achieved under maximum input voltage and minimum battery voltage, as the thermal loop can be active, effectively reducing the charge current to avoid excessive IC junction temperature.

9.2.3 Application Curves

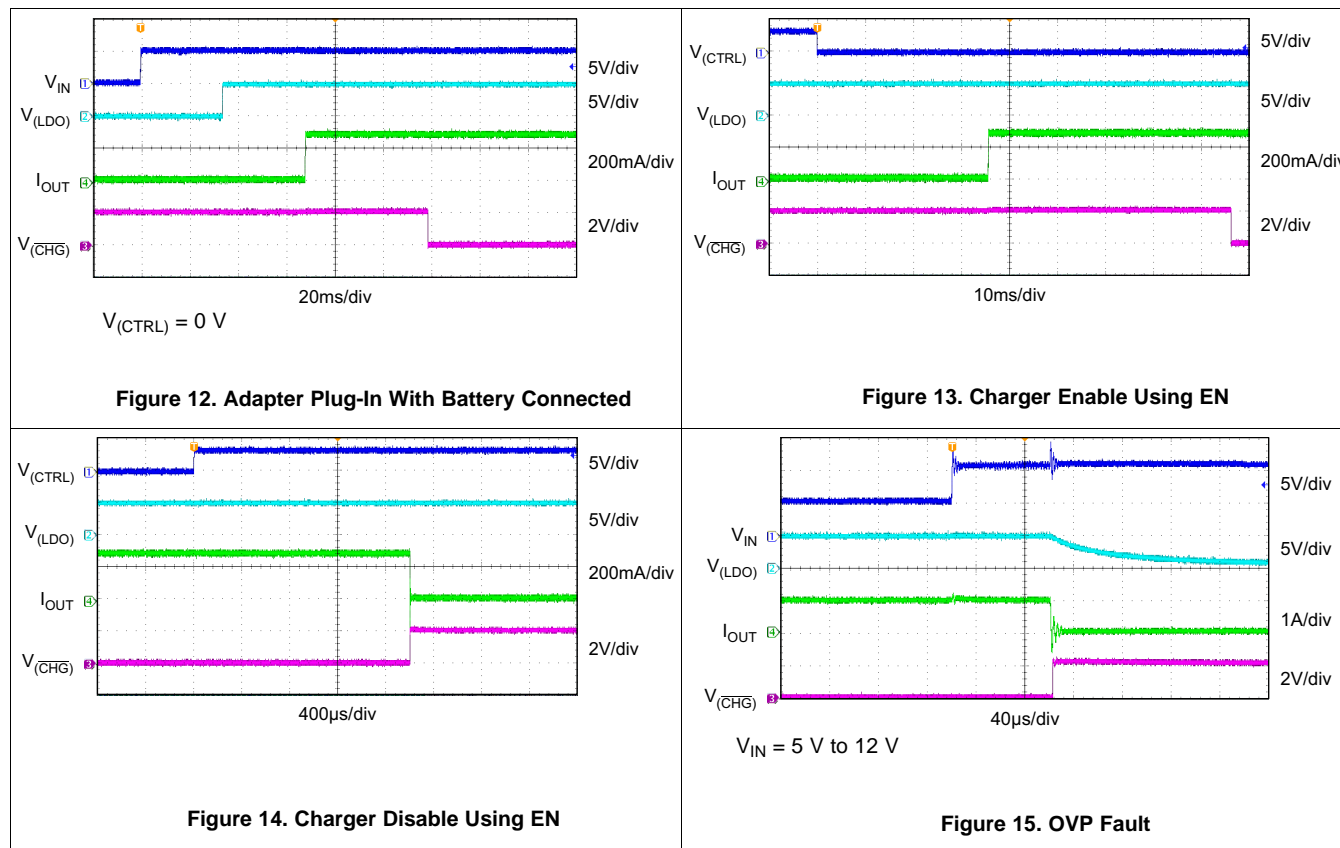

9.3 System Examples

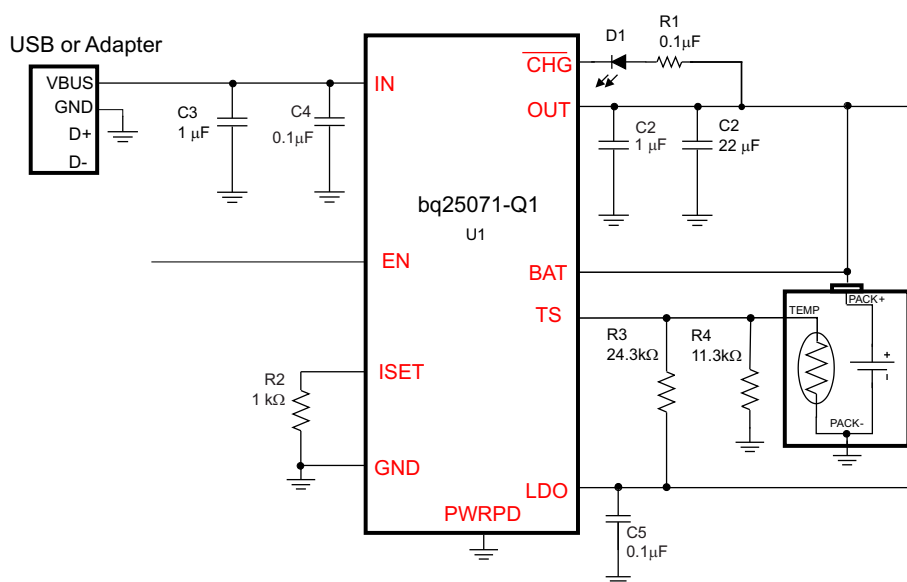

Copyright © 2016, Texas Instruments Incorporated

Figure 16. Schematic

10 Power Supply Recommendations

In a typical application, the system is powered by a USB port or USB wall adapter.

The wide input voltage range supports low cost and unregulated adapters.

The minimum input voltage - where the charging process starts with a reduced charging current - could be 3.75 V when the battery voltage is below 3.5 V. The minimum input voltage can be up to 3.875 V when the battery is close to be fully charged (Please refer to the Sleep Mode) or there is no battery presented. The maximum recommended operating input voltage is up to 8 V; the overvoltage protection kicks in at 10.5 V and the maximum input voltage rating is 30 V Input Rating.

11 Layout

11.1 Layout Guidelines

It is important to pay special attention to the PCB layout. The following provides some guidelines:

- To obtain optimal performance, the decoupling capacitor from IN to GND (thermal pad) and the output filter capacitors from OUT to GND (thermal pad) should be placed as close as possible to the bq25071-Q1, with short trace runs to both IN, OUT and GND (thermal pad).
- All low-current GND connections should be kept separate from the high-current charge or discharge paths from the battery. Use a single-point ground technique incorporating both the small signal ground path and the power ground path.
- The high current charge paths into IN pin and from the OUT pin must be sized appropriately for the maximum charge current in order to avoid voltage drops in these traces.
- The bq25071-Q1 is packaged in a thermally enhanced SON package. The package includes a thermal pad to provide an effective thermal contact between the IC and the printed circuit board (PCB); this thermal pad is also the main ground connection for the device. Connect the thermal pad to the PCB ground connection. Full PCB design guidelines for this package are provided in the application note entitled: *QFN/SON PCB Attachment Application Note (SLUA271)*.

11.2 Layout Example

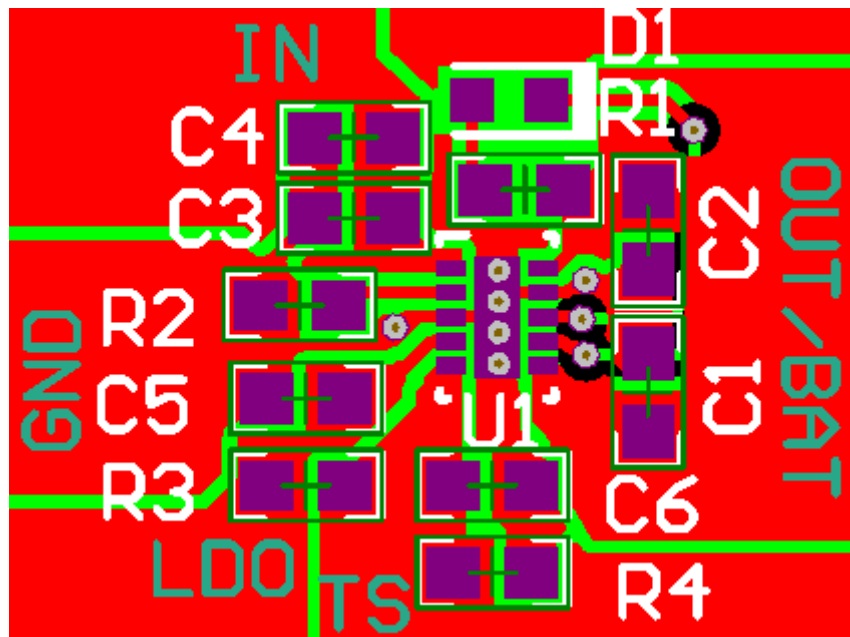

The bottom plane is a ground plane that is connected to the top through vias.

12 器件和文档支持

12.1 社区资源

The following links connect to TI community resources. Linked contents are provided "AS IS" by the respective contributors. They do not constitute TI specifications and do not necessarily reflect TI's views; see TI's [Terms of Use](#).

TI E2E™ Online Community *TI's Engineer-to-Engineer (E2E) Community*. Created to foster collaboration among engineers. At e2e.ti.com, you can ask questions, share knowledge, explore ideas and help solve problems with fellow engineers.

Design Support *TI's Design Support* Quickly find helpful E2E forums along with design support tools and contact information for technical support.

12.2 商标

E2E is a trademark of Texas Instruments. All other trademarks are the property of their respective owners.

12.3 静电放电警告



这些装置包含有限的内置 ESD 保护。存储或装卸时，应将导线一起截短或将装置放置于导电泡棉中，以防止 MOS 门极遭受静电损伤。

12.4 Glossary

[SLYZ022](#) — *TI Glossary*.

This glossary lists and explains terms, acronyms, and definitions.

13 机械、封装和可订购信息

以下页中包括机械、封装和可订购信息。这些信息是针对指定器件可提供的最新数据。这些数据会在无通知且不对本文档进行修订的情况下发生改变。欲获得该数据表的浏览器版本，请查阅左侧的导航栏。

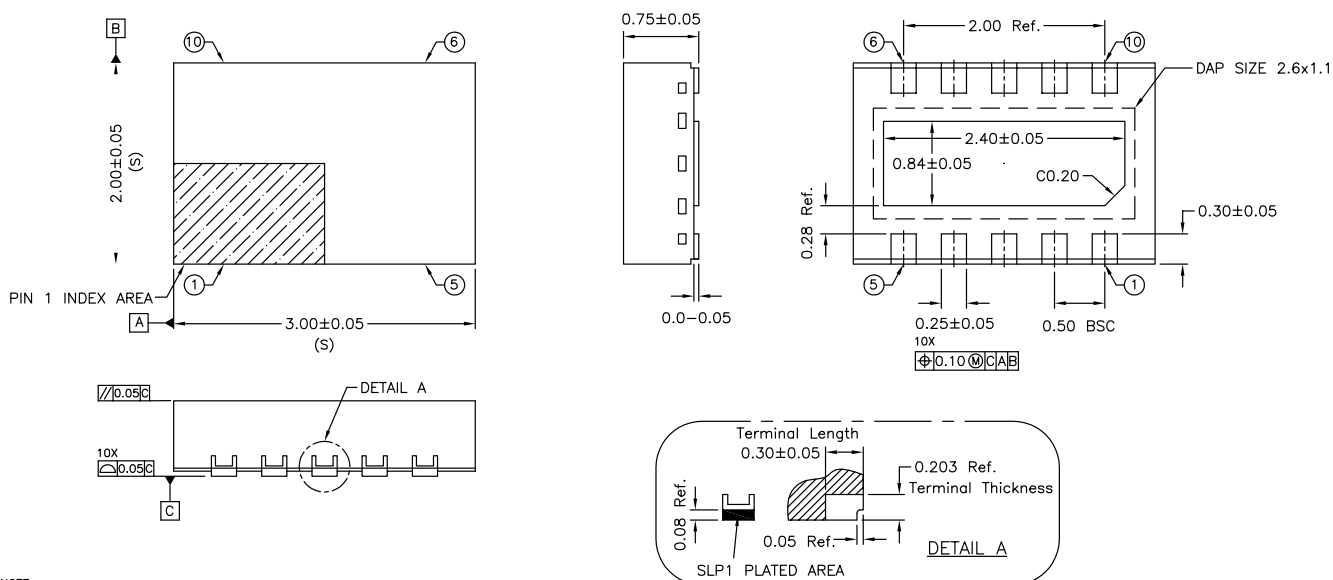

NOTE :

1. ALL DIMENSION ARE IN mm. ANGLES IN DEGREES.
2. COPLANARITY APPLIES TO THE EXPOSED PAD AS WELL AS THE TERMINALS. COPLANARITY SHALL NOT EXCEED 0.05 mm.
3. WARPAGE SHALL NOT EXCEED 0.05 mm.
4. PACKAGE LENGTH / PACKAGE WIDTH ARE CONSIDERED AS SPECIAL CHARACTERISTIC.(S)
5. REFER JEDEC MO-229.

重要声明

德州仪器(TI)及其下属子公司有权根据 JESD46 最新标准,对所提供的产品和服务进行更正、修改、增强、改进或其它更改,并有权根据 JESD48 最新标准中止提供任何产品和服务。客户在下订单前应获取最新的相关信息,并验证这些信息是否完整且是最新的。所有产品的销售都遵循在订单确认时所提供的TI 销售条款与条件。

TI 保证其所销售的组件的性能符合产品销售时 TI 半导体产品销售条件与条款的适用规范。仅在 TI 保证的范围内,且 TI 认为有必要时才会使用测试或其它质量控制技术。除非适用法律做出了硬性规定,否则没有必要对每种组件的所有参数进行测试。

TI 对应用帮助或客户产品设计不承担任何义务。客户应对其使用 TI 组件的产品和应用自行负责。为尽量减小与客户产品和应用相关的风险,客户应提供充分的设计与操作安全措施。

TI 不对任何 TI 专利权、版权、屏蔽作品权或其它与使用了 TI 组件或服务的组合设备、机器或流程相关的 TI 知识产权中授予的直接或隐含权限作出任何保证或解释。TI 所发布的与第三方产品或服务有关的信息,不能构成从 TI 获得使用这些产品或服务的许可、授权、或认可。使用此类信息可能需要获得第三方的专利权或其它知识产权方面的许可,或是 TI 的专利权或其它知识产权方面的许可。

对于 TI 的产品手册或数据表中 TI 信息的重要部分,仅在没有对内容进行任何篡改且带有相关授权、条件、限制和声明的情况下才允许进行复制。TI 对此类篡改过的文件不承担任何责任或义务。复制第三方的信息可能需要服从额外的限制条件。

在转售 TI 组件或服务时,如果对该组件或服务参数的陈述与 TI 标明的参数相比存在差异或虚假成分,则会失去相关 TI 组件或服务的所有明示或暗示授权,且这是不正当的、欺诈性商业行为。TI 对任何此类虚假陈述均不承担任何责任或义务。

客户认可并同意,尽管任何应用相关信息或支持仍可能由 TI 提供,但他们将独立负责满足与其产品及其在应用中使用的 TI 产品相关的所有法律、法规和安全相关要求。客户声明并同意,他们具备制定与实施安全措施所需的全部专业技术和知识,可预见故障的危险后果、监测故障及其后果、降低有可能造成人身伤害的故障的发生机率并采取适当的补救措施。客户将全额赔偿因在此类安全关键应用中使用任何 TI 组件而对 TI 及其代理造成的任何损失。

在某些场合中,为了推进安全相关应用有可能对 TI 组件进行特别的促销。TI 的目标是利用此类组件帮助客户设计和创立其特有的可满足适用的功能安全性标准和要求的终端产品解决方案。尽管如此,此类组件仍然服从这些条款。

TI 组件未获得用于 FDA Class III (或类似的生命攸关医疗设备)的授权许可,除非各方授权官员已经达成了专门管控此类使用的特别协议。

只有那些 TI 特别注明属于军用等级或“增强型塑料”的 TI 组件才是设计或专门用于军事/航空应用或环境的。购买者认可并同意,对并非指定面向军事或航空航天用途的 TI 组件进行军事或航空航天方面的应用,其风险由客户单独承担,并且由客户独立负责满足与此类使用相关的所有法律和法规要求。

TI 已明确指定符合 ISO/TS16949 要求的产品,这些产品主要用于汽车。在任何情况下,因使用非指定产品而无法达到 ISO/TS16949 要求, TI 不承担任何责任。

	产品		应用
数字音频	www.ti.com.cn/audio	通信与电信	www.ti.com.cn/telecom
放大器和线性器件	www.ti.com.cn/amplifiers	计算机及周边	www.ti.com.cn/computer
数据转换器	www.ti.com.cn/dataconverters	消费电子	www.ti.com.cn/consumer-apps
DLP® 产品	www.dlp.com	能源	www.ti.com.cn/energy
DSP - 数字信号处理器	www.ti.com.cn/dsp	工业应用	www.ti.com.cn/industrial
时钟和计时器	www.ti.com.cn/clockandtimers	医疗电子	www.ti.com.cn/medical
接口	www.ti.com.cn/interface	安防应用	www.ti.com.cn/security
逻辑	www.ti.com.cn/logic	汽车电子	www.ti.com.cn/automotive
电源管理	www.ti.com.cn/power	视频和影像	www.ti.com.cn/video
微控制器 (MCU)	www.ti.com.cn/microcontrollers		
RFID 系统	www.ti.com.cn/rfidsys		
OMAP应用处理器	www.ti.com/omap		
无线连通性	www.ti.com.cn/wirelessconnectivity	德州仪器在线技术支持社区	www.deyisupport.com

邮寄地址: 上海市浦东新区世纪大道1568号, 中建大厦32楼邮政编码: 200122
Copyright © 2016, 德州仪器半导体技术(上海)有限公司

PACKAGING INFORMATION

Orderable Device	Status (1)	Package Type	Package Drawing	Pins	Package Qty	Eco Plan (2)	Lead finish/ Ball material (6)	MSL Peak Temp (3)	Op Temp (°C)	Device Marking (4/5)	Samples
BQ25071QWDQCRQ1	ACTIVE	WSON	DQC	10	3000	RoHS & Green	SN	Level-2-260C-1 YEAR	-40 to 125	11V	Samples
BQ25071QWDQCTQ1	ACTIVE	WSON	DQC	10	250	RoHS & Green	SN	Level-2-260C-1 YEAR	-40 to 125	11V	Samples

(1) The marketing status values are defined as follows:

ACTIVE: Product device recommended for new designs.

LIFEBUY: TI has announced that the device will be discontinued, and a lifetime-buy period is in effect.

NRND: Not recommended for new designs. Device is in production to support existing customers, but TI does not recommend using this part in a new design.

PREVIEW: Device has been announced but is not in production. Samples may or may not be available.

OBSOLETE: TI has discontinued the production of the device.

(2) **RoHS:** TI defines "RoHS" to mean semiconductor products that are compliant with the current EU RoHS requirements for all 10 RoHS substances, including the requirement that RoHS substance do not exceed 0.1% by weight in homogeneous materials. Where designed to be soldered at high temperatures, "RoHS" products are suitable for use in specified lead-free processes. TI may reference these types of products as "Pb-Free".

RoHS Exempt: TI defines "RoHS Exempt" to mean products that contain lead but are compliant with EU RoHS pursuant to a specific EU RoHS exemption.

Green: TI defines "Green" to mean the content of Chlorine (Cl) and Bromine (Br) based flame retardants meet JS709B low halogen requirements of <=1000ppm threshold. Antimony trioxide based flame retardants must also meet the <=1000ppm threshold requirement.

(3) MSL, Peak Temp. - The Moisture Sensitivity Level rating according to the JEDEC industry standard classifications, and peak solder temperature.

(4) There may be additional marking, which relates to the logo, the lot trace code information, or the environmental category on the device.

(5) Multiple Device Markings will be inside parentheses. Only one Device Marking contained in parentheses and separated by a "~" will appear on a device. If a line is indented then it is a continuation of the previous line and the two combined represent the entire Device Marking for that device.

(6) Lead finish/Ball material - Orderable Devices may have multiple material finish options. Finish options are separated by a vertical ruled line. Lead finish/Ball material values may wrap to two lines if the finish value exceeds the maximum column width.

Important Information and Disclaimer:The information provided on this page represents TI's knowledge and belief as of the date that it is provided. TI bases its knowledge and belief on information provided by third parties, and makes no representation or warranty as to the accuracy of such information. Efforts are underway to better integrate information from third parties. TI has taken and continues to take reasonable steps to provide representative and accurate information but may not have conducted destructive testing or chemical analysis on incoming materials and chemicals. TI and TI suppliers consider certain information to be proprietary, and thus CAS numbers and other limited information may not be available for release.

In no event shall TI's liability arising out of such information exceed the total purchase price of the TI part(s) at issue in this document sold by TI to Customer on an annual basis.

重要声明和免责声明

TI 均以“原样”提供技术性及其可靠性数据（包括数据表）、设计资源（包括参考设计）、应用或其他设计建议、网络工具、安全信息和其他资源，不保证其中不含任何瑕疵，且不做任何明示或暗示的担保，包括但不限于对适销性、适合某特定用途或不侵犯任何第三方知识产权的暗示担保。

所述资源可供专业开发人员应用TI 产品进行设计使用。您将对以下行为独自承担全部责任：(1) 针对您的应用选择合适的TI 产品；(2) 设计、验证并测试您的应用；(3) 确保您的应用满足相应标准以及任何其他安全、安保或其他要求。所述资源如有变更，恕不另行通知。TI 对您使用所述资源的授权仅限于开发资源所涉及TI 产品的相关应用。除此之外不得复制或展示所述资源，也不提供其它TI 或任何第三方的知识产权授权许可。如因使用所述资源而产生任何索赔、赔偿、成本、损失及债务等，TI 对此概不负责，并且您须赔偿由此对TI 及其代表造成的损害。

TI 所提供产品均受TI 的销售条款 (<http://www.ti.com.cn/zh-cn/legal/termsofsale.html>) 以及ti.com.cn 上或随附TI 产品提供的其他可适用条款的约束。TI 提供所述资源并不扩展或以其他方式更改TI 针对TI 产品所发布的可适用的担保范围或担保免责声明。

邮寄地址：上海市浦东新区世纪大道 1568 号中建大厦 32 楼，邮政编码：200122

Copyright © 2020 德州仪器半导体技术（上海）有限公司