

FDC2112-Q1、FDC2114-Q1、FDC2212-Q1、FDC2214-Q1 适用于电容式传感的多通道 12 位或 28 位电容数字转换器 (FDC)

1 特性

- 适用于汽车电子 应用
- 具有符合 AEC-Q100 标准的下列结果：
 - 器件温度 1 级：环境运行温度范围为 -40°C 至 +125°C
 - 器件人体放电模式 (HBM) 静电放电 (ESD) 分类等级 2
 - 器件组件充电模式 (CDM) ESD 分类等级 C5
- 抗电磁干扰 (EMI) 架构
- 最高输出速率（每条激活通道）：
 - 13.3KSPS (FDC2112-Q1 和 FDC2114-Q1)
 - 4.08KSPS (FDC2212-Q1 和 FDC2214-Q1)
- 最大输入电容：250nF (10kHz 频率，1mH 电感时)
- 传感器激励频率：10kHz 至 10MHz
- 通道数：2 或 4
- 分辨率：高达 28 位
- 均方根 (RMS) 噪声：0.3fF (100SPS 且 $f_{\text{传感器}} = 5\text{MHz}$ 时)
- 电源电压：2.7V 至 3.6V
- 功耗：2.1mA (有源)
- 低功耗休眠模式：35μA
- 关断电流：200nA
- 接口：I²C
- 温度范围：-40°C 至 +125°C

2 应用

- 抗 EMI 型接近度传感器
- 抗 EMI 型手势识别
- 抗 EMI 型外来物体检测
- 抗 EMI 型雨/雾/冰/雪传感器
- 汽车车门/脚踢传感器

3 说明

电容式传感是一种低功耗、低成本且高分辨率的非接触式感测技术，适用于 接近度检测、手势识别等各类应用。电容式传感系统中的传感器可以采用任意金属或导体，因此可实现高度灵活的低成本系统设计。

电容式传感应用灵敏度的主要限制因素 在于 传感器的噪声敏感性。FDC2x1x-Q1 采用创新型抗 EMI 架构，即使在高噪声环境中也能使性能保持不变。

FDC2x1x-Q1 是面向电容式传感解决方案的抗噪声和 EMI、高分辨率、高速、多通道电容-数字转换器系列。该系列器件采用基于窄带的创新型架构，可对噪声和干扰进行高度抑制，同时在高速条件下提供高分辨率。该系列器件支持宽激励频率范围，可为系统设计带来灵活性。

器件信息⁽¹⁾

器件型号	封装	封装尺寸 (标称值)
FDC2112-Q1	WSON (12)	4.00mm x 4.00mm
FDC2114-Q1	WQFN (16)	4.00mm x 4.00mm
FDC2212-Q1	WSON (12)	4.00mm x 4.00mm
FDC2214-Q1	WQFN (16)	4.00mm x 4.00mm

(1) 要了解所有可用封装，请见数据表末尾的可订购产品附录。

简化电路原理图

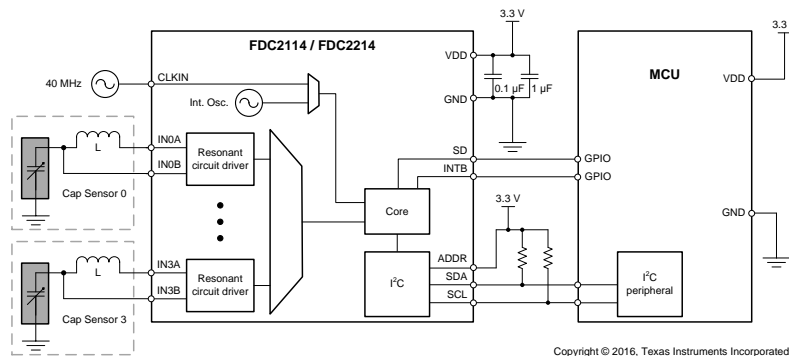

目录

1	特性	1	7.5	Programming.....	21
2	应用	1	7.6	Register Maps	22
3	说明	1	8	Application and Implementation	39
4	修订历史记录	2	8.1	Application Information.....	39
5	Pin Configuration and Functions	3	8.2	Typical Application	41
6	Specifications.....	4	8.3	Do's and Don'ts.....	45
6.1	Absolute Maximum Ratings	4	9	Power Supply Recommendations	45
6.2	ESD Ratings.....	4	10	Layout.....	45
6.3	Recommended Operating Conditions.....	4	10.1	Layout Guidelines	45
6.4	Thermal Information	4	10.2	Layout Examples.....	45
6.5	Electrical Characteristics.....	5	11	器件和文档支持	50
6.6	Timing Requirements	6	11.1	器件支持	50
6.7	Switching Characteristics - I2C	7	11.2	文档支持	50
6.8	Typical Characteristics	8	11.3	社区资源	50
7	Detailed Description	10	11.4	相关链接	50
7.1	Overview	10	11.5	商标	50
7.2	Functional Block Diagrams	10	11.6	静电放电警告	50
7.3	Feature Description.....	11	11.7	Glossary	50
7.4	Device Functional Modes.....	20	12	机械、封装和可订购信息	51

4 修订历史记录

日期	修订版本	注释
2016 年 5 月	*	最初发布。

5 Pin Configuration and Functions

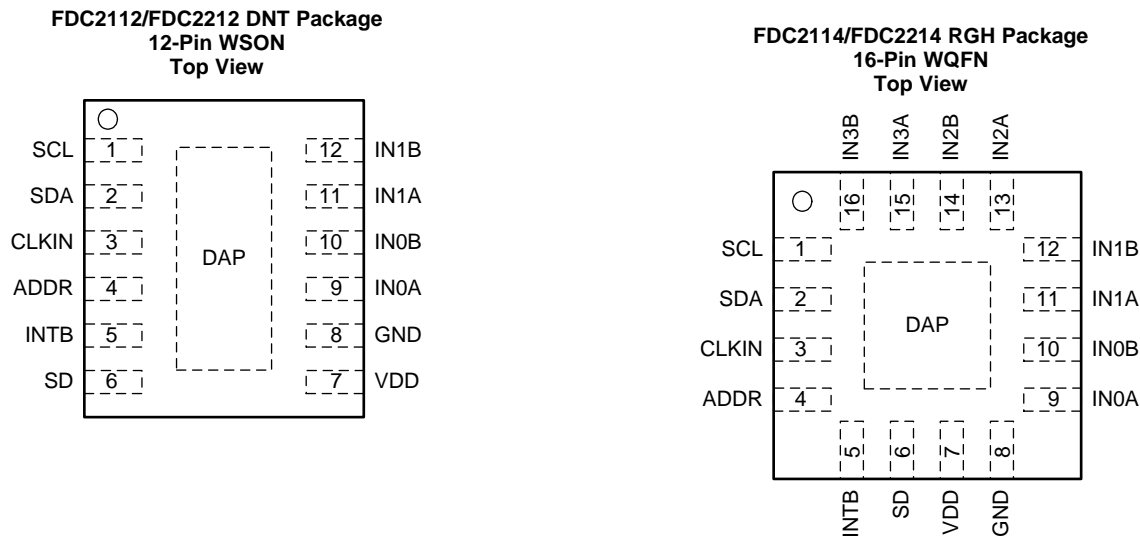

Pin Functions

PIN		TYPE ⁽¹⁾	DESCRIPTION
NO.	NAME		
1	SCL	I	I2C clock input
2	SDA	I/O	I2C data input/output
3	CLKIN	I	Master Clock input. Tie this pin to GND if internal oscillator is selected
4	ADDR	I	I2C Address selection pin: when ADDR=L, I2C address = 0x2A, when ADDR=H, I2C address = 0x2B.
5	INTB	O	Configurable Interrupt output pin
6	SD	I	Shutdown input
7	VDD	P	Power Supply
8	GND	G	Ground
9	IN0A	A	Capacitive sensor input 0
10	IN0B	A	Capacitive sensor input 0
11	IN1A	A	Capacitive sensor input 1
12	IN1B	A	Capacitive sensor input 1
13	IN2A	A	Capacitive sensor input 2 (FDC2114 / FDC2214 only)
14	IN2B	A	Capacitive sensor input 2 (FDC2114 / FDC2214 only)
15	IN3A	A	Capacitive sensor input 3 (FDC2114 / FDC2214 only)
16	IN3B	A	Capacitive sensor input 3 (FDC2114 / FDC2214 only)
DAP	DAP ⁽²⁾	N/A	Connect to ground

(1) I = Input, O = Output, P=Power, G=Ground, A=Analog

(2) There is an internal electrical connection between the exposed Die Attach Pad (DAP) and the GND pin of the device. Although the DAP can be left floating, for best performance the DAP should be connected to the same potential as the device's GND pin. Do not use the DAP as the primary ground for the device. The device GND pin must always be connected to ground.

6 Specifications

6.1 Absolute Maximum Ratings

over operating free-air temperature range (unless otherwise noted)⁽¹⁾

		MIN	MAX	UNIT
VDD	Supply voltage		5	V
V _i	Voltage on any pin	-0.3	VDD + 0.3	V
I _A	Input current on any INx pin	-8	8	mA
I _D	Input current on any digital pin	-5	5	mA
T _J	Junction temperature	-55	150	°C
T _{stg}	Storage temperature	-65	150	°C

- (1) Stresses beyond those listed under *Absolute Maximum Ratings* may cause permanent damage to the device. These are stress ratings only, which do not imply functional operation of the device at these or any other conditions beyond those indicated under *Recommended Operating Conditions*. Exposure to absolute-maximum-rated conditions for extended periods may affect device reliability.

6.2 ESD Ratings

		VALUE	UNIT
V _(ESD)	Electrostatic discharge	Human-body model (HBM), per AEC Q100-002 ⁽¹⁾	±2000
		Charged-device model (CDM), per AEC Q100-011	±750

- (1) AEC Q100-002 indicates that HBM stressing shall be in accordance with the ANSI/ESDA/JEDEC JS-001 specification.

6.3 Recommended Operating Conditions

Unless otherwise specified, all limits ensured for T_A = 25°C, VDD = 3.3 V

		MIN	NOM	MAX	UNIT
VDD	Supply voltage	2.7		3.6	V
T _A	Operating temperature	-40		125	°C

6.4 Thermal Information

THERMAL METRIC ⁽¹⁾		FDC2112 / FDC2212	FDC2214 / FDC2214	UNIT
		DNT (WSON)	RGH (WQFN)	
		12 PINS	16 PINS	
R _{θJA}	Junction-to-ambient thermal resistance	36.7	35.6	°C/W
R _{θJC(top)}	Junction-to-case (top) thermal resistance	36.2	36.2	°C/W
R _{θJB}	Junction-to-board thermal resistance	14	13.4	°C/W
Ψ _{JT}	Junction-to-top characterization parameter	0.4	0.4	°C/W
Ψ _{JB}	Junction-to-board characterization parameter	14.2	13.4	°C/W
R _{θJC(bot)}	Junction-to-case (bottom) thermal resistance	3.5	3.5	°C/W

- (1) For more information about traditional and new thermal metrics, see the *Semiconductor and IC Package Thermal Metrics* application report, [SPRA953](#).

6.5 Electrical Characteristics

Unless otherwise specified, all limits ensured for $T_A = 25^\circ\text{C}$, $V_{DD} = 3.3\text{ V}^{(1)}$

PARAMETER		TEST CONDITIONS ⁽²⁾	MIN ⁽³⁾	TYP ⁽⁴⁾	MAX ⁽³⁾	UNIT
POWER						
V_{DD}	Supply voltage	$T_A = -40^\circ\text{C}$ to 125°C	2.7		3.6	V
I_{DD}	Supply current (not including sensor current) ⁽⁵⁾	$\text{CLKIN} = 10\text{MHz}^{(6)}$		2.1		mA
I_{DDSL}	Sleep mode supply current ⁽⁵⁾			35	60	μA
I_{SD}	Shutdown mode supply current ⁽⁵⁾			0.2	1	μA
CAPACITIVE SENSOR						
$C_{\text{SENSORMAX}}$	Maximum sensor capacitance	1-mH inductor, 10-kHz oscillation		250		nF
C_{IN}	Sensor pin parasitic capacitance			4		pF
N_{BITS}	Number of bits	FDC2112, FDC2114 $\text{RCOUNT} \geq 0x0400$			12	bits
		FDC2212, FDC2214 $\text{RCOUNT} = 0xFFFF$			28	bits
f_{CS}	Maximum channel sample rate	FDC2112, FDC2114 single active channel continuous conversion, $\text{SCL} = 400\text{ kHz}$			13.3	kSPS
		FDC2212, FDC2214 single active channel continuous conversion, $\text{SCL} = 400\text{ kHz}$			4.08	kSPS
EXCITATION						
f_{SENSOR}	Sensor excitation frequency	$T_A = -40^\circ\text{C}$ to 125°C	0.01		10	MHz
$V_{\text{SENSORMIN}}$	Minimum sensor oscillation amplitude (pk) ⁽⁷⁾			1.2		V
$V_{\text{SENSORMAX}}$	Maximum sensor oscillation amplitude (pk)			1.8		V
$I_{\text{SENSORMAX}}$	Sensor maximum current drive	$\text{HIGH_CURRENT_DRV} = b0$ $\text{DRIVE_CURRENT_CH0} = 0xF800$		1.5		mA
		$\text{HIGH_CURRENT_DRV} = b1$ $\text{DRIVE_CURRENT_CH0} = 0xF800$ Channel 0 only		6		mA

- (1) *Electrical Characteristics* values apply only for factory testing conditions at the temperature indicated. Factory testing conditions result in very limited self-heating of the device such that $T_J = T_A$. No guarantee of parametric performance is indicated in the electrical tables under conditions of internal self-heating where $T_J > T_A$. *Absolute Maximum Ratings* indicate junction temperature limits beyond which the device may be permanently degraded, either mechanically or electrically.
- (2) Register values are represented as either binary (b is the prefix to the digits), or hexadecimal (0x is the prefix to the digits). Decimal values have no prefix.
- (3) Limits are ensured by testing, design, or statistical analysis at 25°C . Limits over the operating temperature range are ensured through correlations using statistical quality control (SQC) method.
- (4) Typical values represent the most likely parametric norm as determined at the time of characterization. Actual typical values may vary over time and also depend on the application and configuration. The typical values are not tested and are not ensured on shipped production material.
- (5) I2C read/write communication and pullup resistors current through SCL, SDA not included.
- (6) Sensor capacitor: 1 layer, $20.9 \times 13.9\text{ mm}$, Bourns CMH322522-180KL sensor inductor with $L=18\ \mu\text{H}$ and $33\ \text{pF}$ 1% COG/NP0 Target: Grounded aluminum plate ($176 \times 123\text{ mm}$), Channel = Channel 0 (continuous mode) $\text{CLKIN} = 40\text{ MHz}$, $\text{CHx_FIN_SEL} = b10$, $\text{CHx_FREF_DIVIDER} = b00\ 0000\ 0001$ $\text{CH0_RCOUNT} = 0xFFFF$, $\text{SETTLECOUNT_CH0} = 0x0100$, $\text{DRIVE_CURRENT_CH0} = 0xF800$.
- (7) Lower $V_{\text{SENSORMIN}}$ oscillation amplitudes can be used, but will result in lower SNR.

Electrical Characteristics (continued)

Unless otherwise specified, all limits ensured for $T_A = 25^\circ\text{C}$, $V_{DD} = 3.3\text{ V}^{(1)}$

PARAMETER		TEST CONDITIONS ⁽²⁾	MIN ⁽³⁾	TYP ⁽⁴⁾	MAX ⁽³⁾	UNIT
MASTER CLOCK						
f_{CLKIN}	External master clock input frequency (CLKIN)	$T_A = -40^\circ\text{C}$ to 125°C	2		40	MHz
$\text{CLKIN}_{\text{DUTY_MIN}}$	External master clock minimum acceptable duty cycle (CLKIN)			40%		
$\text{CLKIN}_{\text{DUTY_MAX}}$	External master clock maximum acceptable duty cycle (CLKIN)			60%		
$V_{\text{CLKIN_LO}}$	CLKIN low voltage threshold				$0.3 V_{\text{DD}}$	V
$V_{\text{CLKIN_HI}}$	CLKIN high voltage threshold		$0.7 \times V_{\text{DD}}$			V
f_{INTCLK}	Internal master clock frequency range		35	43.4	55	MHz
$T_{\text{Cf_int_}\mu}$	Internal master clock temperature coefficient mean			-13		ppm/ $^\circ\text{C}$

6.6 Timing Requirements

		MIN	NOM	MAX	UNIT
t_{SDWAKEUP}	Wake-up time from SD high-low transition to I2C readback			2	ms
$t_{\text{SLEEPWAKEUP}}$	Wake-up time from sleep mode			0.05	ms
$t_{\text{WD-TIMEOUT}}$	Sensor recovery time (after watchdog timeout)		5.2		ms
I2C TIMING CHARACTERISTICS					
f_{SCL}	Clock frequency	10		400	kHz
t_{LOW}	Clock low time	1.3			μs
t_{HIGH}	Clock high time	0.6			μs
$t_{\text{HD;STA}}$	Hold time (repeated) START condition: after this period, the first clock pulse is generated	0.6			μs
$t_{\text{SU;STA}}$	Setup time for a repeated START condition	0.6			μs
$t_{\text{HD;DAT}}$	Data hold time	0			μs
$t_{\text{SU;DAT}}$	Data setup time	100			ns
$t_{\text{SU;STO}}$	Setup time for STOP condition	0.6			μs
t_{BUF}	Bus free time between a STOP and START condition	1.3			μs
$t_{\text{VD;DAT}}$	Data valid time			0.9	μs
$t_{\text{VD;ACK}}$	Data valid acknowledge time			0.9	μs
t_{SP}	Pulse width of spikes that must be suppressed by the input filter ⁽¹⁾			50	ns

(1) This parameter is specified by design and/or characterization and is not tested in production.

6.7 Switching Characteristics - I2C

Unless otherwise specified, all limits ensured for $T_A = 25^\circ\text{C}$, $V_{DD} = 3.3\text{ V}$

PARAMETER	TEST CONDITIONS	MIN	TYP	MAX	UNIT
VOLTAGE LEVELS					
V_{IH}	Input high voltage	$0.7 \times V_{DD}$			V
V_{IL}	Input low voltage			$0.3 \times V_{DD}$	V
V_{OL}	Output low voltage (3 mA sink current)			0.4	V
HYS	Hysteresis		$0.1 \times V_{DD}$		V

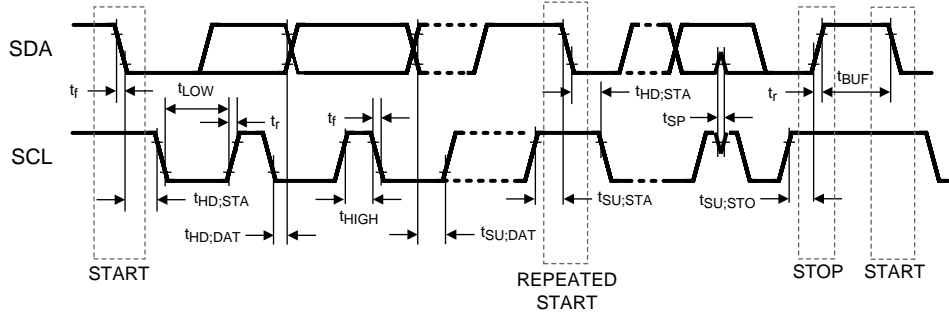
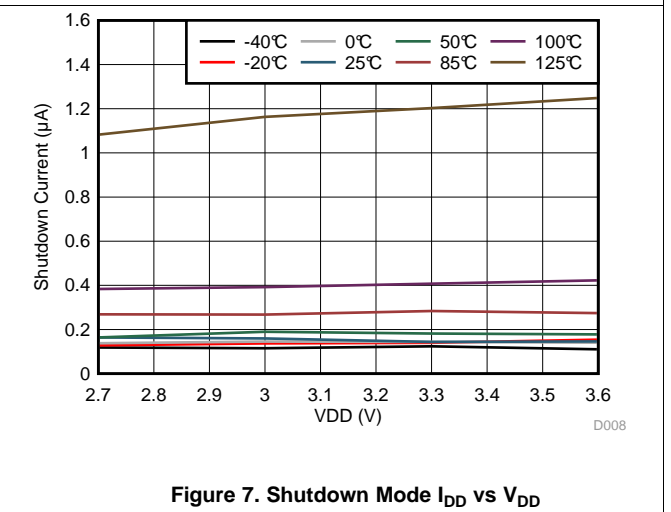
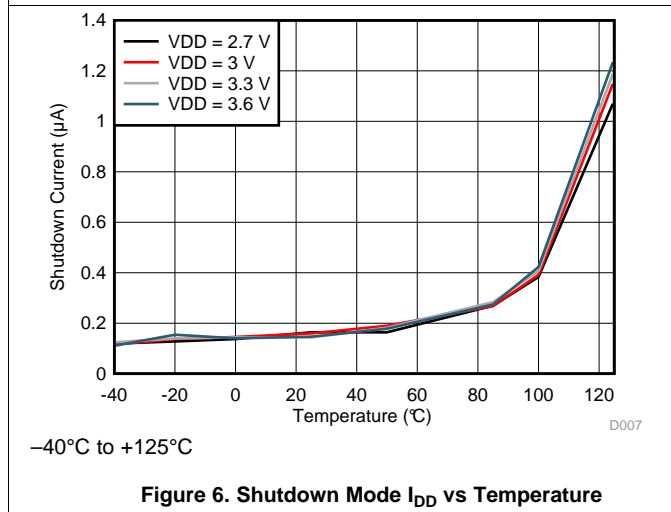
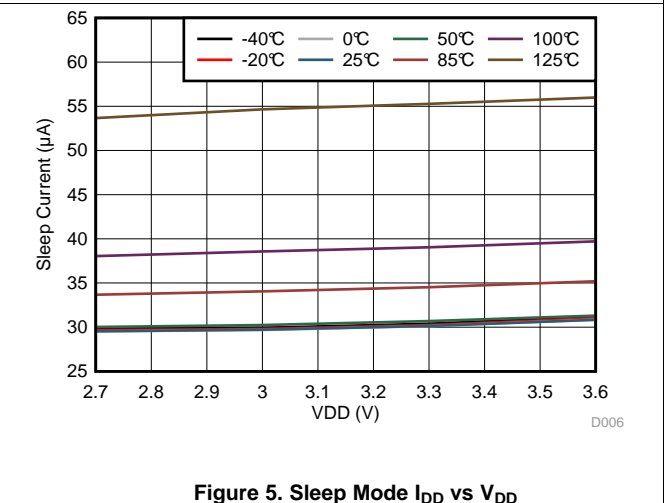
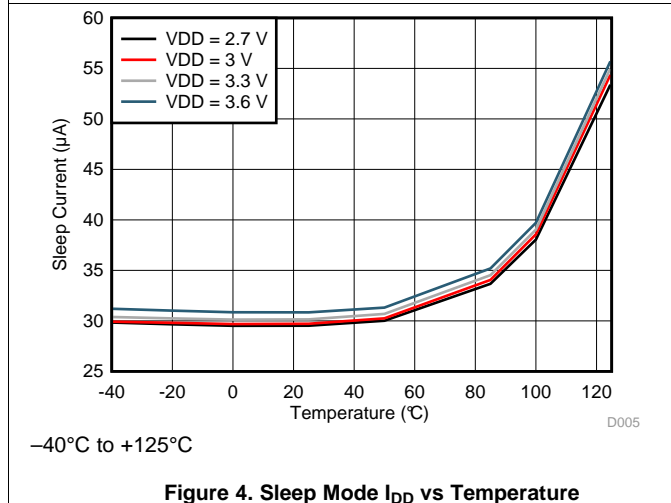
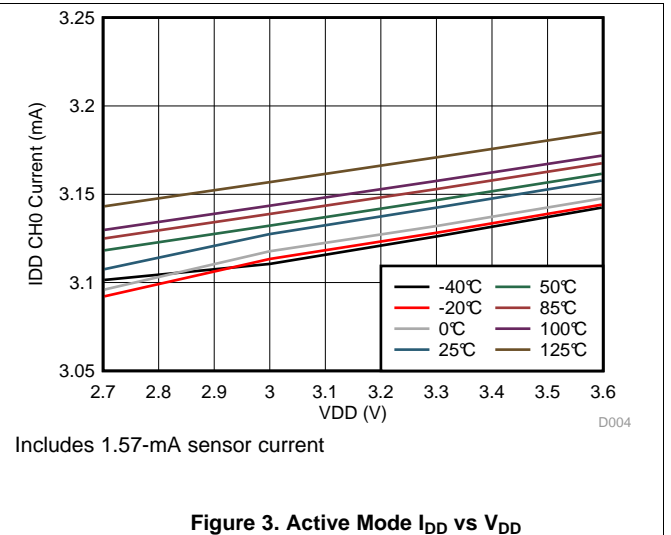
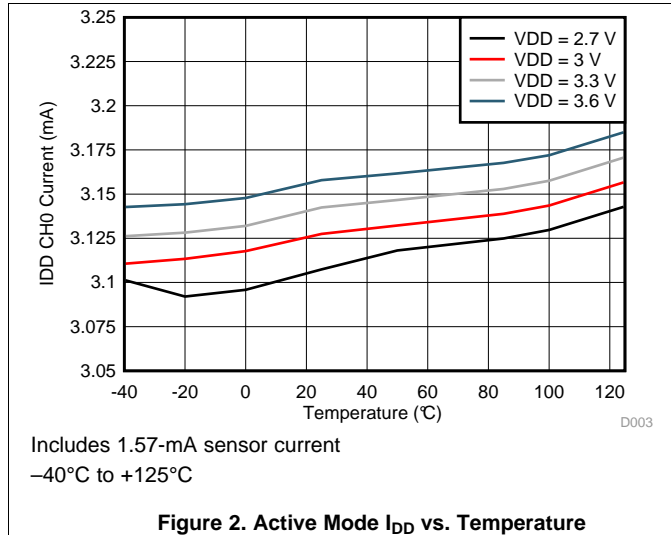

Figure 1. I2C Timing

6.8 Typical Characteristics

Common test conditions (unless specified otherwise): Sensor capacitor: 1 layer, 20.9 × 13.9 mm, Bourns CMH322522-180KL sensor inductor with L = 18 μH and 33 pF 1% COG/NP0 Target: Grounded aluminum plate (176 × 123 mm), Channel = Channel 0 (continuous mode) CLKIN = 40 MHz, CHx_FIN_SEL = b01, CHx_FREF_DIVIDER = b00 0000 0001 CH0_RCOUNT = 0xFFFF, SETTLECOUNT_CH0 = 0x0100, DRIVE_CURRENT_CH0 = 0x7800.



Typical Characteristics (continued)

Common test conditions (unless specified otherwise): Sensor capacitor: 1 layer, 20.9 × 13.9 mm, Bourns CMH322522-180KL sensor inductor with L = 18 μH and 33 pF 1% COG/NP0 Target: Grounded aluminum plate (176 × 123 mm), Channel = Channel 0 (continuous mode) CLKIN = 40 MHz, CHx_FIN_SEL = b01, CHx_FREF_DIVIDER = b00 0000 0001 CH0_RCOUNT = 0xFFFF, SETTLECOUNT_CH0 = 0x0100, DRIVE_CURRENT_CH0 = 0x7800.

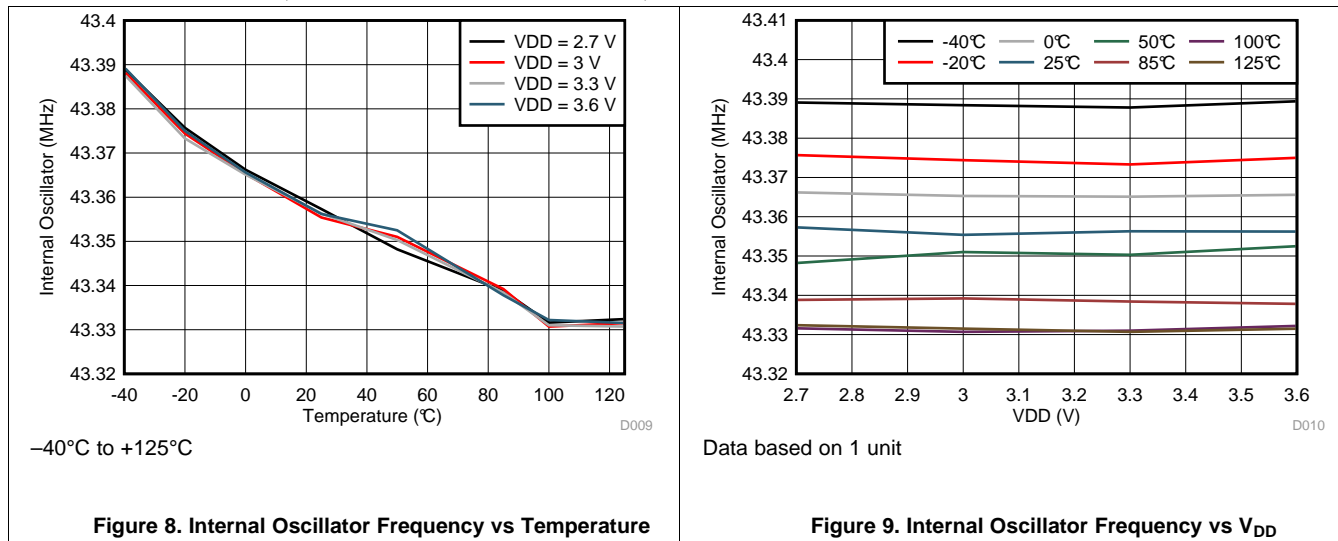

7 Detailed Description

7.1 Overview

The FDC2112, FDC2114, FDC2212, and FDC2214 are high-resolution, multichannel capacitance-to-digital converters for implementing capacitive sensing solutions. In contrast to traditional switched-capacitance architectures, the FDC2112, FDC2114, FDC2212, and FDC2214 employ an L-C resonator, also known as L-C tank, as a sensor. The narrow-band architecture allows unprecedented EMI immunity and greatly reduced noise floor when compared to other capacitive sensing solutions.

Using this approach, a change in capacitance of the L-C tank can be observed as a shift in the resonant frequency. Using this principle, the FDC is a capacitance-to-digital converter (FDC) that measures the oscillation frequency of an LC resonator. The device outputs a digital value that is proportional to frequency. This frequency measurement can be converted to an equivalent capacitance

7.2 Functional Block Diagrams

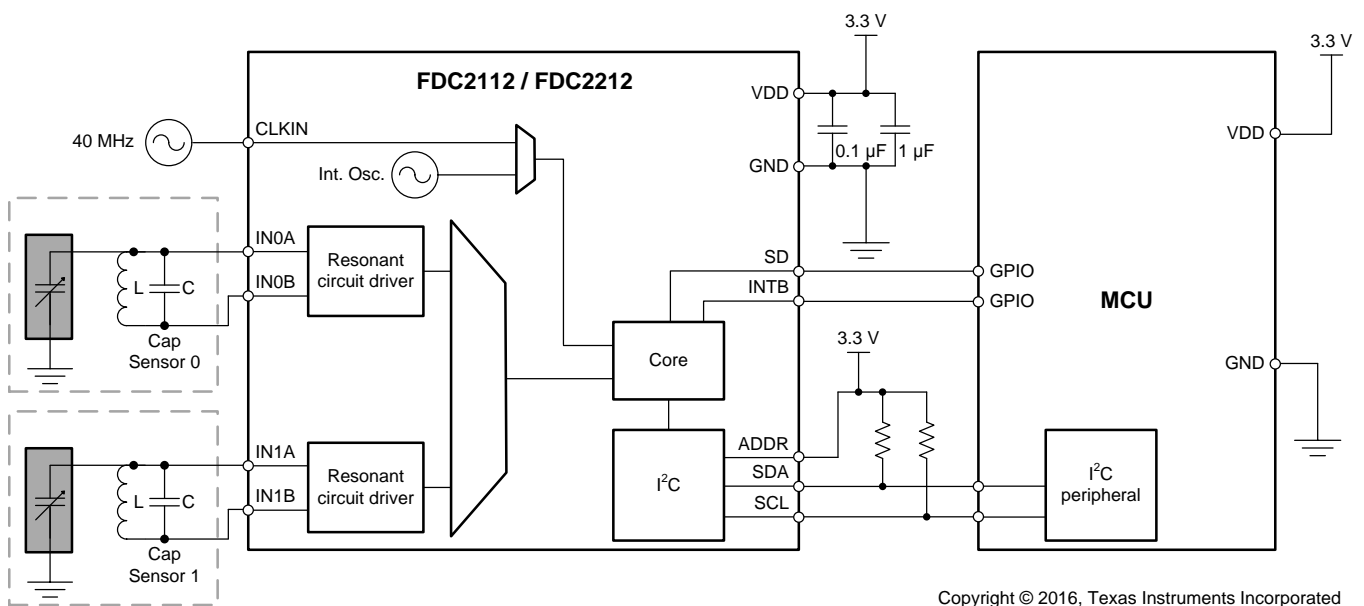

Copyright © 2016, Texas Instruments Incorporated

Figure 10. Block Diagram for the FDC2112 and FDC2212

Functional Block Diagrams (continued)

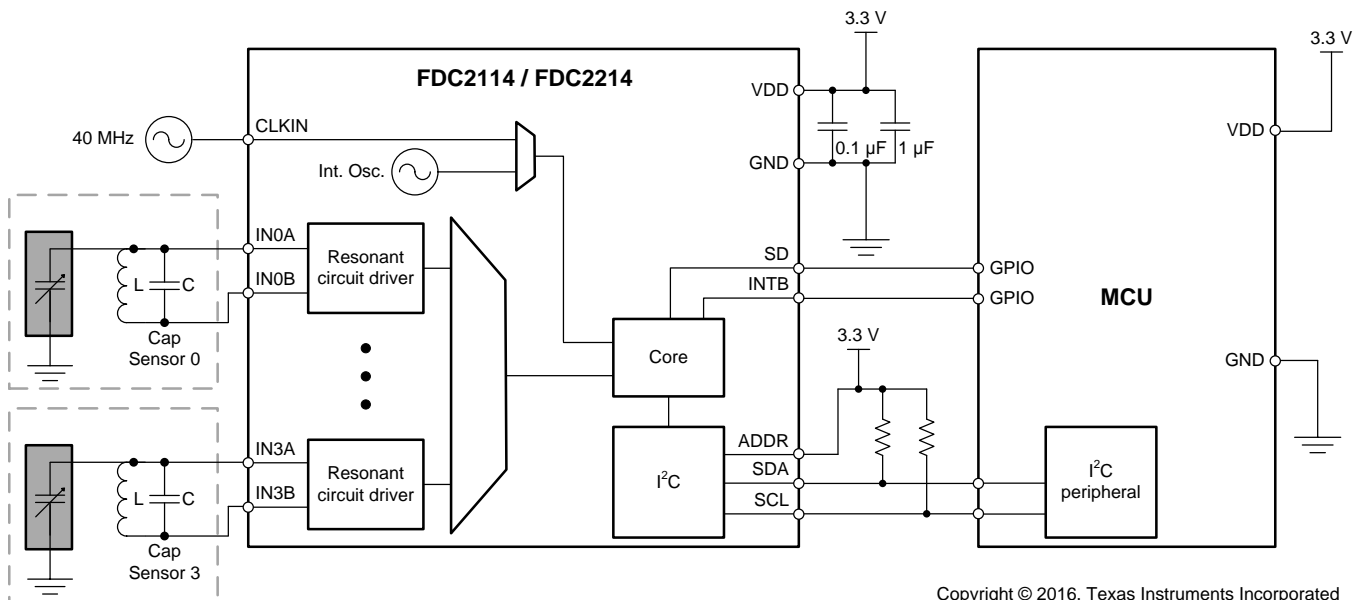

Figure 11. Block Diagram for the FDC2114 and FDC2214

The FDC is composed of front-end resonant circuit drivers, followed by a multiplexer that sequences through the active channels, connecting them to the core that measures and digitizes the sensor frequency (f_{SENSOR}). The core uses a reference frequency (f_{REF}) to measure the sensor frequency. f_{REF} is derived from either an internal reference clock (oscillator), or an externally supplied clock. The digitized output for each channel is proportional to the ratio of $f_{\text{SENSOR}}/f_{\text{REF}}$. The I2C interface is used to support device configuration and to transmit the digitized frequency values to a host processor. The FDC can be placed in shutdown mode, saving current, using the SD pin. The INTB pin may be configured to notify the host of changes in system status.

7.3 Feature Description

7.3.1 Clocking Architecture

Figure 12 shows the clock dividers and multiplexers of the FDC.

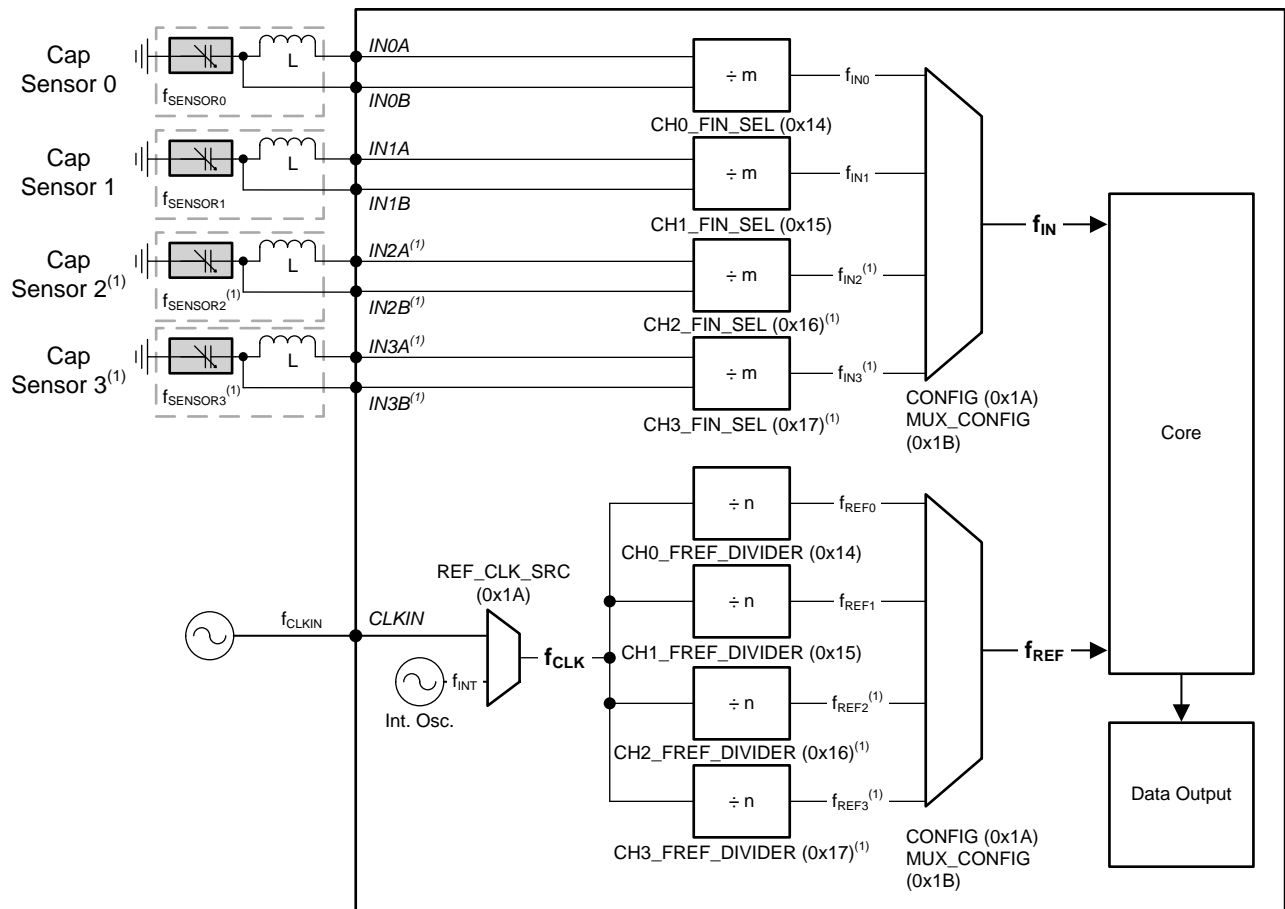
Feature Description (continued)

Copyright © 2016, Texas Instruments Incorporated

(1) FDC2114 / FDC2214 only

Figure 12. Clocking Diagram

In [Figure 12](#), the key clocks are f_{IN} , f_{REF} , and f_{CLK} . f_{CLK} is selected from either the internal clock source or external clock source (CLKIN). The frequency measurement reference clock, f_{REF} , is derived from the f_{CLK} source. TI recommends that precision applications use an external master clock that offers the stability and accuracy requirements needed for the application. The internal oscillator may be used in applications that require low cost and do not require high precision. The f_{INx} clock is derived from sensor frequency for a channel x , $f_{SENSORx} \cdot f_{REFx}$ and f_{INx} must meet the requirements listed in [Table 1](#), depending on whether f_{CLK} (master clock) is the internal or external clock.

Feature Description (continued)
Table 1. Clock Configuration Requirements

MODE ⁽¹⁾	CLKIN SOURCE	VALID f_{REFx} RANGE (MHz)	VALID f_{INx} RANGE	SET CHx_FIN_SEL to ⁽²⁾	SET CHx_SETTLECO UNT to	SET CHx_RCOUNT to
Multi-channel	Internal	$f_{REFx} \leq 55$	$< f_{REFx} / 4$	Differential sensor configuration: b01: 0.01MHz to 8.75MHz (divide by 1) b10: 5MHz to 10MHz (divide by 2) Single-ended sensor configuration b10: 0.01MHz to 10MHz (divide by 2)	> 3	> 8
	External	$f_{REFx} \leq 40$				
Single-channel	Either external or internal	$f_{REFx} \leq 35$				

(1) Channels 2 and 3 are only available for FDC2114 and FDC2214.

(2) Refer to [Sensor Configuration](#) for information on differential and single-ended sensor configurations.

[Table 2](#) shows the clock configuration registers for all channels.

Table 2. Clock Configuration Registers

CHANNEL ⁽¹⁾	CLOCK	REGISTER	FIELD [BIT(S)]	VALUE
All	f_{CLK} = Master Clock Source	CONFIG, addr 0x1A	REF_CLK_SRC [9]	b0 = internal oscillator is used as the master clock b1 = external clock source is used as the master clock
0	f_{REF0}	CLOCK_DIVIDER S_CH0, addr 0x14	CH0_FREF_DIVIDER [9:0]	$f_{REF0} = f_{CLK} / CH0_FREF_DIVIDER$
1	f_{REF1}	CLOCK_DIVIDER S_CH1, addr 0x15	CH1_FREF_DIVIDER [9:0]	$f_{REF1} = f_{CLK} / CH1_FREF_DIVIDER$
2	f_{REF2}	CLOCK_DIVIDER S_CH2, addr 0x16	CH2_FREF_DIVIDER [9:0]	$f_{REF2} = f_{CLK} / CH2_FREF_DIVIDER$
3	f_{REF3}	CLOCK_DIVIDER S_CH3, addr 0x17	CH3_FREF_DIVIDER [9:0]	$f_{REF3} = f_{CLK} / CH3_FREF_DIVIDER$
0	f_{IN0}	CLOCK_DIVIDER S_CH0, addr 0x14	CH0_FIN_SEL [13:12]	$f_{IN0} = f_{SENSOR0} / CH0_FIN_SEL$
1	f_{IN1}	CLOCK_DIVIDER S_CH1, addr 0x15	CH1_FIN_SEL [13:12]	$f_{IN1} = f_{SENSOR1} / CH1_FIN_SEL$
2	f_{IN2}	CLOCK_DIVIDER S_CH2, addr 0x16	CH2_FIN_SEL [13:12]	$f_{IN2} = f_{SENSOR2} / CH2_FIN_SEL$
3	f_{IN3}	CLOCK_DIVIDER S_CH3, addr 0x17	CH3_FIN_SEL [13:12]	$f_{IN3} = f_{SENSOR3} / CH3_FIN_SEL$

(1) Channels 2 and 3 are only available for FDC2114 and FDC2214

7.3.2 Multi-Channel and Single-Channel Operation

The multi-channel package of the FDC enables the user to save board space and support flexible system design. For example, temperature drift can often cause a shift in component values, resulting in a shift in resonant frequency of the sensor. Using a second sensor as a reference provides the capability to cancel out a temperature shift. When operated in multi-channel mode, the FDC sequentially samples the active channels. In single-channel mode, the FDC samples a single channel, which is selectable. [Table 3](#) shows the registers and values that are used to configure either multi-channel or single-channel modes.

Table 3. Single- and Multi-Channel Configuration Registers

MODE	REGISTER	FIELD [BIT(S)]	VALUE
Single channel	CONFIG, addr 0x1A	ACTIVE_CHAN [15:14]	00 = chan 0
			01 = chan 1
			10 = chan 2
			11 = chan 3
	MUX_CONFIG addr 0x1B	AUTOSCAN_EN [15]	0 = continuous conversion on a single channel (default)
Multi-channel	MUX_CONFIG addr 0x1B	AUTOSCAN_EN [15]	1 = continuous conversion on multiple channels
	MUX_CONFIG addr 0x1B	RR_SEQUENCE [14:13]	00 = Ch0, Ch 1
			01 = Ch0, Ch 1, Ch 2
			10 = Ch0, CH1, Ch2, Ch3

The digitized sensor measurement for each channel (DATA_x) represents the ratio of the sensor frequency to the reference frequency.

The data output (DATA_x) of the FDC2112 and FDC2114 is expressed as the 12 MSBs of a 16-bit result:

$$DATA_x = \frac{f_{SENSORx} * 2^{12}}{f_{REFx}} \quad (1)$$

The data output (DATA_x) of the FDC2212 and FDC2214 is expressed as:

$$DATA_x = \frac{f_{SENSORx} * 2^{28}}{f_{REFx}} \quad (2)$$

Table 4 lists the registers that contain the fixed point sample values for each channel.

Table 4. Sample Data Registers

CHANNEL ⁽¹⁾	REGISTER ⁽²⁾	FIELD NAME [BITS(S)] AND VALUE (FDC2112, FDC2114)	FIELD NAME [BITS(S)] AND VALUE (FDC2212, FDC2214) ⁽³⁾⁽⁴⁾
0	DATA_CH0, addr 0x00	DATA0 [11:0]: 12 bits of the 16 bit conversion result. 0x000 = under range 0xfff = over range	DATA0 [27:16]: 12 MSBs of the 28 bit conversion result
	DATA_LSB_CH0, addr 0x01	Not applicable	DATA0 [15:0]: 16 LSBs of the 28 bit conversion result
1	DATA_CH1, addr 0x02	DATA1 [11:0]: 12 bits of the 16 bit conversion result. 0x000 = under range 0xfff = over range	DATA1 [27:16]: 12 MSBs of the 28 bit conversion result
	DATA_LSB_CH1, addr 0x03	Not applicable	DATA1 [15:0]: 16 LSBs of the 28 bit conversion result
2	DATA_CH2, addr 0x04	DATA2 [11:0]: 12 bits of the 16 bit conversion result. 0x000 = under range 0xfff = over range	DATA2 [27:16]: 12 MSBs of the 28 bit conversion result
	DATA_LSB_CH2, addr 0x05	Not applicable	DATA2 [15:0]: 16 LSBs of the 28 bit conversion result

(1) Channels 2 and 3 are only available for FDC2114 and FDC2214.

(2) The DATA_CHx.DATAx register must always be read first, followed by the DATA_LSB_CHx.DATAx register of the same channel to ensure data coherency.

(3) A DATA value of 0x0000000 = under range for FDC2212/FDC2214.

(4) A DATA value of 0xFFFFFFFF = over range for FDC2212/FDC2214.

Table 4. Sample Data Registers (continued)

CHANNEL ⁽¹⁾	REGISTER ⁽²⁾	FIELD NAME [BITS(S)] AND VALUE (FDC2112, FDC2114)	FIELD NAME [BITS(S)] AND VALUE (FDC2212, FDC2214) ⁽³⁾⁽⁴⁾
3	DATA_CH3, addr 0x06	DATA3 [11:0]: 12 bits of the 16 bit conversion result. 0x000 = under range 0xfff = over range	DATA3 [27:16]: 12 MSBs of the 28 bit conversion result
	DATA_LSB_CH3, addr 0x07	Not applicable	DATA3 [15:0]: 16 LSBs of the 28 bit conversion result

When the FDC sequences through the channels in multi-channel mode, the dwell time interval for each channel is the sum of three parts:

1. sensor activation time
2. conversion time
3. channel switch delay

The sensor activation time is the amount of settling time required for the sensor oscillation to stabilize, as shown in Figure 13. The settling wait time is programmable and should be set to a value that is long enough to allow stable oscillation. The settling wait time for channel x is given by:

$$t_{sx} = (CHX_SETTLECOUNT \times 16) / f_{REFx} \tag{3}$$

Table 5 illustrates the registers and values for configuring the settling time for each channel.

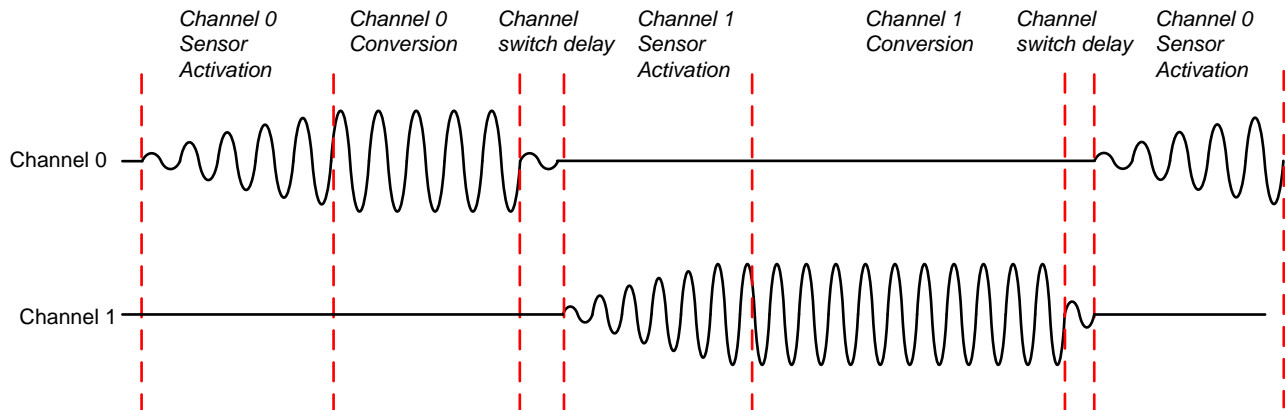

Figure 13. Multi-channel Mode Sequencing

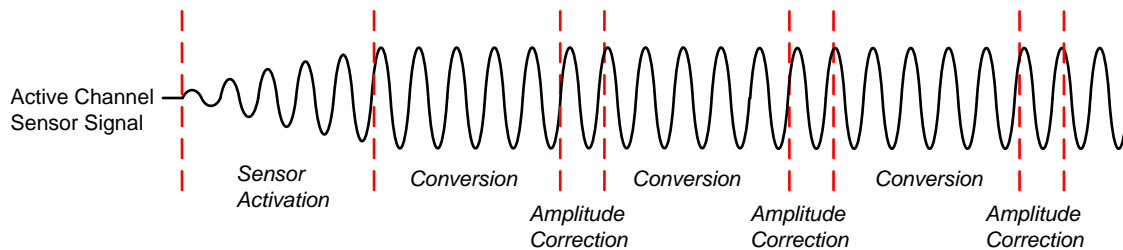

Figure 14. Single-channel Mode Sequencing

Table 5. Settling Time Register Configuration

CHANNEL ⁽¹⁾	REGISTER	FIELD	CONVERSION TIME ⁽²⁾
0	SETTLECOUNT_CH0, addr 0x10	CH0_SETTLECOUNT [15:0]	(CH0_SETTLECOUNT*16)/f _{REF0}
1	SETTLECOUNT_CH1, addr 0x11	CH1_SETTLECOUNT [15:0]	(CH1_SETTLECOUNT*16)/f _{REF1}
2	SETTLECOUNT_CH2, addr 0x12	CH2_SETTLECOUNT [15:0]	(CH2_SETTLECOUNT*16)/f _{REF2}
3	SETTLECOUNT_CH3, addr 0x13	CH3_SETTLECOUNT [15:0]	(CH3_SETTLECOUNT*16)/f _{REF3}

(1) Channels 2 and 3 are available only in the FDC2114 and FDC2214.

(2) f_{REFx} is the reference frequency configured for the channel.

The SETTLECOUNT for any channel x must satisfy:

$$\text{CH}_x\text{_SETTLECOUNT} > V_{\text{pk}} \times f_{\text{REFx}} \times C \times \pi^2 / (32 \times \text{IDRIVE}_x)$$

where

- V_{pk} = Peak oscillation amplitude at the programmed IDRIVE setting
 - f_{REFx} = Reference frequency for Channel x
 - C = sensor capacitance including parasitic PCB capacitance
 - IDRIVE_x = setting programmed into the IDRIVE register in amps
- (4)

Round the result to the next highest integer (for example, if Equation 4 recommends a minimum value of 6.08, program the register to 7 or higher).

The conversion time represents the number of reference clock cycles used to measure the sensor frequency. It is set by the CHx_RCOUNT register for the channel. The conversion time for any channel x is:

$$t_{\text{Cx}} = (\text{CH}_x\text{_RCOUNT} \times 16 + 4) / f_{\text{REFx}}$$

(5)

The reference count value must be chosen to support the required number of effective bits (ENOB). For example, if an ENOB of 13 bits is required, then a minimum conversion time of 2¹³ = 8192 clock cycles is required. 8192 clock cycles correspond to a CHx_RCOUNT value of 0x0200.

Table 6. Conversion Time Configuration Registers, Channels 0 - 3⁽¹⁾

CHANNEL	REGISTER	FIELD [BIT(S)]	CONVERSION TIME
0	RCOUNT_CH0, addr 0x08	CH0_RCOUNT [15:0]	(CH0_RCOUNT × 16)/f _{REF0}
1	RCOUNT_CH1, addr 0x09	CH1_RCOUNT [15:0]	(CH1_RCOUNT × 16)/f _{REF1}
2	RCOUNT_CH2, addr 0x0A	CH2_RCOUNT [15:0]	(CH2_RCOUNT × 16)/f _{REF2}
3	RCOUNT_CH3, addr 0x0B	CH3_RCOUNT [15:0]	(CH3_RCOUNT × 16)/f _{REF3}

(1) Channels 2 and 3 are available only for FDC2114 and FDC2214.

The typical channel switch delay time between the end of conversion and the beginning of sensor activation of the subsequent channel is:

$$\text{Channel Switch Delay} = 692 \text{ ns} + 5 / f_{\text{ref}}$$

(6)

The deterministic conversion time of the FDC allows data polling at a fixed interval. For example, if the programmed SETTLECOUNT is 128 F_{REF} cycles (SETTLECOUNT = 0x0008) and RCOUNT is 512 F_{REF} cycles (RCOUNT=0x0020), then one conversion takes 3.2 ms (sensor-activation time) + 12.8ms (conversion time) + 0.8μs (channel-switch delay) = 16.0 ms per channel. If the FDC is configured for dual-channel operation by setting AUTOSCAN_EN = 1 and RR_SEQUENCE = 00, then one full set of conversion results will be available from the data registers every 32 ms.

A data ready flag (DRDY) is also available for interrupt driven system designs (see the STATUS register description in [Register Maps](#)).

7.3.2.1 Gain and Offset (FDC2112, FDC2114 only)

The FDC2112 and FDC2114 have internal 16-bit data converters, but the standard conversion output word width is only 12 bits; therefore only 12 of the 16 bits are available from the data registers. By default, the gain feature is disabled and the DATA registers contain the 12 MSBs of the 16-bit word. However, it is possible to shift the data output by up to 4 bits. Figure 15 shows the segment of the 16-bit sample that is reported for each possible gain setting.

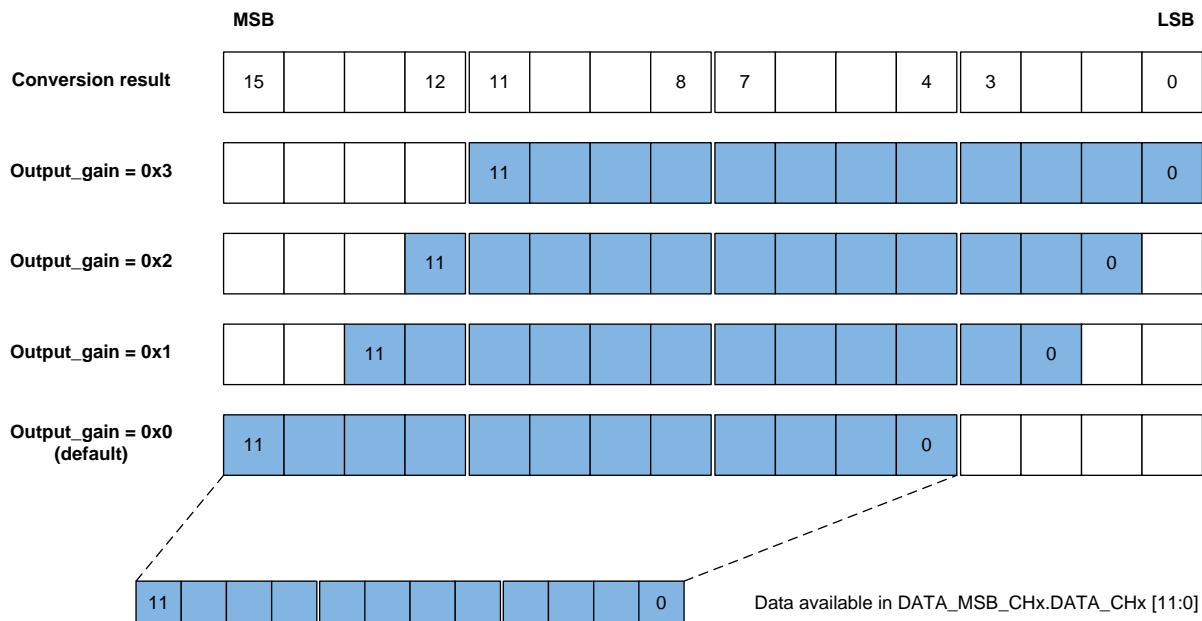
Figure 15. Conversion Data Output Gain

For systems in which the sensor signal variation is less than 25% of the full-scale range, the FDC can report conversion results with higher resolution by setting the output gain. The output gain is applied to all device channels. An output gain can be used to apply a 2-bit, 3-bit, or 4-bit shift to the output code for all channels, allowing access to the 4 LSBs of the original 16-bit result. The MSBs of the sample are shifted out when a gain is applied. Do not use the output gain if the MSBs of any active channel are toggling, as the MSBs for that channel will be lost when gain is applied.

Example: If the conversion result for a channel is 0x07A3, with OUTPUT_GAIN = 0x0, the reported output code is 0x07A. If OUTPUT_GAIN is set to 0x3 in the same condition, then the reported output code is 0x7A3. The original 4 MSBs (0x0) are no longer accessible.

Table 7. Output Gain Register (FDC2112 and FDC2114 only)

CHANNEL ⁽¹⁾	REGISTER	FIELD [BIT(S)]	VALUES	EFFECTIVE RESOLUTION (BITS)	OUTPUT RANGE
All	RESET_DEV, addr 0x1C	OUTPUT_GAIN [10:9]	00 (default): Gain =1 (0 bits shift)	12	100% full scale
			01: Gain = 4 (2 bits left shift)	14	25% full scale
			10: Gain = 8 (3 bits left shift)	15	12.5% full scale
			11 : Gain = 16 (4 bits left shift)	16	6.25% full scale

(1) Channels 2 and 3 are available for FDC2114 only.

An offset value may be subtracted from each DATA value to compensate for a frequency offset or maximize the dynamic range of the sample data. The offset values should be $< f_{\text{SENSORx_MIN}} / f_{\text{REFx}}$. Otherwise, the offset might be so large that it masks the LSBs which are changing.

Table 8. Frequency Offset Registers

CHANNEL ⁽¹⁾	REGISTER	FIELD [BIT(S)]	VALUE
0	OFFSET_CH0, addr 0x0C	CH0_OFFSET [15:0]	$f_{\text{OFFSET0}} = \text{CH0_OFFSET} \times (f_{\text{REF0}}/2^{16})$
1	OFFSET_CH1, addr 0x0D	CH1_OFFSET [15:0]	$f_{\text{OFFSET1}} = \text{CH1_OFFSET} \times (f_{\text{REF1}}/2^{16})$
2	OFFSET_CH2, addr 0x0E	CH2_OFFSET [15:0]	$f_{\text{OFFSET2}} = \text{CH2_OFFSET} \times (f_{\text{REF2}}/2^{16})$
3	OFFSET_CH3, addr 0x0F	CH3_OFFSET [15:0]	$f_{\text{OFFSET3}} = \text{CH3_OFFSET} \times (f_{\text{REF3}}/2^{16})$

(1) Channels 2 and 3 are only available for FDC2114 and FDC2214.

The sensor capacitance C_{SENSE} of a differential sensor configuration can be determined by:

$$C_{\text{SENSOR}} = \frac{1}{L * (2\pi * f_{\text{SENSORx}})^2} - C$$

where

- C = parallel sensor capacitance (see [Figure 55](#)) (7)

The FDC2112 and FDC2114 sensor frequency f_{SENSORx} can be determined by:

$$f_{\text{SENSORx}} = \text{CHx_FIN_SEL} * f_{\text{REFx}} * \left(\frac{\text{DATAx}}{2^{(12+\text{OUTPUT_GAIN})}} + \frac{\text{CHx_OFFSET}}{2^{16}} \right)$$

where

- DATAx = Conversion result from the DATA_CHx register
- CHx_OFFSET = Offset value set in the OFFSET_CHx register
- OUTPUT_GAIN = output multiplication factor set in the RESET_DEVICE.OUTPUT_GAIN register (8)

The FDC2212 and FDC2214 sensor frequency f_{SENSORx} can be determined by:

$$f_{\text{SENSORx}} = \frac{\text{CHx_FIN_SEL} * f_{\text{REFx}} * \text{DATAx}}{2^{28}} \quad (\text{FDC2212, FDC2214})$$

where

- DATAx = Conversion result from the DATA_CHx register (9)

7.3.3 Current Drive Control Registers

The registers listed in [Table 9](#) are used to control the sensor drive current. The recommendations listed in the last column of the table should be followed.

Table 9. Current Drive Control Registers

CHANNEL ⁽¹⁾	REGISTER	FIELD [BIT(S)]	VALUE
All	CONFIG, addr 0x1A	SENSOR_ACTIVATE_SEL [11]	Sets current drive for sensor activation. Recommended value is b0 (full current mode).
0	CONFIG, addr 0x1A	HIGH_CURRENT_DRV [6]	b0 = normal current drive (1.5 mA) b1 = Increased current drive (> 1.5 mA) for Ch 0 in single channel mode only. Cannot be used in multi-channel mode.
0	DRIVE_CURRENT_CH0, addr 0x1E	CH0_IDRIVE [15:11]	Drive current used during the settling and conversion time for Ch. 0. Set such that $1.2\text{ V} \leq \text{sensor oscillation amplitude (pk)} \leq 1.8\text{ V}$
1	DRIVE_CURRENT_CH1, addr 0x1F	CH1_IDRIVE [15:11]	Drive current used during the settling and conversion time for Ch. 1. Set such that $1.2\text{ V} \leq \text{sensor oscillation amplitude (pk)} \leq 1.8\text{ V}$
2	DRIVE_CURRENT_CH2, addr 0x20	CH2_IDRIVE [15:11]	Drive current used during the settling and conversion time for Ch. 2. Set such that $1.2\text{ V} \leq \text{sensor oscillation amplitude (pk)} \leq 1.8\text{ V}$
3	DRIVE_CURRENT_CH3, addr 0x21	CH3_IDRIVE [15:11]	Drive current used during the settling and conversion time for Ch. 3. Set such that $1.2\text{ V} \leq \text{sensor oscillation amplitude (pk)} \leq 1.8\text{ V}$

(1) Channels 2 and 3 are available for FDC2114 and FDC2214 only.

The CH_x_IDRIVE field should be programmed such that the sensor oscillates at an amplitude between 1.2 V_{pk} (V_{SENSORMIN}) and 1.8 V_{pk} (V_{SENSORMAX}). An IDRIVE value of 00000 corresponds to 16 μA, and IDRIVE = b11111 corresponds to 1563 μA.

A high sensor current drive mode can be enabled to drive sensor coils with > 1.5mA on channel 0, only in single channel mode. This feature can be used when the sensor minimum recommended oscillation amplitude of 1.2V cannot be achieved with the highest IDRIVE setting. Set the HIGH_CURRENT_DRV register bit to b1 to enable this mode.

7.3.4 Device Status Registers

The registers listed in [Table 10](#) may be used to read device status.

Table 10. Status Registers

CHANNEL ⁽¹⁾	REGISTER	FIELDS [BIT(S)]	VALUES
All	STATUS, addr 0x18	12 fields are available that contain various status bits [15:0]	Refer to Register Maps for a description of the individual status bits.
All	STATUS_CONFIG, addr 0x19	12 fields are available that are used to configure status reporting [15:0]	Refer to Register Maps for a description of the individual error configuration bits.

(1) Channels 2 and 3 are available for FDC2114 and FDC2114 only.

See the STATUS and STATUS_CONFIG register description in [Register Maps](#). These registers can be configured to trigger an interrupt on the INTB pin for certain events. The following conditions must be met:

1. The error or status register must be unmasked by enabling the appropriate register bit in the STATUS_CONFIG register
2. The INTB function must be enabled by setting CONFIG.INTB_DIS to 0

When a bit field in the STATUS register is set, the entire STATUS register content is held until read or until the DATA_CHx register is read. Reading also de-asserts INTB.

Interrupts are cleared by one of the following events:

1. Entering sleep mode
2. Power-on reset (POR)
3. Device enters shutdown mode (SD is asserted)
4. S/W reset
5. I2C read of the STATUS register: Reading the STATUS register clears any error status bit set in STATUS along with the ERR_CHAN field and de-assert INTB

Setting register CONFIG.INTB_DIS to b1 disables the INTB function and holds the INTB pin high.

7.3.5 Input Deglitch Filter

The input deglitch filter suppresses EMI and ringing above the sensor frequency. It does not impact the conversion result as long as its bandwidth is configured to be above the maximum sensor frequency. The input deglitch filter can be configured in MUX_CONFIG.DEGLITCH register field as shown in Table 11. For optimal performance, TI recommends selection of the lowest setting that exceeds the sensor oscillation frequency. For example, if the maximum sensor frequency is 2 MHz, choose MUX_CONFIG.DEGLITCH = b100 (3.3 MHz).

Table 11. Input Deglitch Filter Register

CHANNEL ⁽¹⁾	MUX_CONFIG.DEGLITCH (addr 0x1B) REGISTER VALUE	DEGLITCH FREQUENCY
ALL	001	1 MHz
ALL	100	3.3 MHz
ALL	101	10 MHz
ALL	011	33 MHz

(1) Channels 2 and 3 are available for FDC2114 / FDC2214 only.

7.4 Device Functional Modes

7.4.1 Start-Up Mode

When the FDC powers up, it enters into sleep mode and waits for configuration. Once the device is configured, exit sleep mode by setting CONFIG.SLEEP_MODE_EN to b0.

TI recommends configuring the FDC while in sleep mode. If a setting on the FDC needs to be changed, return the device to sleep mode, change the appropriate register, and then exit sleep mode.

7.4.2 Normal (Conversion) Mode

When operating in the normal (conversion) mode, the FDC is periodically sampling the frequency of the sensor(s) and generating sample outputs for the active channel(s).

7.4.3 Sleep Mode

Sleep mode is entered by setting the CONFIG.SLEEP_MODE_EN register field to 1. While in this mode, the device configuration is maintained. To exit sleep mode, set the CONFIG.SLEEP_MODE_EN register field to 0. After setting CONFIG.SLEEP_MODE_EN to b0, sensor activation for the first conversion begins after 16,384 f_{INT} clock cycles. While in sleep mode the I2C interface is functional so that register reads and writes can be performed. While in sleep mode, no conversions are performed. In addition, entering sleep mode will clear conversion results, any error condition, and de-assert the INTB pin.

7.4.4 Shutdown Mode

When the SD pin is set to high, the FDC enters shutdown mode. Shutdown mode is the lowest power state. To exit shutdown mode, set the SD pin to low. Entering shutdown mode returns all registers to their default state.

Device Functional Modes (continued)

While in shutdown mode, no conversions are performed. In addition, entering shutdown mode clears any error condition and de-assert the INTB pin. While the device is in shutdown mode, is not possible to read to or write from the device via the I2C interface.

7.4.4.1 Reset

The FDC can be reset by writing to RESET_DEV.RESET_DEV. Any active conversion stops, and all register values return to their default value. This register bit always returns 0b when read.

7.5 Programming

The FDC device uses an I2C interface to access control and data registers.

7.5.1 I2C Interface Specifications

The FDC uses an extended start sequence with I2C for register access. The maximum speed of the I2C interface is 400 kbit/s. This sequence follows the standard I2C 7-bit slave address followed by an 8-bit pointer register byte to set the register address. When the ADDR pin is set low, the FDC I2C address is 0x2A; when the ADDR pin is set high, the FDC I2C address is 0x2B. The ADDR pin must not change state after the FDC exits Shutdown Mode.

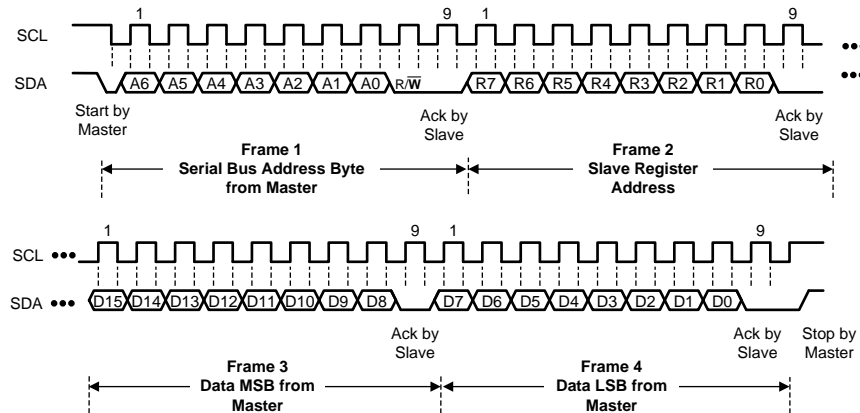

Figure 16. I2C Write Register Sequence

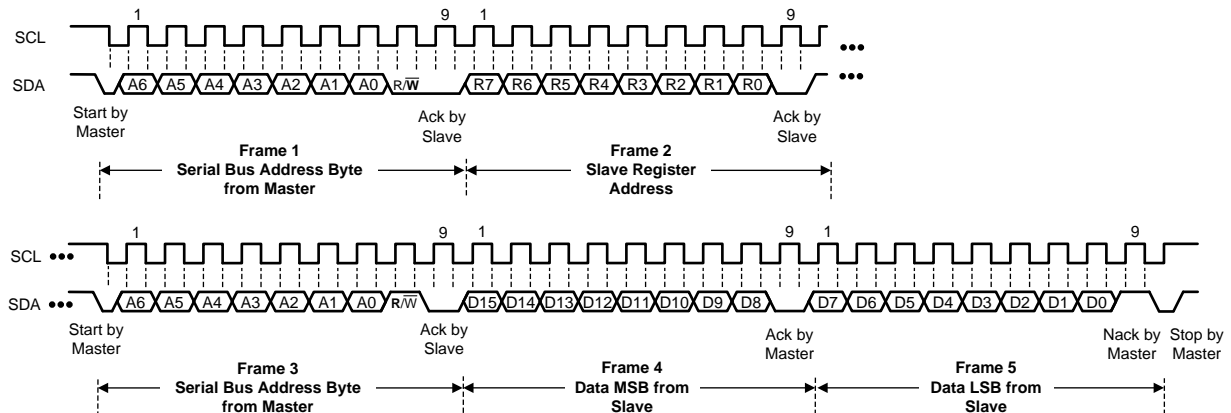

Figure 17. I2C Read Register Sequence

7.6 Register Maps

7.6.1 Register List

Fields indicated with Reserved must be written only with indicated values, otherwise improper device operation may occur. The R/W column indicates the Read-Write status of the corresponding field. A 'R/W' entry indicates read and write capability, a 'R' indicates read-only, and a 'W' indicates write-only.

Figure 18. Register List

ADDRESS	NAME	DEFAULT VALUE	DESCRIPTION
0x00	DATA_CH0	0x0000	Channel 0 Conversion Result and status (FDC2112 / FDC2114 only)
		0x0000	Channel 0 MSB Conversion Result and status (FDC2212 / FDC2214 only)
0x01	DATA_LSB_CH0	0x0000	Channel 0 LSB Conversion Result. Must be read after Register address 0x00 (FDC2212 / FDC2214 only)
0x02	DATA_CH1	0x0000	Channel 1 Conversion Result and status (FDC2112 / FDC2114 only)
		0x0000	Channel 1 MSB Conversion Result and status (FDC2212 / FDC2214 only)
0x03	DATA_LSB_CH1	0x0000	Channel 1 LSB Conversion Result. Must be read after Register address 0x02 (FDC2212 / FDC2214 only)
0x04	DATA_CH2	0x0000	Channel 2 Conversion Result and status (FDC2114 only)
		0x0000	Channel 2 MSB Conversion Result and status (FDC2214 only)
0x05	DATA_LSB_CH2	0x0000	Channel 2 LSB Conversion Result. Must be read after Register address 0x04 (FDC2214 only)
0x06	DATA_CH3	0x0000	Channel 3 Conversion Result and status (FDC2114 only)
		0x0000	Channel 3 MSB Conversion Result and status (FDC2214 only)
0x07	DATA_LSB_CH3	0x0000	Channel 3 LSB Conversion Result. Must be read after Register address 0x06 (FDC2214 only)
0x08	RCOUNT_CH0	0x0080	Reference Count setting for Channel 0
0x09	RCOUNT_CH1	0x0080	Reference Count setting for Channel 1
0x0A	RCOUNT_CH2	0x0080	Reference Count setting for Channel 2 (FDC2114 / FDC2214 only)
0x0B	RCOUNT_CH3	0x0080	Reference Count setting for Channel 3 (FDC2114 / FDC2214 only)
0x0C	OFFSET_CH0	0x0000	Offset value for Channel 0 (FDC2112 / FDC2114 only)
0x0D	OFFSET_CH1	0x0000	Offset value for Channel 1 (FDC2112 / FDC2114 only)
0x0E	OFFSET_CH2	0x0000	Offset value for Channel 2 (FDC2114 only)
0x0F	OFFSET_CH3	0x0000	Offset value for Channel 3 (FDC2114 only)
0x10	SETTLECOUNT_CH0	0x0000	Channel 0 Settling Reference Count
0x11	SETTLECOUNT_CH1	0x0000	Channel 1 Settling Reference Count
0x12	SETTLECOUNT_CH2	0x0000	Channel 2 Settling Reference Count (FDC2114 / FDC2214 only)
0x13	SETTLECOUNT_CH3	0x0000	Channel 3 Settling Reference Count (FDC2114 / FDC2214 only)
0x14	CLOCK_DIVIDERS_CH0	0x0000	Reference divider settings for Channel 0
0x15	CLOCK_DIVIDERS_CH1	0x0000	Reference divider settings for Channel 1
0x16	CLOCK_DIVIDERS_CH2	0x0000	Reference divider settings for Channel 2 (FDC2114 / FDC2214 only)
0x17	CLOCK_DIVIDERS_CH3	0x0000	Reference divider settings for Channel 3 (FDC2114 / FDC2214 only)
0x18	STATUS	0x0000	Device Status Reporting
0x19	STATUS_CONFIG	0x0000	Device Status Reporting Configuration
0x1A	CONFIG	0x2801	Conversion Configuration
0x1B	MUX_CONFIG	0x020F	Channel Multiplexing Configuration
0x1C	RESET_DEV	0x0000	Reset Device
0x1E	DRIVE_CURRENT_CH0	0x0000	Channel 0 sensor current drive configuration
0x1F	DRIVE_CURRENT_CH1	0x0000	Channel 1 sensor current drive configuration
0x20	DRIVE_CURRENT_CH2	0x0000	Channel 2 sensor current drive configuration (FDC2114 / FDC2214 only)
0x21	DRIVE_CURRENT_CH3	0x0000	Channel 3 sensor current drive configuration (FDC2114 / FDC2214 only)
0x7E	MANUFACTURER_ID	0x5449	Manufacturer ID
0x7F	DEVICE_ID	0x3054	Device ID (FDC2112, FDC2114 only)
		0x3055	Device ID (FDC2212, FDC2214 only)

7.6.2 Address 0x00, DATA_CH0
Figure 19. Address 0x00, DATA_CH0

15	14	13	12	11	10	9	8
RESERVED		CH0_ERR_WD	CH0_ERR_AW	DATA0			
7	6	5	4	3	2	1	0
DATA0							

Table 12. Address 0x00, DATA_CH0 Field Descriptions

Bit	Field	Type	Reset	Description
15:14	RESERVED	R	00	Reserved.
13	CH0_ERR_WD	R	0	Channel 0 Conversion Watchdog Timeout Error Flag. Cleared by reading the bit.
12	CH0_ERR_AW	R	0	Channel 0 Amplitude Warning. Cleared by reading the bit.
11:0	DATA0 (FDC2112 / FDC2114 only)	R	0000 0000 0000	Channel 0 Conversion Result
	DATA0[27:16] (FDC2212 / FDC2214 only)			

7.6.3 Address 0x01, DATA_LSB_CH0 (FDC2212 / FDC2214 only)
Figure 20. Address 0x01, DATA_LSB_CH0

15	14	13	12	11	10	9	8
DATA0							
7	6	5	4	3	2	1	0
DATA0							

Table 13. Address 0x01, DATA_CH0 Field Descriptions

Bit	Field	Type	Reset	Description
15:0	DATA0[15:0]	R	0000 0000 0000	Channel 0 Conversion Result

7.6.4 Address 0x02, DATA_CH1
Figure 21. Address 0x02, DATA_CH1

15	14	13	12	11	10	9	8
RESERVED		CH1_ERR_WD	CH1_ERR_AW	DATA1			
7	6	5	4	3	2	1	0
DATA1							

Table 14. Address 0x02, DATA_CH1 Field Descriptions

Bit	Field	Type	Reset	Description
15:14	RESERVED	R	00	Reserved.
13	CH1_ERR_WD	R	0	Channel 1 Conversion Watchdog Timeout Error Flag. Cleared by reading the bit.
12	CH1_ERR_AW	R	0	Channel 1 Amplitude Warning. Cleared by reading the bit.
11:0	DATA1 (FDC2112 / FDC2114 only)	R	0000 0000 0000	Channel 1 Conversion Result
	DATA1[27:16] (FDC2212 / FDC2214 only)			

7.6.5 Address 0x03, DATA_LSB_CH1 (FDC2212 / FDC2214 only)
Figure 22. Address 0x03, DATA_LSB_CH1

15	14	13	12	11	10	9	8
DATA1							
7	6	5	4	3	2	1	0
DATA1							

Table 15. Address 0x03, DATA_CH1 Field Descriptions

Bit	Field	Type	Reset	Description
15:0	DATA1[15:0]	R	0000 0000 0000	Channel 1 Conversion Result

7.6.6 Address 0x04, DATA_CH2 (FDC2114, FDC2214 only)
Figure 23. Address 0x04, DATA_CH2

15	14	13	12	11	10	9	8
RESERVED		CH2_ERR_WD	CH2_ERR_AW	DATA2			
7	6	5	4	3	2	1	0
DATA2							

Table 16. Address 0x04, DATA_CH2 Field Descriptions

Bit	Field	Type	Reset	Description
15:14	RESERVED	R	00	Reserved.
13	CH2_ERR_WD	R	0	Channel 2 Conversion Watchdog Timeout Error Flag. Cleared by reading the bit.
12	CH2_ERR_AW	R	0	Channel 2 Amplitude Warning. Cleared by reading the bit.
11:0	DATA2 (FDC2112 / FDC2114 only)	R	0000 0000 0000	Channel 2 Conversion Result
	DATA2[27:16] (FDC2212 / FDC2214 only)			

7.6.7 Address 0x05, DATA_LSB_CH2 (FDC2214 only)
Figure 24. Address 0x05, DATA_LSB_CH2

15	14	13	12	11	10	9	8
DATA2							
7	6	5	4	3	2	1	0
DATA2							

Table 17. Address 0x05, DATA_CH2 Field Descriptions

Bit	Field	Type	Reset	Description
15:0	DATA2[15:0]	R	0000 0000 0000	Channel 2 Conversion Result

7.6.8 Address 0x06, DATA_CH3 (FDC2114, FDC2214 only)
Figure 25. Address 0x06, DATA_CH3

15	14	13	12	11	10	9	8
RESERVED		CH3_ERR_WD	CH3_ERR_AW	DATA3			
7	6	5	4	3	2	1	0
DATA3							

Table 18. Address 0x06, DATA_CH3 Field Descriptions

Bit	Field	Type	Reset	Description
15:14	RESERVED	R	00	Reserved.
13	CH3_ERR_WD	R	0	Channel 3 Conversion Watchdog Timeout Error Flag. Cleared by reading the bit.
12	CH3_ERR_AW	R	0	Channel 3 Amplitude Warning. Cleared by reading the bit.
11:0	DATA3 (FDC2112 / FDC2114 only)	R	0000 0000 0000	Channel 3 Conversion Result
	DATA3[27:16] (FDC2212 / FDC2214 only)			

7.6.9 Address 0x07, DATA_LSB_CH3 (FDC2214 only)
Figure 26. Address 0x07, DATA_LSB_CH3

15	14	13	12	11	10	9	8
DATA3							
7	6	5	4	3	2	1	0
DATA3							

Table 19. Address 0x07, DATA_CH3 Field Descriptions

Bit	Field	Type	Reset	Description
15:0	DATA3[15:0]	R	0000 0000 0000	Channel 3 Conversion Result

7.6.10 Address 0x08, RCOUNT_CH0
Figure 27. Address 0x08, RCOUNT_CH0

15	14	13	12	11	10	9	8
CH0_RCOUNT							
7	6	5	4	3	2	1	0
CH0_RCOUNT							

Table 20. Address 0x08, RCOUNT_CH0 Field Descriptions

Bit	Field	Type	Reset	Description
15:0	CH0_RCOUNT	R/W	0000 0000 1000 0000	Channel 0 Reference Count Conversion Interval Time 0x0000-0x00FF: Reserved 0x0100-0xFFFF: Conversion Time (t_{CO}) = $(CH0_RCOUNT \times 16) / f_{REF0}$

7.6.11 Address 0x09, RCOUNT_CH1
Figure 28. Address 0x09, RCOUNT_CH1

15	14	13	12	11	10	9	8
RCOUNT_CH1							
7	6	5	4	3	2	1	0
RCOUNT_CH1							

Table 21. Address 0x09, RCOUNT_CH1 Field Descriptions

Bit	Field	Type	Reset	Description
15:0	RCOUNT_CH1	R/W	0000 0000 1000 0000	Channel 1 Reference Count Conversion Interval Time 0x0000-0x00FF: Reserved 0x0100-0xFFFF: Conversion Time (t_{C1})= (RCOUNT_CH1*16)/f _{REF1}

7.6.12 Address 0x0A, RCOUNT_CH2 (FDC2114, FDC2214 only)
Figure 29. Address 0x0A, RCOUNT_CH2

15	14	13	12	11	10	9	8
RCOUNT_CH2							
7	6	5	4	3	2	1	0
RCOUNT_CH2							

Table 22. Address 0x0A, RCOUNT_CH2 Field Descriptions

Bit	Field	Type	Reset	Description
15:0	RCOUNT_CH2	R/W	0000 0000 1000 0000	Channel 2 Reference Count Conversion Interval Time 0x0000-0x00FF: Reserved 0x0100-0xFFFF: Conversion Time (t_{C2})= (RCOUNT_CH2*16)/f _{REF2}

7.6.13 Address 0x0B, RCOUNT_CH3 (FDC2114, FDC2214 only)
Figure 30. Address 0x0B, RCOUNT_CH3

15	14	13	12	11	10	9	8
RCOUNT_CH3							
7	6	5	4	3	2	1	0
RCOUNT_CH3							

Table 23. Address 0x0B, RCOUNT_CH3 Field Descriptions

Bit	Field	Type	Reset	Description
15:0	RCOUNT_CH3	R/W	0000 0000 1000 0000	Channel 3 Reference Count Conversion Interval Time 0x0000-0x00FF: Reserved 0x0100-0xFFFF: Conversion Time (t_{C3})= (RCOUNT_CH3*16)/f _{REF3}

7.6.14 Address 0x0C, OFFSET_CH0 (FDC21112 / FDC2114 only)
Figure 31. Address 0x0C, CH0_OFFSET

15	14	13	12	11	10	9	8
CH0_OFFSET							
7	6	5	4	3	2	1	0
CH0_OFFSET							

Table 24. CH0_OFFSET Field Descriptions

Bit	Field	Type	Reset	Description
15:0	CH0_OFFSET	R/W	0000 0000 0000 0000	Channel 0 Conversion Offset. $f_{\text{OFFSET}_0} = (\text{CH0_OFFSET}/2^{16}) \cdot f_{\text{REF0}}$

7.6.15 Address 0x0D, OFFSET_CH1 (FDC21112 / FDC2114 only)
Figure 32. Address 0x0D, OFFSET_CH1

15	14	13	12	11	10	9	8
CH1_OFFSET							
7	6	5	4	3	2	1	0
CH1_OFFSET							

Table 25. Address 0x0D, OFFSET_CH1 Field Descriptions

Bit	Field	Type	Reset	Description
15:0	CH1_OFFSET	R/W	0000 0000 0000 0000	Channel 1 Conversion Offset. $f_{\text{OFFSET}_1} = (\text{CH1_OFFSET}/2^{16}) \cdot f_{\text{REF1}}$

7.6.16 Address 0x0E, OFFSET_CH2 (FDC2114 only)
Figure 33. Address 0x0E, OFFSET_CH2

15	14	13	12	11	10	9	8
CH2_OFFSET							
7	6	5	4	3	2	1	0
CH2_OFFSET							

Table 26. Address 0x0E, OFFSET_CH2 Field Descriptions

Bit	Field	Type	Reset	Description
15:0	CH2_OFFSET	R/W	0000 0000 0000 0000	Channel 2 Conversion Offset. $f_{\text{OFFSET}_2} = (\text{CH2_OFFSET}/2^{16}) \cdot f_{\text{REF2}}$

7.6.17 Address 0x0F, OFFSET_CH3 (FDC2114 only)
Figure 34. Address 0x0F, OFFSET_CH3

15	14	13	12	11	10	9	8
CH3_OFFSET							
7	6	5	4	3	2	1	0
CH3_OFFSET							

Table 27. Address 0x0F, OFFSET_CH3 Field Descriptions

Bit	Field	Type	Reset	Description
15:0	CH3_OFFSET	R/W	0000 0000 0000 0000	Channel 3 Conversion Offset. $f_{\text{OFFSET}_3} = (\text{CH3_OFFSET}/2^{16}) \cdot f_{\text{REF3}}$

7.6.18 Address 0x10, SETTLECOUNT_CH0
Figure 35. Address 0x10, SETTLECOUNT_CH0

15	14	13	12	11	10	9	8
CH0_SETTLECOUNT							
7	6	5	4	3	2	1	0
CH0_SETTLECOUNT							

Table 28. Address 0x11, SETTLECOUNT_CH0 Field Descriptions

Bit	Field	Type	Reset	Description
15:0	CH0_SETTLECOUNT	R/W	0000 0000 0000 0000	Channel 0 Conversion Settling The FDC will use this settling time to allow the LC sensor to stabilize before initiation of a conversion on Channel 0. If the amplitude has not settled prior to the conversion start, an Amplitude warning will be generated if reporting of this type of warning is enabled. 0x0000: Settle Time (t_{S0})= $32 \div f_{\text{REF0}}$ 0x0001: Settle Time (t_{S0})= $32 \div f_{\text{REF0}}$ 0x0002 - 0xFFFF: Settle Time (t_{S0})= $(\text{CH0_SETTLECOUNT} \times 16) \div f_{\text{REF0}}$

7.6.19 Address 0x11, SETTLECOUNT_CH1
Figure 36. Address 0x11, SETTLECOUNT_CH1

15	14	13	12	11	10	9	8
CH1_SETTLECOUNT							
7	6	5	4	3	2	1	0
CH1_SETTLECOUNT							

Table 29. Address 0x12, SETTLECOUNT_CH1 Field Descriptions

Bit	Field	Type	Reset	Description
15:0	CH1_SETTLECOUNT	R/W	0000 0000 0000 0000	Channel 1 Conversion Settling The FDC will use this settling time to allow the LC sensor to stabilize before initiation of a conversion on a Channel 1. If the amplitude has not settled prior to the conversion start, an Amplitude warning will be generated if reporting of this type of warning is enabled. 0x0000: Settle Time (t_{S1})= $32 \div f_{\text{REF1}}$ 0x0001: Settle Time (t_{S1})= $32 \div f_{\text{REF1}}$ 0x0002 - 0xFFFF: Settle Time (t_{S1})= $(\text{CH1_SETTLECOUNT} \times 16) \div f_{\text{REF1}}$

7.6.20 Address 0x12, SETTLECOUNT_CH2 (FDC2114, FDC2214 only)
Figure 37. Address 0x12, SETTLECOUNT_CH2

15	14	13	12	11	10	9	8
CH2_SETTLECOUNT							
7	6	5	4	3	2	1	0
CH2_SETTLECOUNT							

Table 30. Address 0x12, SETTLECOUNT_CH2 Field Descriptions

Bit	Field	Type	Reset	Description
15:0	CH2_SETTLECOUNT	R/W	0000 0000 0000 0000	Channel 2 Conversion Settling The FDC will use this settling time to allow the LC sensor to stabilize before initiation of a conversion on Channel 2. If the amplitude has not settled prior to the conversion start, an Amplitude warning will be generated if reporting of this type of warning is enabled. 0x0000: Settle Time (t_{S2}) = $32 \div f_{REF2}$ 0x0001: Settle Time (t_{S2}) = $32 \div f_{REF2}$ 0x0002 - 0xFFFF: Settle Time (t_{S2}) = (CH2_SETTLECOUNT*16) $\div f_{REF2}$

7.6.21 Address 0x13, SETTLECOUNT_CH3 (FDC2114, FDC2214 only)
Figure 38. Address 0x13, SETTLECOUNT_CH3

15	14	13	12	11	10	9	8
CH3_SETTLECOUNT							
7	6	5	4	3	2	1	0
CH3_SETTLECOUNT							

Table 31. Address 0x13, SETTLECOUNT_CH3 Field Descriptions

Bit	Field	Type	Reset	Description
15:0	CH3_SETTLECOUNT	R/W	0000 0000 0000 0000	Channel 3 Conversion Settling The FDC will use this settling time to allow the LC sensor to stabilize before initiation of a conversion on Channel 3. If the amplitude has not settled prior to the conversion start, an Amplitude warning will be generated if reporting of this type of warning is enabled 0x0000: Settle Time (t_{S3}) = $32 \div f_{REF3}$ 0x0001: Settle Time (t_{S3}) = $32 \div f_{REF3}$ 0x0002 - 0xFFFF: Settle Time (t_{S3}) = (CH3_SETTLECOUNT*16) $\div f_{REF3}$

7.6.22 Address 0x14, CLOCK_DIVIDERS_CH0
Figure 39. Address 0x14, CLOCK_DIVIDERS_CH0

15	14	13	12	11	10	9	8
RESERVED		CH0_FIN_SEL		RESERVED		CH0_FREF_DIVIDER	
7	6	5	4	3	2	1	0
CH0_FREF_DIVIDER							

Table 32. Address 0x14, CLOCK_DIVIDERS_CH0 Field Descriptions

Bit	Field	Type	Reset	Description
15:14	RESERVED	R/W	00	Reserved. Set to b00.
13:12	CH0_FIN_SEL	R/W	00	Channel 0 Sensor frequency select for differential sensor configuration: b01: divide by 1. Choose for sensor frequencies between 0.01 MHz and 8.75 MHz b10: divide by 2. Choose for sensor frequencies between 5 MHz and 10 MHz for single-ended sensor configuration: b10: divide by 2. Choose for sensor frequencies between 0.01 MHz and 10 MHz
11:10	RESERVED	R/W	00	Reserved. Set to b00.
9:0	CH0_FREF_DIVIDER	R/W	00 0000 0000	Channel 0 Reference Divider Sets the divider for Channel 0 reference. Use this to scale the maximum conversion frequency. b00'0000'0000: Reserved. Do not use. $CH0_FREF_DIVIDER \geq b00'0000'0001: f_{REF0} = f_{CLK}/CH0_FREF_DIVIDER$

7.6.23 Address 0x15, CLOCK_DIVIDERS_CH1
Figure 40. Address 0x15, CLOCK_DIVIDERS_CH1

15	14	13	12	11	10	9	8
RESERVED		CH1_FIN_SEL		RESERVED		CH1_FREF_DIVIDER	
7	6	5	4	3	2	1	0
CH1_FREF_DIVIDER							

Table 33. Address 0x15, CLOCK_DIVIDERS_CH1 Field Descriptions

Bit	Field	Type	Reset	Description
15:14	RESERVED	R/W	00	Reserved. Set to b00.
13:12	CH1_FIN_SEL	R/W	0000	Channel 1 Sensor frequency select for differential sensor configuration: b01: divide by 1. Choose for sensor frequencies between 0.01 MHz and 8.75 MHz b10: divide by 2. Choose for sensor frequencies between 5 MHz and 10 MHz for single-ended sensor configuration: b10: divide by 2. Choose for sensor frequencies between 0.01 MHz and 10 MHz
11:10	RESERVED	R/W	00	Reserved. Set to b00.
9:0	CH1_FREF_DIVIDER	R/W	00 0000 0000	Channel 1 Reference Divider Sets the divider for Channel 1 reference. Use this to scale the maximum conversion frequency. b00'0000'0000: Reserved. Do not use. $CH1_FREF_DIVIDER \geq b00'0000'0001: f_{REF1} = f_{CLK}/CH1_FREF_DIVIDER$

7.6.24 Address 0x16, CLOCK_DIVIDERS_CH2 (FDC2114, FDC2214 only)
Figure 41. Address 0x16, CLOCK_DIVIDERS_CH2

15	14	13	12	11	10	9	8
RESERVED		CH2_FIN_SEL		RESERVED		CH2_FREF_DIVIDER	
7	6	5	4	3	2	1	0
CH2_FREF_DIVIDER							

Table 34. Address 0x16, CLOCK_DIVIDERS_CH2 Field Descriptions

Bit	Field	Type	Reset	Description
15:14	RESERVED	R/W	00	Reserved. Set to b00.
13:12	CH2_FIN_SEL	R/W	0000	Channel 2 Sensor frequency select for differential sensor configuration: b01: divide by 1. Choose for sensor frequencies between 0.01 MHz and 8.75 MHz b10: divide by 2. Choose for sensor frequencies between 5 MHz and 10 MHz for single-ended sensor configuration: b10: divide by 2. Choose for sensor frequencies between 0.01 MHz and 10 MHz
11:10	RESERVED	R/W	00	Reserved. Set to b00.
9:0	CH2_FREF_DIVIDER	R/W	00 0000 0000	Channel 2 Reference Divider Sets the divider for Channel 2 reference. Use this to scale the maximum conversion frequency. b00'0000'0000: Reserved. Do not use. CH2_FREF_DIVIDER ≥ b00'0000'0001: $f_{REF2} = f_{CLK}/CH2_FREF_DIVIDER$

7.6.25 Address 0x17, CLOCK_DIVIDERS_CH3 (FDC2114, FDC2214 only)
Figure 42. Address 0x17, CLOCK_DIVIDERS_CH3

15	14	13	12	11	10	9	8
RESERVED		CH3_FIN_SEL		RESERVED		CH3_FREF_DIVIDER	
7	6	5	4	3	2	1	0
CH3_FREF_DIVIDER							

Table 35. Address 0x17, CLOCK_DIVIDERS_CH3

Bit	Field	Type	Reset	Description
15:14	RESERVED	R/W	00	Reserved. Set to b00.
13:12	CH3_FIN_SEL	R/W	0000	Channel 3 Sensor frequency select for differential sensor configuration: b01: divide by 1. Choose for sensor frequencies between 0.01 MHz and 8.75 MHz b10: divide by 2. Choose for sensor frequencies between 5 MHz and 10 MHz for single-ended sensor configuration: b10: divide by 2. Choose for sensor frequencies between 0.01 MHz and 10 MHz
11:10	RESERVED	R/W	00	Reserved. Set to b00.
9:0	CH3_FREF_DIVIDER	R/W	00 0000 0000	Channel 3 Reference Divider Sets the divider for Channel 3 reference. Use this to scale the maximum conversion frequency. b00'0000'0000: reserved CH3_FREF_DIVIDER ≥ b00'0000'0001: $f_{REF3} = f_{CLK}/CH3_FREF_DIVIDER$

7.6.26 Address 0x18, STATUS
Figure 43. Address 0x18, STATUS

15	14	13	12	11	10	9	8
ERR_CHAN		RESERVED		ERR_WD	RESERVED		
7	6	5	4	3	2	1	0
RESERVED	DRDY	RESERVED		CH0_UNREA D CONV	CH1_ UNREADCONV	CH2_ UNREADCONV	CH3_ UNREADCONV

Table 36. Address 0x18, STATUS Field Descriptions

Bit	Field	Type	Reset	Description
15:14	ERR_CHAN	R	00	Error Channel Indicates which channel has generated a Flag or Error. Once flagged, any reported error is latched and maintained until either the STATUS register or the DATA_CHx register corresponding to the Error Channel is read. b00: Channel 0 is source of flag or error. b01: Channel 1 is source of flag or error. b10: Channel 2 is source of flag or error (FDC2114, FDC2214 only). b11: Channel 3 is source of flag or error (FDC2114, FDC2214 only).
13:12	RESERVED	R	00	Reserved
11	ERR_WD	R	0	Watchdog Timeout Error b0: No Watchdog Timeout error was recorded since the last read of the STATUS register. b1: An active channel has generated a Watchdog Timeout error. Refer to STATUS.ERR_CHAN field to determine which channel is the source of this error.
10	ERR_AHW	R	0	Amplitude High Warning b0: No Amplitude High warning was recorded since the last read of the STATUS register. b1: An active channel has generated an Amplitude High warning. Refer to STATUS.ERR_CHAN field to determine which channel is the source of this warning.
9	ERR_ALW	R	0	Amplitude Low Warning b0: No Amplitude Low warning was recorded since the last read of the STATUS register. b1: An active channel has generated an Amplitude Low warning. Refer to STATUS.ERR_CHAN field to determine which channel is the source of this warning.
8:7	RESERVED	R	00	Reserved
6	DRDY	R	0	Data Ready Flag. b0: No new conversion result was recorded in the STATUS register. b1: A new conversion result is ready. When in Single Channel Conversion, this indicates a single conversion is available. When in sequential mode, this indicates that a new conversion result for all active channels is now available.
3	CH0_UNREADCONV	R	0	Channel 0 Unread Conversion b0: No unread conversion is present for Channel 0. b1: An unread conversion is present for Channel 0. Read Register DATA_CH0 to retrieve conversion results.
2	CH1_UNREADCONV	R	0	Channel 1 Unread Conversion b0: No unread conversion is present for Channel 1. b1: An unread conversion is present for Channel 1. Read Register DATA_CH1 to retrieve conversion results.
1	CH2_UNREADCONV	R	0	Channel 2 Unread Conversion b0: No unread conversion is present for Channel 2. b1: An unread conversion is present for Channel 2. Read Register DATA_CH2 to retrieve conversion results (FDC2114, FDC2214 only)
0	CH3_UNREADCONV	R	0	Channel 3 Unread Conversion b0: No unread conversion is present for Channel 3. b1: An unread conversion is present for Channel 3. Read Register DATA_CH3 to retrieve conversion results (FDC2114, FDC2214 only)

7.6.27 Address 0x19, ERROR_CONFIG
Figure 44. Address 0x19, ERROR_CONFIG

15	14	13	12	11	10	9	8
RESERVED		WD_ ERR2OUT	AH_WARN2OU T	AL_WARN2OU T	RESERVED		
7	6	5	4	3	2	1	0
RESERVED		WD_ERR2INT	RESERVED				DRDY_2INT

Table 37. Address 0x19, ERROR_CONFIG

Bit	Field	Type	Reset	Description
15:14	RESERVED	R/W	00	Reserved (set to b000)
13	WD_ERR2OUT	R/W	0	Watchdog Timeout Error to Output Register b0: Do not report Watchdog Timeout errors in the DATA_CHx registers. b1: Report Watchdog Timeout errors in the DATA_CHx.CHx_ERR_WD register field corresponding to the channel that generated the error.
12	AH_WARN2OUT	R/W	0	Amplitude High Warning to Output Register b0: Do not report Amplitude High warnings in the DATA_CHx registers. b1: Report Amplitude High warnings in the DATA_CHx.CHx_ERR_AW register field corresponding to the channel that generated the warning.
11	AL_WARN2OUT	R/W	0	Amplitude Low Warning to Output Register b0: Do not report Amplitude Low warnings in the DATA_CHx registers. b1: Report Amplitude High warnings in the DATA_CHx.CHx_ERR_AW register field corresponding to the channel that generated the warning.
10:6	RESERVED	R/W	0 0000	Reserved (set to b0 0000)
5	WD_ERR2INT	R/W	0	Watchdog Timeout Error to INTB b0: Do not report Under-range errors by asserting INTB pin and STATUS register. b1: Report Watchdog Timeout errors by asserting INTB pin and updating STATUS.ERR_WD register field.
4:1	Reserved	R/W	0000	Reserved (set to b000)
0	DRDY_2INT	R/W	0	Data Ready Flag to INTB b0: Do not report Data Ready Flag by asserting INTB pin and STATUS register. b1: Report Data Ready Flag by asserting INTB pin and updating STATUS.DRDY register field.

7.6.28 Address 0x1A, CONFIG
Figure 45. Address 0x1A, CONFIG

15		14		13		12		11		10		9		8	
ACTIVE_CHAN			SLEEP_MODE _EN		RESERVED		SENSOR_ACTI VATE_SEL		RESERVED		REF_CLK_SR C		RESERVED		
7		6		5		4		3		2		1		0	
INTB_DIS		HIGH_CURRE NT_DRV		RESERVED											

Table 38. Address 0x1A, CONFIG Field Descriptions

Bit	Field	Type	Reset	Description
15:14	ACTIVE_CHAN	R/W	00	Active channel selection Selects channel for continuous conversions when MUX_CONFIG.SEQUENTIAL is 0. b00: Perform continuous conversions on Channel 0 b01: Perform continuous conversions on Channel 1 b10: Perform continuous conversions on Channel 2 (FDC2114, FDC2214 only) b11: Perform continuous conversions on Channel 3 (FDC2114, FDC2214 only)
13	SLEEP_MODE_EN	R/W	1	Sleep mode enable Enter or exit low power sleep mode. b0: Device is active. b1: Device is in sleep mode.
12	RESERVED	R/W	0	Reserved. Set to b1.
11	SENSOR_ACTIVATE_SEL	R/W	1	Sensor activation mode selection. Set the mode for sensor initialization. b0: Full current activation mode – the FDC will drive maximum sensor current for a shorter sensor activation time. b1: Low power activation mode – the FDC uses the value programmed in DRIVE_CURRENT_CHx during sensor activation to minimize power consumption.
10	RESERVED	R/W	0	Reserved. Set to b1.
9	REF_CLK_SRC	R/W	0	Select Reference Frequency Source b0: Use Internal oscillator as reference frequency b1: Reference frequency is provided from CLKIN pin.
8	RESERVED	R/W	0	Reserved. Set to b0.
7	INTB_DIS	R/W	0	INTB Disable b0: INTB pin is asserted when status register updates. b1: INTB pin is not asserted when status register updates
6	HIGH_CURRENT_DRV	R/W	0	High Current Sensor Drive b0: The FDC drives all channels with normal sensor current (1.5 mA maximum). b1: The FDC drives channel 0 with current >1.5 mA. This mode is not supported if AUTOSCAN_EN = b1 (multi-channel mode)
5:0	RESERVED	R/W	00 0001	Reserved Set to b00'0001

7.6.29 Address 0x1B, MUX_CONFIG
Figure 46. Address 0x1B, MUX_CONFIG

15	14	13	12	11	10	9	8
AUTOSCAN_EN		RR_SEQUENCE		RESERVED			
7	6	5	4	3	2	1	0
RESERVED					DEGLITCH		

Table 39. Address 0x1B, MUX_CONFIG Field Descriptions

Bit	Field	Type	Reset	Description
15	AUTOSCAN_EN	R/W	0	Auto-Scan mode enable b0: Continuous conversion on the single channel selected by CONFIG.ACTIVE_CHAN register field. b1: Auto-Scan conversions as selected by MUX_CONFIG.RR_SEQUENCE register field.
14:13	RR_SEQUENCE	R/W	00	Auto-Scan sequence configuration Configure multiplexing channel sequence. The FDC performs a single conversion on each channel in the sequence selected, and then restart the sequence continuously. b00: Ch0, Ch1 b01: Ch0, Ch1, Ch2 (FDC2114, FDC2214 only) b10: Ch0, Ch1, Ch2, Ch3 (FDC2114, FDC2214 only) b11: Ch0, Ch1
12:3	RESERVED	R/W	00 0100 0001	Reserved. Must be set to 00 0100 0001
2:0	DEGLITCH	R/W	111	Input deglitch filter bandwidth. Select the lowest setting that exceeds the oscillation tank oscillation frequency. b001: 1 MHz b100: 3.3 MHz b101: 10 MHz b111: 33 MHz

7.6.30 Address 0x1C, RESET_DEV
Figure 47. Address 0x1C, RESET_DEV

15	14	13	12	11	10	9	8
RESET_DEV		RESERVED			OUTPUT_GAIN		RESERVED
7	6	5	4	3	2	1	0
RESERVED							

Table 40. Address 0x1C, RESET_DEV Field Descriptions

Bit	Field	Type	Reset	Description
15	RESET_DEV	R/W	0	Device Reset Write b1 to reset the device. Will always readback 0.
14:11	RESERVED	R/W	0000	Reserved. Set to b0000
10:9	OUTPUT_GAIN	R/W	00	Output gain control (FDC2112, FDC2114 only) 00: Gain = 1 (0 bits shift) 01: Gain = 4 (2 bits shift) 10: Gain = 8 (3 bits shift) 11: Gain = 16 (4 bits shift)
8:0	RESERVED	R/W	0 0000 0000	Reserved, Set to b0 0000 0000

7.6.31 Address 0x1E, DRIVE_CURRENT_CH0
Figure 48. Address 0x1E, DRIVE_CURRENT_CH0

15	14	13	12	11	10	9	8
CH0_IDRIVE					RESERVED		
7	6	5	4	3	2	1	0
RESERVED							

Table 41. Address 0x1E, DRIVE_CURRENT_CH0 Field Descriptions

Bit	Field	Type	Reset	Description
15:11	CH0_IDRIVE	R/W	0000 0	Channel 0 Sensor drive current This field defines the Drive Current used during the settling + conversion time of Channel 0 sensor clock. Set such that $1.2V \leq$ sensor oscillation amplitude (pk) $\leq 1.8V$ 00000: 0.016 mA 00001: 0.018 mA 00010: 0.021 mA 00011: 0.025 mA 00100: 0.028 mA 00101: 0.033 mA 00110: 0.038 mA 00111: 0.044 mA 01000: 0.052 mA 01001: 0.060 mA 01010: 0.069 mA 01011: 0.081 mA 01100: 0.093 mA 01101: 0.108 mA 01110: 0.126 mA 01111: 0.146 mA 10000: 0.169 mA 10001: 0.196 mA 10010: 0.228 mA 10011: 0.264 mA 10100: 0.307 mA 10101: 0.356 mA 10110: 0.413 mA 10111: 0.479 mA 11000: 0.555 mA 11001: 0.644 mA 11010: 0.747 mA 11011: 0.867 mA 11100: 1.006 mA 11101: 1.167 mA 11110: 1.354 mA 11111: 1.571 mA
10:0	RESERVED	–	000 0000 0000	Reserved

7.6.32 Address 0x1F, DRIVE_CURRENT_CH1
Figure 49. Address 0x1F, DRIVE_CURRENT_CH1

15	14	13	12	11	10	9	8
CH1_IDRIVE						RESERVED	
7	6	5	4	3	2	1	0
RESERVED							

Table 42. Address 0x1F, DRIVE_CURRENT_CH1 Field Descriptions

Bit	Field	Type	Reset	Description
15:11	CH1_IDRIVE	R/W	0000 0	Channel 1 Sensor drive current This field defines the drive current used during the settling + conversion time of Channel 1 sensor clock. Set such that $1.2\text{ V} \leq \text{sensor oscillation amplitude (pk)} \leq 1.8\text{ V}$ 00000: 0.016 mA 00001: 0.018 mA 00010: 0.021 mA ... 11111: 1.571 mA
10:0	RESERVED	-	000 0000 0000	Reserved

7.6.33 Address 0x20, DRIVE_CURRENT_CH2 (FDC2114 / FDC2214 only)
Figure 50. Address 0x20, DRIVE_CURRENT_CH2

15	14	13	12	11	10	9	8
CH2_IDRIVE						RESERVED	
7	6	5	4	3	2	1	0
RESERVED							

Table 43. Address 0x20, DRIVE_CURRENT_CH2 Field Descriptions

Bit	Field	Type	Reset	Description
15:11	CH2_IDRIVE	R/W	0000 0	Channel 2 Sensor drive current This field defines the drive current to be used during the settling + conversion time of Channel 2 sensor clock. Set such that $1.2\text{ V} \leq \text{sensor oscillation amplitude (pk)} \leq 1.8\text{ V}$ 00000: 0.016 mA 00001: 0.018 mA 00010: 0.021 mA ... 11111: 1.571 mA
10:0	RESERVED	-	000 0000 0000	Reserved

7.6.34 Address 0x21, DRIVE_CURRENT_CH3 (FDC2114 / FDC2214 only)
Figure 51. Address 0x21, DRIVE_CURRENT_CH3

15	14	13	12	11	10	9	8
CH3_IDRIVE					RESERVED		
7	6	5	4	3	2	1	0
RESERVED							

Table 44. DRIVE_CURRENT_CH3 Field Descriptions

Bit	Field	Type	Reset	Description
15:11	CH3_IDRIVE	R/W	0000 0	Channel 3 Sensor drive current This field defines the drive current to be used during the settling + conversion time of Channel 3 sensor clock. Set such that $1.2V \leq \text{sensor oscillation amplitude (pk)} \leq 1.8 V$ 00000: 0.016 mA 00001: 0.018 mA 00010: 0.021 mA ... 11111: 1.571 mA
10:0	RESERVED	–	000 0000 0000	Reserved

7.6.35 Address 0x7E, MANUFACTURER_ID
Figure 52. Address 0x7E, MANUFACTURER_ID

15	14	13	12	11	10	9	8
MANUFACTURER_ID							
7	6	5	4	3	2	1	0
MANUFACTURER_ID							

Table 45. Address 0x7E, MANUFACTURER_ID Field Descriptions

Bit	Field	Type	Reset	Description
15:0	MANUFACTURER_ID	R	0101 0100 0100 1001	Manufacturer ID = 0x5449

7.6.36 Address 0x7F, DEVICE_ID
Figure 53. Address 0x7F, DEVICE_ID

7	6	5	4	3	2	1	0
DEVICE_ID							

Table 46. Address 0x7F, DEVICE_ID Field Descriptions

Bit	Field	Type	Reset	Description
7:0	DEVICE_ID	R	0011 0000 0101 0100	Device ID 0x3054 (FDC2112, FDC2114 only) 0x3055 (FDC2212, FDC2214 only)

8 Application and Implementation

NOTE

Information in the following applications sections is not part of the TI component specification, and TI does not warrant its accuracy or completeness. TI's customers are responsible for determining suitability of components for their purposes. Customers should validate and test their design implementation to confirm system functionality.

8.1 Application Information

8.1.1 Sensor Configuration

The FDC supports two sensor configurations. Both configurations use an LC tank to set the frequency of oscillation. A typical choice is an 18- μ H shielded SMD inductor in parallel with a 33-pF capacitor, which result in a 6.5-MHz oscillation frequency. In the single-ended configuration in [Figure 54](#), a conductive plate is connected to IN0A. Together with a target object, the conductive plate forms a variable capacitor.

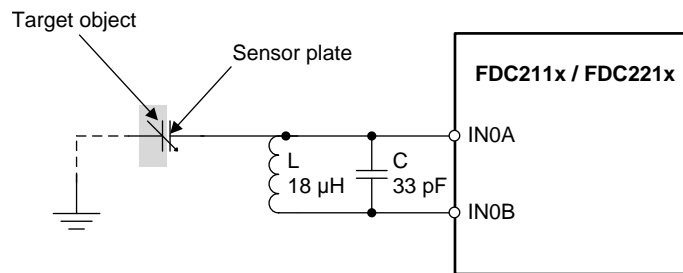

Copyright © 2016, Texas Instruments Incorporated

Figure 54. Single-ended Sensor Configuration

In the differential sensor configuration in [Figure 55](#), one conductive plate is connected to IN0A, and a second conductive plate is connected to IN0B. Together, they form a variable capacitor. When using an single-ended sensor configuration, set CHx_FIN_SEL to b10 (divide by 2).

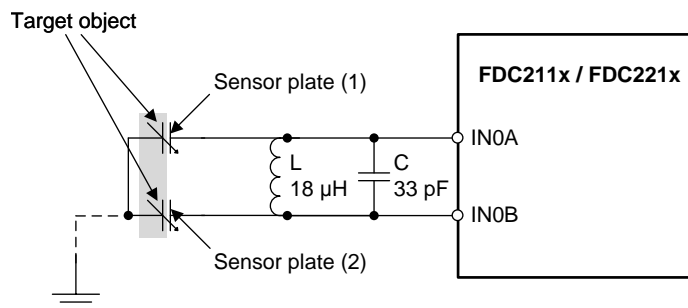

Copyright © 2016, Texas Instruments Incorporated

Figure 55. Differential Sensor Configuration

The single-ended configuration allows higher sensing range than the differential configuration for a given total sensor plate area. In applications in which high sensitivity at close proximity is desired, the differential configuration performs better than the single-ended configuration.

Application Information (continued)

8.1.2 Shield

in order to minimize interference from external objects, some applications require an additional plate which acts as a shield. The shield can either be:

- actively driven shield: The shield is a buffered signal of the INxA pin. The signal is buffered by an external amplifier with a gain of 1.
- passive shield: The shield is connected to GND. Adding a passive shield decreases sensitivity of the sensor, but is dependent on the distance between the sensing plate and the shield. The distance between the sensing plate and the shield should be adjusted to achieve the required sensitivity

8.1.3 Power-Cycled Applications

For applications which do not require high sample rates or maximum conversion resolution, the total active conversion time of the FDC can be minimized to reduce power consumption. This can be done by either by using sleep mode or shutdown mode during times in which conversions are not required (see [Device Functional Modes](#)).

As an example, for an application which only needs 10 samples per second with a resolution of 16 bits can utilize the low-power modes. The sensor requires SETTLECOUNT = 16 and IDRIVE of 01111b (0.146 mA). Given FREF = 40 MHz and RCOUNT = 4096 will provide the resolution required. This corresponds to $4096 \times 16 \times 10 / 40 \text{ MHz} \rightarrow 16.4 \text{ ms}$ of active conversion time per second. Start-up time and channel switch delay account for an additional 0.34 ms. For the remainder of the time, the device can be in sleep mode: Therefore, the average current is $19.4 \text{ ms} \times 3.6 \text{ mA}$ active current + 980.6 ms of $35 \mu\text{A}$ of sleep current, which is approximately $104.6 \mu\text{A}$ of average supply current. Sleep mode retains register settings and therefore requires less I2C writes to wake up the FDC than shutdown mode.

Greater current savings can be realized by use of shutdown mode during inactive periods. In shutdown mode, device configuration is not retained, so the device must be configured for each sample. For this example, configuring each sample takes approximately 1.2 ms ($13 \text{ registers} \times 92.5 \mu\text{s}$ per register). The total active time is 20.6 ms. The average current is $20 \text{ ms} \times 3.6 \text{ mA}$ active current + $980 \text{ ms} \times 2 \mu\text{A}$ of shutdown current, which is approximately $75 \mu\text{A}$ of average supply current.

For further information on power-cycled applications, refer to [Power Reduction Techniques for the FDC2214/2212/2114/2112 in Capacitive Sensing Applications](#).

8.1.4 Inductor Self-Resonant Frequency

Every inductor has a distributed parasitic capacitance, which is dependent on construction and geometry. At the self-resonant frequency (SRF), the reactance of the inductor cancels the reactance of the parasitic capacitance. Above the SRF, the inductor will electrically appear to be a capacitor. Because the parasitic capacitance is not well-controlled or stable, TI recommends: $f_{\text{SENSOR}} < 0.8 \times f_{\text{SR}}$.

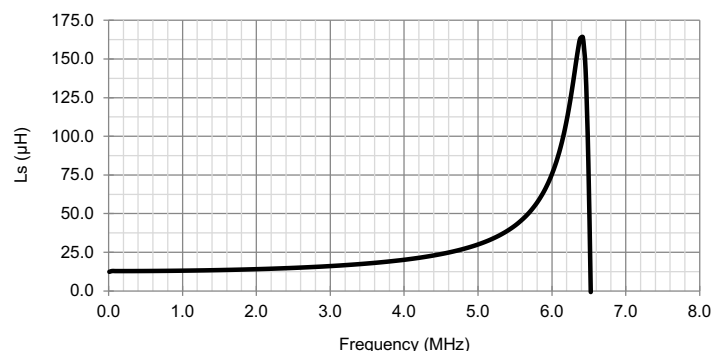

Figure 56. Example Coil Inductance vs Frequency

The example inductor in [Figure 56](#), has a SRF at 6.38 MHz; therefore, the inductor must not be operated above $0.8 \times 6.38 \text{ MHz}$, or 5.1 MHz.

Application Information (continued)

8.1.5 Application Curves for Proximity Sensing

Common test conditions (unless specified otherwise): Sensor capacitor: 1 layer, 20.9 × 13.9 mm, Bourns CMH322522-180KL sensor inductor with L=18 μH and 33 pF 1% COG/NP0 Target: Grounded aluminum plate (176 × 123 mm), Channel = Channel 0 (continuous mode) CLKIN = 40 MHz, CHx_FIN_SEL = b10, CHx_FREF_DIVIDER = b00 0000 0001 CH0_RCOUNT = 0xFFFF, SETTLECOUNT_CH0 = 0x0100, DRIVE_CURRENT_CH0 = 0x7800

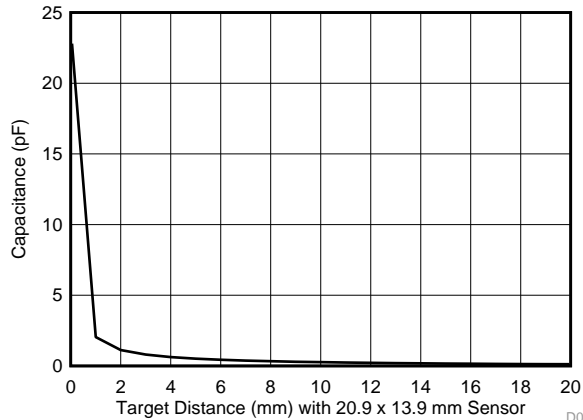

Figure 57. FDC2212 / FDC2214: Capacitance vs Target Distance (0 to 20 mm)

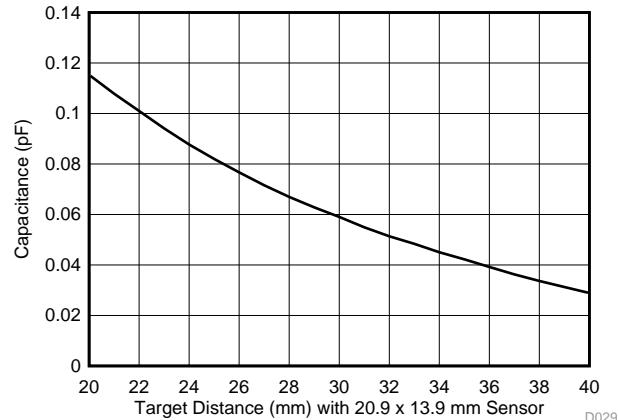

Figure 58. FDC2112 / FDC2114: Capacitance vs Target Distance (20 to 40 mm)

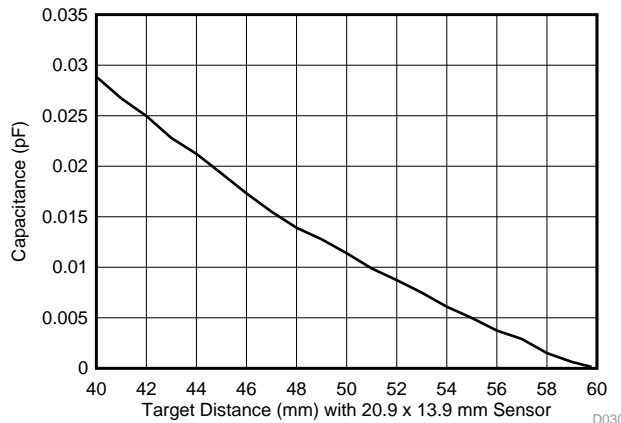

Figure 59. FDC2212 / FDC2214: Capacitance vs Target Distance (40 to 60 mm)

8.2 Typical Application

The FDC can be used to measure liquid level in non-conductive containers. Due to its very high excitation rate capability, it is able to measure soapy water, ink, soap, and other conductive liquids. Capacitive sensors can be attached to the outside of the container or be located remotely from the container, allowing for contactless measurements.

The working principle is based on a ratiometric measurement; Figure 60 shows a possible system implementation which uses three electrodes. The level electrode provides a capacitance value proportional to the liquid level. The reference environmental electrode and the reference liquid electrode are used as references. The reference liquid electrode accounts for the liquid dielectric constant and its variation, while the reference environmental electrode is used to compensate for any other environmental variations that are not due to the liquid itself. Note that the reference environmental electrode and the reference liquid electrode are the same physical size (hREF).

For this application, single-ended measurements on the active channels are appropriate, as the tank is grounded. Use to determine the liquid level from the measured capacitances:

Typical Application (continued)

$$Level = h_{ref} \frac{C_{Lev} - C_{Lev}(0)}{C_{RL} - C_{RE}}$$

where

- C_{RE} is the capacitance of the reference environmental electrode,
- C_{RL} is the capacitance of the reference liquid electrode,
- C_{Lev} is the current value of the capacitance measured at the level electrode sensor,
- $C_{Lev}(0)$ is the capacitance of the Level electrode when the container is empty, and
- h_{REF} is the height in the desired units of the container or liquid reference electrodes.

The ratio between the capacitance of the level and the reference electrodes allows simple calculation of the liquid level inside the container itself. Very high sensitivity values (that is, many LSB/mm) can be obtained due to the high resolution of the FDC2x1x, even when the sensors are located remotely from the container. Note that this approach assumes that the container has a uniform cross section from top to bottom, so that each incremental increase or decrease in the liquid represents a change in volume that is directly related to the height of the liquid.

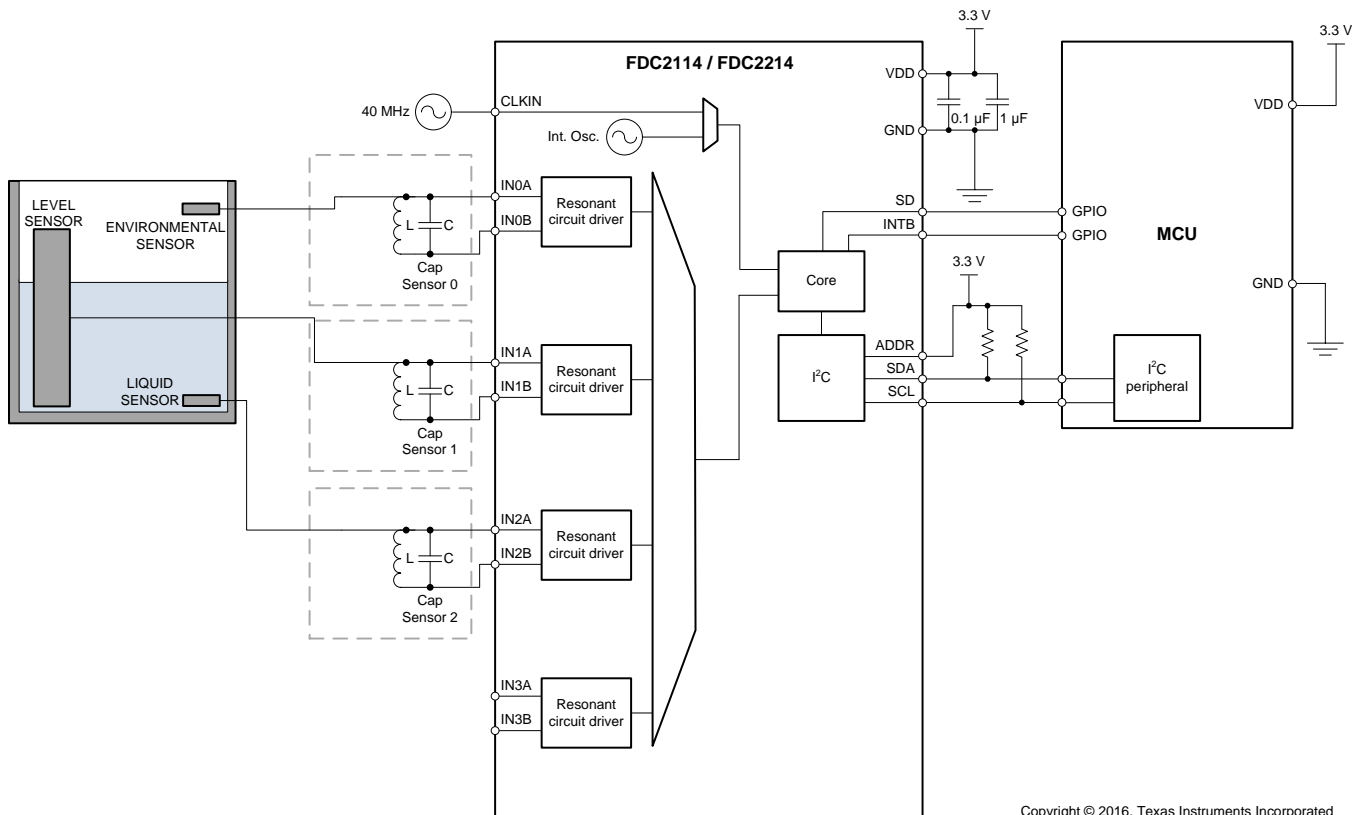

Figure 60. FDC (Liquid Level Measurement)

8.2.1 Design Requirements

The liquid level measurement should be independent of the liquid, which can be achieved using the 3-electrode design described above. Moreover, the sensor should be isolated from environmental interferers such as a human body, other objects, or EMI.

8.2.2 Detailed Design Procedure

In capacitive sensing systems, the design of the sensor plays an important role in determining system performance and capabilities. In most cases the sensor is simply a metal plate that can be designed on the PCB.

Typical Application (continued)

The sensor used in this example is implemented with a two-layer PCB. On the top layer, which faces the tank, there are the 3 electrodes (reference environmental, reference liquid, and level) with a ground plane surrounding the electrodes.

Depending on the shape of the container, the FDC can be located on the sensor PCB to minimize the length of the traces between the input channels and the sensors. In case the shape of the container or other mechanical constraints do not allow having the sensors and the FDC on the same PCB, the traces which connect the channels to the sensor need to be shielded with the appropriate shield.

8.2.3 Application Performance Plot

A liquid level sensor with 3 electrodes like the one shown in the schematic was connected to the EVM. The plot shows the capacitance measured by Level sensor at different levels of liquid in the tank. The capacitance of the Reference Liquid and Reference Environmental sensors have a steady value because they experience consistent exposure to liquid and air, while the capacitance of the level sensor (Level) increases linearly with the height of the liquid in the tank.

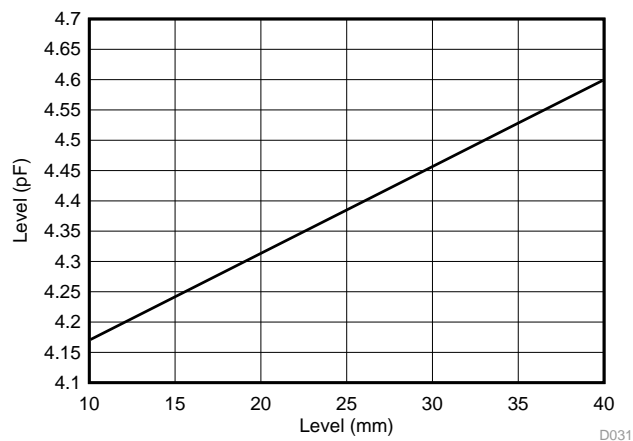

Figure 61. Electrodes' Capacitance vs Liquid Level

8.2.4 Recommended Initial Register Configuration Values

The application requires 100SPS ($T_{SAMPLE} = 10$ ms). A sensor with an 18- μ H inductor and a 33-pF capacitor is used. Additional pin, trace, and wire capacitance accounts for 20 pF, so the total capacitance is 53-pF.

Using L and C, $f_{SENSOR} = 1/2\pi\sqrt{LC} = 1/2\pi\sqrt{(18 \times 10^{-6} \times 50 \times 10^{-12})} = 5.15$ MHz. This represents the maximum sensor frequency. When the sensor capacitance is added, the frequency will decrease.

Using a system master clock of 40 MHz applied to the CLKIN pin allows flexibility for setting the internal clock frequencies. The sensor coils are connected to channel 0 (IN0A and IN0B pins), channel 1 (IN1A and IN1B pins), and channel 2 (IN2A and IN2B pins).

After powering on the FDC, it will be in Sleep Mode. Program the registers as follows (example sets registers for channel 0 only; channel 1 and channel 2 registers can use equivalent configuration):

- Set the dividers for channel 0.
 - Because the sensor is in a single-ended configuration, the sensor frequency select register should be set to 2, which means setting field CH0_FIN_SEL to b10.
 - The design constraint for f_{REF0} is $> 4 \times f_{SENSOR}$. To satisfy this constraint, f_{REF0} must be greater than 20.6 MHz, so the reference divider should be set to 1. This is done by setting the CH0_FREQ_DIVIDER field to 0x01.
 - The combined value for Chan. 0 divider register (0x14) is 0x2001.
- Sensor drive current: to ensure that the oscillation amplitude is between 1.2V and 1.8V, measure the oscillation amplitude on an oscilloscope and adjust the IDRIVE value, or use the integrated FDC GUI feature to determine the optimal setting. In this case the IDRIVE value should be set to 15 (decimal), which results in an oscillation amplitude of 1.68 V(pk). The INIT_DRIVE current field should be set to 0x00. The combined value for the DRIVE_CURRENT_CH0 register (addr 0x1E) is 0x7C00.

Typical Application (continued)

3. Program the settling time for Channel 0 (see [Multi-Channel and Single-Channel Operation](#)).
 - (a) $CHx_SETTLECOUNT > V_{pk} \times f_{REFx} \times C \times \pi^2 / (32 \times IDRIVE_x) \rightarrow 7.5$, rounded up to 8. To provide margin to account for system tolerances, a higher value of 10 is chosen.
 - (b) Register 0x10 should be programmed to a minimum of 10.
 - (c) The settle time is: $(10 \times 16)/40,000,000 = 4 \mu s$
 - (d) The value for Channel 0 SETTLECOUNT register (0x10) is 0x000A.
4. The channel switching delay is approximately 1 μs for $f_{REF} = 40$ MHz (see [Multi-Channel and Single-Channel Operation](#))
5. Set the conversion time by the programming the reference count for Channel 0. The budget for the conversion time is : $1/N \times (T_{SAMPLE} - \text{settling time} - \text{channel switching delay}) = 1/3 (10,000 - 4 - 1) = 3.33$ ms
 - (a) To determine the conversion time register value, use the following equation and solve for CH0_RCOUNT: Conversion Time (t_{C0})= $(CH0_RCOUNT \times 16)/f_{REF0}$.
 - (b) This results in CH0_RCOUNT having a value of 8329 decimal (rounded down). Note that this yields an ENOB > 13 bits.
 - (c) Set the CH0_RCOUNT register (0x08) to 0x2089.
6. Use the default values for the ERROR_CONFIG register (address 0x19). By default, no interrupts are enabled
7. Program the MUX_CONFIG register
 - (a) Set the AUTOSCAN_EN to b1 bit to enable sequential mode
 - (b) Set RR_SEQUENCE to b10 to enable data conversion on three channels (channel 0, channel 1, channel 2)
 - (c) Set DEGLITCH to b101 to set the input deglitch filter bandwidth to 10 MHz, the lowest setting that exceeds the oscillation tank frequency.
 - (d) The combined value for the MUX_CONFIG register (address 0x1B) is 0xC20D
8. Finally, program the CONFIG register as follows:
 - (a) Set the ACTIVE_CHAN field to b00 to select channel 0.
 - (b) Set SLEEP_MODE_EN field to b0 to enable conversion.
 - (c) Set SENSOR_ACTIVATE_SEL = b0, for full current drive during sensor activation
 - (d) Set the REF_CLK_SRC field to b1 to use the external clock source.
 - (e) Set the other fields to their default values.
 - (f) The combined value for the CONFIG register (address 0x1A) is 0x1601.

We then read the conversion results for channel 0 to channel 2 every 10ms from register addresses 0x00 to 0x05.

Based on the example configuration above, TI recommends the following register write sequence is recommended:

Table 47. Recommended Initial Register Configuration Values (Multi-channel Operation)

ADDRESS	VALUE	REGISTER NAME	COMMENTS
0x08	0x8329	RCOUNT_CH0	Reference count calculated from timing requirements (100 SPS) and resolution requirements
0x09	0x8329	RCOUNT_CH1	Reference count calculated from timing requirements (100 SPS) and resolution requirements
0x0A	0x8329	RCOUNT_CH2	Reference count calculated from timing requirements (100 SPS) and resolution requirements
0x10	0x000A	SETTLECOUNT_CH0	Minimum settling time for chosen sensor
0x11	0x000A	SETTLECOUNT_CH1	Minimum settling time for chosen sensor
0x12	0x000A	SETTLECOUNT_CH2	Minimum settling time for chosen sensor
0x14	0x2002	CLOCK_DIVIDER_CH0	CH0_FIN_DIVIDER = 1, CH0_FREF_DIVIDER = 2
0x15	0x2002	CLOCK_DIVIDER_CH1	CH1_FIN_DIVIDER = 1, CH1_FREF_DIVIDER = 2
0x16	0x2002	CLOCK_DIVIDER_CH2	CH1_FIN_DIVIDER = 1, CH1_FREF_DIVIDER = 2
0x19	0x0000	ERROR_CONFIG	Can be changed from default to report status and error conditions

Typical Application (continued)

Table 47. Recommended Initial Register Configuration Values (Multi-channel Operation) (continued)

ADDRESS	VALUE	REGISTER NAME	COMMENTS
0x1B	0xC20D	MUX_CONFIG	Enable Ch 0 , Ch 1, and Ch 2 (sequential mode), set Input deglitch bandwidth to 10MHz
0x1E	0x7C00	DRIVE_CURRENT_CH0	Sets sensor drive current on ch 0
0x1F	0x7C00	DRIVE_CURRENT_CH1	Sets sensor drive current on ch 1
0x20	0x7C00	DRIVE_CURRENT_CH2	Sets sensor drive current on ch 2
0x1A	0x1601	CONFIG	Enable full current drive during sensor activation, select external clock source, wake up device to start conversion. This register write must occur last because device configuration is not permitted while the FDC is in active mode.

8.3 Do's and Don'ts

- Do leave a small gap between sensor plates in differential configurations. 2-3mm minimum separation is recommended.
- The FDC does not support hot-swapping of the sensors. Do not hot-swap sensors, for example by using external multiplexers.

9 Power Supply Recommendations

The FDC requires a voltage supply within 2.7 V and 3.6 V. TI recommends multilayer ceramic bypass X7R capacitors of 0.1 μF and 1 μF between the VDD and GND pins. If the supply is located more than a few inches from the FDC, additional bulk capacitance may be required in addition to the ceramic bypass capacitors. An electrolytic capacitor with a value of 10 μF is a typical choice.

The optimum placement is closest to the VDD and GND pins of the device. Care should be taken to minimize the loop area formed by the bypass capacitor connection, the VDD pin, and the GND pin of the device. See [Figure 62](#) and [Figure 65](#) for layout examples.

10 Layout

10.1 Layout Guidelines

- Avoid long traces to connect the sensor to the FDC. Short traces reduce parasitic capacitances between sensor inductor and offer higher system performance.
- Systems that require matched channel response need to have matched trace length on all active channels.

10.2 Layout Examples

[Figure 62](#) to [Figure 65](#) show the FDC2114 / FDC2214 evaluation module (EVM) layout.

Layout Examples (continued)

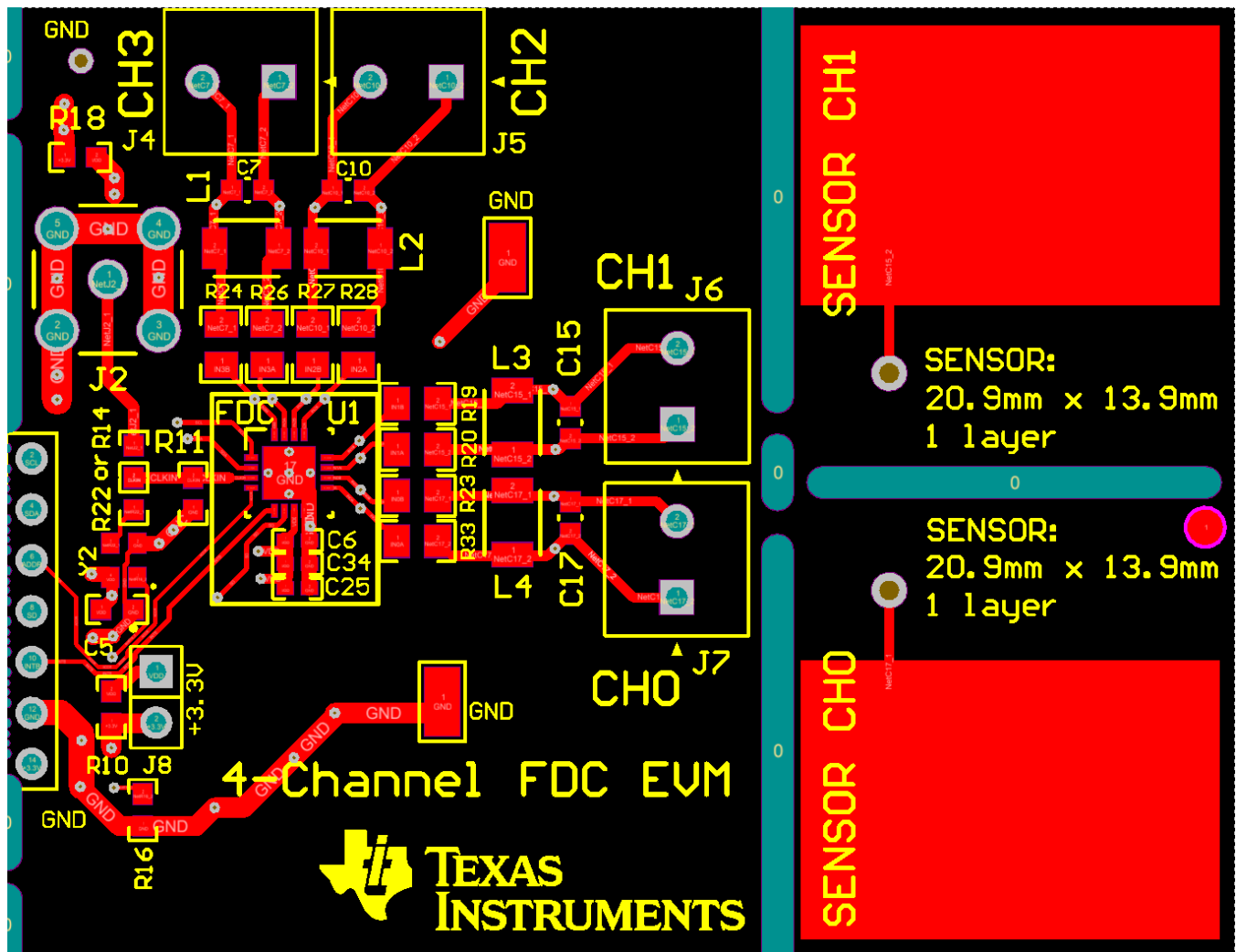

Figure 62. Example PCB Layout: Top Layer (Signal)

Layout Examples (continued)

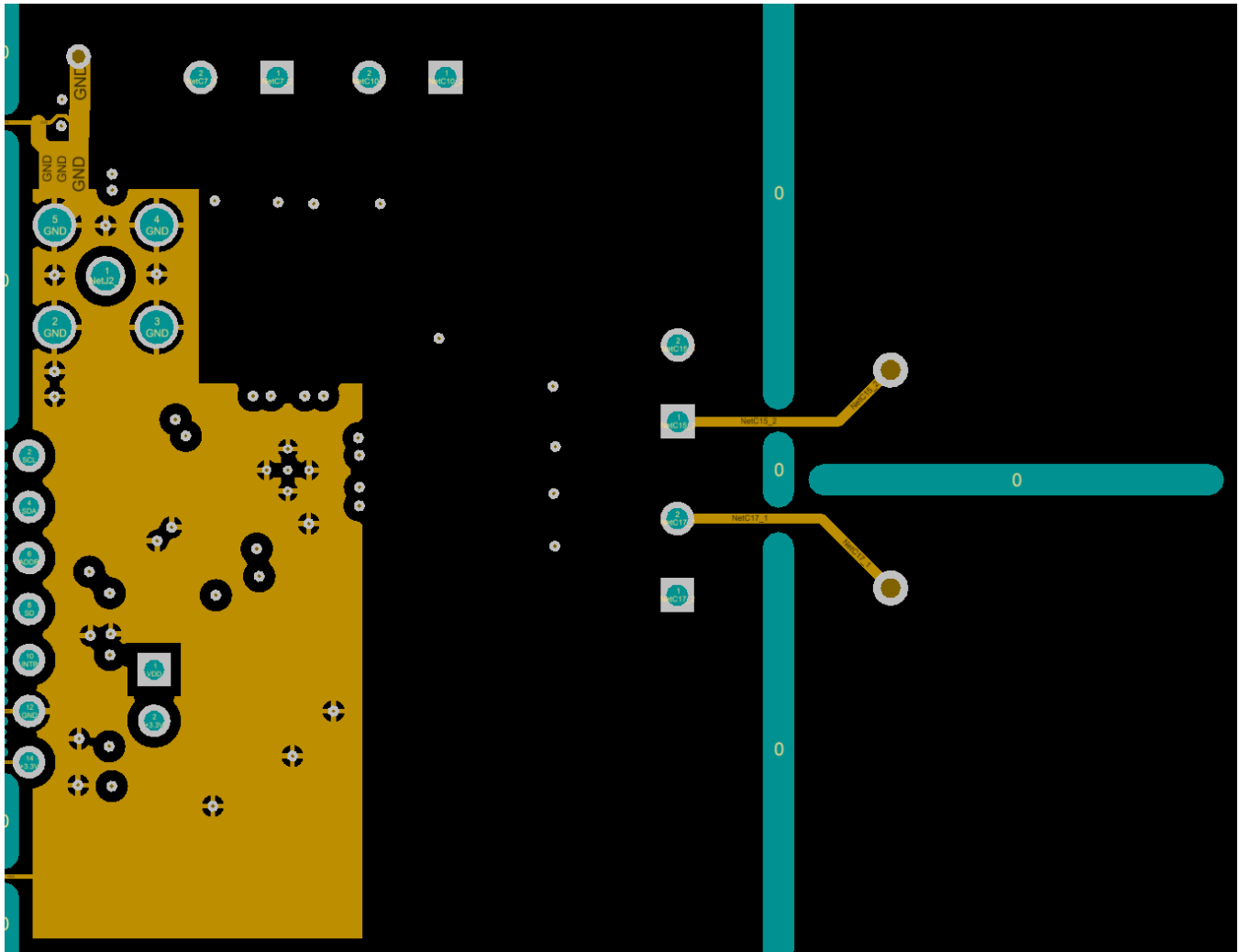

Figure 63. Example PCB Layout: Mid-Layer 1 (GND)

Layout Examples (continued)

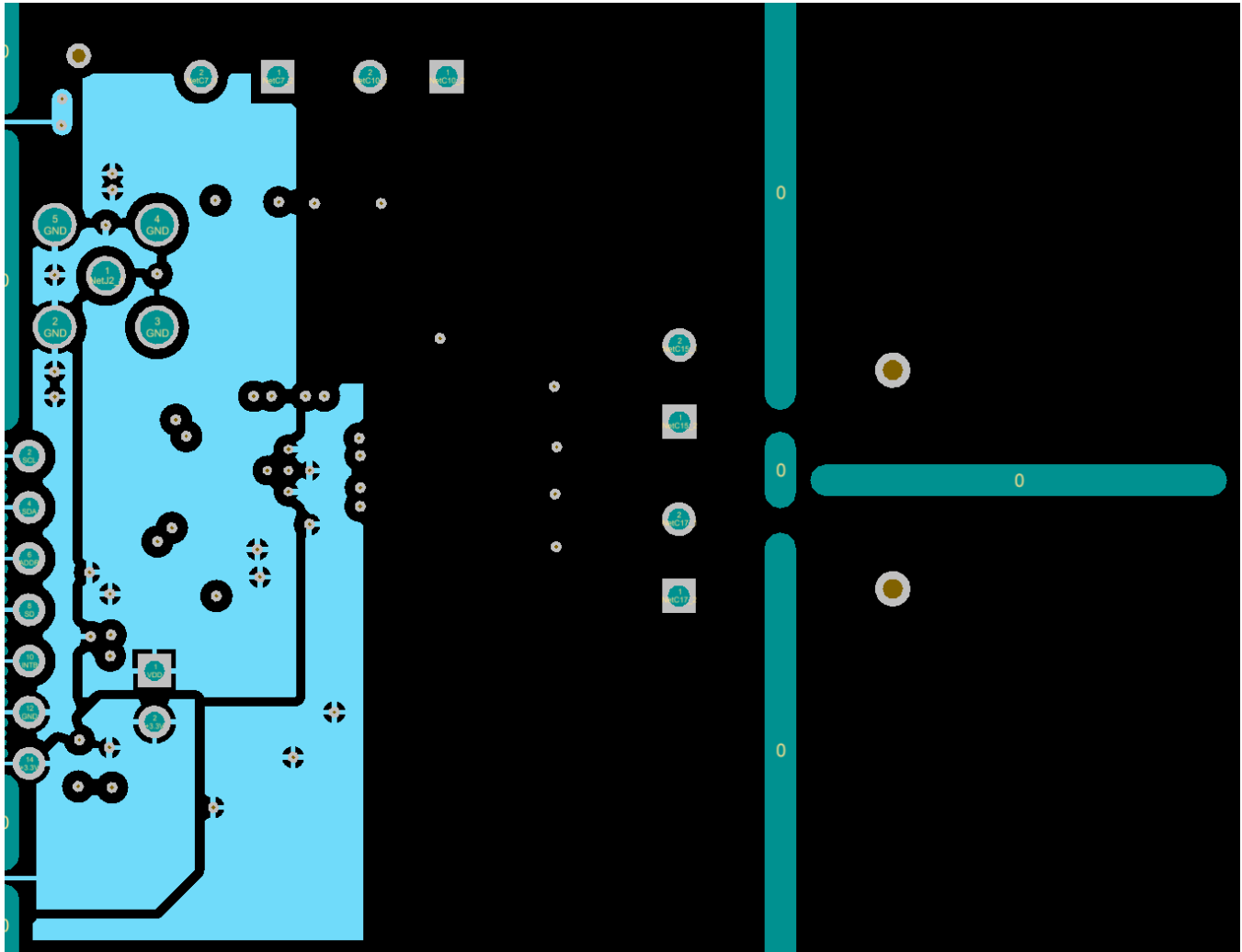

Figure 64. Example PCB Layout: Mid-layer 2 (Power)

Layout Examples (continued)

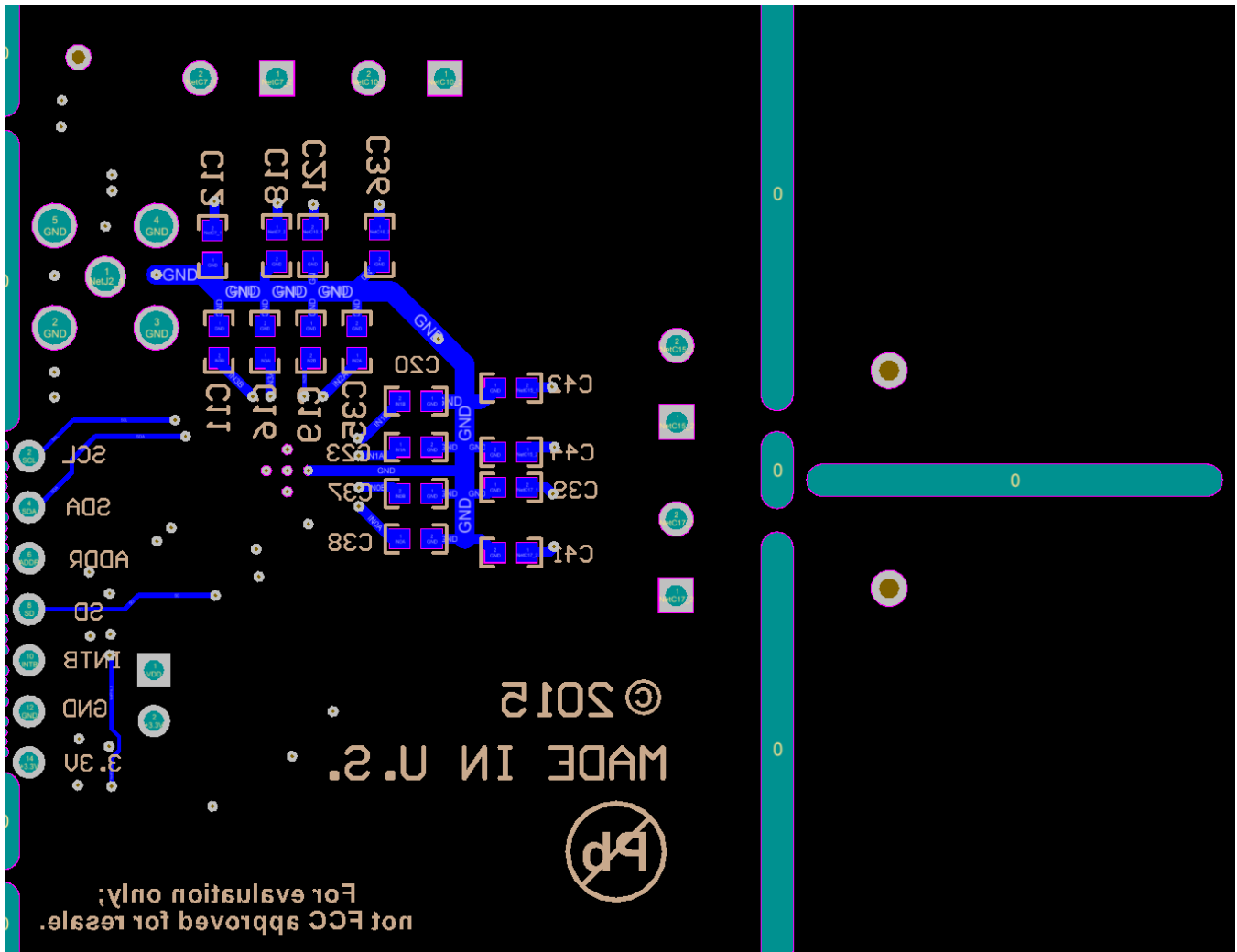

Figure 65. Example PCB Layout: Bottom Layer (Signal)

11 器件和文档支持

11.1 器件支持

11.1.1 开发支持

相关链接如下：

德州仪器 (TI) 的 WEBENCH®工具：<http://www.ti.com.cn/webench>

11.2 文档支持

11.2.1 相关文档

相关文档如下：

有关传统和新热指标的更多信息，请参见应用报告《半导体和 IC 封装热指标》（文献编号：SPRA953）

11.3 社区资源

The following links connect to TI community resources. Linked contents are provided "AS IS" by the respective contributors. They do not constitute TI specifications and do not necessarily reflect TI's views; see TI's [Terms of Use](#).

TI E2E™ Online Community *TI's Engineer-to-Engineer (E2E) Community*. Created to foster collaboration among engineers. At e2e.ti.com, you can ask questions, share knowledge, explore ideas and help solve problems with fellow engineers.

Design Support *TI's Design Support* Quickly find helpful E2E forums along with design support tools and contact information for technical support.

11.4 相关链接

下面的表格列出了快速访问链接。范围包括技术文档、支持与社区资源、工具和软件，并且可以快速访问样片或购买链接。

表 48. 相关链接

器件	产品文件夹	样片与购买	技术文档	工具与软件	支持与社区
FDC2112-Q1	请单击此处	请单击此处	请单击此处	请单击此处	请单击此处
FDC2114-Q1	请单击此处	请单击此处	请单击此处	请单击此处	请单击此处
FDC2212-Q1	请单击此处	请单击此处	请单击此处	请单击此处	请单击此处
FDC2214-Q1	请单击此处	请单击此处	请单击此处	请单击此处	请单击此处

11.5 商标

E2E is a trademark of Texas Instruments.

WEBENCH is a registered trademark of Texas Instruments.

All other trademarks are the property of their respective owners.

11.6 静电放电警告



这些装置包含有限的内置 ESD 保护。存储或装卸时，应将导线一起截短或将装置放置于导电泡棉中，以防止 MOS 门极遭受静电损伤。

11.7 Glossary

[SLYZ022](#) — *TI Glossary*.

This glossary lists and explains terms, acronyms, and definitions.

12 机械、封装和可订购信息

以下页中包括机械、封装和可订购信息。这些信息是针对指定器件可提供的最新数据。这些数据会在无通知且不对本文档进行修订的情况下发生改变。欲获得该数据表的浏览器版本，请查阅左侧的导航栏。

PACKAGING INFORMATION

Orderable Device	Status (1)	Package Type	Package Drawing	Pins	Package Qty	Eco Plan (2)	Lead finish/ Ball material (6)	MSL Peak Temp (3)	Op Temp (°C)	Device Marking (4/5)	Samples
FDC2112QDNTRQ1	ACTIVE	WSON	DNT	12	4500	RoHS & Green	SN	Level-3-260C-168 HR	-40 to 125	FDC2112 Q1	Samples
FDC2112QDNTTQ1	ACTIVE	WSON	DNT	12	250	RoHS & Green	SN	Level-3-260C-168 HR	-40 to 125	FDC2112 Q1	Samples
FDC2114QRGHRQ1	ACTIVE	WQFN	RGH	16	4500	RoHS & Green	SN	Level-3-260C-168 HR	-40 to 125	FC2114Q	Samples
FDC2114QRGHTQ1	ACTIVE	WQFN	RGH	16	250	RoHS & Green	SN	Level-3-260C-168 HR	-40 to 125	FC2114Q	Samples
FDC2212QDNTRQ1	ACTIVE	WSON	DNT	12	4500	RoHS & Green	SN	Level-3-260C-168 HR	-40 to 125	FDC2212 Q1	Samples
FDC2212QDNTTQ1	ACTIVE	WSON	DNT	12	250	RoHS & Green	SN	Level-3-260C-168 HR	-40 to 125	FDC2212 Q1	Samples
FDC2214QRGHRQ1	ACTIVE	WQFN	RGH	16	4500	RoHS & Green	SN	Level-3-260C-168 HR	-40 to 125	FC2214Q	Samples
FDC2214QRGHTQ1	ACTIVE	WQFN	RGH	16	250	RoHS & Green	SN	Level-3-260C-168 HR	-40 to 125	FC2214Q	Samples

(1) The marketing status values are defined as follows:

ACTIVE: Product device recommended for new designs.

LIFEBUY: TI has announced that the device will be discontinued, and a lifetime-buy period is in effect.

NRND: Not recommended for new designs. Device is in production to support existing customers, but TI does not recommend using this part in a new design.

PREVIEW: Device has been announced but is not in production. Samples may or may not be available.

OBSELETE: TI has discontinued the production of the device.

(2) **RoHS:** TI defines "RoHS" to mean semiconductor products that are compliant with the current EU RoHS requirements for all 10 RoHS substances, including the requirement that RoHS substance do not exceed 0.1% by weight in homogeneous materials. Where designed to be soldered at high temperatures, "RoHS" products are suitable for use in specified lead-free processes. TI may reference these types of products as "Pb-Free".

RoHS Exempt: TI defines "RoHS Exempt" to mean products that contain lead but are compliant with EU RoHS pursuant to a specific EU RoHS exemption.

Green: TI defines "Green" to mean the content of Chlorine (Cl) and Bromine (Br) based flame retardants meet JS709B low halogen requirements of <=1000ppm threshold. Antimony trioxide based flame retardants must also meet the <=1000ppm threshold requirement.

(3) MSL, Peak Temp. - The Moisture Sensitivity Level rating according to the JEDEC industry standard classifications, and peak solder temperature.

(4) There may be additional marking, which relates to the logo, the lot trace code information, or the environmental category on the device.

⁽⁵⁾ Multiple Device Markings will be inside parentheses. Only one Device Marking contained in parentheses and separated by a "-" will appear on a device. If a line is indented then it is a continuation of the previous line and the two combined represent the entire Device Marking for that device.

⁽⁶⁾ Lead finish/Ball material - Orderable Devices may have multiple material finish options. Finish options are separated by a vertical ruled line. Lead finish/Ball material values may wrap to two lines if the finish value exceeds the maximum column width.

Important Information and Disclaimer:The information provided on this page represents TI's knowledge and belief as of the date that it is provided. TI bases its knowledge and belief on information provided by third parties, and makes no representation or warranty as to the accuracy of such information. Efforts are underway to better integrate information from third parties. TI has taken and continues to take reasonable steps to provide representative and accurate information but may not have conducted destructive testing or chemical analysis on incoming materials and chemicals. TI and TI suppliers consider certain information to be proprietary, and thus CAS numbers and other limited information may not be available for release.

In no event shall TI's liability arising out of such information exceed the total purchase price of the TI part(s) at issue in this document sold by TI to Customer on an annual basis.

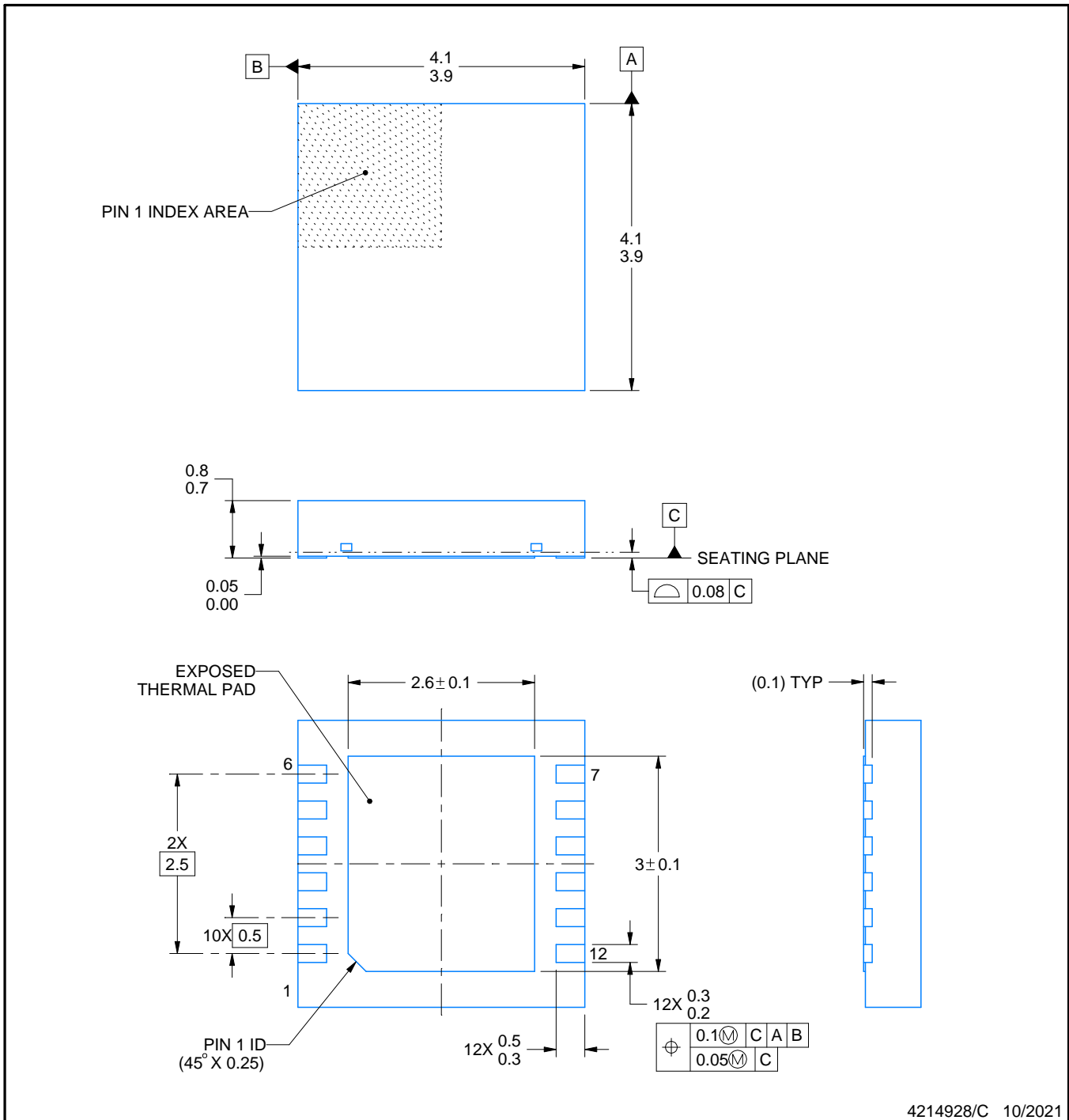
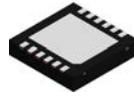

4214928/C 10/2021

NOTES:

1. All linear dimensions are in millimeters. Any dimensions in parenthesis are for reference only. Dimensioning and tolerancing per ASME Y14.5M.
2. This drawing is subject to change without notice.
3. The package thermal pad must be soldered to the printed circuit board for thermal and mechanical performance.

EXAMPLE BOARD LAYOUT

DNT0012B

WSON - 0.8 mm max height

PLASTIC SMALL OUTLINE - NO LEAD

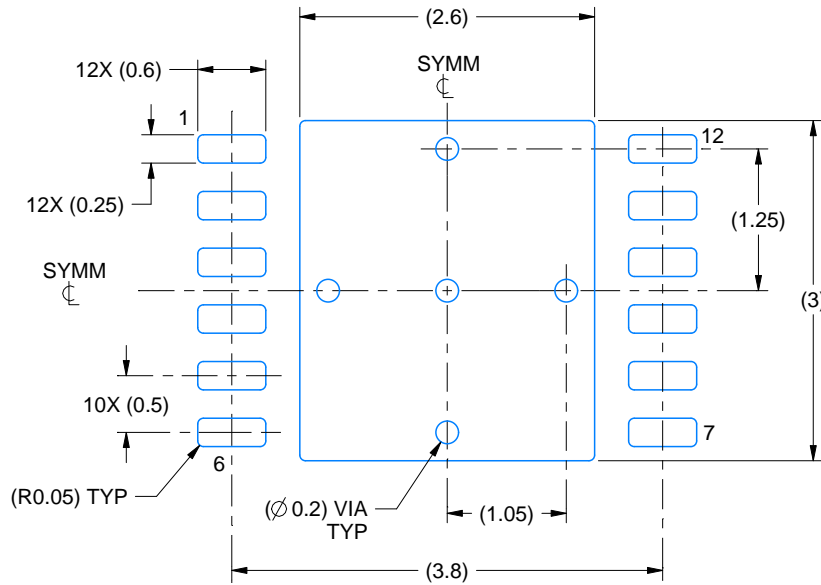

LAND PATTERN EXAMPLE
EXPOSED METAL SHOWN
SCALE:15X

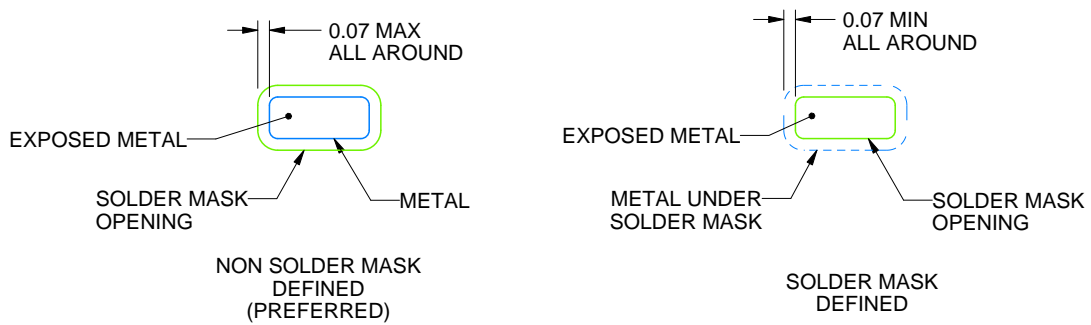

SOLDER MASK DETAILS

4214928/C 10/2021

NOTES: (continued)

4. This package is designed to be soldered to a thermal pad on the board. For more information, see Texas Instruments literature number SLUA271 (www.ti.com/lit/slua271).

EXAMPLE STENCIL DESIGN

DNT0012B

WSON - 0.8 mm max height

PLASTIC SMALL OUTLINE - NO LEAD

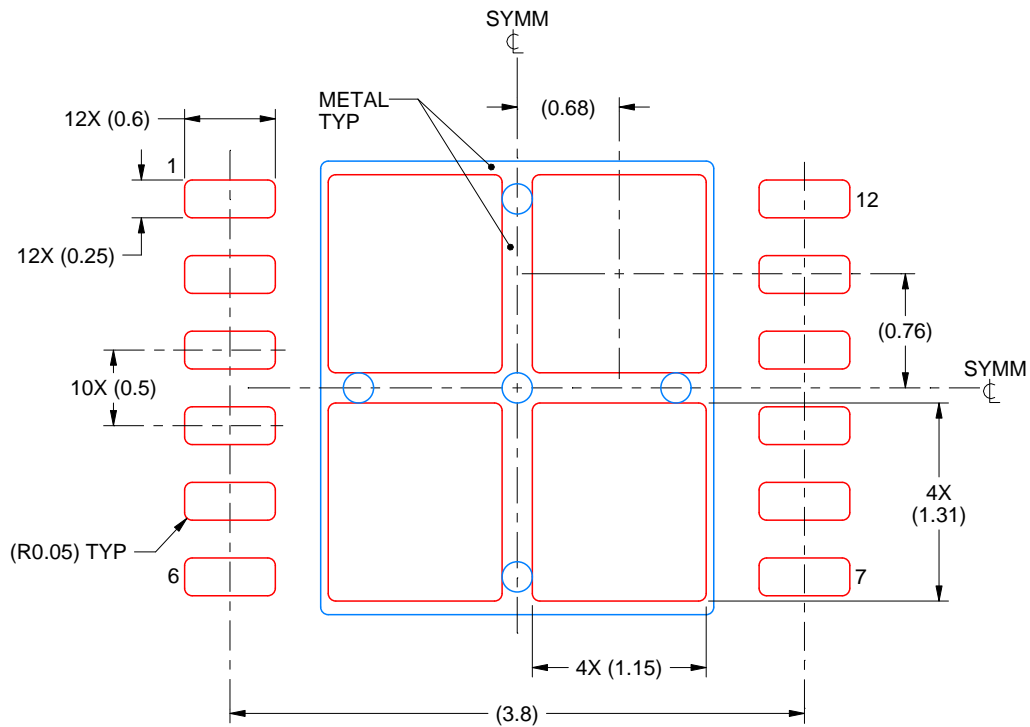

SOLDER PASTE EXAMPLE
BASED ON 0.125 mm THICK STENCIL

EXPOSED PAD
77% PRINTED SOLDER COVERAGE BY AREA
SCALE:20X

4214928/C 10/2021

NOTES: (continued)

5. Laser cutting apertures with trapezoidal walls and rounded corners may offer better paste release. IPC-7525 may have alternate design recommendations.

RGH (S-PQFP-N16)

PLASTIC QUAD FLATPACK

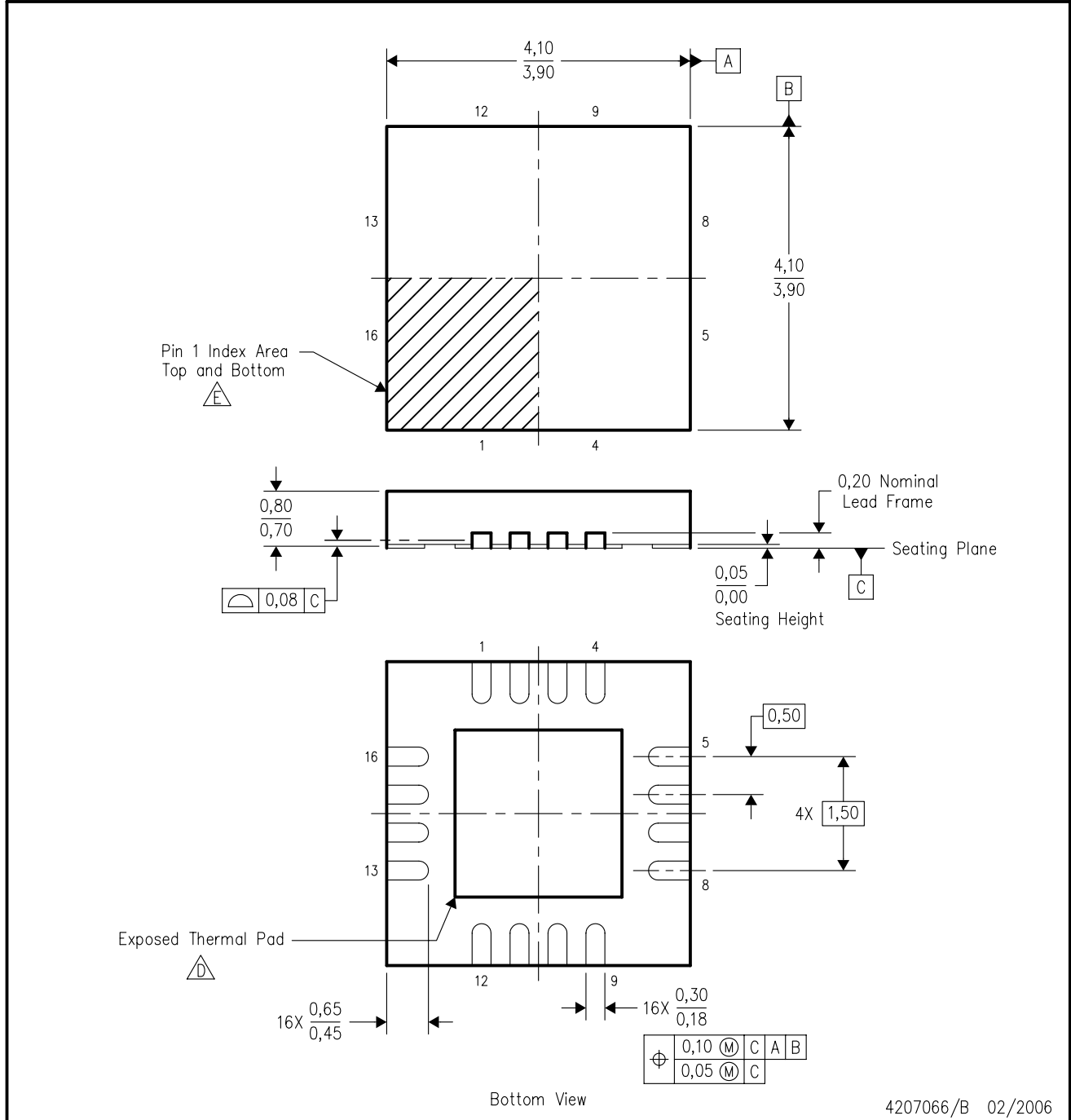

4207066/B 02/2006

- NOTES:
- A. All linear dimensions are in millimeters. Dimensioning and tolerancing per ASME Y14.5M-1994.
 - B. This drawing is subject to change without notice.
 - C. QFN (Quad Flatpack No-Lead) package configuration.
 - The package thermal pad must be soldered to the board for thermal and mechanical performance. See the Product Data Sheet for details regarding the exposed thermal pad dimensions.
 - Pin 1 identifiers are located on both top and bottom of the package and within the zone indicated. The Pin 1 identifiers are either a molded, marked, or metal feature.
 - F. Complies to JEDEC MO-220 variation WGGD-4.

重要声明和免责声明

TI“按原样”提供技术和可靠性数据（包括数据表）、设计资源（包括参考设计）、应用或其他设计建议、网络工具、安全信息和其他资源，不保证没有瑕疵且不做任何明示或暗示的担保，包括但不限于对适销性、某特定用途方面的适用性或不侵犯任何第三方知识产权的暗示担保。

这些资源可供使用 TI 产品进行设计的熟练开发人员使用。您将自行承担以下全部责任：(1) 针对您的应用选择合适的 TI 产品，(2) 设计、验证并测试您的应用，(3) 确保您的应用满足相应标准以及任何其他功能安全、信息安全、监管或其他要求。

这些资源如有变更，恕不另行通知。TI 授权您仅可将这些资源用于研发本资源所述的 TI 产品的应用。严禁对这些资源进行其他复制或展示。您无权使用任何其他 TI 知识产权或任何第三方知识产权。您应全额赔偿因在这些资源的使用中对 TI 及其代表造成的任何索赔、损害、成本、损失和债务，TI 对此概不负责。

TI 提供的产品受 [TI 的销售条款](#) 或 [ti.com](#) 上其他适用条款/TI 产品随附的其他适用条款的约束。TI 提供这些资源并不会扩展或以其他方式更改 TI 针对 TI 产品发布的适用的担保或担保免责声明。

TI 反对并拒绝您可能提出的任何其他或不同的条款。

邮寄地址：Texas Instruments, Post Office Box 655303, Dallas, Texas 75265

Copyright © 2022，德州仪器 (TI) 公司